

PACK LIVO/BAZIL

60cm / 80cm

823552
823556
823054
823554



LED 6W

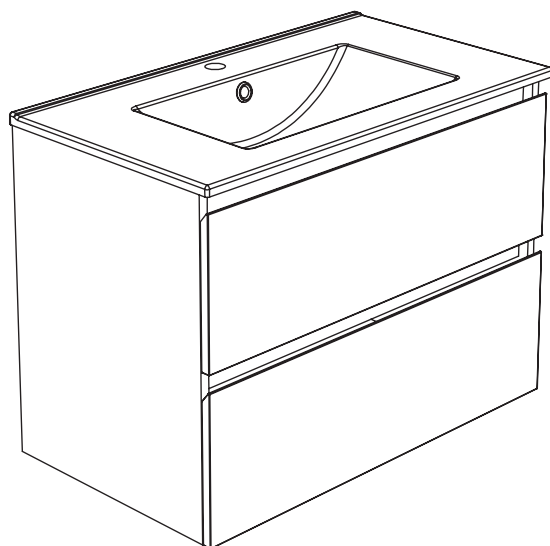
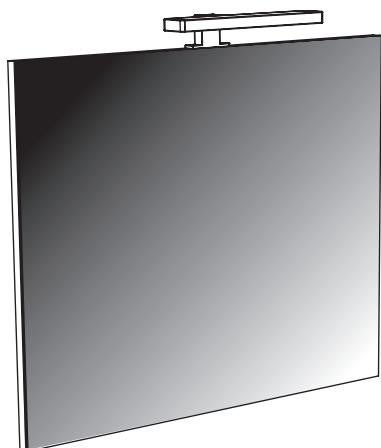
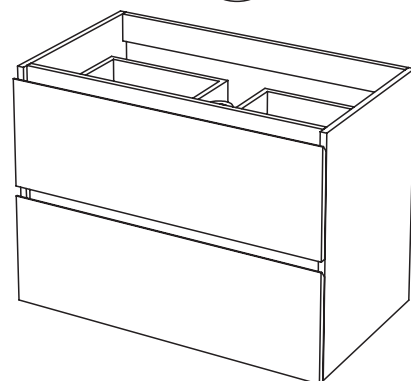
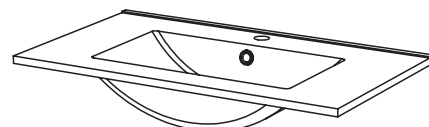

F : Outillages conseillés (non fournis)
NL : Aanbevolen gereedschap (niet bijgeleverd)
GB : Useful tools / parts (not supplied)
DE : Empfohlenes Werkzeug (nicht im Lieferumfang enthalten)

<p>F : Mitigeur lavabo (non fournis) NL : Lavabomengkraan (niet bijgeleverd) GB : Faucet (not supplied) DE : Mischer Waschbecken (nicht mitgeliefert)</p>		

Consignes de sécurité et d'entretien

- Ce meuble ne doit pas être installé directement contre la zone de bain/douche. Une paroi de protection doit être installée.
- La salle de bain doit être correctement ventilée (fenêtre, VMC, ...)
- En cas d'éclaboussures abondantes, nettoyer et sécher immédiatement
- Pour un usage durable et sans altération, il est recommandé de ne nettoyer le meuble qu'au moyen d'un chiffon propre doux et légèrement imbibé d'eau savonneuse, ou d'une éponge douce.
- Ne jamais employer de poudre à récurer, d'agents abrasifs, de produits anti-calcaire, ni de solvants pour nettoyer le meuble.
- Limites de la garantie : l'usage de produits de nettoyage tels que les nettoyeurs pour vitres, les produits chimiques pour les toilettes, les agents anti-calcaires, les poudres à récurer, ou tout autre produit agressif peut endommager ce meuble, et entraîne la perte de la garantie du fabricant.
- Entretien du plan vasque : utiliser une crème liquide sans abrasif et de l'eau chaude pour nettoyer le lavabo.
- Ne jamais utiliser de poudre à récurer.
- Pour préserver la brillance du plan vasque, utiliser de temps à autre un produit lustre pour carrosserie automobile. Appliquer le polish et nettoyer immédiatement.
- La température de l'eau du robinet ne doit pas dépasser 65°C.

Veiligheid- en onderhoudinstructies:

- Dit meubel mag niet rechtstreeks tegen een wand van een bad of douche worden geïnstalleerd. Een beschermingswand moet worden geïnstalleerd.
- Het is ook belangrijk dat de badkamer behoorlijk wordt geventileerd (middels venster, ventilator, ...)
- In het geval van waterspatten, onmiddellijk reinigen en drogen.
- Voor een duurzaam en langdurig gebruik, wordt aanbevolen om het meubel te reinigen met een zachte doek of spons met zeepwater. Gebruik nooit schuurpoeder, schurende poetsmiddelen of soortgelijke agressieve producten.
- Beperkingen op de garantie zijn:
Het gebruik van glasreiniger, chemische stoffen voor wc, anti-kalk reinigingsmiddelen, schuurpoeder of andere agressieve producten die schade aan het meubel kunnen toebrengen. Leiden tot ontheffing of verlies van de garantie door de fabrikant.
- Onderhoud van de wastafel: gebruik van vloeibare crème of zeep zonder schurende bestanddelen met warm water. Gebruik nooit schuurpoeder of dergelijke poetsmiddelen. Voor behoud van de glans van de wastafel kan u polijstglansmiddel voor autocarrosserie gebruiken. Aanbrengen en direct reinigen. De temperatuur van het water in de kraan mag niet hoger zijn dan 65 °C

Cleaning / maintenance :

- Installation : Furniture unit must be installed away from bathing / showering area. If located closely, a shower partition must be installed.
- Ensure sufficient ventilation in the bathroom (windows, venting).
- In case of water splashes, remove water immediately and wipe.
- Maintenance : For gentle cleaning of bathroom furniture units, we recommend to use only a damp cloth or soapy water and a sponge. Never use abrasive and scouring agent or solvents.
- Care instructions for mineral washbasin : Use a mild liquid cleaning agent and warm water to clean your washbasin. Never use scouring powder! Normal car polish can be used from time to time to preserve the shine of the washbasin surface (apply and polish off immediately). Please ensure that water temperature does not exceed 65°C.
- Limits of te warranty : The use of cleaning agents such as glass cleaners, chemicals, toilet detergents, scouring powders, anti-cal agents, or any other aggressive products might damage the furniture unit and thus cancels the manufacturer's guarantee.

Sicherheits- und Wartungshinweise:

- Diesen Schrank nicht direkt an die Wand einer Badewanne oder Dusche installieren. Eine Schutzwand muss zuerst dazwischen installiert sein.
- Es ist wichtig, das Bad ausreichend zu belüften (Fenster, Lüfter, ...)
- Spritzwasser sofort säubern und trocknen.
- Für eine nachhaltige und langfristige Nutzung, empfehlen wir den Schrank mit einem weichem Tuch oder Schwamm mit einer Seifenlauge zu reinigen. Niemals Scheuermittel oder andere aggressive Produkte gebrauchen.
- Garantie Einschränkungen: Der Gebrauch von Glasreiniger, Toilettenchemikalien, Anti-Kalk Reinigern, Scheuerpulver oder andere aggressive Produkte, welche den Möbeln Schaden zufügen können führen automatisch zum Verlust der Garantie.
- Wartung des Beckens: Reinigung mit flüssiger Creme oder Seife ohne abriebfeste Teile und warmem Wasser. Verwenden Sie niemals Scheuerpulver oder ähnliche Politur. Um das Becken glänzend zu halten empfehlen wir Ihnen Autolackpolitur zu gebrauchen. Nach Anwendung unmittelbar reinigen.
- Die Temperatur des Wassers im Wasserhahn darf nicht höher sein als 65°C.

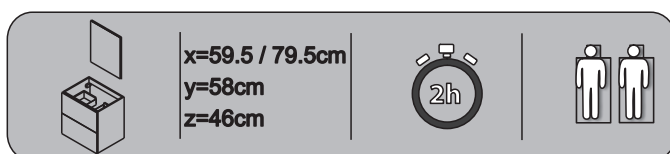

Garantie

Le fabricant garantit ce meuble pour une période de 2 ans à compter de la date d'achat.
La garantie couvre les défauts de fabrication constatés lors d'un usage normal de ce produit, sont exclues les parties soumises à une usure normale telles que les lampes par exemple.
Ce meuble doit être installé dans les règles de l'art.
Les vis et chevilles de fixation sont prévues pour des murs pleins, et présentent une résistance à la charge suffisante.
Employer d'autres fixations spéciales si les murs sont de nature différente.
Les dimensions mentionnées dans cette notice sont en mm.
Les parties électriques doivent être installées par un électricien professionnel suivant la norme NF C 15-100.

Garantie:

Garantie voor een termijn van 2 jaar door de fabrikant vanaf de aankoopdatum.
De garantie dekt fabricagefouten bij een normaal gebruik.
Uitgezonderd de onderdelen die onderhevig zijn aan normale slijtage zoals de lampen.
Dit meubel dient geïnstalleerd te worden volgens de regels van de kunst m.n. vakmanschap.
De bijgeleverde schroeven en pluggen zijn voorzien voor montage tegen volle muren en kunnen het totale geleverde gewicht van het meubel dragen.
Gebruik andere schroeven en pluggen indien de muren van andere aard zijn.
De vermelde afmetingen in deze montage-instructie zijn uitgedrukt in mm.
De elektrische aansluitingen dienen te worden uitgevoerd door een professionele vakman volgens de norm NF C 15-100.

Garanttee:

The manufacturer guarantees this furniture unit for a period of 2 years from date of purchase.
The guarantee covers any product failure which may occur due to manufacturing fault.
However it excludes any part subject to normal wear (such as bulbs,...)
The cupboards should only be installed by experts.
The fixing material (screws, wall plugs) is suitable for solid walls with sufficient load-bearing capacity.
Please use special fitting in other situations.
All above dimensions are in mm.
Electrical fitting should only be installed by experts in view of part 701 of DIN57100/VDE0100.

Garantie:

Garantie des Herstellers für einen Zeitraum von 2 Jahren ab Kaufdatum.
Die Garantie deckt Fabrikationsfehler bei normalem Gebrauch.
Mit Ausnahme der Teile, die einem normalen Verschleiß unterliegen wie z.B. Lampen.
Dieser Schrank ist nach den Regeln der Handwerkskunst zu installieren.









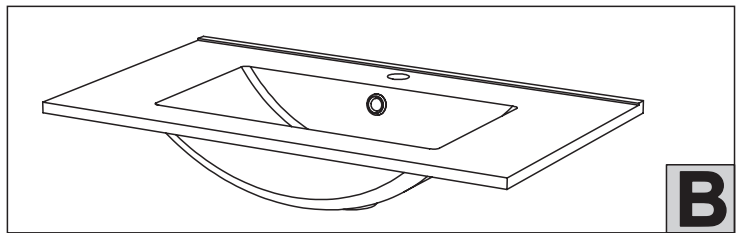
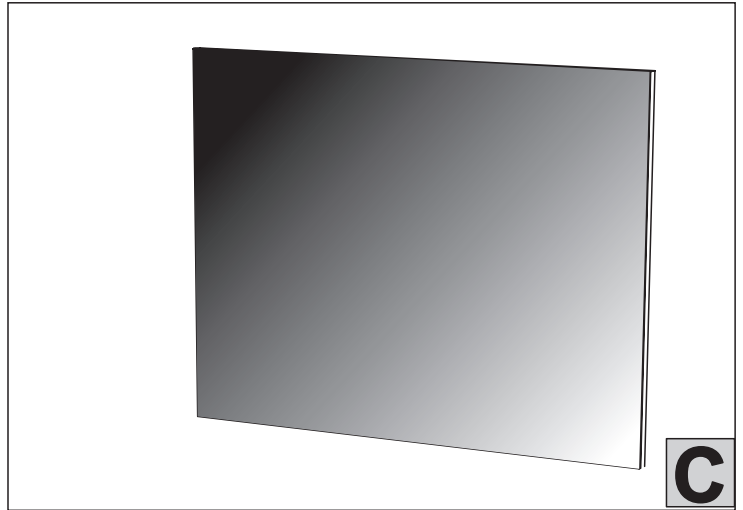
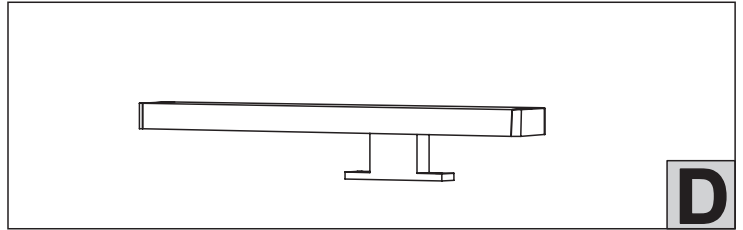
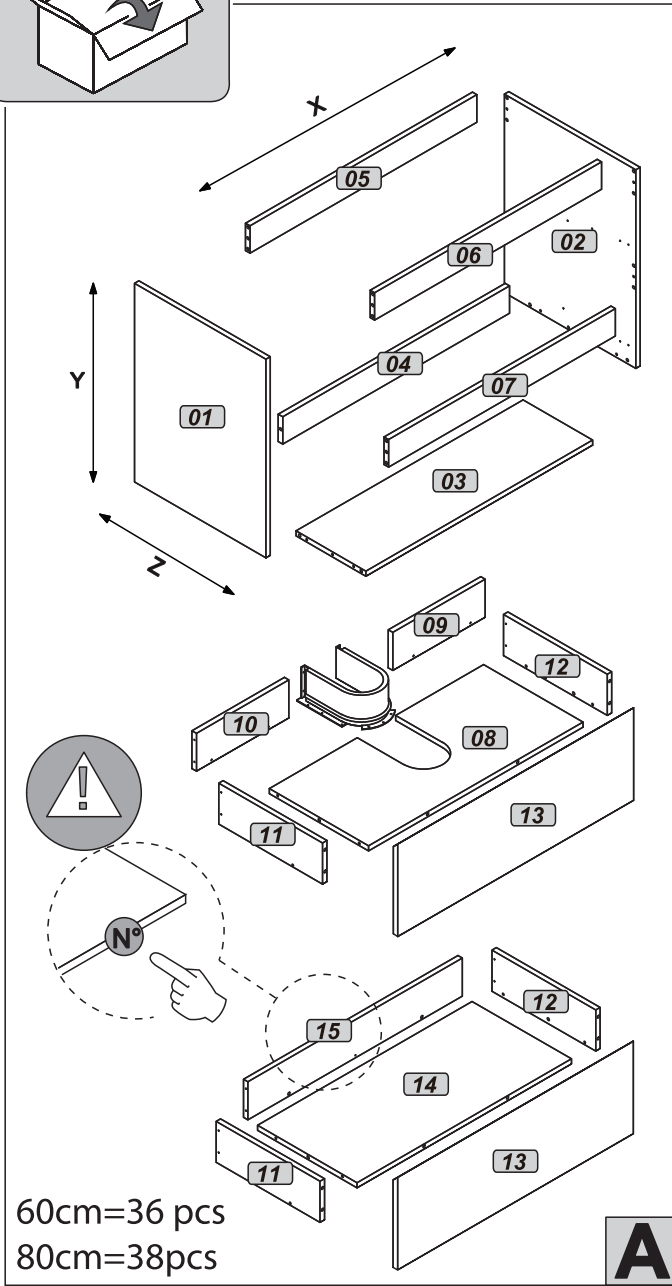
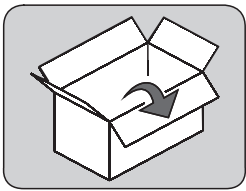

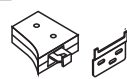

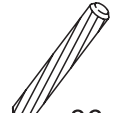

Die mitgelieferten Schrauben und Dübel sind geeignet um den Schrank an massive Wände zu befestigen, und dessen Eigengewicht zu tragen.
Verwenden Sie andere Schrauben und Dübel, wenn Sie den Schrank nicht an massive Wände befestigen möchten.

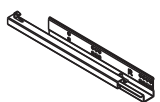
Die Abmessungen in der Montageanleitung sind in mm wiedergegeben.

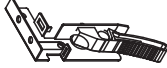
Die elektrischen Anschlüsse müssen von einem Fachmann durchgeführt werden nach Norm NF C 15-100.



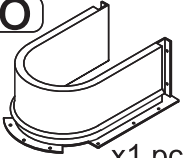

<p>A</p>  <p>x36 pcs</p>	<p>B</p>  <p>x2 pcs</p>	<p>C</p>  <p>x36 pcs</p>	<p>D</p>  <p>x36 pcs</p>	<p>E</p> <p>ST4*16mm</p>  <p>x17 pcs</p>	<p>F</p> <p>ST2*15mm</p>  <p>x2 pcs</p>
<p>G</p> <p>ST4*30mm</p>  <p>x4 pcs</p>	<p>H</p>  <p>x2 pcs</p>	<p>I</p>  <p>x2 pcs</p>	<p>J</p> <p>Ø8x40mm</p>  <p>x6 pcs</p>	<p>K</p>  <p>Lx2 pcs Rlx2 pcs x4 pcs</p>	<p>L</p> <p>ST5*40mm</p>  <p>x7 pcs</p>
<p>M</p>  <p>x16 pcs</p>	<p>N</p>  <p>x6 pcs</p>	<p>O</p>  <p>x1 pcs</p>	<p>P</p>  <p>x8 pcs</p>		<p>E</p>

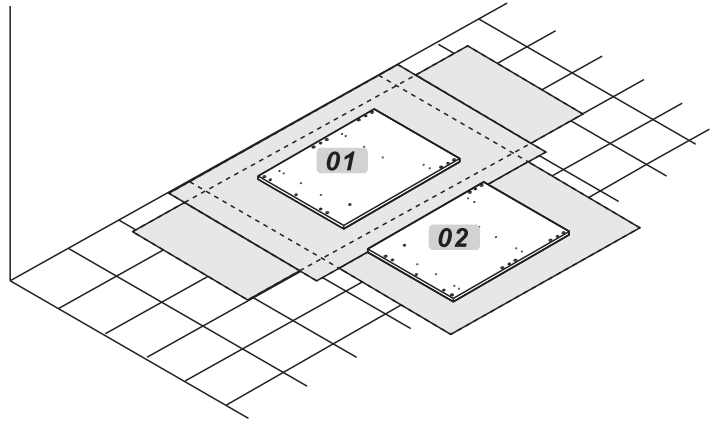
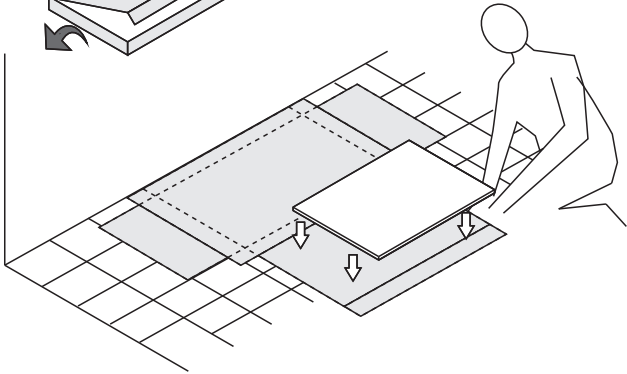
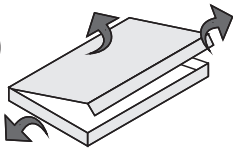

1

Etape
Step
Stage
Schritt



x14 pcs



x2 pcs



x4 pcs

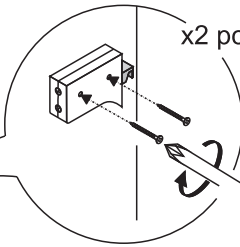
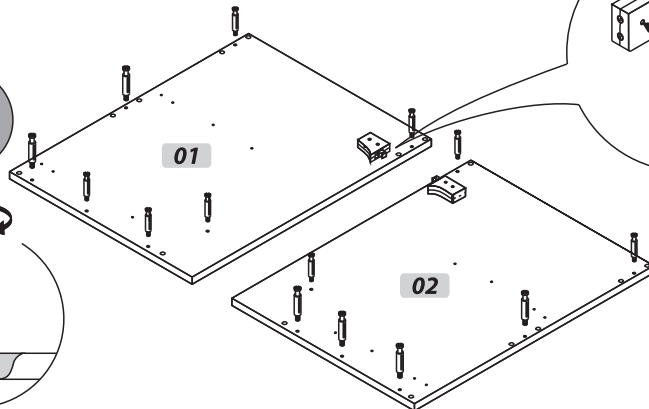
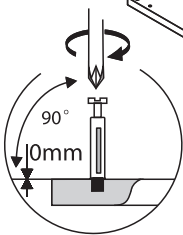

2

Etape
Step
Stage
Schritt



x7 pcs



x20 pcs



x5 pcs

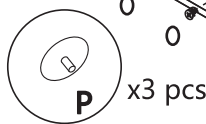
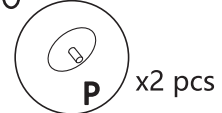
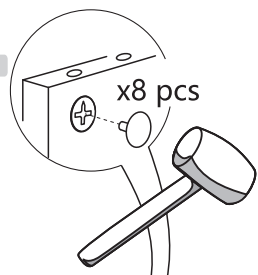
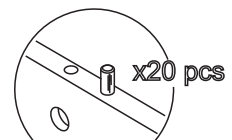
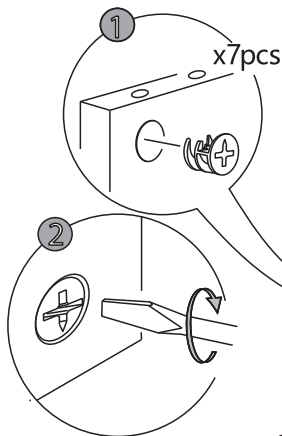

3

Etape
Step
Stage
Schritt

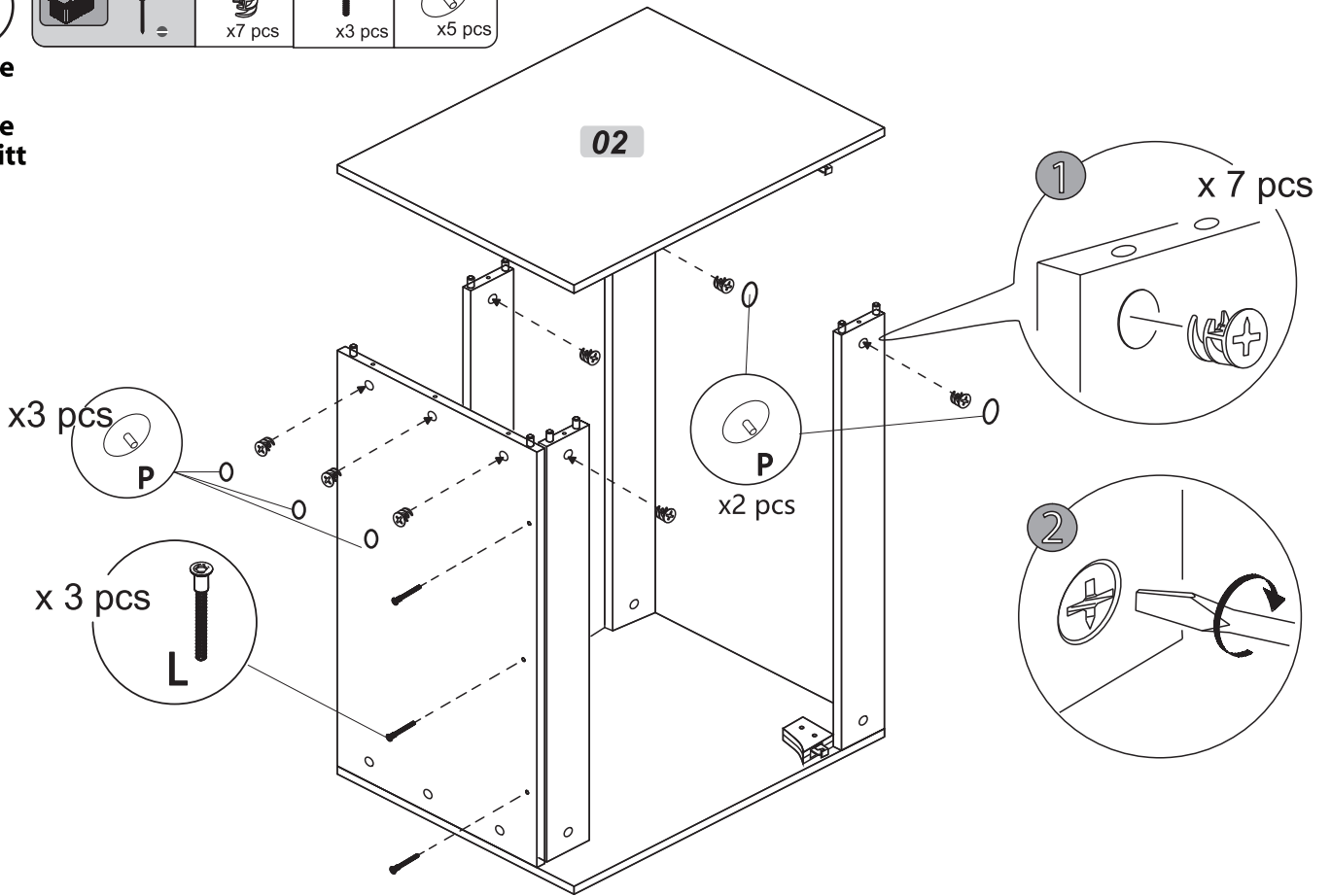

4

Etape
Step
Stage
Schritt

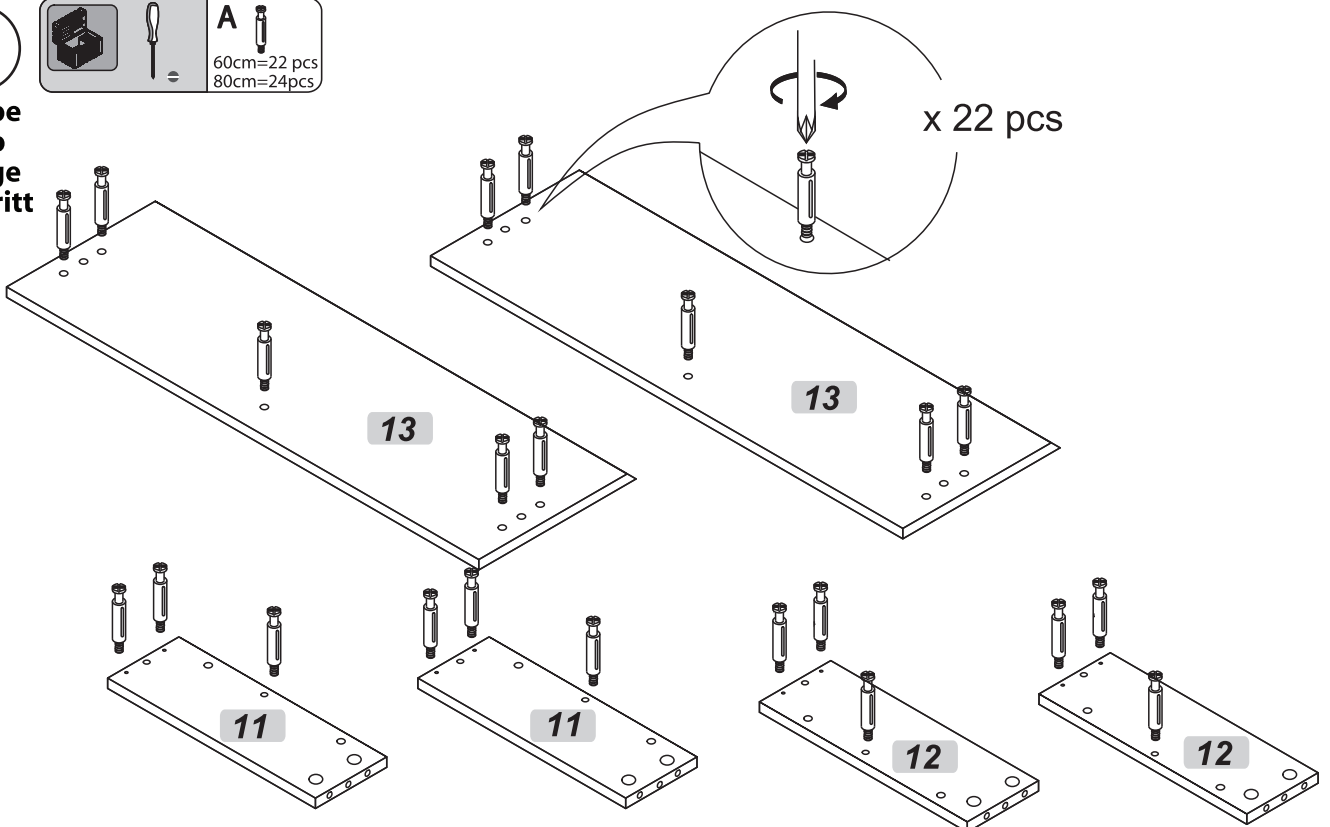
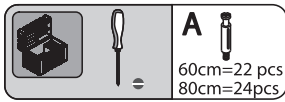

5

Etape
Step
Stage
Schritt

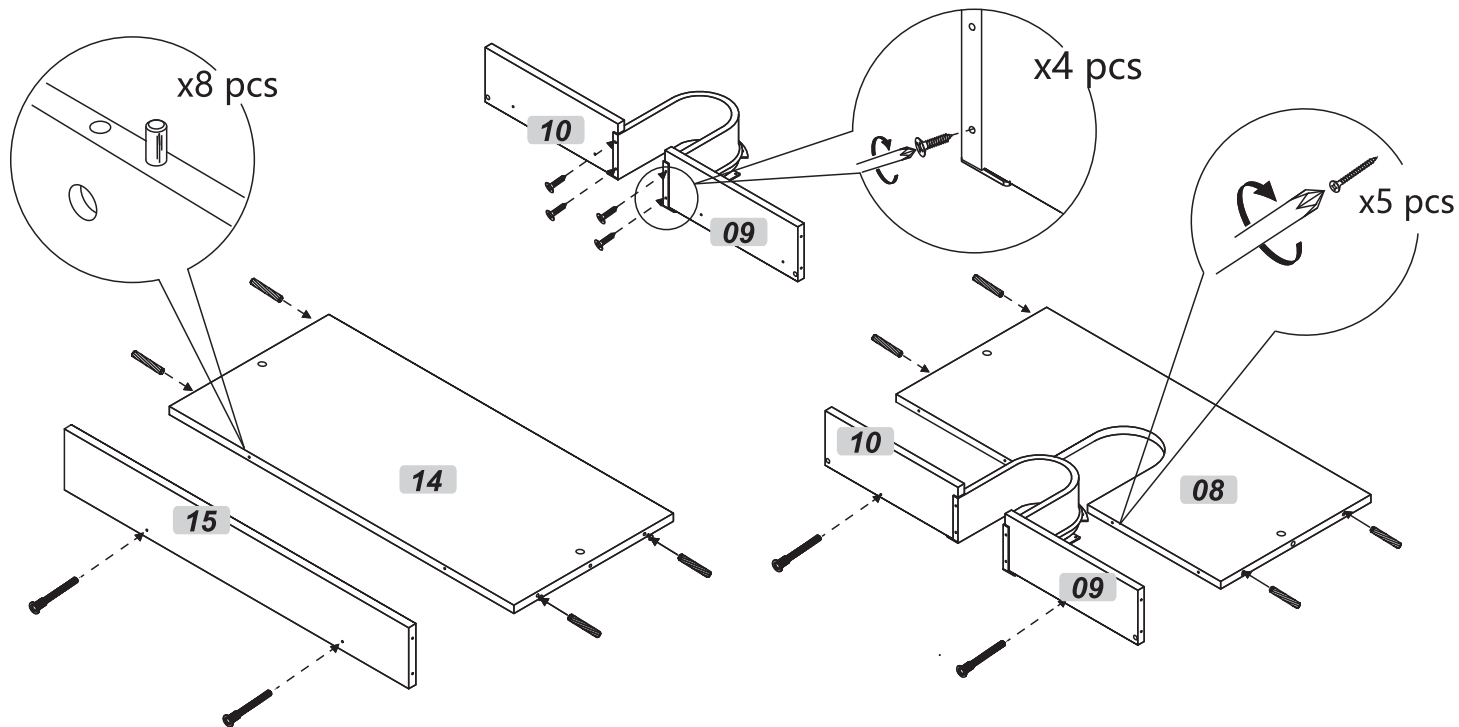

6

Etape
Step
Stage
Schritt

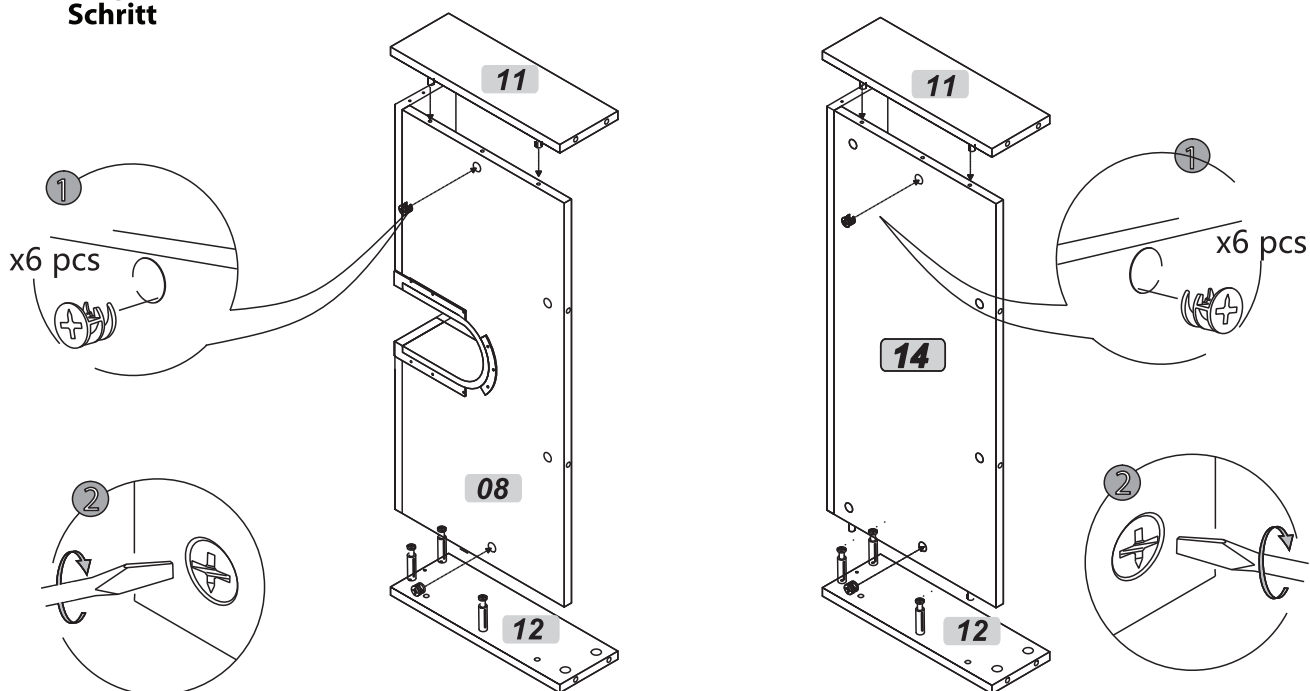
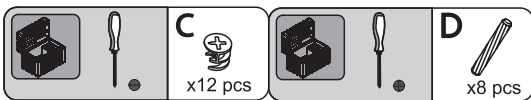

7

Etape
Step
Stage
Schritt

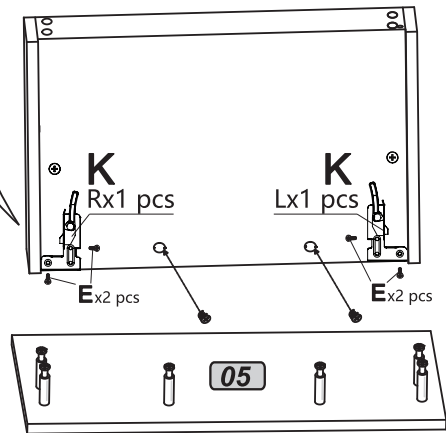
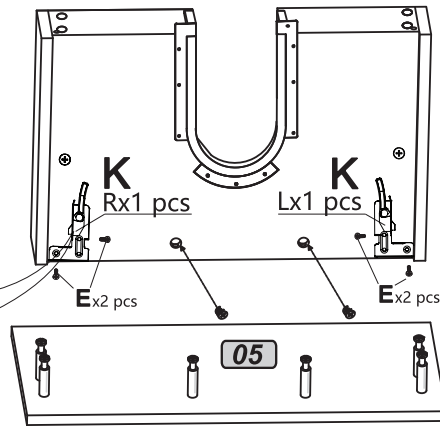
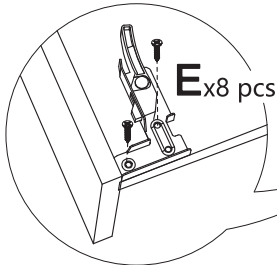
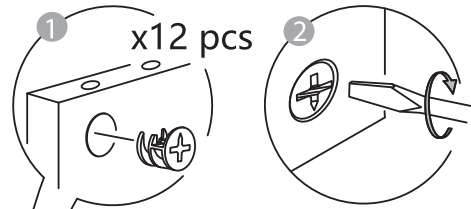
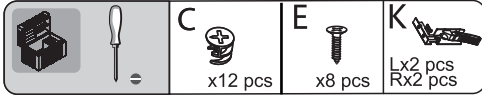

8

Etape
Step
Stage
Schritt

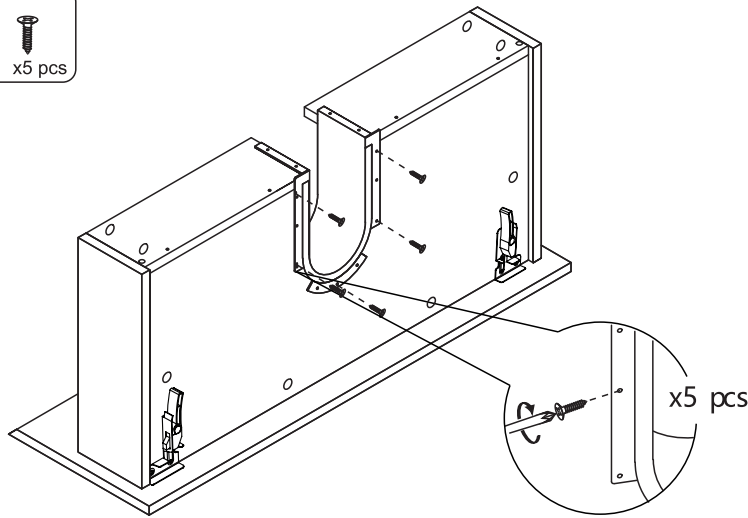
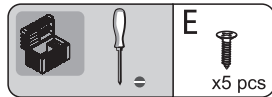

9

Etape
Step
Stage
Schritt

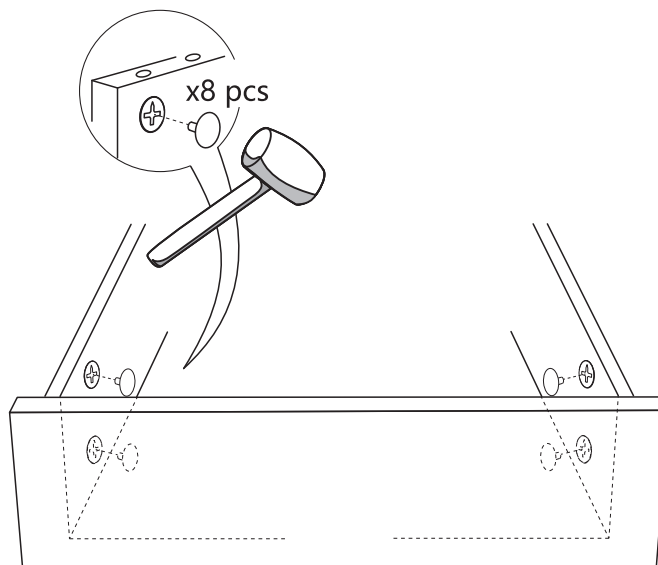
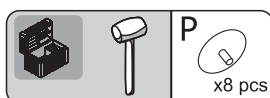

10

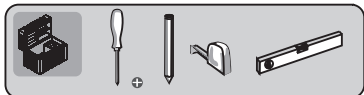

11

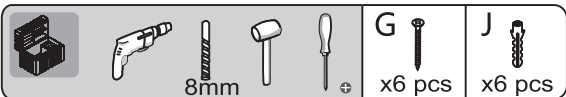

Etape
Step
Stage
Schritt

60cm = 460mm
80cm = 660mm

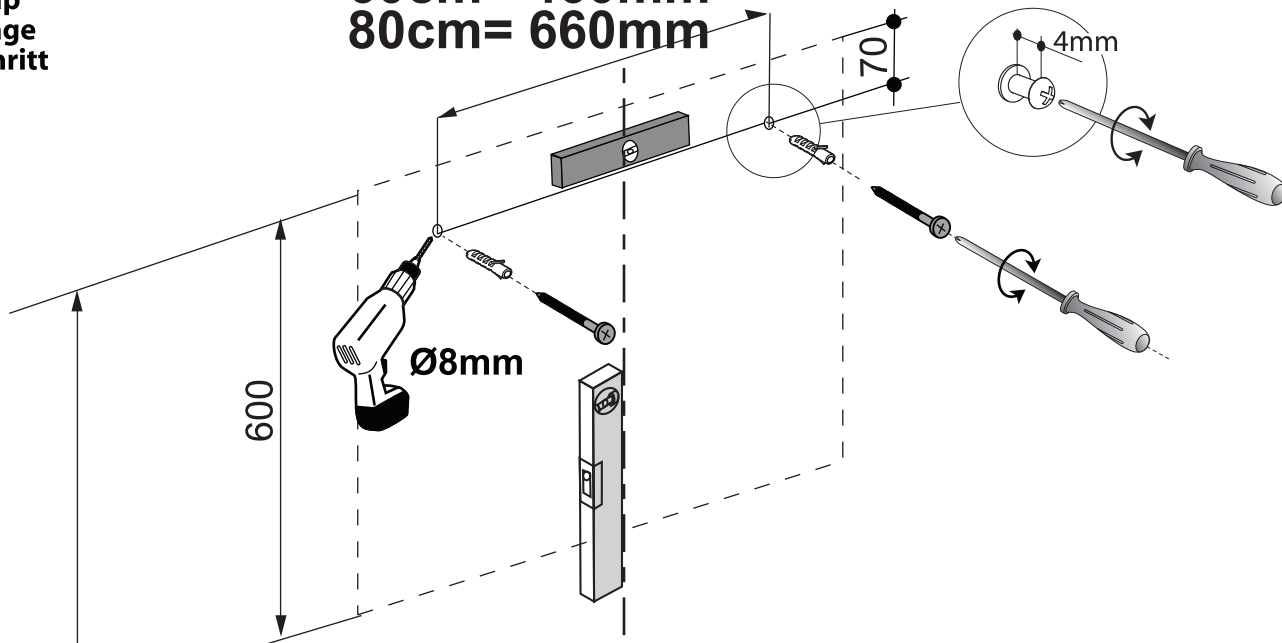

60cm = 538mm
80cm = 738mm

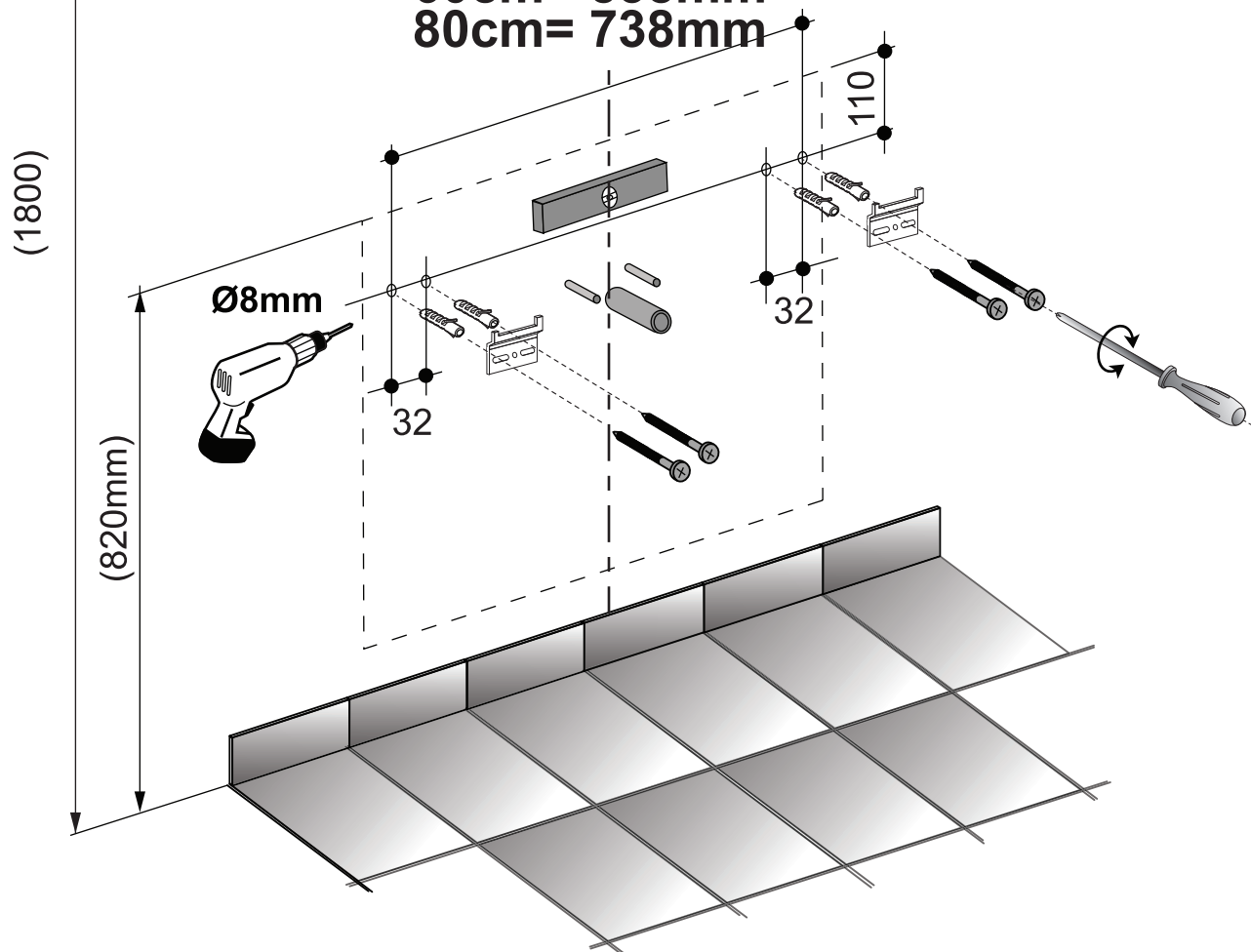

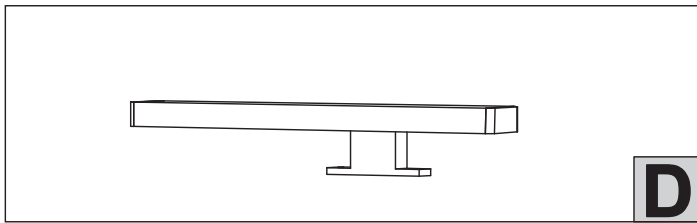

D

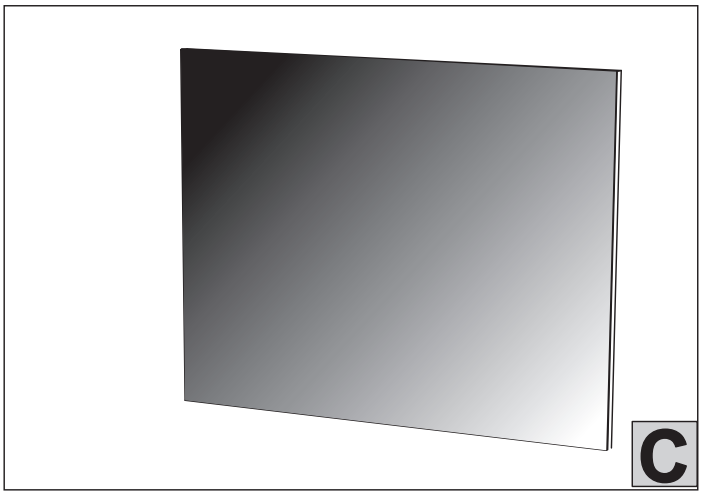

C

CE

IP44

230V~50Hz

LED 6W

Volumes d'installation suivant NF C 15-100

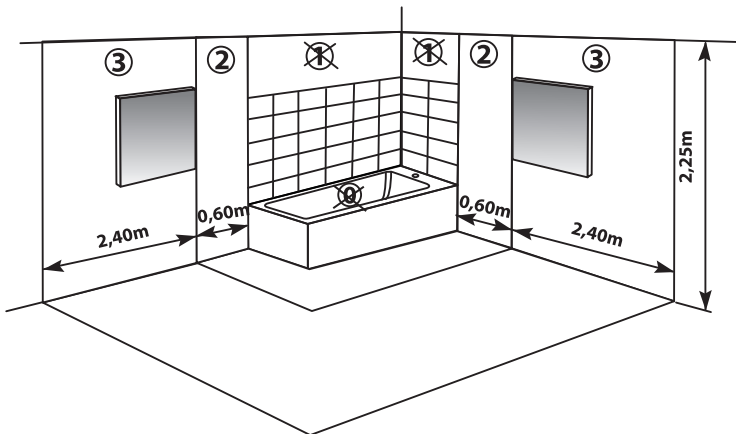

(F) Le fabricant préconise que l'installation et le branchement soient réalisés par un technicien qualifié. Avertissement : ce produit doit être installé uniquement dans le volume 3 d'une salle de bain, conformément aux exigences de la norme française d'installation électrique NF C 15-100.

Nous suggérons de contacter un électricien professionnel pour toute aide.

Avertissement : Le schéma de la notice est donné uniquement à titre d'exemple. si la configuration présentée sur le schéma ne correspond pas à celle de votre salle de bains, nous vous suggérons fortement de contacter un électricien professionnel pour réaliser l'installation selon la norme NF C 15-100

(NL) De fabrikant beveelt aan de installatie en de aansluiting toe te vertrouwen aan een gekwalificeerde technicus .

(D) Das Anbringen des Spiegelschranks sollte nur unter Berücksichtigung der Badinstallations vorschritt VDE 0100 Teil 701 durch einen Fachmann erfolgen .

(GB) The manufacturer recommends that the installation and the connection be done by a qualified technician .

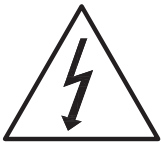

ATTENTION
Couper l'alimentation générale avant intervention
AANDACHT
Electrische voeding afkoppelen voor interventie
ACHTUNG
Netzleitung muss spannungsfrei sein
WARNING
Disconnect mains supply
before installation or maintenance

12

Etape
Stap
Stage
Schritt

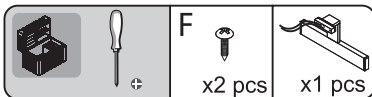

x2 pcs

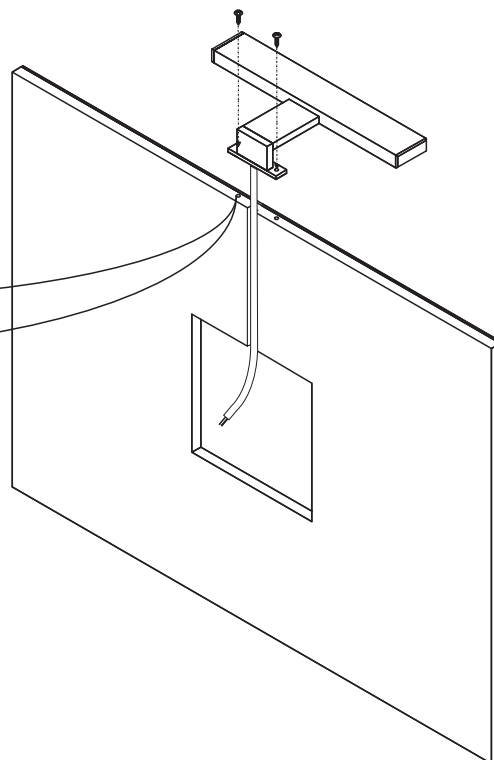
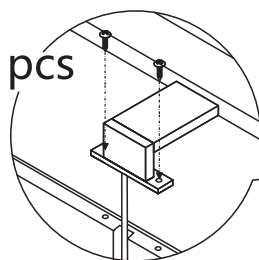

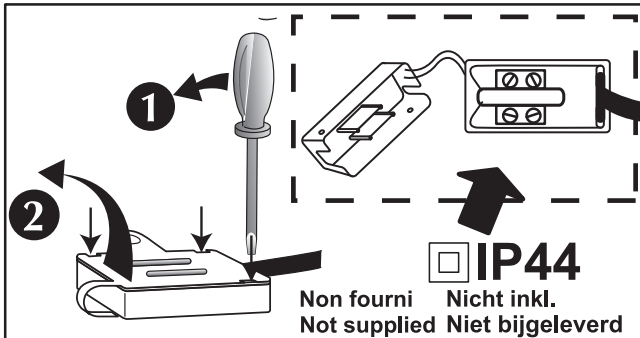

Cet appareil doit être raccordé à l'alimentation par l'intermédiaire d'une boîte de raccordement Classe 2, IP44 conformément à la norme NFC 15-100 et UTE C 15-801.
 Une fois installé en position d'utilisation les câbles de raccordement ne doivent être ni visibles ni accessibles, ni contraints.

Dit apparaat dient aangesloten worden aan het net d.m.v. een aansluitdoos Klasse 2, IP44 conform aan de norm NFC 15-100 en UTE C 15-801.
 Eens geïnstalleerd mogen de elektriciteitsdraden niet zichtbaar, aanraakbaar of aangespannen zijn.

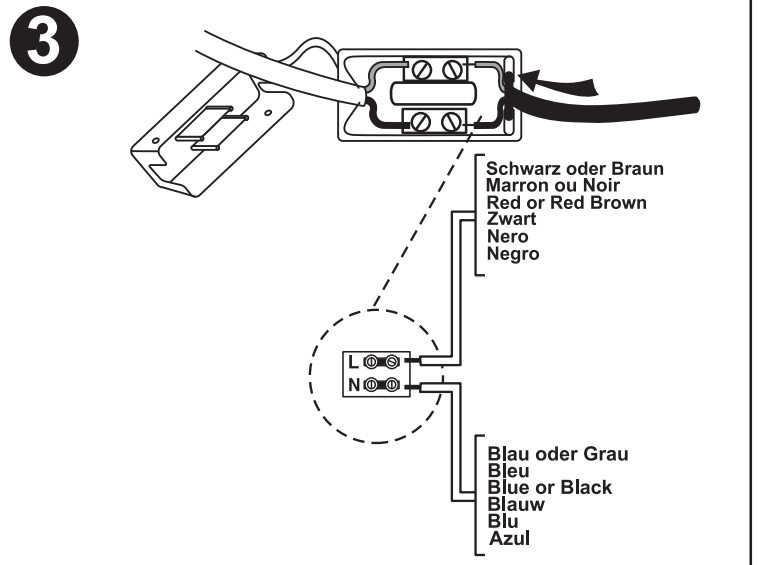

13

**Etape
 Stap
 Stage
 Schritt**

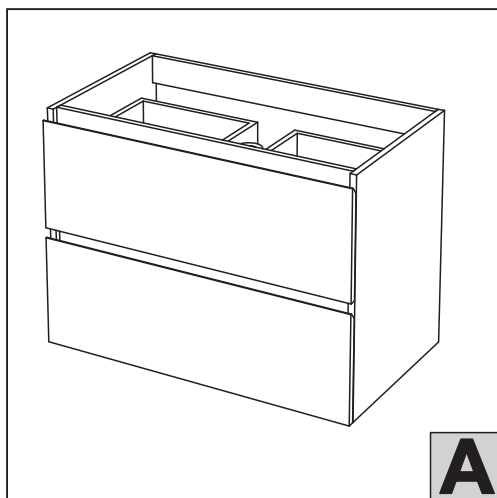
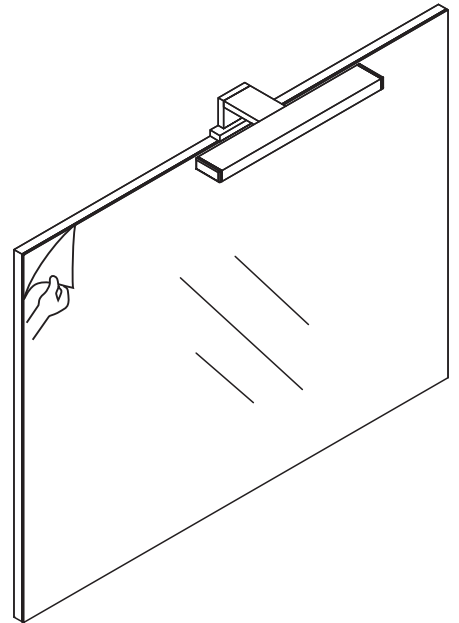
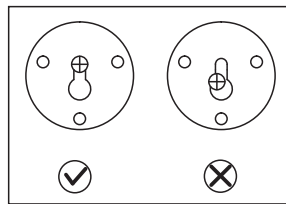
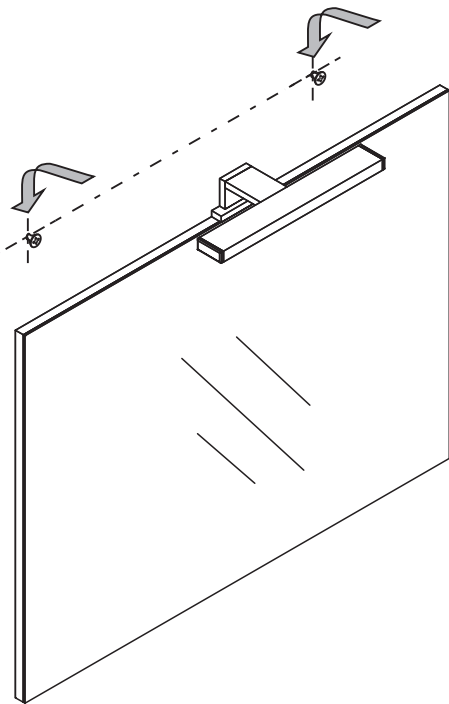

14

**Etape
 Stap
 Stage
 Schritt**

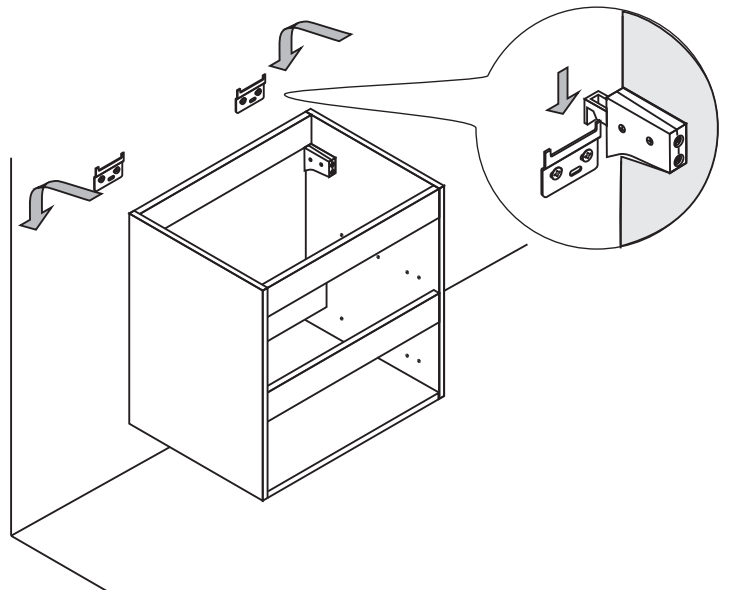

15

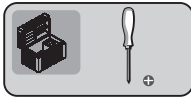

Etape
Step
Stage
Schritt

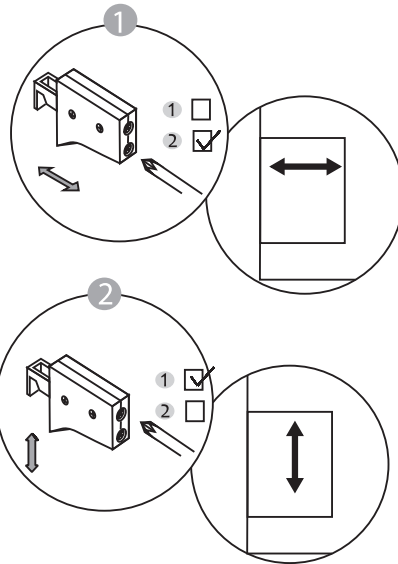
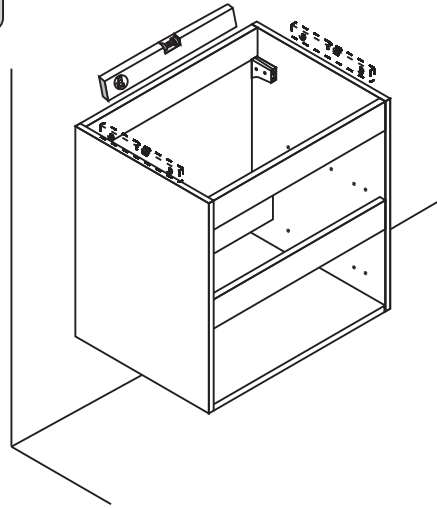

16

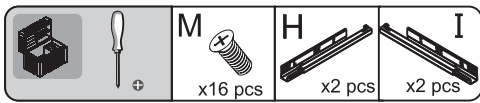

Etape
Step
Stage
Schritt

x8 pcs

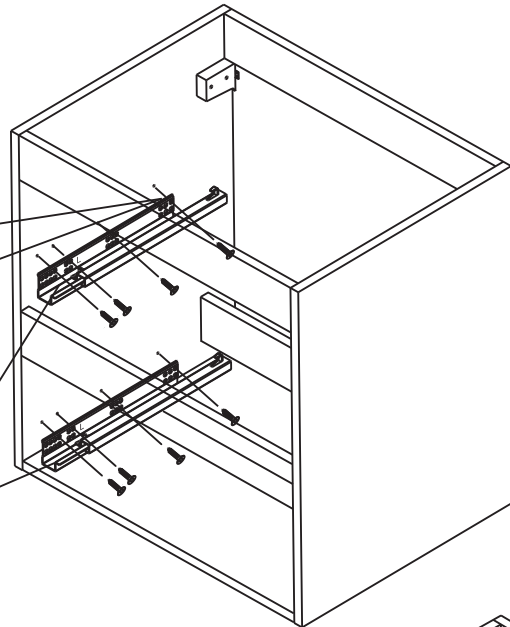
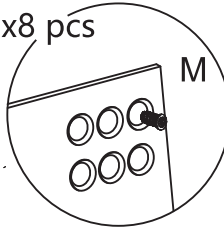

x2 pcs

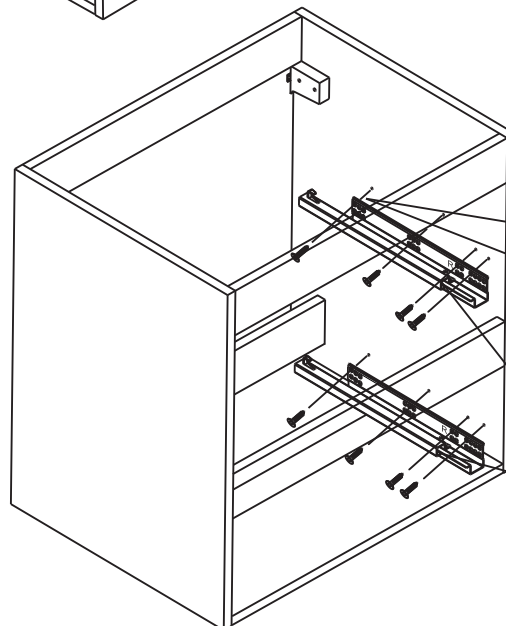
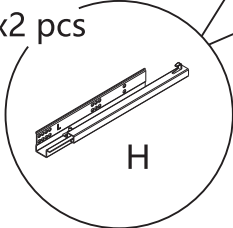

x8 pcs

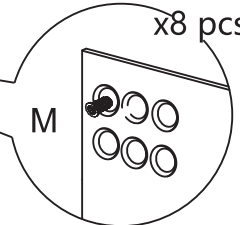

x2 pcs

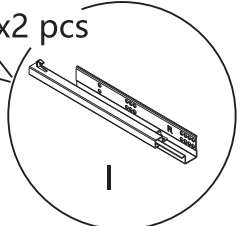

17

Etape
Stap
Stage
Schritt

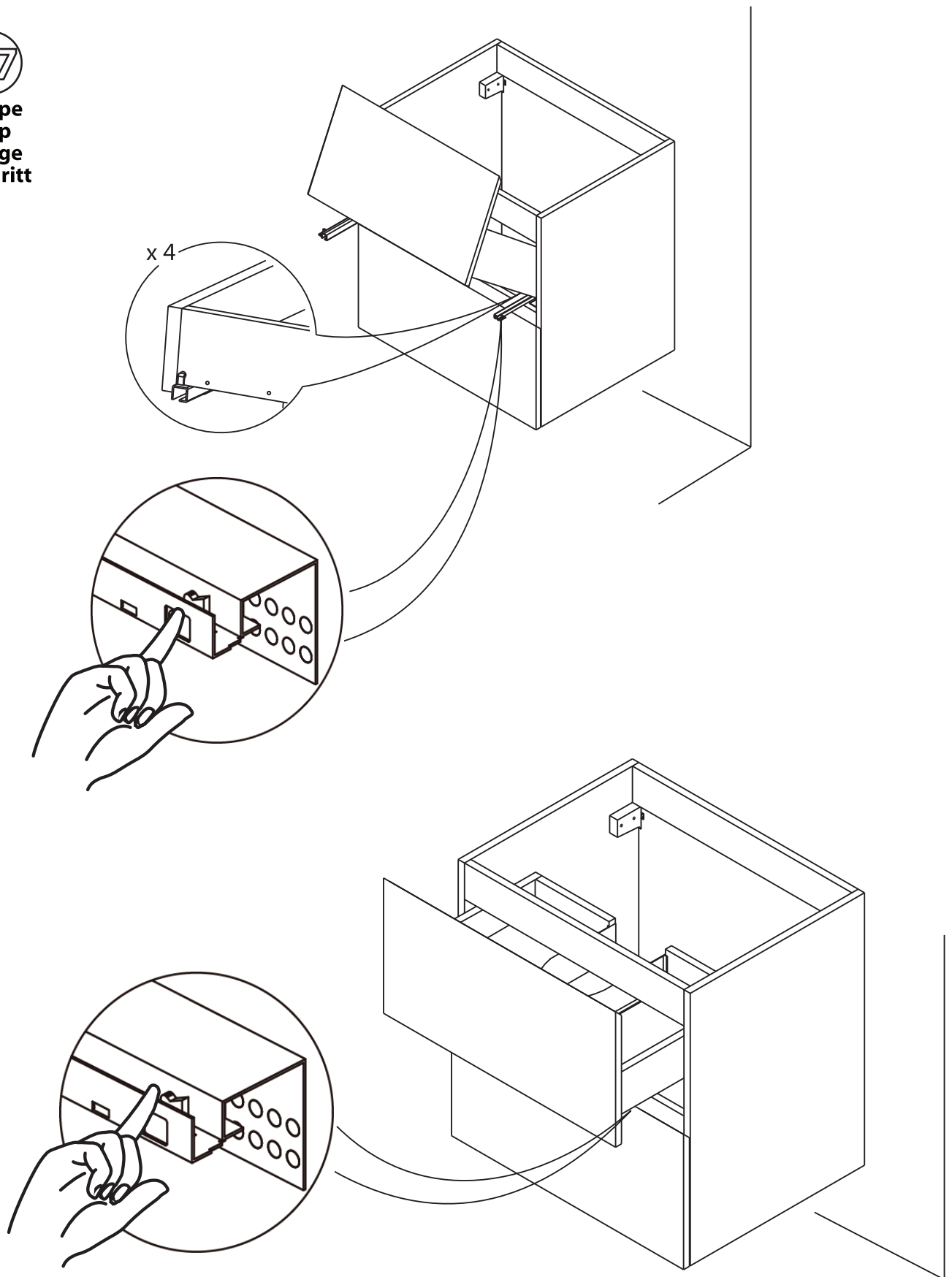

18

Etape
Step
Stage
Schritt

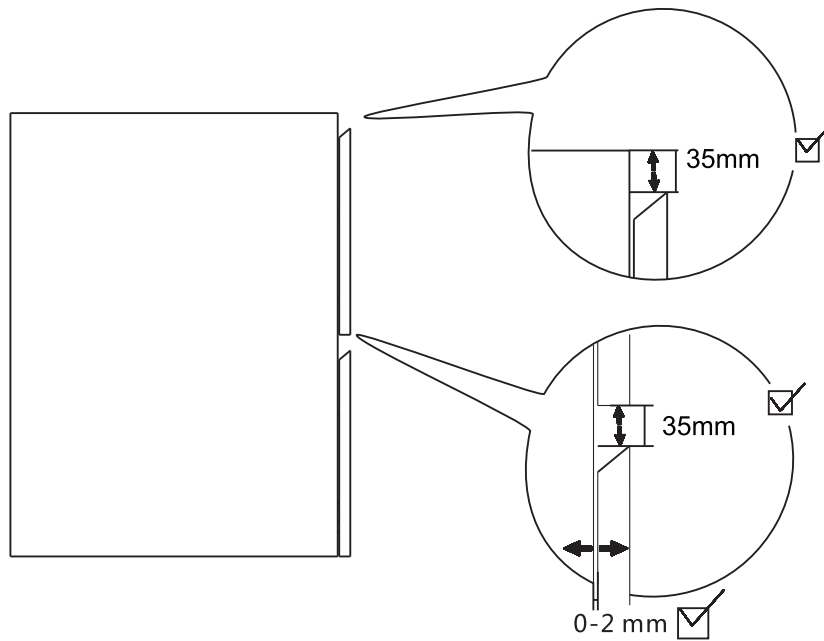

19

Etape
Step
Stage
Schritt

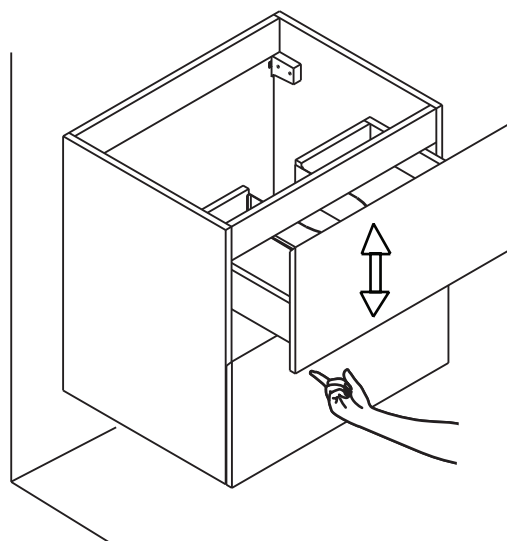

20

Etape
Step
Stage
Schritt

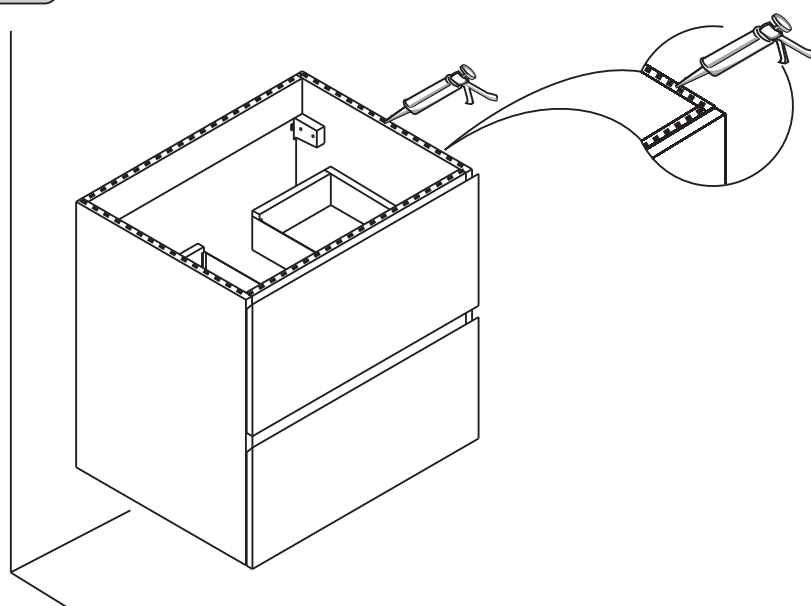
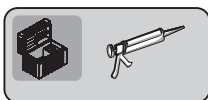

21

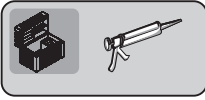

Etape
Step
Stage
Schritt

