

**11. Montageskizze / Assembly drawing / Schéma de montage / Montageset / Szkic montażu /
Monteringstegning**

9621978

22,5W + 15W LED
230 V~ 50 Hz



Bestimmungsgemäße Verwendung

Applications / Utilisation conforme / Beoogd gebruik / Użycie zgodnie z przeznaczeniem / Tiltentkt/tiltænkt anvendelse

(D) Ortsfeste Verwendung als Hängeleuchte im Innenbereich
(GB) Provided for stationary indoor use as pendant light.
(F) Utilisation stationnaire en tant que suspension d'intérieur

(NL) Vast gebruik als hanglamp binnenshuis
(PL) Do montażu stacjonarnego jako lampa sufitowa do wnętrza
(N/DK) Til stasjonært/stationær bruk/brug som pendellampe
innendørs/indendørs

Verwendete Symbole

Safety Precautions / Symboles utilises / Gebruikte symbolen / Stosowane symbole / Anvendte symboler

IP 20 

Lieferumfang

Package contents / Contenu de la livraison / Bij de levering inbegrepen / Zakres dostawy / Leveringsomfang

<ul style="list-style-type: none"> • 1 Hängeleuchte • Montagematerial • Montageanleitung 	<ul style="list-style-type: none"> • 1 Pendant light • Installation hardware • Mounting instructions 	<ul style="list-style-type: none"> • 1 Suspension • Matériel de montage • Instructions de montage
<ul style="list-style-type: none"> • 1 Hanglamp • Monteringsmateriale • Montagehandleiding 	<ul style="list-style-type: none"> • 1 Lampa wisząca • Elementy montażowe • Instrukcja montażu 	<ul style="list-style-type: none"> • 1 Pendellampe • Monteringsmateriale • Brukerveiledning/Brugervejledning

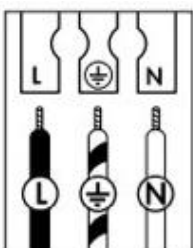
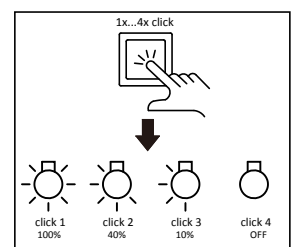
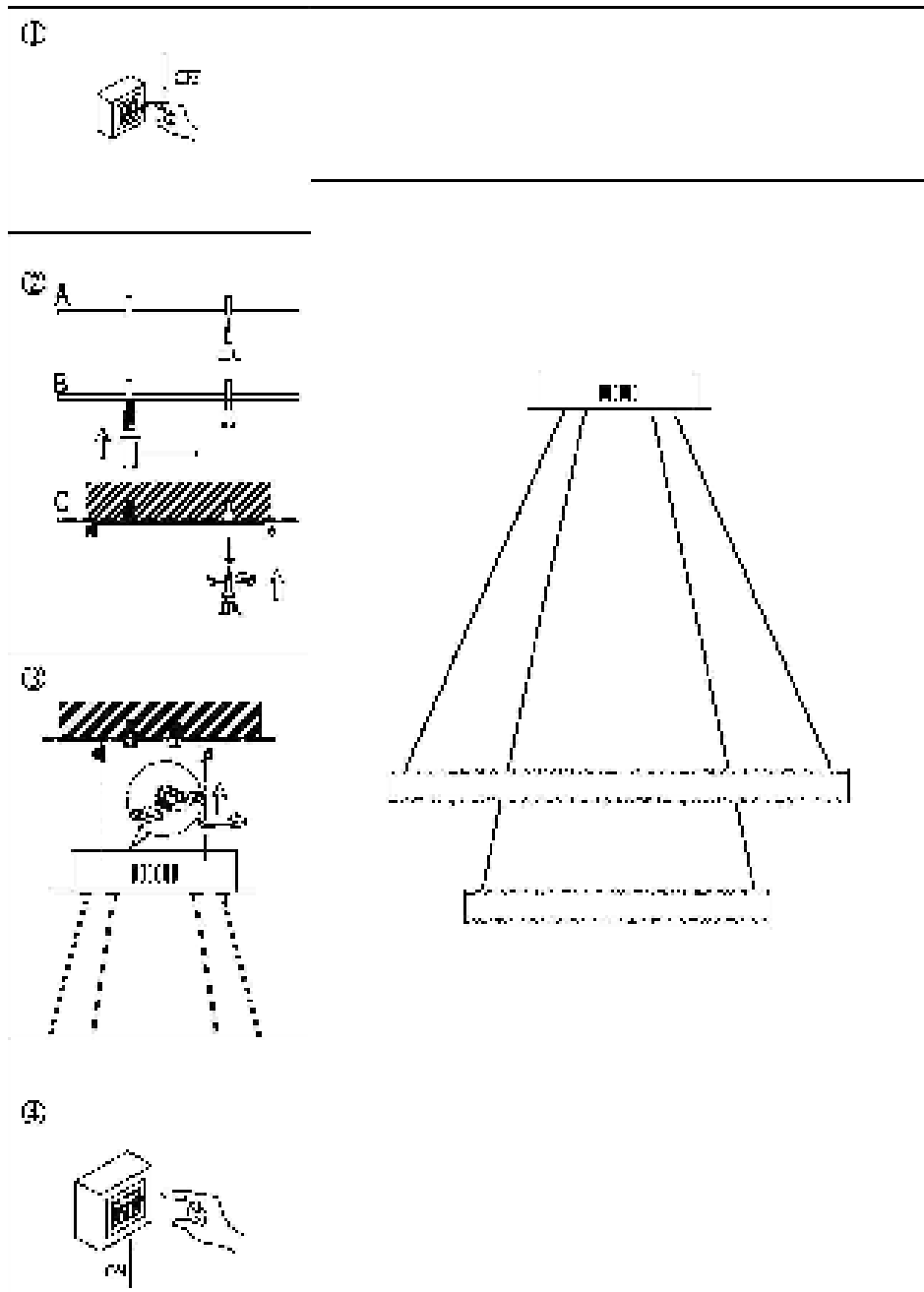

	(D) Deutsch	(GB) English	(F) Français	(NL) Nederlands	(PL) Polski	(N) Norsk / (DK) Dansk
L	Stromführender Leiter	Live conductor	Conducteur	Spanningvoerende draad	Przewód prądowy	Strømførende leder
PE	Schutzleiter	Earth conductor	Conducteur de protection (terre)	Aardkabel	Przewód uziemiający	Jordledningen
N	Neutralleiter	Neutral conductor	Conducteur neutre	Nulleider	Przewód zerowy	Nøytralleder/ Neutralleider