

**English**

**FEDERAL COMMUNICATION COMMISSION INTERFERENCE STATEMENT**  
 Note: This equipment has been tested and found to comply with the limits for a Class B digital device. Pursuant to Part 15 of the FCC Rules. These limits are designed to provide reasonable protection against harmful interference in a residential installation. This equipment generates, uses and can radiate radio frequency energy and, if not installed and used in accordance with the instructions, may cause harmful interference to radio communications. However, there is no guarantee that interference will not occur in a particular installation. If this equipment does cause harmful interference to radio or television reception, which can be determined by turning the equipment off and on, the user is encouraged to try to correct the interference by one or more of the following measures:  
 • Reorient or relocate the receiving antenna  
 • Increase the separation between the equipment and receiver  
 • Connect the equipment into an outlet on a circuit different from that to which the receiver is connected  
 • Consult the dealer or an experienced radio/TV technician for help  
**MODIFICATIONS:** Any changes or modifications not expressly approved by Kensington could void the user's authority to operate the equipment.

**FCC DECLARATION OF CONFORMITY COMPLIANCE STATEMENT**  
 This product complies with Part 15 of the FCC Rules. Operation is subject to two conditions:  
 (1) This device may not cause harmful interference, and (2) this device must accept any interference received, including interference that may cause undesired operation. As defined in Section 2.909 of the FCC Rules, the responsible party for this device is Kensington Computer Products Group, 333 Twin Dolphin Drive, Redwood Shores, CA 94065, USA.

**INDUSTRY CANADA CONFORMITY**  
 This Class [B] digital apparatus complies with Canadian ICES-003.

**CE DECLARATION OF CONFORMITY**  
 Kensington declares that this product is in compliance with the essential requirements and other relevant provisions of applicable EC directives.  
 For Europe, a copy of the Declaration of Conformity for this product may be obtained by clicking the Compliance Documentation link at [www.support.kensington.com](http://www.support.kensington.com).  
 Kensington and ACCO are registered trademarks of ACCO Brands. The Kensington Promise is a service mark of ACCO Brands. Windows and Windows XP are a registered trademark of Microsoft Corporation in the United States and other countries. Mac OS and PowerBook is a trademark of Apple Computer, Inc. registered in the U.S. and other countries. All other trademarks are the property of their respective owners. Patents pending.  
 © 2012 Kensington Computer Products Group, a division of ACCO Brands. Any unauthorized copying, duplicating, or other reproduction of the contents hereof is prohibited without written consent from Kensington Computer Products Group. All rights reserved. 06/12

901-2640-01  
 KL

**Français**

**DÉCLARATION DE CONFORMITÉ CE**  
 Kensington déclare que ce produit est conforme aux principales exigences et aux autres dispositions des directives CE applicables. Pour l'Europe, une copie de la Déclaration de conformité pour ce produit peut être obtenue en cliquant sur le lien "Documentation de conformité" sur le site [www.support.kensington.com](http://www.support.kensington.com).

**DÉCLARATION DE CONFORMITÉ D'INDUSTRIE CANADA**  
 Cet appareil numérique de la classe [B] est conforme à la norme NMB-003 du Canada.

**Deutsch**

**CE-KONFORMITÄTSERKLÄRUNG**  
 Kensington erklärt, dass dieses Produkt die wesentlichen Anforderungen und andere zutreffende Bestimmungen der geltenden EC-Vorschriften erfüllt. Für Europa finden Sie evtl. eine Kopie der Konformitätserklärung für dieses Produkt, indem Sie unter [www.support.kensington.com](http://www.support.kensington.com) auf den Link "Compliance Documentation" klicken.

**Nederlands**

**CE-VERKLARING VAN CONFORMITEIT**  
 Kensington verklaart dat dit product voldoet aan de essentiële vereisten en overige relevante bepalingen van de van toepassing zijnde EC-richtlijnen. In Europa is de conformiteitsverklaring voor dit product verkrijgbaar via de koppeling "Compliance Documentation" op [www.support.kensington.com](http://www.support.kensington.com).

**Italiano**

**DICHIARAZIONE DI CONFORMITÀ CE**  
 Kensington dichiara che questo prodotto è conforme ai requisiti essenziali e alle disposizioni delle direttive CE applicabili. Per una copia della Dichiarazione di conformità per l'Europa fare clic sul collegamento "Compliance Documentation" all'indirizzo [www.support.kensington.com](http://www.support.kensington.com).

**Español**

**DECLARACIÓN DE CONFORMIDAD DE LA CE**  
 Kensington declara que el presente producto cumple con los requisitos esenciales y otras disposiciones pertinentes de las directivas aplicables de la CE. Puede adquirirse una copia de la Declaración de conformidad del producto para Europa haciendo clic en el vínculo "Compliance Documentation" en [www.support.kensington.com](http://www.support.kensington.com).

**Magyar**

**EK MEGFELELŐSÉGI NYILATKOZÁS**  
 A Kensington vállalat kijelenti, hogy a termék megfelel az ide vonatkozó EK irányelvek alapvető követelményeinek és egyéb fontos rendelkezéseinek. Európában a termékre vonatkozó megfelelési nyilatkozat másolatát a [www.support.kensington.com](http://www.support.kensington.com) webhelyen található „Compliance Documentation” (Megfelelési dokumentáció) hivatkozással kaphatja meg.

**Čeština**

**PROHLÁŠENÍ O SOULADU S PŘEDPISY CE**  
 Společnost Kensington tímto prohlašuje, že tento výrobek odpovídá stanoveným požadavkům a jiným se vztahujícím ustanovením platných směrníc ES. Kopii tohoto Prohlášení o souladu s předpisy pro Evropu je možné získat po kliknutí na odkaz „Compliance Documentation” (dokumenty o souladu) na stránkách [www.support.kensington.com](http://www.support.kensington.com).

**Polski**

**DEKLARACJA ZGODNOŚCI WE**  
 Firma Kensington oświadcza, że ten produkt spełnia podstawowe wymagania i inne warunki odpowiednich dyrektyw WE. W Europie egzemplarz deklaracji zgodności tego produktu można otrzymać, klikając łącze „Compliance Documentation” w witrynie internetowej [www.support.kensington.com](http://www.support.kensington.com).

**Русский**

**ДЕКЛАРАЦИЯ О СООТВЕТСТВИИ ДИРЕКТИВЫ СОВЕТА ЕВРОПЫ**  
 Компания Kensington заявляет, что данный продукт соответствует основным требованиям и другим важным условиям соответствующих директив ЕС. Копию Декларации о соответствии для Европы на данный продукт можно быть получена на сайте "Compliance Documentation" (Документация о соответствии) на сайте [www.support.kensington.com](http://www.support.kensington.com).

**Português**

**DECLARAÇÃO DE CONFORMIDADE DA CE**  
 A Kensington declara que este produto está em conformidade com os requisitos essenciais e outras disposições relevantes das Diretivas da CE aplicáveis. Para a Europa, pode obter uma cópia da Declaração de Conformidade para este produto, ao clicar na ligação "Declaração de Conformidade", em [www.support.kensington.com](http://www.support.kensington.com).

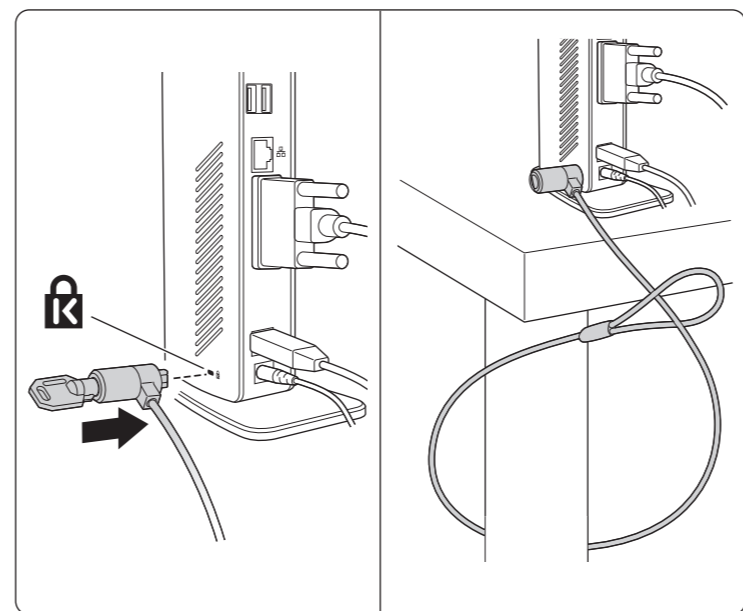

Kensington and the ACCO name and design are registered trademarks of ACCO Brands. The Kensington Promise is a service mark of ACCO Brands. All other registered and unregistered trademarks are the property of their respective owners.  
 ©2012 Kensington Computer Products Group, a division of ACCO Brands. Any unauthorized copying, duplicating, or other reproduction of the contents hereof is prohibited without written consent from Kensington Computer Products Group. All rights reserved. 07/12

**Technical Support / Assistance technique / Technischer Support / Technische ondersteuning / Supporto tecnico / Asistencia técnica / Műszaki támogatás / Technická podpora / Pomoc technická / Техническая поддержка / Assistenza técnica**

Australia	1 300 881 931	Nederland	010 713 1882
Belgie / Belgique	02 401 2395	New Zealand	0800 539 26273
Brasil	14 3235-4003	Norway	8001 7520
Canada	1 800 268 3447	Osterreich	0800 677 873
Denmark	80 250966	Polska	22 570 18 00
Deutschland	0692 222 3654	Portugal	800855802
España	911 146 735	Russia	007 495 933 5163
Finland	0800 9 15697	Schweiz / Suisse	044 580 6667
France	01 7671 0404	Sweden	08 5033 6577
Hungary	06 20 9430 612	United Kingdom	0203 364 5390
Ireland	01 431 1395	United States	1 800 535 4242
Italia	02 3604 7030	International Toll	+31 53 484 9135
México	55 15 00 57 00		

**Two Year Limited Warranty**  
 Complete warranty terms are available at: [www.warranty.kensington.com](http://www.warranty.kensington.com)

**The Kensington Promise™**  
 Complete warranty terms are available at: [www.warranty.kensington.com](http://www.warranty.kensington.com)

**For technical support visit:**  
 Register Now!  
 Enregistrer maintenant!  
 Jetzt registrieren!  
 Nu registreren!  
 Registrar ahora!  
 Registra adesso!

**ACCIO**  
 Kensington Computer Products Group  
 A Division of ACCO Brands  
 333 Twin Dolphin Drive,  
 Redwood Shores, CA 94065

**ACCO Brands Europe**  
 Oxford House  
 Oxford Road  
 Aylesbury  
 Bucks, HP21 8SZ  
 United Kingdom

**ACCO Brands Canada**  
 5 Precinct Court  
 Brampton  
 Ontario, L6S 6B7  
 Canada

**ACCO Australia**  
 Level 2, 8 Lind St  
 Botany NSW 2019  
 PO Box 311  
 Rosebery NSW 1445  
 Australia

**ACCIO MEXICANA, S.A. DE C.V.**  
 Avenida Circuito de la Industria  
 Norte 6  
 Parque Industrial Lerma,  
 Lerma, 52000 Estado de Mexico  
 MEXICO

**Acco Brands Chile S.A.**  
 Avenida San Isidro  
 Escribá de Balaguer N°5773  
 Vitacura, C.P 7640870  
 Santiago, Chile

**Tilbra Produtos de Papelaria Ltda.**  
 Rua Amazonas, 6-9  
 Bairro, CEP 17013-900  
 São Paulo, Brasil

**Kensington®**

**USB 3.0 Docking Station**  
 with VGA/DVI/HDMI Video sd3000v/sd3500v

**QUICK START GUIDE**  
**GUIDE DE DEMARRAGE RAPIDE**  
**KURZANLEITUNG**  
**SNELSTARTGIDS**  
**GUIDA RAPIDA**  
**GYORSKALAUZ**  
**PŘÍRUČKA ZAČÍNÁME**  
**СЗЫВКИ СТАРТ**  
**КРАТКОЕ РУКОВОДСТВО**  
**ПОЛЬЗОВАТЕЛЯ**  
**MANUAL DE INICIO RÁPIDO**

**Register Now!**  
 Enregistrer maintenant!  
 Jetzt registrieren!  
 Nu registreren!  
 Registrar ahora!  
 Registra adesso!

**Regisztráljon most!**  
 Zaregistrujte se nyní!  
 Zarejestruj sie!  
 Зарегистрироваться!  
 Regístrate agora!

[register.kensington.com](http://register.kensington.com)