

<b>DE</b>	Gebrauchsanleitung / Montageanleitung	<b>2</b>
<b>FR</b>	Mode d'emploi / Instructions de montage	<b>3</b>
<b>EN</b>	Instructions for use / assembly instructions	<b>4</b>
<b>IT</b>	Istruzioni per l'uso / Istruzioni per Installazione	<b>5</b>
<b>ES</b>	Modo de empleo / Instrucciones de montaje	<b>6</b>
<b>NL</b>	Gebruiksaanwijzing / Handleiding	<b>7</b>
<b>DK</b>	Brugsanvisning / Monteringsvejledning	<b>8</b>
<b>PT</b>	Instruções para uso / Manual de Instalação	<b>9</b>
<b>PL</b>	Instrukcja obsługi / Instrukcja montażu	<b>10</b>
<b>CS</b>	Návod k použití / Montážní návod	<b>11</b>
<b>SK</b>	Návod na použitie / Montážny návod	<b>12</b>
<b>ZH</b>	用户手册 / 组装说明	<b>13</b>
<b>RU</b>	Руководство пользователя / Инструкция по монтажу	<b>14</b>
<b>HU</b>	Használati útmutató / Szerelési útmutató	<b>15</b>
<b>FI</b>	Käyttöohje / Asennusohje	<b>16</b>
<b>SV</b>	Bruksanvisning / Monteringsanvisning	<b>17</b>
<b>LT</b>	Vartotojo instrukcija / Montavimo instrukcijos	<b>18</b>
<b>HR</b>	Upute za uporabu / Uputstva za instalaciju	<b>19</b>
<b>TR</b>	Kullanım kılavuzu / Montaj kılavuzu	<b>20</b>
<b>RO</b>	Manual de utilizare / Instrucțiuni de montare	<b>21</b>
<b>EL</b>	Οδηγίες χρήσης / Οδηγία συναρμολόγησης	<b>22</b>
<b>SL</b>	Navodilo za uporabo / Navodila za montažo	<b>23</b>
<b>ET</b>	Kasutusjuhend / Paigaldusjuhend	<b>24</b>
<b>LV</b>	Lietošanas pamācība / Montāžas instrukcija	<b>25</b>
<b>SR</b>	Uputstvo za upotrebu / Uputstvo za montažu	<b>26</b>
<b>NO</b>	Bruksanvisning / Montasjeveiledning	<b>27</b>
<b>BG</b>	Инструкция за употреба / Ръководство за монтаж	<b>28</b>
<b>SQ</b>	Udhëzuesi i përdorimit / Udhëzime rreth montimit	<b>29</b>
<b>AR</b>	دليل الاستخدام / تعليمات التجميع	<b>30</b>

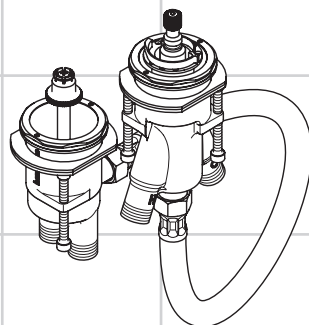

1355018X



## Sicherheitshinweise

- Bei der Montage müssen zur Vermeidung von Quetsch- und Schnittverletzungen Handschuhe getragen werden.
- Große Druckunterschiede zwischen den Kalt- und Warmwasseranschlüssen müssen ausgeglichen werden.

## Montagehinweise

- Vor der Montage muss das Produkt auf Transportschäden untersucht werden.
- Die Leitungen und die Armatur müssen nach den gültigen Normen montiert, gespült und geprüft werden.
- Die in den Ländern jeweils gültigen Installationsrichtlinien sind einzuhalten.
- Um die Anschluss-Schläuche überprüfen zu können, muss eine Revisionsöffnung vorhanden sein. Es wird empfohlen, die Armatur mit einer "festen Verrohrung" anzuschließen.

## Technische Daten

Betriebsdruck:	max. 1 MPa
Empfohlener Betriebsdruck:	0,1 - 0,5 MPa
Prüfdruck:	1,6 MPa
	(1 MPa = 10 bar = 147 PSI)
Heißwassertemperatur:	max. 70°C
Empfohlene Heißwassertemperatur:	65°C
Thermische Desinfektion:	max. 70°C / 4 min
Anschlüsse G 1/2:	kalt rechts - warm links

Das Produkt ist ausschließlich für Trinkwasser konzipiert!

## Symbolerklärung



Kein essigsäurehaltiges Silikon verwenden!



**Rohrunterbrecher** (siehe Seite 32)



**Maße** (siehe Seite 33)



**Durchflussdiagramm**  
(siehe Seite 33)

freier Durchfluss

- ① Abgang 1
- ② Abgang 2



**Serviceteile** (siehe Seite 35)



**Prüfzeichen** (siehe Seite 36)



**Wartung**

- Rückflussverhinderer müssen gemäß DIN EN 1717 regelmäßig in Übereinstimmung mit nationalen oder regionalen Bestimmungen auf ihre Funktion geprüft werden (mindestens einmal jährlich).
- Um die Leichtgängigkeit der Regeleinheit zu gewährleisten, sollte der Thermostat von Zeit zu Zeit auf ganz warm und ganz kalt gestellt werden.





## Consignes de sécurité

- ⚠ Lors du montage, porter des gants de protection pour éviter toute blessure par écrasement ou coupure.
- ⚠ Il est conseillé d'équilibrer les pressions de l'eau chaude et froide.

## Instructions pour le montage

- Avant son montage, s'assurer que le produit n'a subi aucun dommage pendant le transport
- Les conduites et la robinetterie doivent être montés, rincés et contrôlés selon les normes en vigueur.
- Les directives d'installation en vigueur dans le pays concerné doivent être respectées.
- Pour des travaux d'entretien prévoir obligatoirement une trappe de visite.  
Il est conseillé de raccorder la robinetterie avec une tuyauterie fixe.

## Informations techniques

Pression de service autorisée:	max. 1 MPa
Pression de service conseillée:	0,1 - 0,5 MPa
Pression maximum de contrôle:	1,6 MPa
	(1 MPa = 10 bar = 147 PSI)
Température d'eau chaude:	max. 70 °C
Température recommandée:	65 °C
Désinfection thermique:	max. 70 °C / 4 min
Raccordement G 1/2:	froide à droite - chaude à gauche

Le produit est exclusivement conçu pour de l'eau potable!

## Description du symbole



Ne pas utiliser de silicone contenant de l'acide acétique!



**Disconnecteur** (voir pages 32)



**Dimensions** (voir pages 33)



**Diagramme du débit**  
(voir pages 33)

débit libre

- ① Sortie 1
- ② Sortie 2



**Pièces détachées** (voir pages 35)



**Classification acoustique et débit** (voir pages 36)



**Entretien**

- Les clapets anti-retour doivent être examinés régulièrement conformément à la norme EN 1717 ou conformément aux dispositions nationales ou régionales quant à leur fonction (au moins une fois par an).
- Pour assurer le mouvement facile de l'élément thermostatique, le thermostat devrait être placé de temps en temps en position très chaude et très froide.





## Safety Notes

- △ Gloves should be worn during installation to prevent crushing and cutting injuries.
- △ The hot and cold supplies must be of equal pressures.

## Installation Instructions

- Prior to installation, inspect the product for transport damages.
- The pipes and the fixture must be installed, flushed and tested as per the applicable standards.
- The plumbing codes applicable in the respective countries must be observed.
- There must be an access door for maintenance.  
It will be recommended that the faucet will be connected with solid pipes.

## Technical Data

Operating pressure:	max. 1 MPa
Recommended operating pressure:	0,1 - 0,5 MPa
Test pressure:	1,6 MPa
	(1 MPa = 10 bar = 147 PSI)
Hot water temperature:	max. 70°C
Recommended hot water temp.:	65°C
Thermal disinfection:	max. 70°C / 4 min
Connections G 1/2:	cold right - hot left

The product is exclusively designed for drinking water!

## Symbol description



Do not use silicone containing acetic acid!



**Pipe interrupter** (see page 32)



**Dimensions** (see page 33)



**Flow diagram**  
(see page 33)

free flow

- ① Outlet 1
- ② Outlet 2



**Spare parts** (see page 35)



**Test certificate** (see page 36)





**Maintenance**

- The check valves must be checked regularly according to DIN EN 1717 in accordance with national or regional regulations (at least once a year).
- To guarantee the smooth running of the thermostat, it is necessary from time to time to turn the thermostat from total hot to total cold.





## Indicazioni sulla sicurezza

-  Durante il montaggio, per evitare ferite da schiacciamento e da taglio bisogna indossare guanti protettivi.
-  Attenzione! Compensare le differenze di pressione tra i collegamenti dell'acqua fredda e dell'acqua calda.

## Istruzioni per il montaggio

- Prima del montaggio è necessario controllare che non ci siano stati danni durante il trasporto.
- Montare, lavare e controllare tubature e rubinetteria rispettando le norme correnti.
- Vanno rispettate le direttive di installazione nazionali vigenti nel rispettivo paese.
- È necessaria un accesso di ispezione per la manutenzione.  
Si raccomanda di collegare la rubinetteria con una tubatura a sicura tenuta.

## Dati tecnici

Pressione d'uso:	max. 1 MPa
Pressione d'uso consigliata:	0,1 - 0,5 MPa
Pressione di prova:	1,6 MPa (1 MPa = 10 bar = 147 PSI)
Temperatura dell'acqua calda:	max. 70°C
Temp. dell'acqua calda consigliata:	65°C
Disinfezione termica:	max. 70°C / 4 min
Raccordi G 1/2:	fredda a destra - calda a sinistra

Il prodotto è concepito esclusivamente per acqua potabile!

## Descrizione simbolo



Non utilizzare silicone contenente acido acetico!



**Valvola antiriflusso**  
(vedi pagg. 32)



**Ingombri** (vedi pagg. 33)



**Diagramma flusso**  
(vedi pagg. 33)

portata libero

- ① Uscita 1
- ② Uscita 2



**Parti di ricambio** (vedi pagg. 35)



**Segno di verifica** (vedi pagg. 36)



## Manutenzione

- La valvola di non ritorno deve essere controllata regolarmente come da DIN EN 1717, secondo le normative nazionali e regionali (almeno una volta all'anno).
- Per garantire la scorrevolezza dell'elemento di regolazione, di tanto in tanto si dovrebbe regolare il termostatico passando da tutto caldo a tutto freddo.





## Indicaciones de seguridad

- ⚠ Durante el montaje deben utilizarse guantes para evitar heridas por aplastamiento o corte.
- ⚠ Grandes diferencias de presión en servicio entre agua fría y agua caliente deben equilibrarse.

## Indicaciones para el montaje

- Antes del montaje se debe examinarse el producto contra daños de transporte.
- Los conductos y la grifería deben montarse, lavarse y comprobarse según las normas vigentes.
- Es obligatorio el cumplimiento de las directrices de instalación vigentes en el país respectivo.
- Para mantenimiento tiene que haber un registro!  
Se aconseja conectar los cuerpos con una tubería semi rígida.

## Datos técnicos

Presión en servicio:	max. 1 MPa
Presión recomendada en servicio:	0,1 - 0,5 MPa
Presión de prueba:	1,6 MPa (1 MPa = 10 bar = 147 PSI)
Temperatura del agua caliente:	max. 70 °C
Temp. recomendada del agua caliente:	65 °C
Desinfección térmica:	max. 70 °C / 4 min
Racores excéntricos G 1/2:	a la derecha frío - a la izquierda caliente

El producto ha sido concebido exclusivamente para agua potable.

## Descripción de símbolos



No utilizar silicona que contiene ácido acético!



### Interuptor de tubería

(ver página 32)



### Dimensiones (ver página 33)



### Diagrama de circulación

(ver página 33)

caudal libre

- ① Salida 1
- ② Salida 2



### Repuestos (ver página 35)



### Marca de verificación

(ver página 36)



### Mantenimiento

- Las válvulas anti-retorno tienen que ser controladas regularmente según la norma DIN EN 1717, en acuerdo con las regulaciones nacionales o regionales (una vez al año, por lo menos).
- Para garantizar el funcionamiento duradero del termostato, el mando del mismo debería girarse de vez en cuando del extremo frío al extremo caliente.





## Veiligheidsinstructies

- ⚠ Bij de montage moeten ter voorkoming van knel- en snijwonden handschoenen worden gedragen.
- ⚠ Grote drukverschillen tussen de koud- en warmwatertoevoer dienen vermeden te worden.

## Montage-instructies

- Vóór de montage moet het product gecontroleerd worden op transportschade.
- De leidingen en armaturen moeten gemonteerd, gespeeld en gecontroleerd worden volgens de geldige normen.
- De in de overeenkomstige landen geldende installatierichtlijnen moeten nageleefd worden.
- Voor eventuele reparatiewerkzaamheden moet een revisieluik zijn aangebracht.  
Het is aanbevolen de kraan met starre leidingen aan te sluiten.

## Technische gegevens

Werkdruk: max.	max. 1 MPa
Aanbevolen werkdruk:	0,1 - 0,5 MPa
Getest bij:	1,6 MPa
	(1 MPa = 10 bar = 147 PSI)
Temperatuur warm water:	max. 70 °C
Aanbevolen warm water temp.:	65 °C
Thermische desinfectie:	max. 70 °C / 4 min
Aansluitingen G 1/2:	koud rechts - warm links

Het product is uitsluitend ontworpen voor drinkwater!

## Symboolbeschrijving



Gebruik geen zuurhoudende silicone!



**Buisbeluchter** (zie blz. 32)



**Maten** (zie blz. 33)



**Doorstroombiagram**  
(zie blz. 33)

vrije doorstroom

- ① Uitgang 1
- ② Uitgang 2



**Service onderdelen** (zie blz. 35)



**Keurmerk** (zie blz. 36)



**Onderhoud**

- Keerkleppen moeten volgens DIN EN 1717 regelmatig en volgens plaatselijk geldende eisen op het functioneren gecontroleerd worden. (Tenminste een keer per jaar)
- Om het soepel lopen van de regelaar te garanderen moet de thermostaat van tijd tot tijd op heel koud en heel warm worden ingesteld.



**Montage** (zie blz. 31)



## Sikkerhedsanvisninger

- △ Ved monteringen skal der bruges handsker for at undgå kvæstelser og snitsår.
- △ Større trykforskelle mellem koldt og varmt vand bør udjævnes.

## Monteringsanvisninger

- Før monteringen skal produktet kontrolleres for transportskader.
- Ledningerne og armaturerne skal monteres, skylles og kontrolleres iht. de gældende standarder.
- Installationsbestemmelserne, der gælder i det enkelte land, skal overholdes.
- For at kunne servicere armaturet, skal der laves en inspektionslem.  
Det anbefales, at armaturet tilsluttes med faste rør.

## Tekniske data

Driftstryk:	max. 1 MPa
Anbefalet driftstryk:	0,1 - 0,5 MPa
Prøvetryk:	1,6 MPa
	(1 MPa = 10 bar = 147 PSI)
Varmtvandstemperatur:	max. 70°C
Anbefalet varmtvandstemperatur:	65°C
Termisk desinfektion:	max. 70°C / 4 min
Tilslutninger G 1/2:	Koldt højre - varmt venstre

Produktet er udelukkende beregnet til drikkevand!

## Symbolbeskrivelse



Der må ikke benyttes eddikesyreholdig silikone!



**Rørafbryder** (se s. 32)



**Målene** (se s. 33)



**Gennemstrømningsdiagram**  
(se s. 33)

fri gennemstrømning

- ① Afgang 1
- ② Afgang 2



**Reserve dele** (se s. 35)



**Godkendelse** (se s. 36)



**Service**

- Ifølge DIN EN 1717 skal gennemstrømningsbegrænsere i overensstemmelse med nationale regler afprøves regelmæssigt (mindst en gang om året).
- For at sikre optimal funktion af termostaten, bør termostaten fra tid til anden motioneres (stilles skiftevis helt varm og helt kold).







## Avisos de segurança

- ⚠ Durante a montagem devem ser utilizadas luvas de protecção, de modo a evitar ferimentos resultantes de entalamentos e de cortes.
- ⚠ Grandes diferenças entre as pressões das águas quente e fria devem ser compensadas.

## Avisos de montagem

- Antes da montagem deve-se controlar o produto relativamente a danos de transporte.
- As tubagens e a torneira têm que ser montadas, enxaguadas e verificadas de acordo com as normas em vigor.
- A prescrições de instalação válidas nos respetivos países devem ser respeitadas.
- Tem que ter um painel de acesso para manutenção. É recomendável instalar a torneira com tubos rígidos.

## Dados Técnicos

Pressão de funcionamento:	max. 1 MPa
Pressão de func. recomendada:	0,1 - 0,5 MPa
Pressão testada:	1,6 MPa (1 MPa = 10 bar = 147 PSI)
Temperatura da água quente:	max. 70 °C
Temp. água quente recomendada:	65 °C
Desinfecção térmica:	max. 70 °C / 4 min
Ligações G 1/2:	fria à direita - quente à esquerda

Este produto foi única e exclusivamente concebido para água potável!

## Descrição do símbolo



Não utilizar silicone que contenha ácido acético!



**Válvula anti-retorno**  
(ver página 32)



**Medidas** (ver página 33)



**Fluxograma**  
(ver página 33)

caudal livre

- ① Saída 1
- ② Saída 2



**Peças de substituição**  
(ver página 35)



**Marca de controlo** (ver página 36)



**Manutenção**

- As válvulas anti-retorno devem ser verificadas regularmente de acordo com a DIN EN 1717 segundo os regulamentos nacionais ou regionais (pelo menos uma vez por ano).
- Para garantir um funcionamento suave do elemento termostático é necessário de vez em quando rodar totalmente o manípulo da termostática da posição quente para a fria.





## Wskazówki bezpieczeństwa

- ⚠ Aby uniknąć zranień na skutek zgniecenia lub przecięcia, podczas montażu należy nosić rękawice ochronne.
- ⚠ Znaczne różnice ciśnień na doptywach ciepłej i zimnej wody muszą zostać wyrównane.

## Wskazówki montażowe

- Przed montażem należy skontrolować produkt pod kątem szkód transportowych.
- Przewody i armatura muszą być montowane, płukane i kontrolowane według obowiązujących norm.
- Należy przestrzegać wytycznych instalacyjnych obowiązujących w danym kraju.
- Aby móc sprawdzić węże przyłączeniowe, musi istnieć otwór rewizyjny.  
Zaleca się podłączyć armaturę za pomocą "rur trwałych"

## Dane techniczne

Ciśnienie robocze:	maks. 1 MPa
Zalecane ciśnienie robocze:	0,1 - 0,5 MPa
Ciśnienie próbne:	1,6 MPa (1 MPa = 10 bary = 147 PSI)
Temperatura wody gorącej:	maks. 70 °C
Zalecana temperatura wody gorącej:	65 °C
Dezynfekcja termiczna:	maks. 70 °C / 4 min
Przyłącza G 1/2:	Zimna z prawej - Ciepła z lewej

Produkt przeznaczony wyłącznie do wody pitnej!

## Opis symbolu



Nie stosować silikonów zawierających kwas octowy!



**Przerzywacz rurowy**  
(patrz strona 32)



**Wymiary** (patrz strona 33)



**Schemat przepływu**  
(patrz strona 33)

swobodny przepływ

- ① Wylot 1
- ② Wylot 2



**Części serwisowe** (patrz strona 35)



**Znak jakości** (patrz strona 36)



## Konserwacja

- Zgodnie z normą DIN EN 1717, krajowymi i miejscowymi przepisami, działanie zabezpieczeń przed przepływem zwrotnym musi być kontrolowane (przynajmniej raz w roku).
- Aby zachować łatwość obsługi termostatu, od czasu do czasu należy go przekręcić na całkiem zimną i na całkiem ciepłą wodę.





## **Bezpečnostní pokyny**

- ⚠ Pro zabránění řezným zraněním a pohmožděninám je nutné při montáži nosit rukavice.
- ⚠ Je nutné vyrovnat velké rozdíly tlaku mezi přípoji studené a teplé vody.

## **Pokyny k montáži**

- Před montáží je třeba produkt zkontrolovat, zda nebyl při transportu poškozen.
- Vedení a armatura musí být namontovány, propláchnuty a otestovány podle platných norem.
- Je třeba dodržovat montážní pravidla platné v dané zemi.
- Pro kontrolu připojovacích hadic musí být k dispozici revizní šachta.  
Doporučuje se armaturu připojit "pevnou instalací".

## **Technické údaje**

Provozní tlak:	max. 1 MPa
Doporučený provozní tlak:	0,1 - 0,5 MPa
Zkušební tlak:	1,6 MPa
	(1 MPa = 10 bar = 147 PSI)
Teplota horké vody:	max. 70 °C
Doporučená teplota horké vody:	65 °C
Tepelná desinfekce:	max. 70 °C / 4 min
Přípoje G 1/2:	studená vpravo - teplá vlevo

Výrobky Hansgrohe jsou vhodné pro přímý kontakt s pitnou vodou.

## **Popis symbolů**



Nepoužívat silikon s obsahem kyseliny octové!



**oddělovač trubky** (viz strana 32)



**Rozměry** (viz strana 33)



**Diagram průtoku**  
(viz strana 33)

volný průtok

- ① odpad 1
- ② odpad 2



**Servisní díly** (viz strana 35)



**Zkušební značka** (viz strana 36)



**Údržba**

- U zpětných ventilů se musí podle DIN EN 1717 v souladu s národními nebo regionálními předpisy testovat jejich funkčnost (alespoň jednou ročně).
- Aby byl zajištěn lehký chod regulační jednotky, měl by se termostat čas od času nastavit na úplně horkou a úplně studenou vodu.





## Bezpečnostné pokyny

- △ Pri montáži musíte nosiť rukavice, aby ste predišli pomliaždeninám a rezným poraneniam.
- △ Veľké rozdiely v tlaku medzi prípojkami studenej a teplej vody musia byť vyrovnané.

## Pokyny pre montáž

- Pred montážou musíte produkt skontrolovať, či nebol počas transportu poškodený.
- Ledningarna och blandaren måste monteras, spolás igenom och kontrolleras enligt de gällande normerna.
- Je potrebné dodržiavať smernice o inštalácii, ktoré sú práve teraz platné v krajinách.
- Aby bolo možné skontrolovať pripojovacie hadice, musí byť k dispozícii revízny otvor.  
Odporúča sa, aby sa batéria pripojila pomocu pevného potrubia.

## Technické údaje

Prevádzkový tlak:	max. 1 MPa
Doporučený prevádzkový tlak:	0,1 - 0,5 MPa
Skúšobný tlak:	1,6 MPa (1 MPa = 10 bar = 147 PSI)
Teplota teplej vody:	max. 70 °C
Doporučená teplota teplej vody:	65 °C
Termická dezinfekcia:	max. 70 °C / 4 min
Prípoje G 1/2:	studená vpravo - teplá vľavo

Výrobok je koncipovaný výhradne pre pitnú vodu!

## Popis symbolov



Nepoužívať silikón s obsahom kyseliny octovej!



**Prerušenie potrubia**  
(viď strana 32)



**Rozmery** (viď strana 33)



**Diagram prietoku**  
(viď strana 33)

volný prietok

- ① odtok 1
- ② odtok 2



**Servisné diely** (viď strana 35)



**Osvedčenie o skúške**  
(viď strana 36)



**Údržba**

- Pri spätných ventiloch sa musí podľa DIN EN 1717 v súlade s národnými alebo regionálnymi predpismi testovať ich funkčnosť (aspoň raz ročne).
- Aby bol zaistený ľahký chod regulačnej jednotky, mal by sa termostat z času čas nastaviť na maximálne horúcu a maximálne studenú vodu.





## 安全技巧

- △ 装配时为避免挤压和切割受伤，必须戴上手套。
- △ 冷热水管间过大的压力差必须予以平衡。

## 安装提示

- 安装前必须检查产品是否受到运输损害。
- 管道和阀门必须根据通用标准进行安装、冲洗和检查。
- 请遵守当地国家现行的安装规定。
- 必须有一扇进口门，用于检修门。  
建议使用无缝钢管连接龙头。

## 技术参数

工作压力:	最大 1 MPa
推荐工作压力:	0,1 - 0,5 MPa
测试压强:	1,6 MPa (1 MPa = 10 bar = 147 PSI)
热水温度:	最大 70°C
推荐热水温度:	65°C
热力消毒:	最大 70°C / 4 分钟
连接管线G 1/2:	左热右冷

该产品专为饮用水设计！

## 符号说明



请勿使用含有乙酸的硅胶！



管道断续器 (参见第页 32)



大小 (参见第页 33)



流量示意图  
(参见第页 33)

时的流速

- ① 出水口 1
- ② 出水口 2



备用零件 (参见第页 35)



检验标记 (参见第页 36)



## 保养



- 单向阀必须在符合国家或当地的法律的情况下按照DIN EN 1717定期检查（至少一年一次）。
- 为了保证恒温器的稳定运转，请务必定期从最热到最冷转动调温器。



安装 (参见第页 31)



## Указания по технике безопасности Описание символов

-  Во время монтажа следует надеть перчатки во избежание прищемления и порезов.
-  донного клапа. Перед установкой смесителя необходимо регулировочными кранами выровнять давление холодной и горячей воды при помощи вентилей регулирующих подачу воды в квартиру.

### Указания по монтажу

- Перед монтажом следует проверить изделие на предмет повреждений при перевозке.
- Трубы и арматура должны быть установлены, промыты и проверены в соответствии с действующими нормами.
- Необходимо соблюдать требования по монтажу, действующие в соответствующих странах.
- Для того, чтобы можно было проверить шланги подключения, необходимо открытие для проверки. Рекомендуется подключать арматуру путем «жесткого соединения труб».

### Технические данные

Рабочее давление: не более. 1 МПа  
 Рекомендуемое рабочее давление: 0,1 - 0,5 МПа  
 Давление: 1,6 МПа  
 (1 МПа = 10 bar = 147 PSI)  
 Температура горячей воды: не более. 70°C  
 Рекомендуемая темп. гор. воды: 65° С  
 Термическая дезинфекция: не более. 70°С / 4 мин  
 Подключение G 1/2: холодная справа - горячая слева

Изделие предназначено исключительно для питьевой воды!

 Не применяйте силикон, содержащий уксусную кислоту.

 Прерыв трубы (см. стр. 32)

 Размеры (см. стр. 33)

 Схем поток (см. стр. 33)

свободное истечение

- ① Выход 1
- ② Выход 2

 Комплект (см. стр. 35)

 Знак технического контроля (см. стр. 36)

 Техническое обслуживание

- Защита обратного тока должна регулярно проверяться (минимум один раз в год) по стандарту DIN EN 1717 или в соответствии с национальными или региональными нормативами
- Для гарантии плавного изменения температуры и долгого срока службы необходимо периодически поворачивать ручку регулировки температуры из положение максимально горячая в положение максимально холодная вода.





## Biztonsági utasítások

- △ A szerelésnél a zúródások és vágási sérülések elkerülése érdekében kesztyűt kell viselni.
- △ A hidegvíz- és a melegvíz-csatlakozások közötti nagy nyomáskülönbséget kikell egyenlíteni!

## Szerelési utasítások

- A szerelés előtt ellenőrizni kell, hogy a terméknek nincs-e szállítási sérülése.
- A vezetékeket és a csaptelepet az érvényes szabványoknak megfelelően kell felszerelni, öblíteni és ellenőrizni
- Az egyes országokban érvényes installációs irányelveket be kell tartani.
- Ahhoz, hogy ellenőrizhessük a csatlakozótömlőket, gondoskodni kell egy átvizsgálónyílásról. Ajánlatos a csaptelepet "szilárd csövezéssel" csatlakoztatni.

## Műszaki adatok

Üzemi nyomás:	max. 1 MPa
Ajánlott üzemi nyomás:	0,1 - 0,5 MPa
Nyomáspróba:	1,6 MPa
	(1 MPa = 10 bar = 147 PSI)
Forróvíz hőmérséklet:	max. 70 °C
Forróvíz javasolt hőmérséklete:	65 °C
Termikus fertőtlenítés:	max. 70 °C / 4 perc
G 1/2 csatlakozás:	hideg jobbra – meleg balra

A terméket kizárólag ivóvízhez tervezték!

## Szimbólumok leírása



Ne használjon ecetsavtartalmú szilikon!



**Csőmegszakító** (lásd a oldalon 32)



**Méretet** (lásd a oldalon 33)



**Átfolyási diagramm**  
(lásd a oldalon 33)

szabad átfolyás

- ① Kifolyó 1
- ② Kifolyó 2



**Tartozékok** (lásd a oldalon 35)



**Vizsgajel** (lásd a oldalon 36)



**Karbantartás**

- A visszafolyásgátlók működése a DIN EN 1717 szabványnak megfelelően, a nemzeti vagy területi rendelkezésekkel összhangban, évente egyszer ellenőrizendő!
- Ahhoz, hogy a szabályozóegység jól működjön, a termosztátot időről időre teljesen megrege és teljesen hidegre kell állítani.





## Turvallisuusohjeet

- △ Asennuksessa on käytettävä käsiineitä puristumien ja viiltojen aiheuttamien tapaturmien estämiseksi.
- △ Suuret paine-erot kylmä- ja kuumavesiliitäntöjen välillä on tasattava.

## Asennusohjeet

- Ennen asennusta on tarkastettava tuotteen mahdolliset kuljetusvahingot.
- Putket ja hana on asennettava, huuhdeltava ja tarkastettava voimassa olevien standardien mukaisesti.
- Jokaisessa maassa on noudatettava siellä päteviä asennusohjeita.
- Liitäntäletkujen tarkastamista varten tarvitaan ehdottomasti tarkastusaukko!  
Suosittelemme kalusteiden asennusta "kiinteällä putkiuksella)

## Tekniset tiedot

Käyttöpaine:	maks. 1 MPa
Suosittelut käyttöpaine:	0,1 - 0,5 MPa
Koestuspaine:	1,6 MPa
	(1 MPa = 10 bar = 147 PSI)
Kuuman veden lämpötila:	maks. 70 °C
Kuuman veden suosituslämpötila:	65 °C
Lämpödesinfektio:	maks. 70 °C / 4 min
Liittimet G 1/2:	kylmä oikealla - kuuma vasemmalla

Tuote on suunniteltu käytettäväksi ainoastaan juomaveden kanssa!

## Merkin kuvaus



Älä käytä etikahappopitoista silikonial



**Putkikatkoin** (katso sivu 32)



**Mitat** (katso sivu 33)



**Virtausdiagrammi**  
(katso sivu 33)

vapaa läpivirtaus

- ① Lähtö 1
- ② Lähtö 2



**Varaosat** (katso sivu 35)



**Koestusmerkki** (katso sivu 36)



**Huolto**

- Vastaventtiilin toiminta on tarkastettava säännöllisesti paikallisten ja kansallisten määräysten mukaisesti (DIN EN 1717, vähintään kerran vuodessa).
- Sääätöyksikön kevytkäyttöisyyden takaamiseksi, säädä säätöyksikkö ajoittain täysin kylmälle ja täysin kuumalle.







## ! Säkerhetsanvisningar

- △ Handskar ska bäras under monteringsarbetet så att man kan undvika kläm- och skärskadorgen werden.
- △ Stora tryckskillnader mellan anslutningarna för varmt och kallt vatten måste utjämnas.

## Monteringsanvisningar

- Det måste undersökas om produkten har transportskador innan den monteras.
- Ledningarna och blandaren måste monteras, spolats igenom och kontrolleras enligt de gällande normerna.
- De installationsriktlinjer som gäller i länderna ska följas.
- Det måste finnas en revisionslucka för att det ska vara möjligt att kontrollera anslutningsslangarna. Vi rekommenderar att blandaren ansluts till en "fast rörledning".

## Tekniska data

Driftstryck:	max. 1 MPa
Rek. driftstryck:	0,1 - 0,5 MPa
Tryck vid provtryckning:	1,6 MPa (1 MPa = 10 bar = 147 PSI)
Varmvattentemperatur:	max. 70 °C
Rek. varmvattentemp.:	65 °C
Termisk desinfektion:	max. 70 °C / 4 min
Anslutningar G 1/2:	kallt höger - varmt vänster

Produkten är enbart avsedd för dricksvatten!

## Symbolförklaring



Använd inte silikon som innehåller ättiksyra!



**Rörventil** (se sidan 32)



**Måtten** (se sidan 33)



**Flödesschema**  
(se sidan 33)

fri genomströmning

- ① Avlopp 1
- ② Avlopp 2



**Reservdelar** (se sidan 35)



**Testsigill** (se sidan 36)





**Skötsel**

- Backventilens funktion måste kontrolleras regelbundet enligt nationella eller regionala bestämmelser i enlighet med DIN EN 1717 (minst en gång per år).
- För att garantera att termostaten ej kalkar igen, ska den regelbundet, en gång per vecka, konditioneras. Det sker genom att man några gånger snabbt slås om temperaturen från hett till kallt och tillbaka.





## Saugumo technikos nurodymai

-  Apsaugai nuo užspaudimo ir įsijovimo montavimo metu mūvėkite pirštines.
-  Turi būti išlyginti šalto ir karšto slėgio nelygumai.

## Montavimo instrukcija

- Prieš montuojant būtina patikrinti, ar gaminys nebuvo pažeistas transportavimo metu.
- Vamzdžiai ir sujungimai turi būti montuojami, plaunami ir tikrinami pagal galiojančias normas.
- Laikykitės atitinkamoje šalyje galiojančių direktyvų dėl įrengimo.
- Kad būtų galima patikrinti jungiamąją žarną, būtina įrengti dureles!  
Rekomenduojama prie maišytuvo jungti vientisus vamzdžius.

## Techniniai duomenys

Darbinis slėgis: ne daugiau kaip 1 MPa  
 Rekomenduojamas slėgis: 0,1 - 0,5 MPa  
 Bandomasis slėgis: 1,6 MPa

(1 MPa = 10 barų = 147 PSI)

Karšto vandens temperatūra: ne daugiau kaip 70°C  
 Rekomenduojama karšto vandens temperatūra: 65°C  
 Terminis dezinfekavimas: ne daugiau kaip 70°C / 4 min  
 Prijungimas G 1/2: Šaltas vanduo dešinėje, karštas - kairėje

Produktas skirtas tik geriamajam vandeniui!

## Simbolio aprašymas



Nenaudokite silikono, kurio sudėtyje yra acto rūgšties!



**Vamzdžio pertraukiklis**  
(žr. psl. 32)



**Išmatavimai** (žr. psl. 33)



**Pralaidumo diagrama**  
(žr. psl. 33)

laisvas vandens pralaidumas

- ① Ištekėjimas 1
- ② Ištekėjimas 2



**Atsarginės dalys** (žr. psl. 35)



**Bandymo pažyma** (žr. psl. 36)



## Techninis aptarnavimas

- Atbulinio vožtuvo apsauga privalo būti tikrinama reguliariai (mažiausiai kartą per metus) pagal DIN EN1717 arba pagal galiojančias nacionalines arba regionines normas.
- Tam, kad būtų garantuotas tolygus temperatūros reguliavimas ir ilgas naudojimas, būtina periodiškai temperatūros rankenėlę pasukti į karščiausios ir šalčiausios temperatūros padėtį.





## Sigurnosne upute

- △ Prilikom montaže se radi sprječavanja prignječenja i posjekotina moraju nositi rukavice.
- △ Velika razlika u pritisku između vruće i hladne vode mora biti izbalansirana.

## Upute za montažu

- Prije montaže mora se provjeriti je li proizvod oštećen prilikom transporta.
- Cijevi i armatura moraju biti postavljeni, isprani i testirani prema važećim normama.
- Obvezno se moraju uvažiti propisi o instalacijama koji vrijede u dotičnoj zemlji.
- Da bi se mogla ispitati ispravnost spojnog crijeva mora postojati otvor za provjeru  
Preporuča se priključiti armaturu "fiksnom instalacijom"

## Tehnički podaci

Najveći dopušteni tlak:	tlak 1 MPa
Preporučeni tlak:	0,1 - 0,5 MPa
Probni tlak:	1,6 MPa (1 MPa = 10 bar = 147 PSI)
Temperatura vruće vode:	tlak 70°C
Preporučena temperatura vruće vode:	65°C
Termička dezinfekcija:	tlak 70°C / 4 min
Spojevi G 1/2:	hladna desno - topla lijevo

Proizvod je koncipiran isključivo za pitku vodu!

## Opis simbola



Nemojte koristiti silikon koji sadrži octenu kiselinu!



**Ventil cijevi** (pogledaj stranicu 32)



**Mjere** (pogledaj stranicu 33)



**Dijagram protoka**  
(pogledaj stranicu 33)

slobodan protok

- ① izlaz 1
- ② izlaz 2



**Rezervni djelovi**  
(pogledaj stranicu 35)



**Oznaka testiranja**  
(pogledaj stranicu 36)



**Održavanje**

- Ispravnost nepovratnog ventila mora se redovito provjeravati prema standardu DIN EN 1717 i u skladu sa važećim propisima (najmanje jednom godišnje).
- Kako bi se olakšala prohodnost i produžio vijek trajanja regulacijske jedinice, potrebno je s vremena na vrijeme podesiti termostat iz položaja maksimalno tople u položaj maksimalno hladne vode.





## ⚠ Güvenlik uyarıları

- ⚠ Montaj esnasında ezilme ve kesilme gibi yaralanmaları önlemek için eldiven kullanılmalıdır.
- ⚠ Sıcak ve soğuk su bağlantıları arasında büyük basınç farklılıkları varsa, bu basınç farklılıklarının dengelenmesi gerekir.

## Montaj açıklamaları

- Montaj işleminden önce ürün nakliye hasarları yönünden kontrol edilmelidir.
- Boruların ve armatürün montajı, yıkanması ve kontrolü geçerli normlara göre yapılmalıdır.
- Ülkelerde geçerli kurulum yönetmeliklerine riayet edilmelidir.
- Bağlantı hortumlarını kontrol etmek için bir revizyon deliği mevcut olmalıdır.  
Bataryanın bir "sabit boru bağlantısına" bağlanması önerilir.

## Teknik bilgiler

İşletme basıncı:	azami 1 MPa
Tavsiye edilen işletme basıncı:	0,1 - 0,5 MPa
Kontrol basıncı:	1,6 MPa
	(1 MPa = 10 bar = 147 PSI)
Sıcak su sıcaklığı:	azami 70 °C
Tavsiye edilen su ısısı:	65 °C
Termik dezenfeksiyon:	azami 70 °C / 4 dak
G 1/2 bağlantılar:	soğuk sağ - sıcak sol

Ürün sadece şebeke suyu için tasarlanmıştır!

## Simge açıklaması



Asetik asit içeren silikon kullanmayın!



**Boru kesici** (bakınız sayfa 32)



**Ölçüleri** (bakınız sayfa 33)



**Akış diyagramı**  
(bakınız sayfa 33)

serbest akış

- ① Çıkış 1
- ② Çıkış 2



**Yedek Parçalar** (bakınız sayfa 35)



**Kontrol işareti** (bakınız sayfa 36)





**Bakım**

- DIN EN 1717 ve ulusal standartlar doğrultusunda Çek valfler düzenli olarak kontrol edilmelidir. ( en az yılda bir kez)
- Ayar ünitesinin kolay hareket etmesini sağlamak için, termostat belirli aralıklarla tamamen sıcak ve soğuk konuma getirilmelidir.





## Instrucțiuni de siguranță

-  La montare utilizați mănuși pentru evitarea contuziunilor și tăierii mâinilor.
-  Diferențele de presiune mari între alimentarea cu apă rece și apă caldă trebuie echilibrate.

## Instrucțiuni de montare

- Înainte de instalare verificați, dacă produsul prezintă deteriorări de transport.
- Conductele și bateriile trebuie montate, spălate și verificate conform normelor în vigoare.
- Respectați reglementările referitoare la instalare valabile în țara respectivă.
- Trebuie prevăzută o deschidere pentru verificarea furtunurilor de conectare!  
Vă recomandăm să racordați bateria la o țeavă fixă.

## Date tehnice

Presiune de funcționare:	max. 1 MPa
Presiune de funcționare recomandată:	0,1 - 0,5 MPa
Presiune de verificare:	1,6 MPa
	(1 MPa = 10 bar = 147 PSI)
Temperatura apei calde:	max. 70°C
Temperatura recomandată a apei calde:	65°C
Dezinfecție termică:	max. 70°C / 4 min
Racorduri G 1/2 :	rece - dreapta / cald - stânga

Produsul este destinat exclusiv pentru apă potabilă.

## Descrierea simbolurilor



Nu utilizați silicon cu conținut de acid acetic!



**Valvă de oprire** (vezi pag. 32)



**Dimensiuni** (vezi pag. 33)



**Diagrama de debit**  
(vezi pag. 33)

debit cu curgere liberă

- ① Evacuare 1
- ② Evacuare 2



**Piese de schimb** (vezi pag. 35)



**Certificat de testare** (vezi pag. 36)



**Întreținere**

- Supapele antiretur trebuie verificate regulat conform DIN EN 1717 și standardele naționale sau regionale (cel puțin o dată pe an).
- Pentru garantarea mișcării ușoare a unității de reglare, vă recomandăm să setați termostatul pe pozițiile limită cald și rece.





## ⚠ Υπ δείξεις σφ λεί ς

- ⚠ Για να αποφύγετε τραυματισμούς κατά τη συναρμολόγηση πρέπει να φοράτε γάντια.
- ⚠ Οι διαφορές της πίεσης μεταξύ της σύνδεσης κρύου και ζεστού νερού θα πρέπει να αντισταθμίζονται.

## Οδηγίες σ ν ρ μ λόγησης

- Πριν τη συναρμολόγηση πρέπει να εξεταστεί το προϊόν για ζημιές μεταφοράς.
- Οι σωλήνες και η μπαταρία πρέπει να τοποθετηθούν σύμφωνα με τα ισχύοντα πρότυπα, να τεθούν υπό πίεση και να δοκιμαστούν.
- Θα πρέπει να τηρούνται οι οδηγίες εγκατάστασης που ισχύουν σε κάθε κράτος.
- Για να μπορείτε να επιθεωρήσετε τους σωλήνες παροχής, θα πρέπει να υφίσταται ένα άνοιγμα επιθεώρησης! Συνιστάται η σύνδεση της βάνας με μία "σταθερή διασωλήνωση".

## Τεχνικά Χ ρ κτηριστικά

Λειτουργία πίεσης:	έως 1 MPa
Συνιστώμενη λειτουργία πίεσης:	0,1 - 0,5 MPa
Πίεση ελέγχου:	1,6 MPa (1 MPa = 10 bar = 147 PSI)
Θερμοκρασία ζεστού νερού:	έως 70 °C
Συνιστώμενη θερμοκρασία ζεστού νερού:	65 °C
Θερμική απολύμανση:	έως 70 °C / 4 min
Συνδέσεις G 1/2:	κρύο δεξιά - ζεστό αριστερά

Το προϊόν έχει σχεδιαστεί αποκλειστικά για πόσιμο νερό!

## Περιγραφή σ μβόλων



Μην χρησιμοποιείτε σιλίκονη που περιέχει οξικό οξύ!



**Δικ πή σωλήν** (βλ. Σελίδα 32)



**Δι στάσεις** (βλ. Σελίδα 33)



**Διάγρ μ μ ρ ής**  
(βλ. Σελίδα 33)

Ελεύθερη ροή

- ① Εξοδος 1
- ② Εξοδος 2



**Αντ λλ κτικά** (βλ. Σελίδα 35)



**Σήμ ελέγχ** (βλ. Σελίδα 36)



**Σ ντήρηση**

- Οι βαλβίδες αντεπιστροφής πρέπει να ελέγχονται τακτικά ως προς τη λειτουργία τους, σύμφωνα με το πρότυπο DIN EN 1717, σε σχέση με τους ισχύοντες εθνικούς ή τοπικούς κανόνες (το ελάχιστο μια φορά το χρόνο) .
- Για να διασφαλίσετε την καλή λειτουργία της μονάδας ρύθμισης, θα πρέπει να ρυθμίζετε το θερμοστάτη από καιρού εις καιρόν σε εντελώς ζεστό ή εντελώς κρύο.





## Varnostna opozorila

- ⚠ Pri montaži je treba nositi rokavice, da se preprečijo poškodbe zaradi zmečkanja ali urezov.
- ⚠ Velike razlike v tlaku med priključkom za mrzlo in priključkom za toplo vodo je potrebno izravnati.

## Navodila za montažo

- Pred montažo je treba izdelek preveriti glede morebitnih transportnih poškodb.
- Cevi in armaturo je treba montirati, izprati in preveriti po veljavnih standardih.
- Upoštevati je treba pravilnike o inštalacijah, ki veljajo v posamezni državi.
- Da bi preverili priključne cevi, mora biti na voljo dostopna odprtina.  
Priporočljivo je, da se armaturo priključi s "trdimi cevmi".

## Tehnični podatki

Delovni tlak:	maks. 1 MPa
Priporočeni delovni tlak:	0,1 - 0,5 MPa
Preskusni tlak:	1,6 MPa (1 MPa = 10 bar = 147 PSI)
Temperatura tople vode:	maks. 70 °C
Priporočena temperatura tople vode:	65 °C
Termična dezinfekcija:	maks. 70 °C / 4 min
Priključki G 1/2:	mrzla desno - topla levo

Proizvod je zasnovan izključno za sanitarno vodo!

## Opis simbola



Ne smete uporabiti silikona, ki vsebuje ocetno kislino!



**Prekinjalnik cevi** (glejte stran 32)



**Mere** (glejte stran 33)



**Diagram pretoka**  
(glejte stran 33)

prost pretok

- ① Odvod 1
- ② Odvod 2



**Rezervni deli** (glejte stran 35)



**Preskusni znak** (glejte stran 36)



**Vzdrževanje**

- Delovanje protipovratnega ventila je potrebno v skladu z DIN EN 1717 in skladno z državnimi in regionalnimi določili redno testirati (najmanj enkrat letno).
- Da bi zagotovili gladko delovanje enote za uravnavanje, je potrebno termostat občasno nastaviti popolnoma na toplo in popolnoma na mrzlo.



**Montaža** (glejte stran 31)



## ⚠ Ohutusjuhised

- ⚠ Kandke paigaldamisel muljumis- ja löikevigastuste vältimiseks kindaid.
- ⚠ Kui külma ja kuumu vee ühenduste surve on väga erinev, tuleb need tasakaalustada.

## Paigaldamisjuhised

- Enne paigaldamist tuleb toodet kontrollida transpordikahjustuste osas
- Voolikute ja segisti paigaldamisel, loputamisel ja kontrollimisel tuleb lähtuda kehtivatest normatiividest
- Vastavas riigis kehtivaid paigalduseeskirju tuleb järgida.
- Ühendusvoolikute kontrollimiseks peab olema eraldi ligipääsuava.  
Soovitame ühendada kraani tugeva torustiku külge.

## Tehnilised andmed

Töörõhk	maks. 1 MPa
Soovitav töörõhk:	0,1 - 0,5 MPa
Kontrollsurve:	1,6 MPa (1 MPa = 10 baari = 147 PSI)
Kuumu vee temperatuur:	maks. 70 °C
Soovitav kuumu vee temperatuur:	65 °C
Termiline desinfektsioon:	maks. 70 °C / 4 min
ühendused G 1/2:	külm paremal, kuum vasakul

Toode on ette nähtud eranditult joogivee jaoks!

## Sümbolite kirjeldus



Ärge kasutage äädikhapet sisaldavat silikooni!



**torukatkesti** (vt lk 32)



**Mõõtude** (vt lk 33)



**Läbivooludiagramm**  
(vt lk 33)

äravoolu surve

- ① väljavool 1
- ② väljavool 2



**Varuosad** (vt lk 35)



**Kontrollsertifikaat** (vt lk 36)



**Hooldus**

- Tagasilöögiklappide toimimist tuleb kooskõlas riiklike ja regionaalsete määrustega regulaarselt kontrollida vastavalt standardile DIN EN 1717 (vähemalt kord aastas).
- Termostaadi hea toimimise tagamiseks on tarvis termostaat keerata aeg-ajalt päris kuumu ja päris külma peale.







## Drošības norādes

- △ Montāžas laikā, lai izvairītos no saspiedumiem un iegriezumiem, nepieciešams nēsāt cimdus.
- △ Jāizlīdzina spiediena atšķirības starp aukstā un karstā ūdens pievadiem.

## Norādījumi montāžai

- Pirms montāžas nepieciešams pārbaudīt, vai produktam transportēšanas laikā nav radušies bojājumi.
- Caurulvadi un armatūra ir jāuzstāda, jāizskalo un jāpārbauda saskaņā ar spēkā esošajiem standartiem.
- Jāievēro attiecīgās valstīs spēkā esošās montāžas prasības.
- Lai varētu pārbaudīt pieslēguma šūtenes, nepieciešama kontrolatvere.  
Ieteikums - jāucējkrānu savienot ar cieta materiāla caurulēm

## Tehniskie dati

Darba spiediens:	maks. 1 MPa
Ieteicamais darba spiediens:	0,1 - 0,5 MPa
Pārbaudes spiediens:	1,6 MPa
	(1 MPa = 10 bar = 147 PSI)
Karstā ūdens temperatūra:	maks. 70 °C
Ieteicamā karstā ūdens temperatūra:	65 °C
Termiskā dezinfekcija :	maks. 70 °C / 4 min
G 1/2 pieslēgumi:	auksta pa labi - karsta pa kreisi

Izstrādājums ir paredzēts tikai dzeramajam ūdenim!

## Simbolu nozīme



Neizmantojot silikonu, kas satur etiķskābi!



**Caurules atdalītājs** (skat. lpp. 32)



**Izmērus** (skat. lpp. 33)



**Caurplūdes diagramma**  
(skat. lpp. 33)

brīva caurplūde

- ① Izteka 1
- ② Izteka 2



**Rezerves daļas** (skat. lpp. 35)



**Pārbaudes zīme** (skat. lpp. 36)



**Apkope**

- Regulāri jāpārbauda pretvārsta funkcija saskaņā ar DIN EN 1717 saistībā ar nacionālajiem vai vietējiem noteikumiem (vismaz vienreiz gadā).
- Lai nodrošinātu regulatora nevainojamu darbību, termostatu laiku pa laikam jāiestata uz maksimāli aukstu un maksimāli karstu ūdeni.



**Montāža** (skat. lpp. 31)



## Sigurnosne napomene

- △ Prilikom montaže se radi sprečavanja prignječenja i posekotina moraju nositi rukavice.
- △ Velika razlika u pritisku između vruće i hladne vode mora biti izbalansirana.

## Instrukcije za montažu

- Pre montaže se mora proveriti da li je proizvod oštećen pri transportu.
- Vodovi i armatura moraju biti postavljeni, isprani i testirani prema važećim normama.
- Treba se pridržavati propisa koji u određenim zemljama važe za instalacije.
- Da bi se mogla ispitati ispravnost priključnih creva, mora postojati otvor za proveru.  
Preporučuje se priključivanje armature "fiksnom instalacijom".

## Tehnički podaci

Radni pritisak:	maks. 1 MPa
Preporučeni radni pritisak:	0,1 - 0,5 MPa
Probni pritisak:	1,6 MPa
	(1 MPa = 10 bar = 147 PSI)
Temperatura vruće vode:	maks. 70 °C
Preporučena temperatura vruće vode:	65 °C
Termička dezinfekcija:	maks. 70 °C / 4 min
Priključci G 1/2:	hladna voda desno - topla leva

Proizvod je koncipiran isključivo za pijaću vodu!

## Opis simbola



Nemojte koristiti silikon koji sadrži sirćetnu kiselinu!



**Element za regulaciju pritiska u cevi vazduhom** (vidi stranu 32)



**Mere** (vidi stranu 33)



**Dijagram protoka** (vidi stranu 33)

slobodan protok

- ① izlaz 1
- ② izlaz 2



**Rezervni delovi** (vidi stranu 35)



**Ispitni znak** (vidi stranu 36)



**Održavanje**

- Ispravno funkcionisanje nepovratnog ventila se mora redovno proveravati prema standardu DIN EN 1717 i u skladu s važećim nacionalnim ili regionalnim propisima (najmanje jednom godišnje).
- Kako bi se olakšala prohodnost i produžio vek trajanja regulacione jedinice, potrebno je s vremena na vreme podesiti termostat na položaje za maksimalno toplu i maksimalno hladnu vodu.





## Sikkerhetshenvisninger

- ⚠ Bruk hansker under montasjen for å unngå klem- og kuttskader.
- ⚠ Store trykkdifferanser mellom kaldt- og varmtvannstilkoblinger skal utlignes.

## Montagehenvisninger

- Før montasjen skal produktet sjekkes for transportskader.
- Ledningene og armaturen skal monteres, spyles og sjekkes iht. de gyldige normer.
- Gjeldende retningslinjer for rørleggerarbeid i de enkelte land skal følges.
- For å kunne sjekke koblingslangene må en revisjonsåpning være tilstede.  
Det anbefales å koble armaturen til en fast installert rørledning.

## Tekniske data

Driftstrykk	maks. 1 MPa
Anbefalt driftstrykk:	0,1 - 0,5 MPa
Prøvetrykk	1,6 MPa
	(1 MPa = 10 bar = 147 PSI)
Varmtvannstemperatur	maks. 70 °C
Anbefalt temperatur for varmt vann	65 ° C
Termisk desinfisering:	maks. 70 °C / 4 min
Tilkoblinger G 1/2	kaldt høyre - varm venstre

Produktet er utelukkende designet for drikkevann!

## Symbolbeskrivelse



Ikke bruk silikon som inneholder eddiksyre!



**Rørvavbryter** (se side 32)



**Mål** (se side 33)



**Gjennomstrømningsdiagram**  
(se side 33)

fri gjennomstrømning

- ① Utgang 1
- ② Utgang 2



**Service-deler** (se side 35)



**Prøvemerket** (se side 36)



**Vedlikehold**

- Funksjonen til returløpssperren skal iht. DIN EN 1717 og i samsvar med de nasjonale og lokale forskrifter sjekkes regelmessig (minst en gang i året).
- For å holde regulerings-enheten bevegelig, skal termostaten stilles fra tid til annen på helt varmt og helt kaldt.



**Montasje** (se side 31)



## Ук з ния з безоп сност

- △ При монтажа трябва да се носят ръкавици, за да се избегнат наранявания поради притискане или порязване.
- △ Големите разлики в налягането между изводите за студената и топлата вода трябва да се изравняват.

## Ук з ния з монт ж

- Преди монтажа продуктът трябва да се провери за транспортни щети.
- Тръбопроводите и арматурата трябва да се монтират, промият и проверят в съответствие с валидните норми.
- Трябва да бъдат спазвани валидните в съответните страни предписания за инсталиране.
- Необходимо е наличието на ревизионен отвор, за да могат да се проверяват свързващите маркучи. Препоръчва се, арматурата да се свърже със „здрава тръбопроводна система“.

## Технически д нни

Работно налягане:	макс. 1 МПа
Препоръчително работно налягане:	0,1 - 0,5 МПа
Контролно налягане:	1,6 МПа
	(1 МПа = 10 bar = 147 PSI)
Температура на горещата вода:	макс. 70°C
Препоръчителна температура на горещата вода:	65°C
Термична дезинфекция:	макс. 70°C / 4 мин
Изводи G 1/2:	студено отлясно – топло отляво

Продуктът е разработен само за питейна вода!

## Опис ние н символите



Не използвайте силикон, съдържащ оцветна киселина!



**Тръбен прекъсв ч** (вижте стр. 32)



**Р змери** (вижте стр. 33)



**Ди гр м н поток**  
(вижте стр. 33)

свободен поток

- ① Извод 1
- ② Извод 2



**Сервизни ч сти** (вижте стр. 35)



**Контролен зн к** (вижте стр. 36)



## Поддръжк

- Съгласно DIN EN 1717 функционирането на приспособленията за предотвратяване на обратния поток трябва редовно да се проверява в съответствие с националните или регионални изисквания (поне веднъж годишно).
- За да се гарантира лекоподвижността на регулиращото звено, от време на време термостатът трябва да се поставя на максимално топло и на максимално студено.





## Udhëzime sigurie

- ⚠ Për të evituar lëndimet e pickimeve ose të prerjeve gjatë procesit të montimit duhet që të vishni doreza.
- ⚠ Ndryshimet e mëdha të presionit mes lidhjeve të ujit të ftohtë dhe atij të ngrohtë duhen ekuilibruar.

## Udhëzime për montimin

- Përpara montimit duhet që produkti të kontrollohet për dëmtime nga transporti.
- Tubacionet dhe rubinetet duhet që të montohen, të shpëlahen dhe të kontrollohen sipas standardeve në fuqi
- Duhet të respektohen linjat udhëzuese të instalimit, të vlefshme për vendet respektive.
- Për të kontrolluar tubacionet e lidhjeve duhet paraparë një hapësirë për revizion.  
Rekomandohet montimi i armaturës me "tubacion permanent".

## Të dhëna teknike

Presioni gjatë punës	maks. 1 MPa
Presioni i rekomanduar:	0,1 - 0,5 MPa
Presioni për provë:	1,6 MPa
	(1 MPa = 10 bar = 147 PSI)
Temperatura e ujit të ngrohtë	maks. 70 °C
Temperatura e rekomanduar e ujit të ngrohtë:	65 °C
Dezinfektim Termik:	maks. 70 °C / 4 min
Lidhjet G 1/2:	i ftohtë djathtas - i ngrohtë majtas

Produkti është projektuar ekskluzivisht për ujë të pijshëm!

## Përshkrimi i simbolit



Mos përdorni silikon që në përbërje ka acid acetik.



**Ndërprerës i tubit** (shih faqen 32)



**Përmasat** (shih faqen 33)



**Diagrami i qarkullimit**  
(shih faqen 33)

rrijdhja e lirë

- ① Zbrazja 1
- ② Zbrazja 2



**Pjesët e servisit** (shih faqen 35)



**Shenja e kontrollit** (shih faqen 36)



**Mirëmbajtja**

- Penguesit e rrijdhjes në drejtim të kundërt duhen kontrolluar rregullisht në bazë të normave DIN EN 1717 konform normave nacionale dhe regjionale (së paku një herë në vit).
- Për të lehtësuar përdorimin e njësisë rregulluese, termostati do të duhet çuar herë pas here nga shumë i ngrohtë në shumë të ftohtë.





## وصف الرمز

هام! لا تستخدم السليكون الذي يحتوي على أمضاض!



قاطع الماسورة (راجع صفحة 32)



أبعاد (راجع صفحة 33)



رسم للصراف  
(راجع صفحة 33)



التدفق الحر

- ① مخرج 1
- ② مخرج 2

قطع الغيار (راجع صفحة 35)



شهادة اختبار (راجع صفحة 36)



الصيانة



- يجب فحص صمام عدم الرجوع بصفة منتظمة حسب المواصفة DIN EN 1717 وذلك طبقاً للوائح الوطنية أو الإقليمية (مرة واحد سنوياً على الأقل).
- لضمان التشغيل السلس للترموستات، من الضروري تحويله من وقت إلى آخر من أقصى سخونة إلى أقصى البرودة.

## تنبيهات الأمان ⚠

يجب إرتداء قفازات لليد أثناء التركيب لتجنب حدوث أخطار الإنحشار أو الجروح.

يجب أن يكون تيار الماء الساخن والماء البارد متعادلين في الضغط.

### تعليمات التركيب

- قبل القيام بعملية التركيب، يجب فحص المنتج للتأكد من خلوه من أية تلفيات ناتجة عن النقل.
- يجب تركيب وغسيل واختبار التوصيلات وخلطات المياه طبقاً للمعايير السارية.
- يجب مراعاة القواعد الخاصة بالتركيب وأعمال السباكة وفقاً للوائح الخاصة بكل بلد.
- يجب وجود منفذ للدخول من أجل أعمال الإصلاح الصيانة لخرائط التوصيل.
- من المستحسن توصيل الصنوبر بمواسير "صلبة".

### المواصفات الفنية

- ضغط التشغيل: الحد الأقصى 1 ميجاباسكال
- ضغط التشغيل الموصى به: 0,1 - 0,5 ميجاباسكال
- ضغط الاختبار: 1,6 ميجاباسكال
- (1 ميجاباسكال = 10 بار = 147 PSI)
- درجة حرارة الماء الساخن: الحد الأقصى 70°C
- درجة الحرارة الموصى بها للماء الساخن: 65°C
- تعقيم حراري: الحد الأقصى 70°C / 4 الدقيقة
- الوصلات G 1/2: الماء البارد جهة اليمين - الماء الساخن جهة اليسار

المنتج مخصص فقط لماء الشرب!



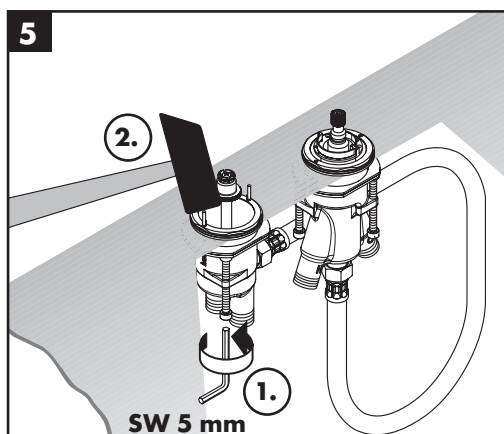
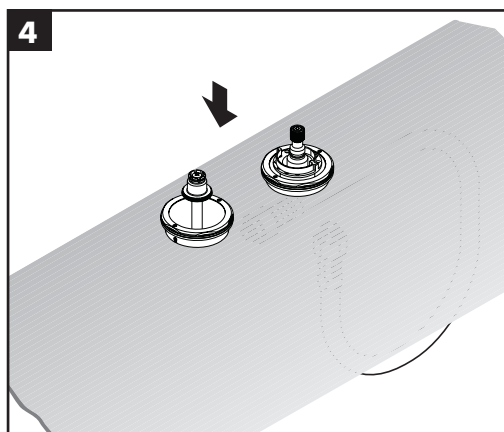
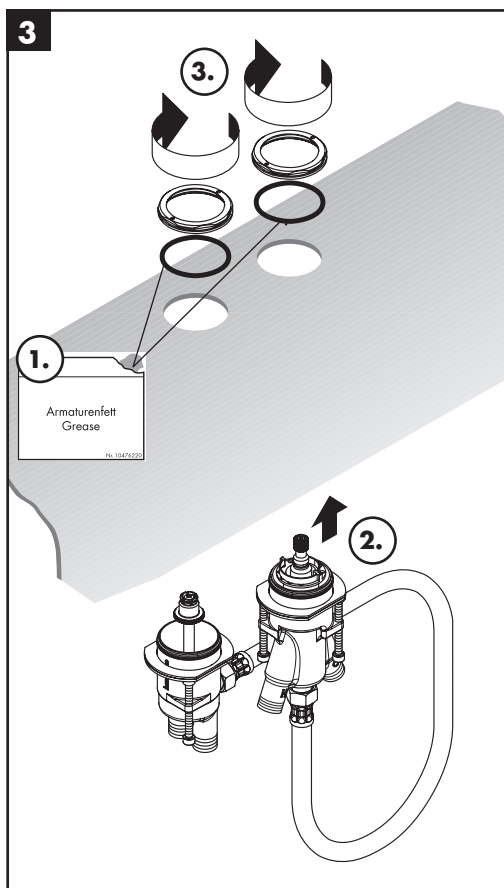
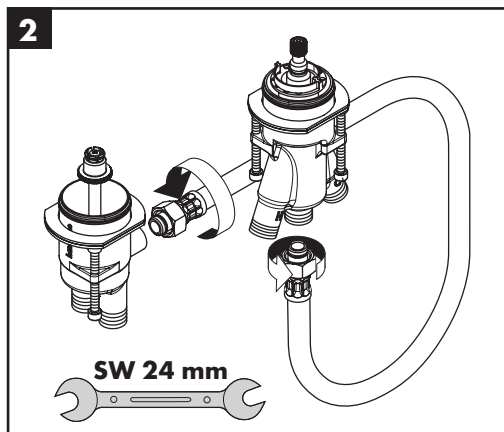
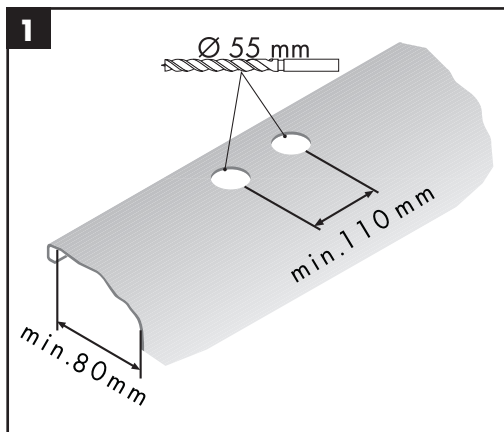



6a

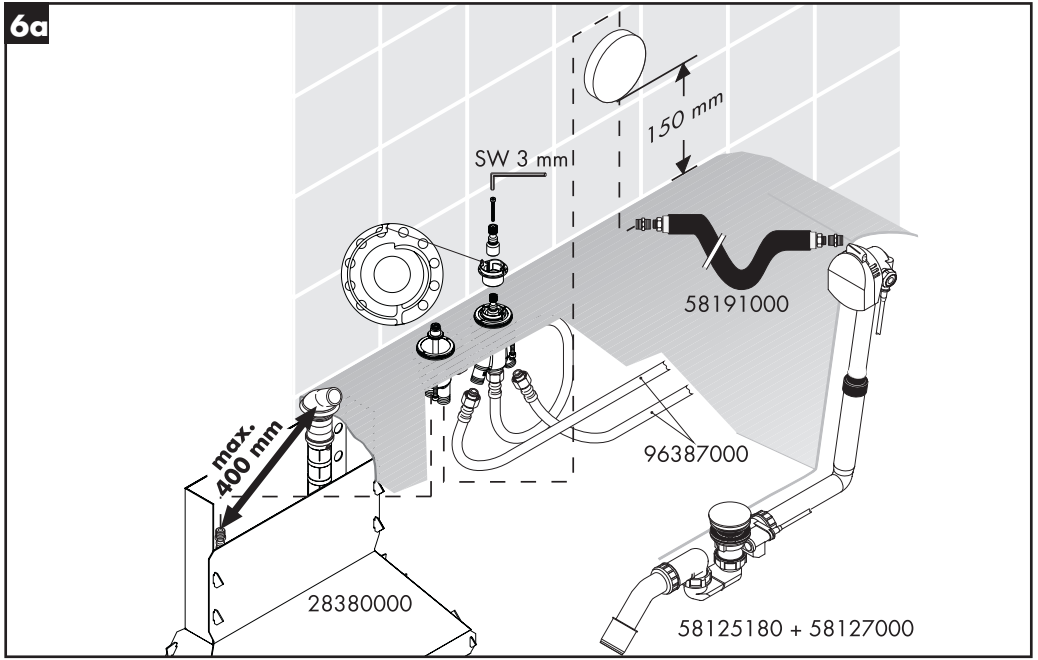

6b

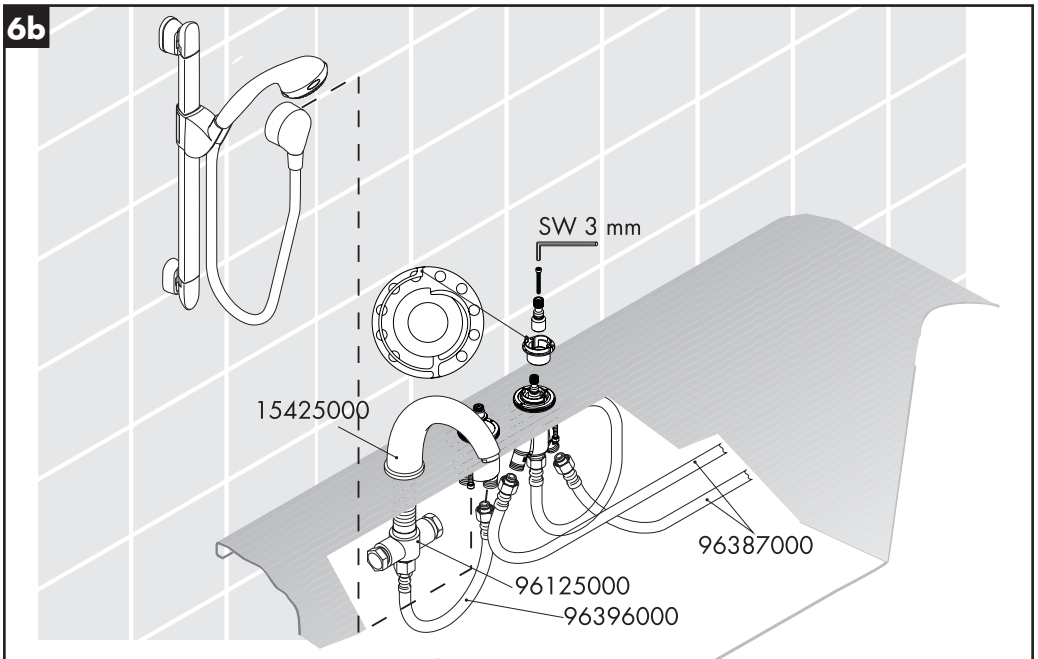



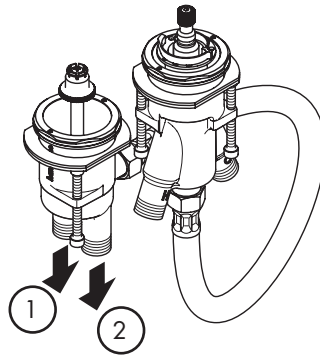
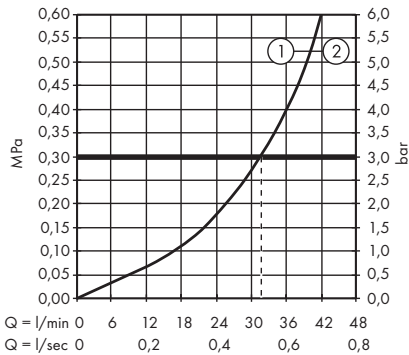
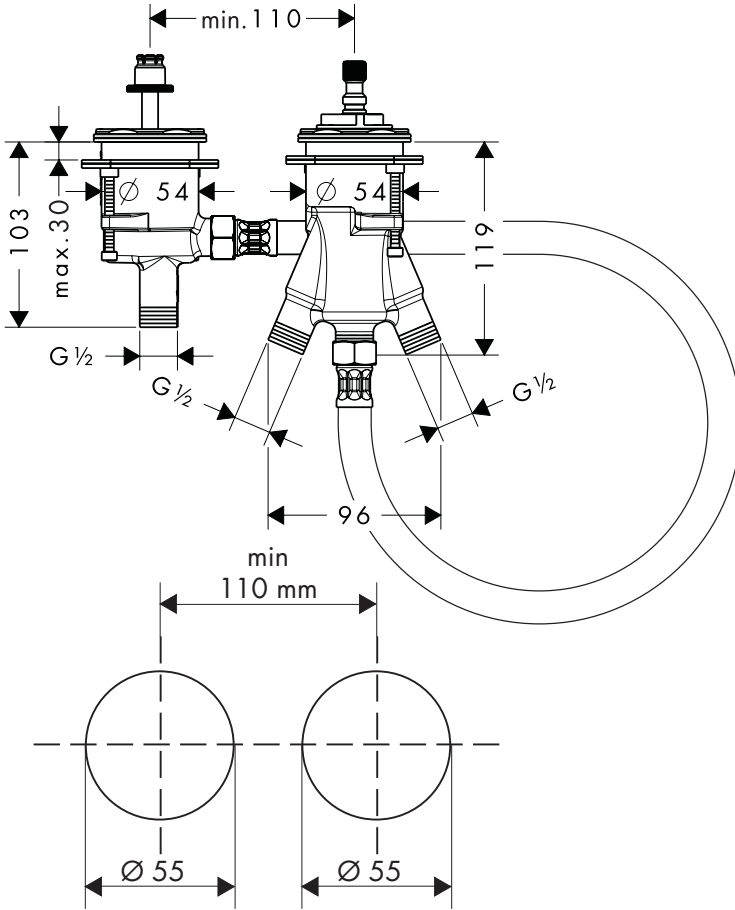
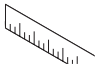

**Starck**

10480000

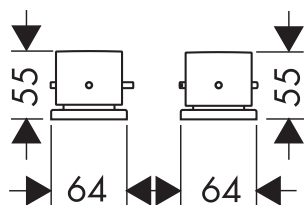
**Starck Organic**

12422000

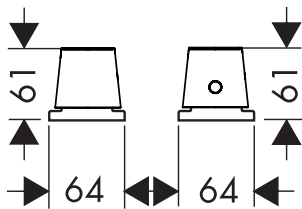
**Massaud**

18480000

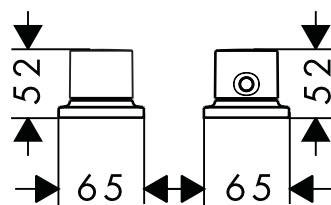
**Bouroullec**

19432000

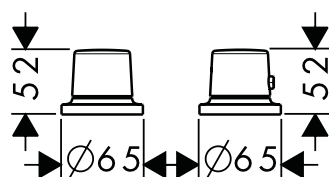
**Citterio E**

36412000

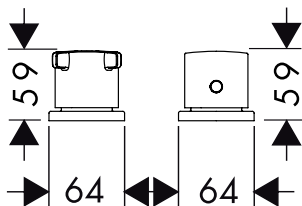
**Uno**

38480000

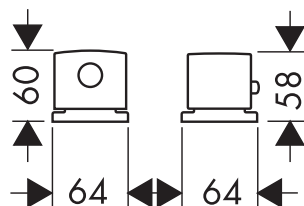
**Citterio**

39480000

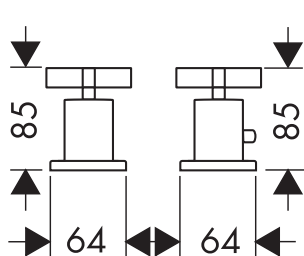
**Citterio**

39482000

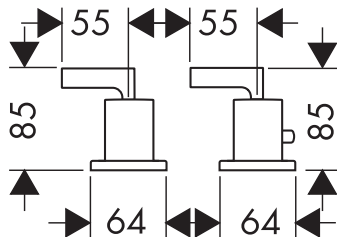
**PuraVida**

15474000 / 15474400

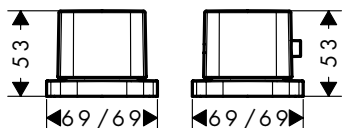

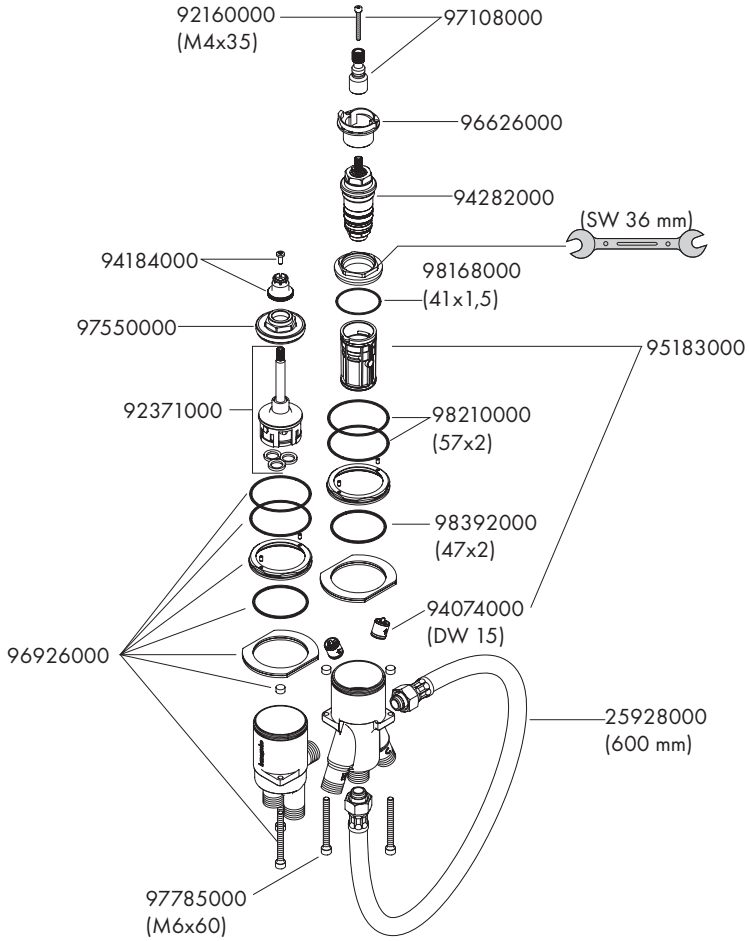



**P-IX**

**DVGW SVGW ACS WRAS**

**ETA**



**GODKENDT  
TIL DRIKKEVAND KIWA**

**1355018X**

X X

