



ENGLISH FRANÇAIS DEUTSCH NEDERLANDS  
ITALIANO PORTUGUÊS ESPAÑOL ΕΛΛΗΝΙΚΗ



# Getting Started 1

## Démarrage 1

## Inbetriebnahme 1

## Aan de Slag-gids 1

## Guida Rapida 1

## Para Começar 1

## Guía de inicio 1

## Ξεκινώντας 1



Video Tutorials  
Didacticiels vidéo  
Videolernprogramme  
Videozelfstudies

Tutorial video  
Tutoriais em Vídeo  
Tutoriales en vídeo  
Βίντεο με οδηγίες

<http://canon.com/ijsetup>



RMC (Regulatory Model Code): K10437  
RMC (Regulatory Model Code): K10436  
RMC (Regulatory Model Code): K10435

# 1

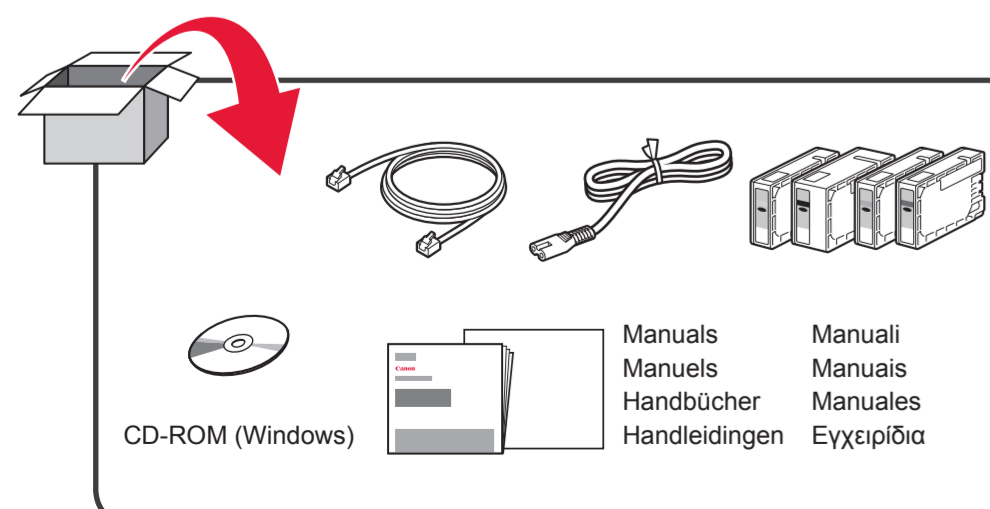

Manuals  
Manuels  
Handbücher  
Handleidingen

Manuali  
Manuais  
Manuales  
Εγχειρίδια

# 2

**1** Remove the tape and packing materials from outside the printer.  
Retirez la bande ainsi que les matériaux d'emballage de l'imprimante.  
Entfernen Sie das Klebeband und das Verpackungsmaterial außen am Drucker.  
Verwijder de tape en het verpakkingsmateriaal van de buitenkant van de printer.  
Rimuovere il nastro e il materiale di imballaggio dall'esterno della stampante.  
Remova a fita e os materiais de embalagem da parte externa da impressora.  
Retire la cinta y los materiales de protección del exterior de la impresora.  
Αφαιρέστε την ταινία και τη συσκευασία από τον εκτυπωτή.

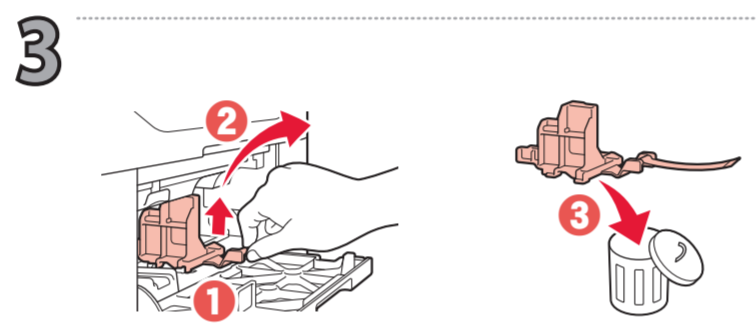
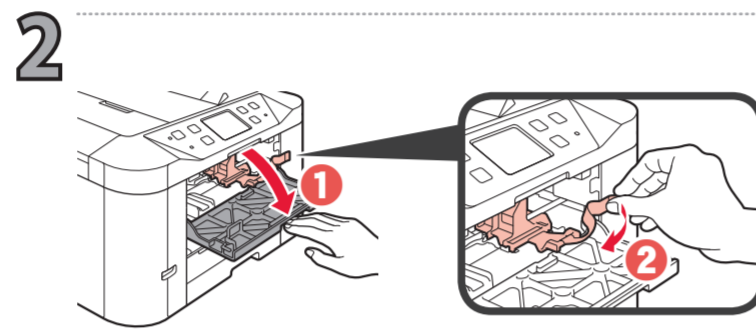

# 3

**1**

Back	Retro
Arrière	Parte traseira
Rückseite	Parte posterior
Achterkant	Πίσω μέρος

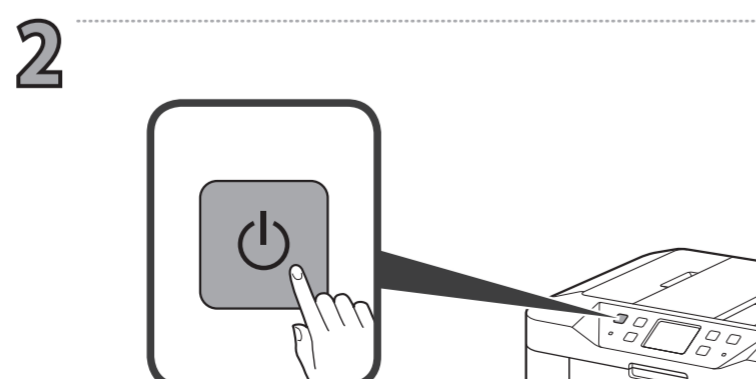
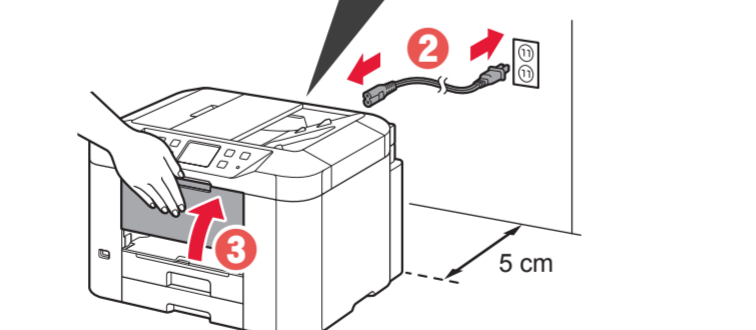
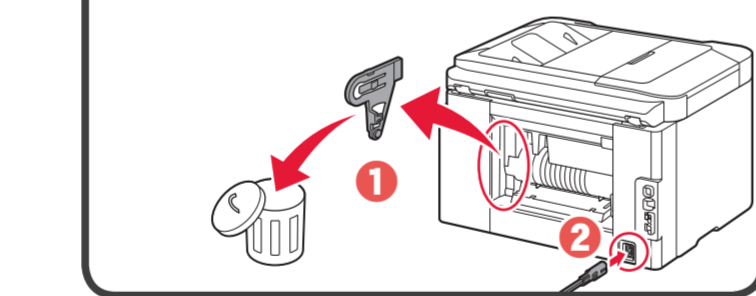

# 3

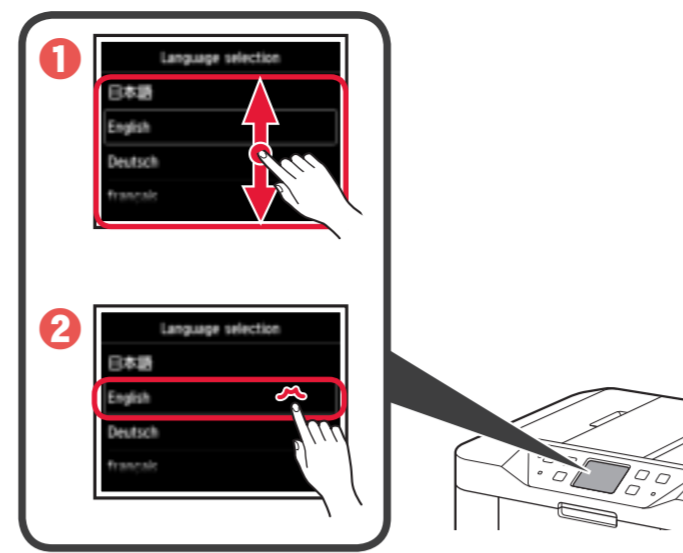

**4** If the screens below appear, select your country or region.  
Si les écrans ci-dessous s'affichent, sélectionnez votre pays ou votre région.  
Wenn die folgenden Bildschirme angezeigt werden, wählen Sie Ihr Land oder Ihre Region aus.  
Selecteer uw land of regio wanneer de onderstaande schermen worden weergegeven.  
Se appare la schermata riportata di seguito, selezionare il paese o la regione.  
Se as telas abaixo aparecerem, selecione seu país ou região.  
Si aparecen las siguientes pantallas, seleccione su país o región.  
Αν εμφανιστούν οι ακόλουθες οθόνες, επιλέξτε τη χώρα ή την περιοχή σας.



**5**

**1** For development and marketing of products that better meet customer needs, Canon requests that information related to your Canon product be sent to Canon through this internet.

**2** Read the descriptions in the supplied "Safety and Important Information" and select whether you agree to send information.

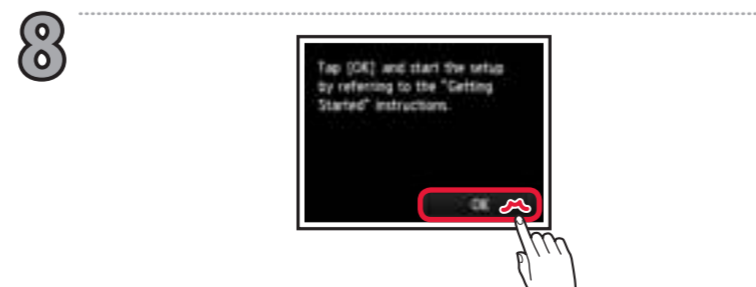
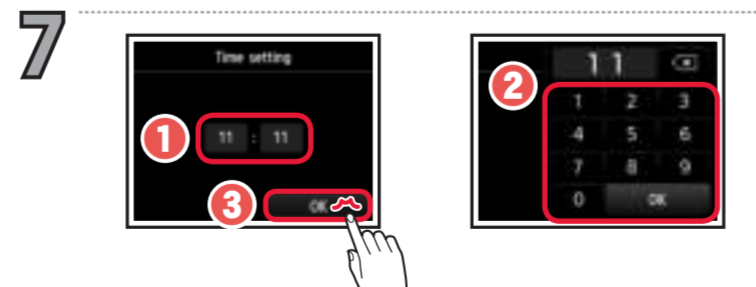
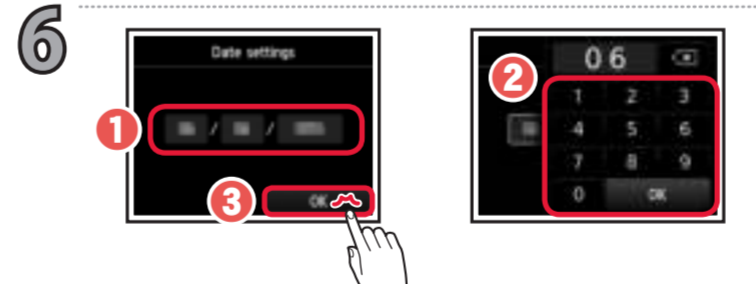

# 4

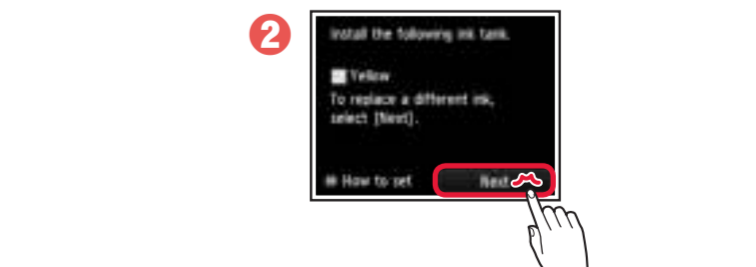
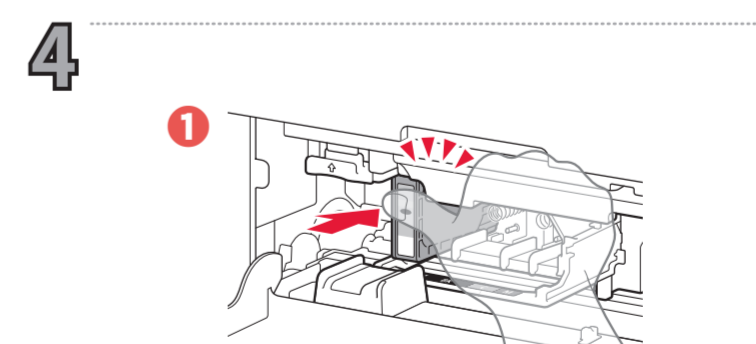
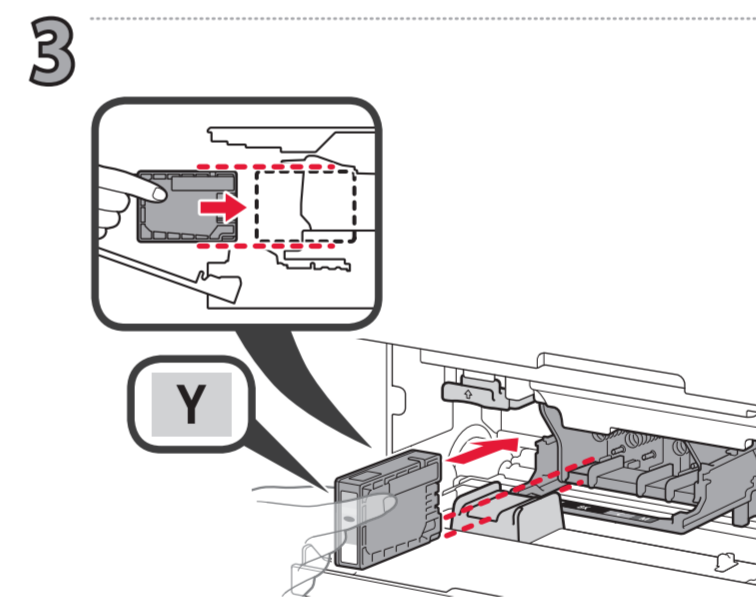
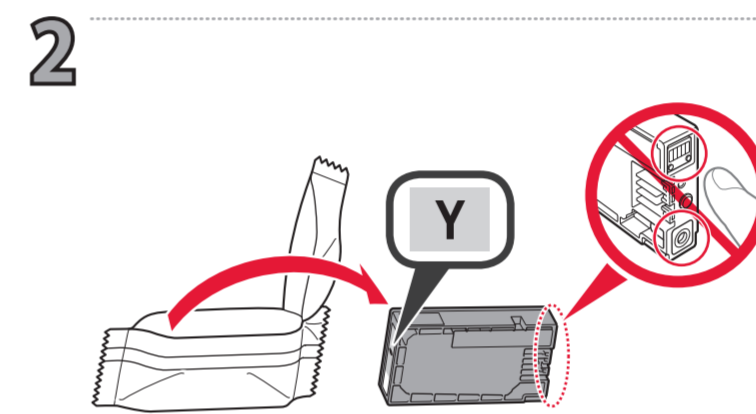
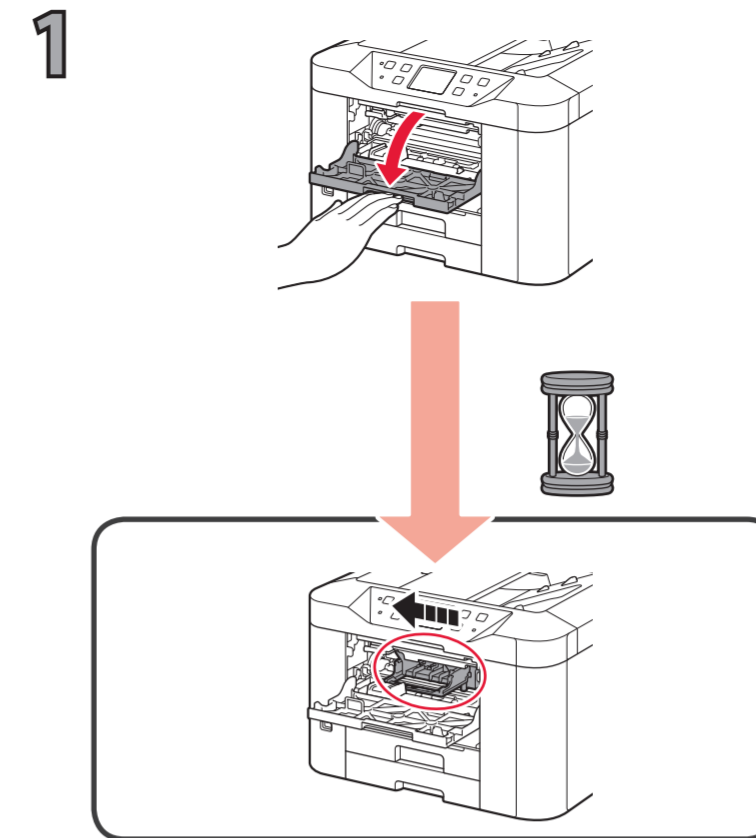

# 5

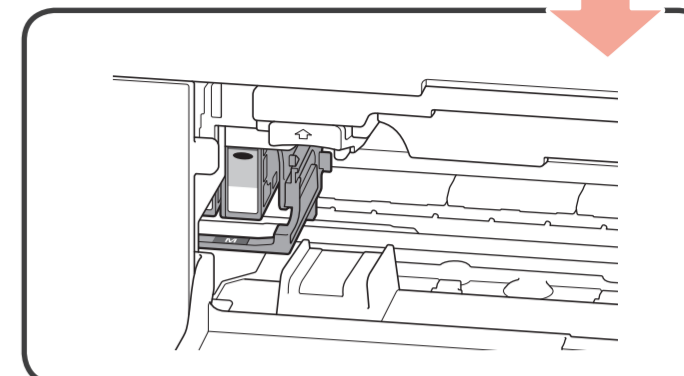
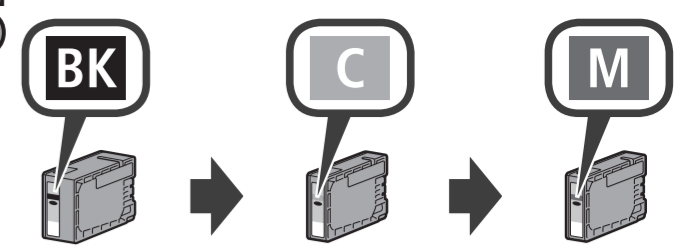

An installed ink tank cannot be removed until the message to replace it is displayed.

Une cartouche d'encre installée ne peut pas être retirée tant que le message demandant son remplacement n'est pas affiché.

Ein eingesetzter Tintenbehälter kann erst entfernt werden, wenn die entsprechende Meldung zu dessen Austausch angezeigt wird.

Een geïnstalleerde inkttank kan pas worden verwijderd wanneer het bericht over vervanging wordt weergegeven.

Un serbatoio d'inchiostro installato non può essere rimosso finché non viene visualizzato il messaggio che indica di sostituirlo.

Um cartucho de tinta instalado não poderá ser removido antes da exibição da mensagem para substituí-lo.

Un depósito de tinta instalado no se puede retirar hasta que aparece el mensaje para retirarlo.

Δεν μπορείτε να αφαιρέσετε ένα τοποθετημένο δοχείο μελάνης μέχρι να εμφανιστεί στην οθόνη το μήνυμα αντικατάστασης.

# 6



# 5

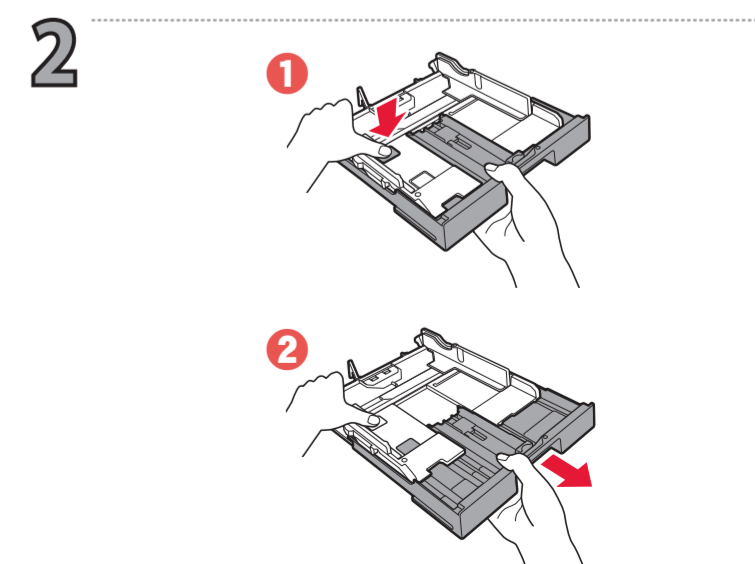
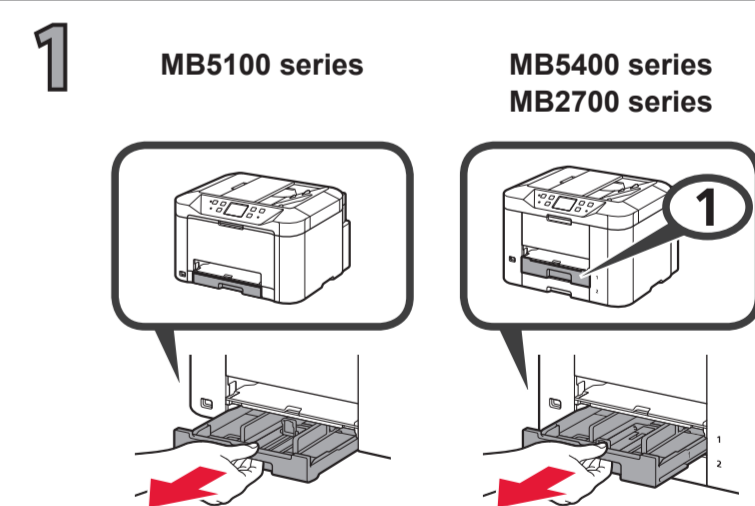

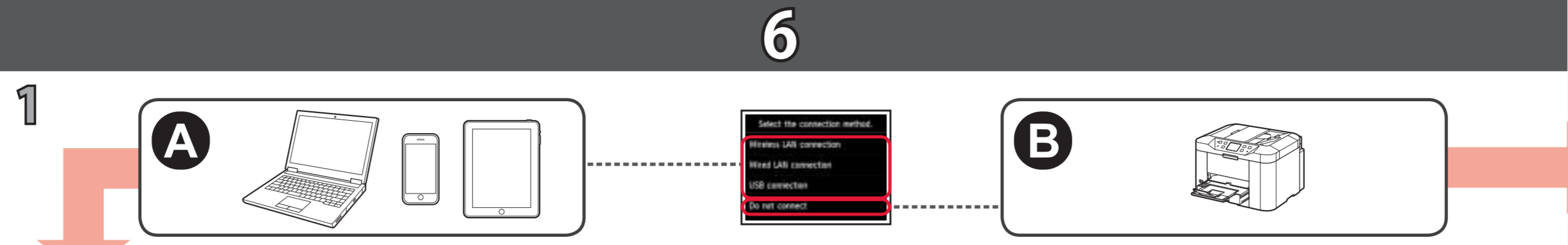
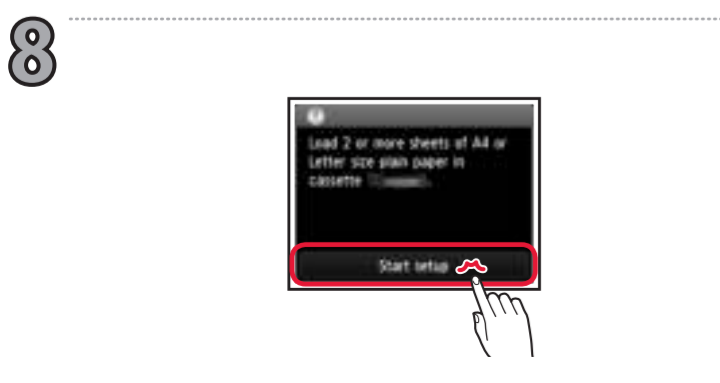
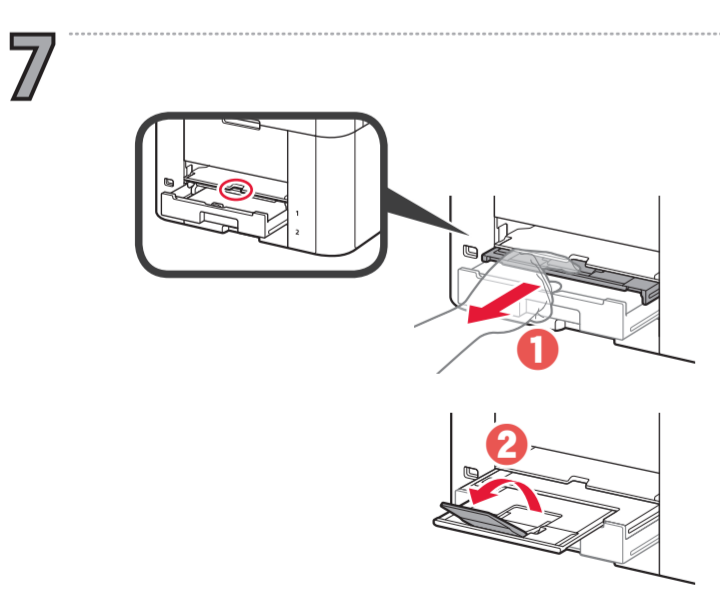
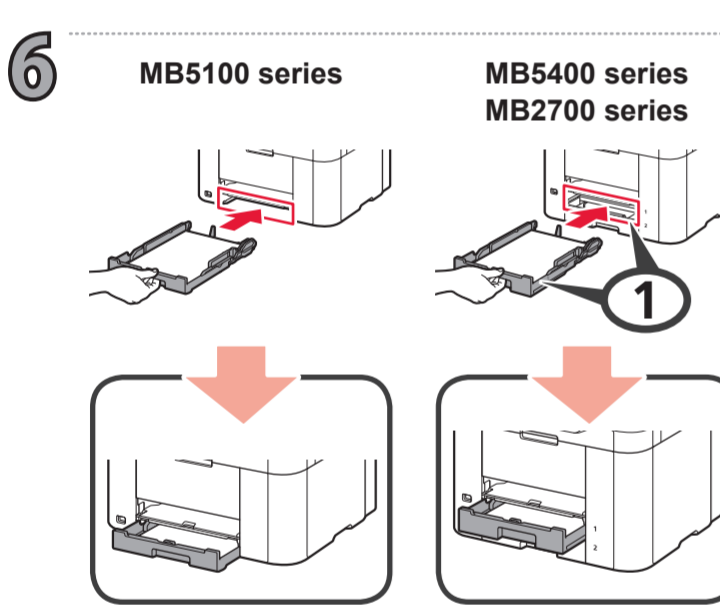
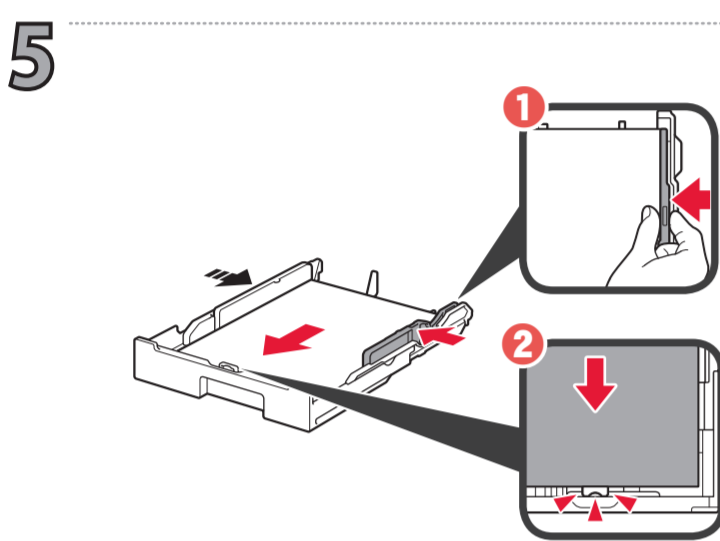
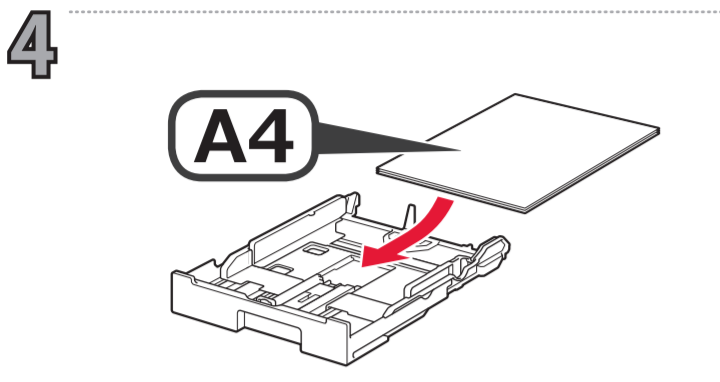
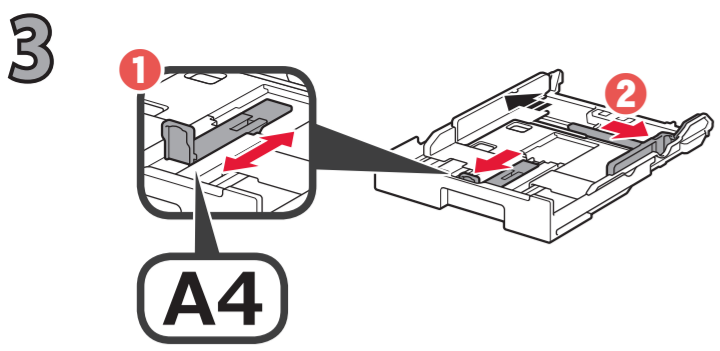

Connection method	Metodo di connessione
Méthode de connexion	Método de conexão
Verbindungsmethode	Método de conexión
Verbindungsmethode	Μέθοδος σύνδεσης

<p>Wireless LAN Réseau sans fil WLAN Draadloos LAN LAN wireless LAN Sem-fio LAN inalámbrica Ασύρματο LAN</p>	<p>Wired LAN Réseau câblé Drahtgebundenes LAN Bedraad LAN LAN wired LAN com fio LAN cableada Ενσύρματο LAN</p>
<p>USB</p>	

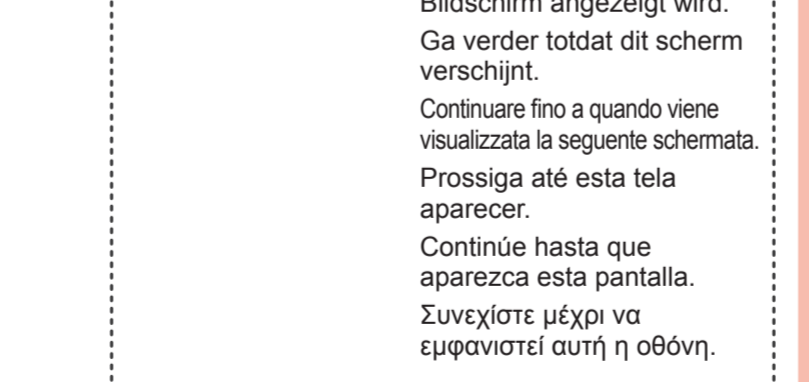
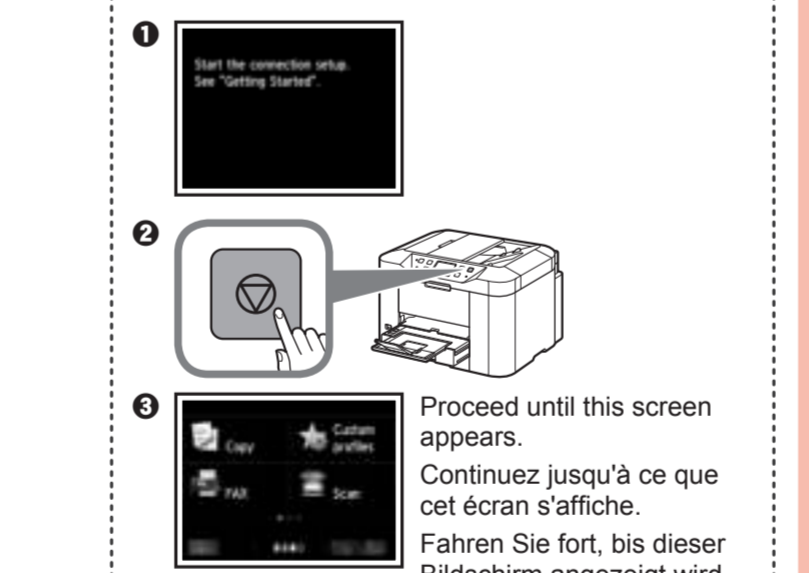
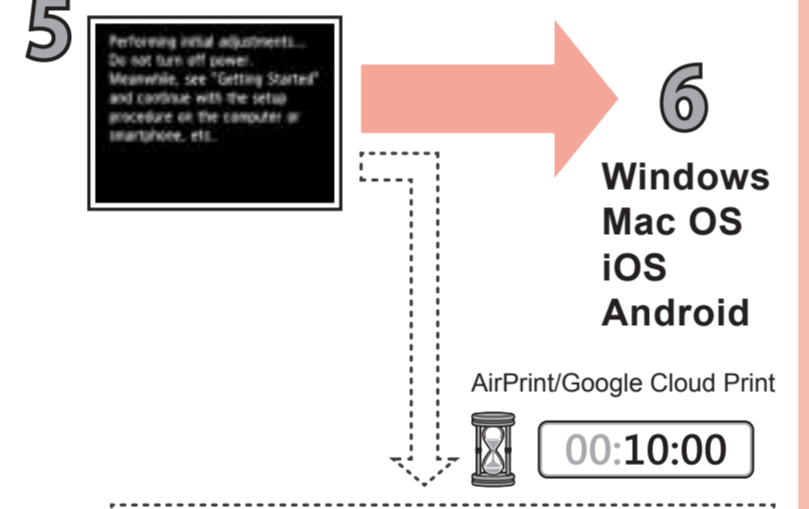
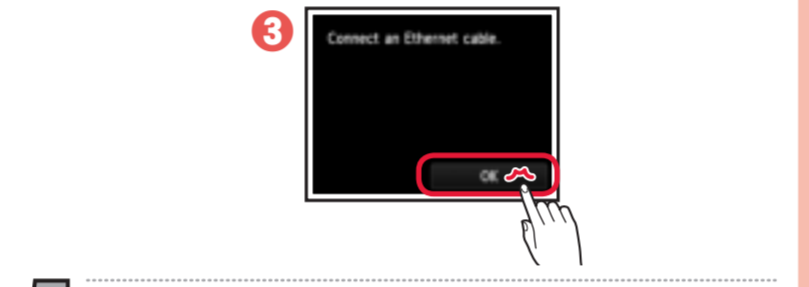
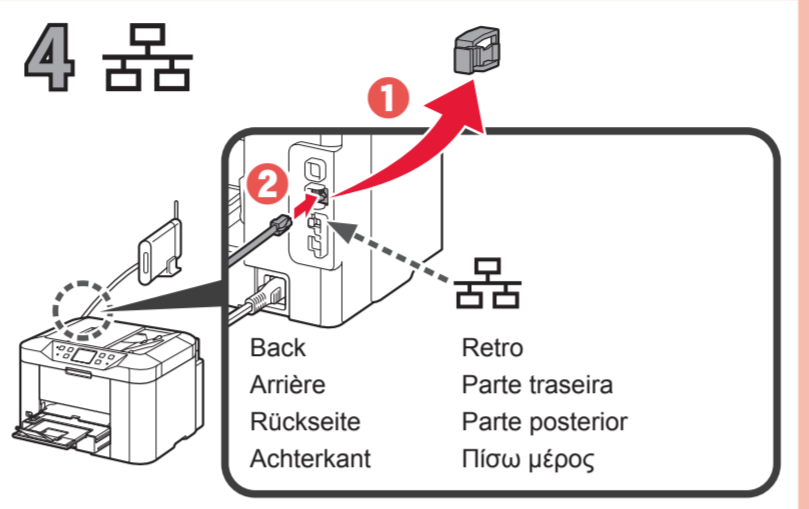
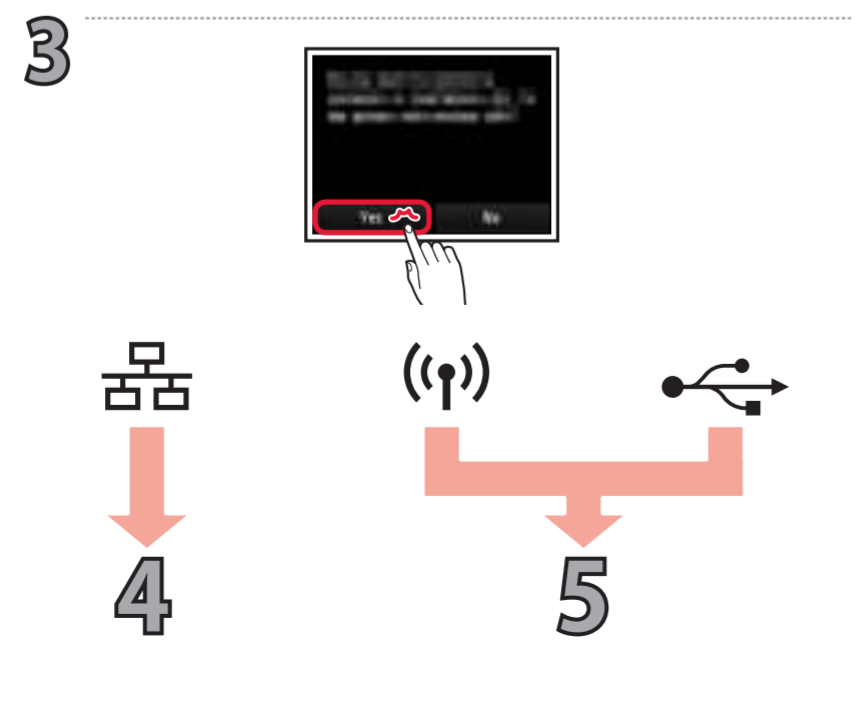

**6** Follow the steps in the **Getting Started 2** to make connections and install software, and then continue the printer setup.  
 Suivez les étapes du document **Démarrage 2** pour procéder aux connexions et installer le logiciel, puis continuez la configuration de l'imprimante.  
 Befolgen Sie die Anweisungen unter **Inbetriebnahme 2**, um die Verbindungen herzustellen und die Software zu installieren, und fahren Sie dann mit der Einrichtung des Druckers fort.  
 Volg de stappen in de **Aan de Slag-gids 2** om verbinding te maken en software te installeren en ga daarna verder met de installatie van de printer.  
 Attenersi ai passaggi descritti nella **Guida Rapida 2** per effettuare le connessioni e installare il software, quindi continuare l'impostazione della stampante.  
 Siga as etapas em **Para Começar 2** para fazer conexões e instalar o software e então prossiga com a configuração da impressora.  
 Siga los pasos de la **Guía de inicio 2** para realizar las conexiones e instalar el software y después continúe con la configuración de la impresora.  
 Για συνδέσεις και για εγκατάσταση λογισμικού, ακολουθήστε τα βήματα στο **Ξεκινώντας 2** και, έπειτα, συνεχίστε τη ρύθμιση του εκτυπωτή.

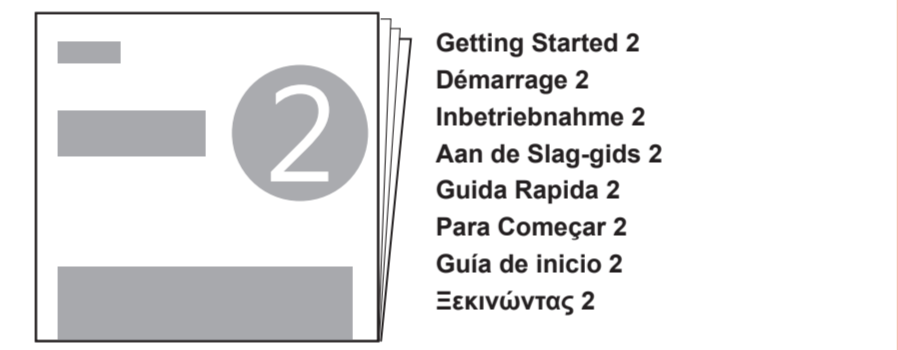

**How to set up the FAX**  
**Configuration du FAX**  
**Anweisungen zum Einrichten des FAX**  
**De fax instellen**  
**Guida alla configurazione del FAX**  
**Como configurar o FAX**  
**Cómo configurar el FAX**  
**Ρύθμιση του FAX**

<http://canon.com/ijsetup>

Installed Basic Manual  
 Manuel de base installé  
 Installiertes Basishandbuch  
 Geïnstalleerde Basis Handleiding  
 Installato Manuale di base  
 Manual Básico Instalado  
 Manual básico instalado  
 Το Εγχειρίδιο Βασικών Λειτουργιών έχει εγκατασταθεί

**B**

**2**

**1** Select the connection method.  
 Wireless LAN connection  
 Wired LAN connection  
 USB connection  
 Do not connect

**2** Connection will not be set up, OK?  
 Yes No

**3**

Adjusting...  
 About 10 minutes

00:10:00

The printer is set up and ready for use.  
 L'imprimante est configurée et prête à l'utilisation.  
 Der Drucker ist eingerichtet und zur Verwendung bereit.  
 De printer is ingesteld en gereed voor gebruik.  
 La stampante è configurata e pronta per l'uso.  
 A impressora é configurada e está pronta para uso.  
 La impresora se ha configurado y está lista para su uso.  
 Ο εκτυπωτής έχει ρυθμιστεί και είναι έτοιμος για χρήση.

**?**

The **Online Manual** is accessible from the website.  
 Le **Manuel en ligne** est accessible à partir du site Web.  
 Das **Online-Handbuch** finden Sie auf der Website.  
 De **Online handleiding** is toegankelijk via de website.  
 È possibile accedere al **Manuale online** dal sito Web.  
 O **Manual On-line** pode ser acessado do site.  
 Se puede acceder al **Manual en línea** desde el sitio web.  
 Το **Εγχειρίδιο Online** διατίθεται στη διαδικτυακή τοποθεσία.

<http://canon.com/ijsetup>

Windows PC