



■ Report No.: DDT-R21062936-1E02

■ Issued Date: Oct. 28, 2021

CE EMC TEST REPORT

FOR

Applicant	:	Harman International Industries, Inc.
Address	:	8500 Balboa Boulevard, Northridge, CA 91329, UNITED STATES
Equipment under Test	:	Gaming Wireless Headset / USB Wireless Dongle
Model No.	:	QUANTUM610 / QUANTUM610TM
Trade Mark	:	JBL
Manufacturer	:	Harman International Industries, Inc.
Address	:	8500 Balboa Boulevard, Northridge, CA 91329, UNITED STATES

Issued By: Dongguan Dongdian Testing Service Co., Ltd.

Add.: No. 17, Zongbu Road 2, Songshan Lake Sci&Tech, Industry Park,
Dongguan City, Guangdong Province, China, 523808

Tel.: +86-0769-38826678, **E-mail:** ddt@dgddt.com, **http://**www.dgddt.com

REPORT

Table of Contents

	Test report declares	5
1.	Summary of Test Results	7
2.	General Test Information	8
2.1.	Description of EUT	8
2.2.	Primary function of EUT	8
2.3.	Port of EUT	9
2.4.	Accessories of EUT	9
2.5.	Block diagram EUT configuration for test	9
2.6.	Decision of final test mode	10
2.7.	Deviations of test standard	10
2.8.	Test environment conditions	10
2.9.	Test laboratory	11
2.10.	Measurement uncertainty	12
3.	Conducted Emission Test Report (mains power port)	13
3.1.	Test equipment	13
3.2.	Block diagram of test setup	13
3.3.	Limits	14
3.4.	Assistant equipment used for test	14
3.5.	Test procedure	15
3.6.	Test result	15
3.7.	Test photo	20
4.	Radiated Emissions Test	22
4.1.	Test equipment	22
4.2.	Block diagram of test setup	23
4.3.	Limits	25
4.4.	Assistant equipment used for test	26
4.5.	Test procedure	26
4.6.	Test result	26
4.7.	Test photo	43
5.	Harmonic Current and Voltage Fluctuations& Flicker Test Report	47
5.1.	Test equipment	47
5.2.	Block diagram of test setup	47
5.3.	Harmonic current limits	47
5.4.	Voltage fluctuations & flicker Limit	48
5.5.	Assistant equipment used for test	48
5.6.	Test procedure	49

5.7.	Test result	49
5.8.	Test photo	52
6.	Electrostatic Discharge Test Report	53
6.1.	Test equipment	53
6.2.	Block diagram of test setup	53
6.3.	Test levels and performance criterion	53
6.4.	Assistant equipment used for test	54
6.5.	Test procedure.....	54
6.6.	Test result	55
6.7.	Test photo	56
7.	Continuous Radio Frequency Disturbances.....	58
7.1.	Test equipment	58
7.2.	Block diagram of test setup	59
7.3.	Test levels and performance criterion	59
7.4.	Assistant equipment used for test	60
7.5.	Test procedure.....	60
7.6.	Test result	61
7.7.	Test photo	63
8.	Electrical Fast Transients (EFT) Test Report.....	65
8.1.	Test equipment	65
8.2.	Block diagram of test setup	65
8.3.	Test levels and performance criterion	66
8.4.	Assistant equipment used for test	66
8.5.	Test procedure.....	66
8.6.	Test result	67
8.7.	Test photo	67
9.	Surges test report	69
9.1.	Test equipment	69
9.2.	Block diagram of test setup	69
9.3.	Test levels and performance criterion	69
9.4.	Assistant equipment used for test	70
9.5.	Test procedure.....	70
9.6.	Test result	71
9.7.	Test photo	72
10.	Continuous Conducted Disturbances.....	73
10.1.	Test equipment	73
10.2.	Block diagram of test setup	73
10.3.	Test levels and performance criterion	74

10.4.	Assistant equipment used for test	75
10.5.	Test procedure.....	75
10.6.	Test result	76
10.7.	Test photo	77
11.	Power-Frequency Magnetic Fields.....	79
11.1.	Test equipment	79
11.2.	Block diagram of test setup	79
11.3.	Test levels and performance criterion	79
11.4.	Assistant equipment used for test	79
11.5.	Test procedure.....	80
11.6.	Test result	80
11.7.	Test photo	81
12.	Voltage Dips and Interruptions	82
12.1.	Test Equipment.....	82
12.2.	Block diagram of test setup	82
12.3.	Test levels and performance criterion	82
12.4.	Assistant equipment used for test	82
12.5.	Test Procedure	83
12.6.	Test result	83
12.7.	Test photo	84
13.	Photos of the EUT	85

Test Report Declare

Applicant	:	Harman International Industries, Inc.
Address	:	8500 Balboa Boulevard, Northridge, CA 91329, UNITED STATES
Equipment under Test	:	Gaming Wireless Headset / USB Wireless Dongle
Model No.	:	QUANTUM610 / QUANTUM610TM
Trade Mark	:	JBL
Manufacturer	:	Harman International Industries, Inc.
Address	:	8500 Balboa Boulevard, Northridge, CA 91329, UNITED STATES

Test Standard Used:

EN 55032:2015, EN 55032:2015/A11:2020, EN 55035:2017, EN 55035:2017/A11:2020, EN IEC 61000-3-2:2019, EN 61000-3-3:2013/A1:2019

We Declare:

The equipment described above is tested by Dongguan Dongdian Testing Service Co., Ltd. and in the configuration tested the equipment complied with the standards specified above. The test results are contained in this test report and Dongguan Dongdian Testing Service Co., Ltd. is assumed of full responsibility for the accuracy and completeness of these tests.

After test and evaluation, our opinion is that the equipment in accordance with above standards about the electromagnetic compatibility requirements of EMC Directive 2014/30EU.

Report No.:	DDT-R21062936-1E02		
Date of Receipt:	Aug. 20, 2021	Date of Test:	Aug. 20, 2021 ~ Oct. 28, 2021



Prepared By:

Jerry Xue/Engineer

Approved By:



Damon Hu/EMC Manager

Note: This report applies to above tested sample only. This report shall not be reproduced in parts without written approval of Dongguan Dongdian Testing Service Co., Ltd.

Revision History

Rev.	Revisions	Issue Date	Revised By
---	Initial issue	Oct. 28, 2021	

1. Summary of Test Results

EMISSION (EMI)		
Description of Test Item	Standard	Result
Conducted disturbance at mains terminals	EN 55032:2015, EN 55032:2015/A11:2020	PASS
Asymmetric mode conducted emissions	EN 55032:2015, EN 55032:2015/A11:2020	N/A
Conducted differential voltage emissions	EN 55032:2015, EN 55032:2015/A11:2020	N/A
Radiated disturbance	EN 55032:2015, EN 55032:2015/A11:2020	PASS
Harmonic current emissions	EN IEC 61000-3-2:2019	N/A
Voltage fluctuations & flicker	EN 61000-3-3:2013/A1:2019	PASS
IMMUNITY (EMS)		
Description of Test Item	Standard	Results
Electrostatic discharge (ESD)	EN 55035:2017, EN 55035:2017/A11:2020	PASS
Continuous radio frequency disturbances	EN 55035:2017, EN 55035:2017/A11:2020	PASS
Electrical fast transients (EFT)	EN 55035:2017, EN 55035:2017/A11:2020	PASS
Surges	EN 55035:2017, EN 55035:2017/A11:2020	PASS
Continuous conducted disturbances	EN 55035:2017, EN 55035:2017/A11:2020	PASS
Power-frequency magnetic fields	EN 55035:2017, EN 55035:2017/A11:2020	PASS
Voltage dips and interruptions	EN 55035:2017, EN 55035:2017/A11:2020	PASS
Note: N/A is an abbreviation for Not Applicable, and means this item is not applicable for this device.		

Note: 1. The EMI measurements had been made in the operating mode producing the largest emission in the frequency band being investigated consistent with normal applications. An attempt had been made to maximize the emission by varying the configuration of the EUT.

2. The EMS measurements had been made in the frequency bands being investigated, with the EUT in the most susceptible operating mode consistent with normal applications. The configuration of the test sample had been varied to achieve maximum susceptibility.

2. General Test Information

2.1. Description of EUT

EUT* Name	: Gaming Wireless Headset / USB Wireless Dongle
Model Number	: QUANTUM610 / QUANTUM610TM
EUT Function Description	: Please reference user manual of this device
Power Supply	: DC 5V from external AC Adapter : DC 3.7V Polymer Li-ion built-in battery
EUT Class (Only For EMI)	: Class B
Maximum Work Frequency	: 2480MHz
Sample Type	: Series production
Sample Number	: S21062936-01

Note 1: EUT is the abbreviation of equipment under test.

Note 2: “☑” means to be chosen or applicable; “☐” means don't to be chosen or not applicable; This note applies to entire report.

Note 3: Equipment meeting Class A requirements may not offer adequate protection to broadcast services within a residential environment; The Class B requirements for equipment are intended to offer adequate protection to broadcast services within the residential environment. Equipment compliant with the class A requirements of standard EN 55032 should have a warning notice in the user manual stating that it could cause radio interference. For example, Warning: Operation of this equipment in a residential environment could cause radio interference.

Note 4: The accessories of this product are Type-C cables and aux in cables, and the length of other signal cables and control cables used during the test is less than 3 meters.

2.2. Primary function of EUT

Function	Description
<input type="checkbox"/> Broadcast reception function	N/A
<input type="checkbox"/> Print	N/A
<input type="checkbox"/> Scan	N/A
<input type="checkbox"/> Display and display output	N/A
<input type="checkbox"/> Musical tone generating	N/A
<input type="checkbox"/> Networking	N/A
<input checked="" type="checkbox"/> Audio output	On-era devices
<input type="checkbox"/> Telephony	N/A
<input checked="" type="checkbox"/> Bluetooth	Bluetooth
<input checked="" type="checkbox"/> Other:	N/A

2.3. Port of EUT

Port	Description
<input checked="" type="checkbox"/> AC mains power port	Powered by AC/DC power converter
<input type="checkbox"/> DC network power port	N/A
<input type="checkbox"/> Wired network port	N/A
<input type="checkbox"/> Signal data/control port	N/A
<input type="checkbox"/> Antenna port	N/A
<input checked="" type="checkbox"/> Audio input port	Aux in port
<input type="checkbox"/> Video input port	N/A
<input type="checkbox"/> Audio output port	N/A
<input type="checkbox"/> Video output port	N/A
<input type="checkbox"/> Other:	N/A

2.4. Accessories of EUT

Description of Accessories	Manufacturer	Model number	Description	Remark
USB Cable	Harman	N/A	Length: 1.50m	N/A
Aux in Cable	Harman	N/A	Length: 1.30m	N/A

2.5. Block diagram EUT configuration for test

For mode 1: Charging mode

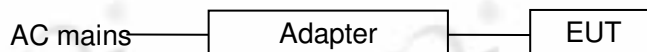

For mode 2: Charging + Aux in mode



For mode 3: Aux in mode

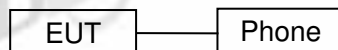

For mode 4: Standby mode



Test mode description: phone playing 1 kHz sine audio signal and input to EUT. Adjust the volume phone make to EUT radiated the highest emissions.

2.6. Decision of final test mode

Emission	Conducted Disturbance at AC mains Terminals	Mode 1: Charging mode Mode 2: Charging + Aux in mode
	Radiated emission	Mode 1: Charging mode Mode 2: Charging + Aux in mode Mode 3: Aux in mode Mode 4: Standby mode
	Voltage fluctuations & flicker	Mode 1: Charging mode Mode 2: Charging + Aux in mode
Immunity	Electrostatic discharge	Mode 1: Charging mode Mode 2: Charging + Aux in mode Mode 3: Aux in mode Mode 4: Standby mode
	Continuous radio frequency disturbances	Mode 1: Charging mode Mode 2: Charging + Aux in mode Mode 3: Aux in mode Mode 4: Standby mode
	Electrical fast transients	Mode 1: Charging mode Mode 2: Charging + Aux in mode
	Surges	Mode 1: Charging mode Mode 2: Charging + Aux in mode
	Continuous conducted disturbances	Mode 1: Charging mode Mode 2: Charging + Aux in mode
	Power-frequency magnetic fields	Mode 1: Charging mode Mode 2: Charging + Aux in mode Mode 3: Aux in mode Mode 4: Standby mode
	Voltage dips and interruptions	Mode 1: Charging mode Mode 2: Charging + Aux in mode

2.7. Deviations of test standard

No deviation.

2.8. Test environment conditions

During the measurement the environmental conditions were within the listed ranges:

Temperature range:	20-25°C
Humidity range:	40-75%
Pressure range:	86-106 kPa

Note: The specific temperature and humidity information of each test item refers to the temperature and humidity record in the corresponding test data.

2.9. Test laboratory

Dongguan Dongdian Testing Service Co., Ltd.

Add.: No. 17, Zongbu Road 2, Songshan Lake Sci&Tech, Industry Park, Dongguan City, Guangdong Province, China, 523808.

Tel.: +86-0769-38826678, <http://www.dgddt.com>, Email: ddt@dgddt.com.

CNAS Accreditation No. L6451; A2LA Accreditation Number: 3870.01

FCC Designation Number: CN1182, Test Firm Registration Number: 540522

Innovation, Science and Economic Development Canada Site Registration Number: 10288A

Conformity Assessment Body identifier: CN0048

VCCI facility registration number: C-20087, T-20088, R-20123, G-20118

2.10. Measurement uncertainty

Test Item	Uncertainty
Conducted disturbance at mains terminals	3.32 dB (150 kHz-30 MHz)
Uncertainty for telecommunication port conduction emission test	AAN with aLCL = 55 ... 40 dBc: 3.64 dB AAN with aLCL = 65 ... 50 dBc: 4.08 dB AAN with aLCL = 75 ... 60 dBc: 4.56 dB
Uncertainty for 3M radiation emission test (30 MHz-1 GHz)	4.70 dB (Antenna Polarize: V) 4.84 dB (Antenna Polarize: H)
Uncertainty for 10M radiation emission test (30 MHz-1 GHz)	4.48 dB (Antenna Polarize: V) 4.64 dB (Antenna Polarize: H)
Uncertainty for radiation disturbance test (1 GHz to 6 GHz)	4.10 dB (1-6 GHz)
Uncertainty for Flicker test	0.2%
Uncertainty for Harmonic test	5%
Uncertainty for Electrostatic discharge	Rise time: 4% Peak current: 3.1% Current at 30 ns: 3.1% Current at 60 ns: 3.1%
Uncertainty for Surge	Peak of the open-circuit voltage impulse: 3% Front time of the open-circuit voltage impulse: 5% Width of the open-circuit voltage impulse: 5% Peak of the short-circuit current impulse: 2.7% Front time of the short-circuit current impulse: 5% Duration of the short-circuit current impulse: 3%
Uncertainty for Electrical fast transients	Voltage rise time: 3.7% Peak voltage value: 3.4% Voltage pulse width: 3.7%
Uncertainty for Continuous conducted disturbances	0.25dB
Uncertainty for Continuous radio frequency disturbances	1.12dB
Uncertainty for Power-frequency magnetic fields	10%
Uncertainty for Voltage dips and interruptions	3.7%
Temperature	0.4 °C
Humidity	2%
Note: This uncertainty represents an expanded uncertainty expressed at approximately the 95% confidence level using a coverage factor of k=2.	

3. Conducted Emission Test Report (mains power port)

3.1. Test equipment

Equipment	Manufacturer	Model No.	Serial No.	Last Cal.	Cal. Interval
<input checked="" type="checkbox"/> 1# Conducted emission					
Test Receiver	R&S	ESCI	100551	Sep. 02, 2021	1 Year
LISN 1	R&S	ENV216	101109	Sep. 07, 2021	1 Year
LISN 2	R&S	ESH2-Z5	100309	Sep. 07, 2021	1 Year
Pulse Limiter	R&S	ESH3-Z2	101242	Sep. 02, 2021	1 Year
CE Cable 1	HUBSER	N/A	W10.01	Sep. 02, 2021	1 Year
LISN 3	SCHWARZBECK	NSLK 8163	00017	Sep. 02, 2021	1 Year
Test software	Audix	E3	V 6.11111b	N/A	N/A
<input type="checkbox"/> 2# Conducted emission					
Test Receiver	R&S	ESCI	101028	Sep. 02, 2021	1 Year
LISN 1	R&S	ENV216	101170	Sep. 07, 2021	1 Year
Pulse Limiter	R&S	KH43101	4310118015 68-12#	Jun. 01, 2021	1 Year
CE Cable 2	HUBSER	N/A	W11.02	Jun. 01, 2021	1 Year
Test software	Audix	E3	V 6.11111b	N/A	N/A

3.2. Block diagram of test setup

For table-top equipment

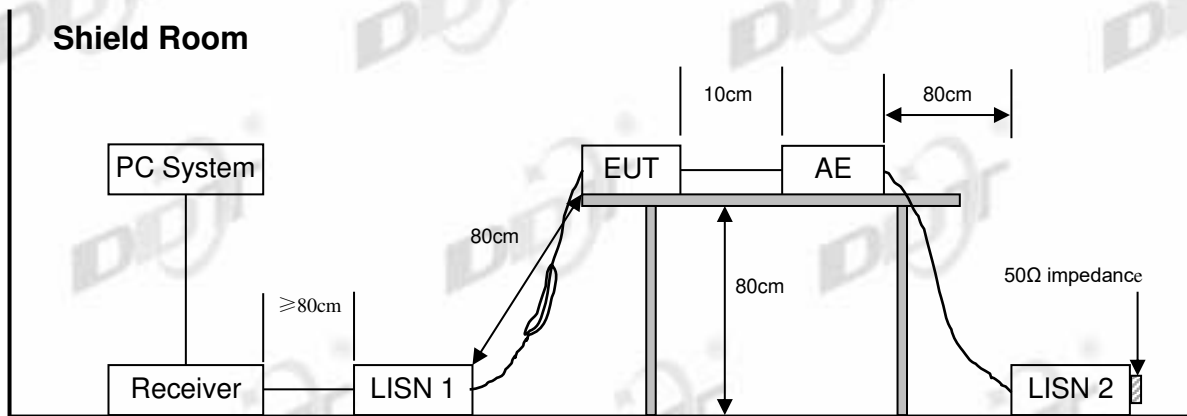

For floor standing equipment

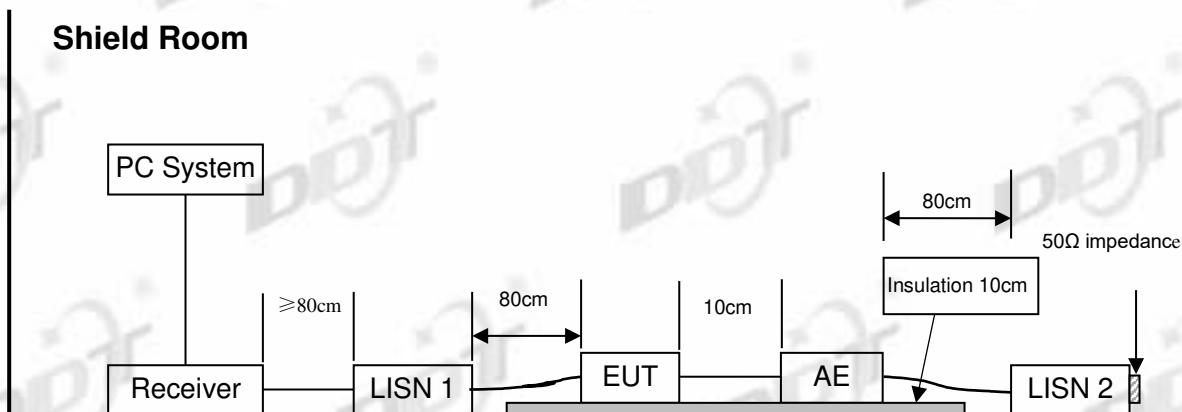

For combinations equipment

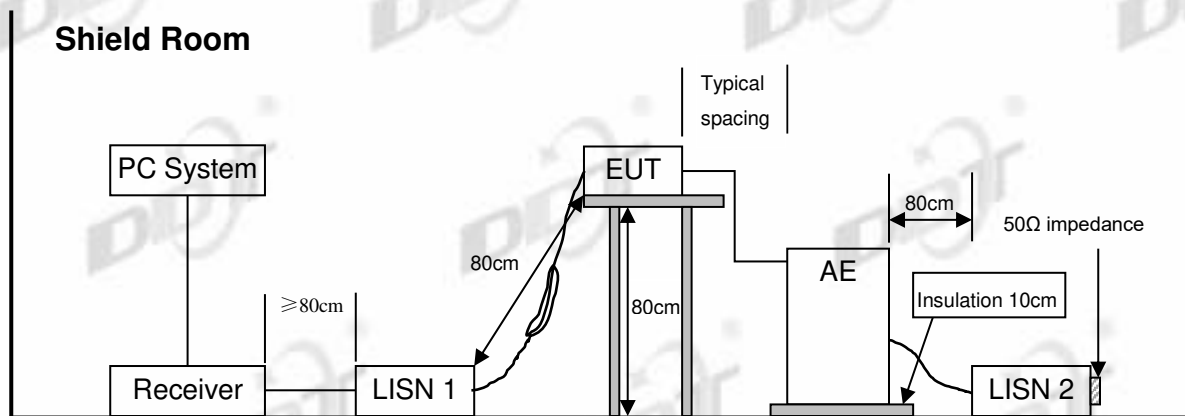

3.3. Limits

Class A

Frequency	Quasi-Peak Level dB(μ V)	Average Level dB(μ V)
150 kHz ~ 500 kHz	79	66
500 kHz ~ 30 MHz	73	60

Class B

Frequency	Quasi-Peak Level dB(μ V)	Average Level dB(μ V)
150 kHz ~ 500 kHz	66 ~ 56*	56 ~ 46*
500 kHz ~ 5 MHz	56	46
5 MHz ~ 30 MHz	60	50

Notes: 1. * Decreasing linearly with logarithm of frequency.

2. The lower limit shall apply at the transition frequencies.

3.4. Assistant equipment used for test

Assistant equipment	Manufacturer	Model number	Description	other
Adapter	SAMSUNG	EP-TA200	N/A	Input: 100-240~, 50/60Hz, 0.5A; Output: 9V/1.67A or 5V/2A
Phone	SAMSUNG	SM-G9730	R28M3129AAF	N/A

3.5. Test procedure

- (1) The EUT was placed on a non-metallic table, 0.8m (table-top device)/0.1m (floor-stand device) above the ground plane.
- (2) Setup the EUT and assistant equipment as shown above block diagram and equipment list.
- (3) The EUT's power adapter was connected to the power mains through a line impedance stabilization network (L.I.S.N). which this provided a 50-ohm coupling impedance for the EUT (Please refer to the block diagram of the test setup and photographs). Both sides of power line were checked for maximum conducted disturbance. In order to find the maximum emission, the relative positions of equipment and all of the interface cables were changed according to EN 55032 on conducted disturbance emission test.
- (4) The bandwidth of test receiver is set at 9 kHz.
- (5) The frequency range from 150 kHz to 30 MHz is checked.

3.6. Test result

PASS. (See below detailed test result)

Note 1: All emissions not reported below are too low against the prescribed limits.

Note 2: "----" means Peak detection; "----" means Average detection.

TR-4-E-010 Conducted Emission Test Result

Test Site : DDT 1# Shield Room D:\2021 CE report date\Q21062936-1E\EN 55032 CE.EM6
Test Date : 2021-10-20 **Tested By** : Youbin He
EUT : Gaming Wireless Headset / USB **Model Number** : QUANTUM610 / QUANTUM610TM
 : Wireless Dongle **Test Mode** : Charging + Aux in mode
Power Supply : AC 240V/50Hz **LISN** : 2020 ENV 216 1#/NEUTRAL
Condition : TEMP:24.8°C, RH:53.8%, BP:101.4kPa
Memo :

Data: 2

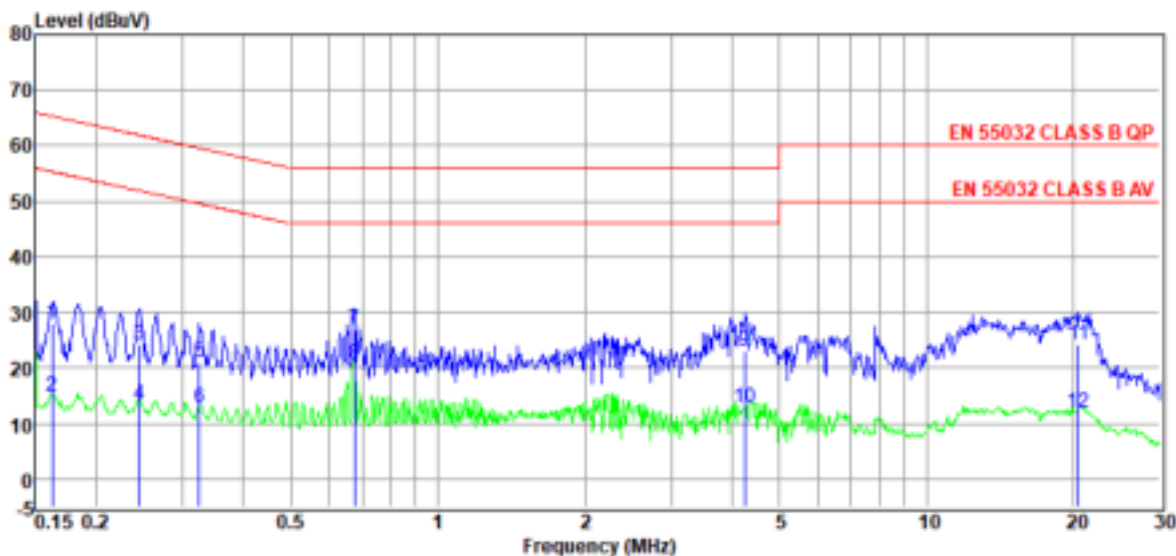

Item (Mark)	Freq. (MHz)	Read Level (dBμV)	LISN Factor (dB)	Cable Loss (dB)	Pulse Limiter Factor (dB)	Result Level (dBμV)	Limit Line (dBμV)	Over Limit (dB)	Detector	Phase
1	0.16	8.63	9.38	0.02	9.86	27.89	65.34	-37.45	QP	NEUTRAL
2	0.16	-4.31	9.38	0.02	9.86	14.95	55.34	-40.39	Average	NEUTRAL
3	0.24	5.09	9.37	0.02	9.86	24.34	61.95	-37.61	QP	NEUTRAL
4	0.24	-5.78	9.37	0.02	9.86	13.47	51.95	-38.48	Average	NEUTRAL
5	0.33	1.86	9.38	0.02	9.86	21.12	59.57	-38.45	QP	NEUTRAL
6	0.33	-6.58	9.38	0.02	9.86	12.68	49.57	-36.89	Average	NEUTRAL
7	0.68	7.56	9.39	0.03	9.86	26.84	56.00	-29.16	QP	NEUTRAL
8	0.68	1.33	9.39	0.03	9.86	20.61	46.00	-25.39	Average	NEUTRAL
9	4.25	3.77	9.44	0.07	9.87	23.15	56.00	-32.85	QP	NEUTRAL
10	4.25	-6.65	9.44	0.07	9.87	12.73	46.00	-33.27	Average	NEUTRAL
11	20.49	4.38	9.81	0.16	9.94	24.29	60.00	-35.71	QP	NEUTRAL
12	20.49	-8.06	9.81	0.16	9.94	11.85	50.00	-38.15	Average	NEUTRAL

Note:

1. Result Level = Read Level + LISN Factor + Pulse Limiter Factor + Cable loss.
2. If QP Result complies with AV limit, AV Result is deemed to comply with AV limit.
3. Test setup: RBW: 200 Hz (9 kHz—150 kHz), 9 kHz (150 kHz—30 MHz).
4. Step size: 80Hz (0.009MHz-0.15MHz), 4 kHz (0.15MHz-30MHz), Scan time: auto.

TR-4-E-010 Conducted Emission Test Result

Test Site : DDT 1# Shield Room **D:\2021 CE report date\Q21062936-1E\EN 55032 CE.EM6**
Test Date : 2021-10-20 **Tested By** : Youbin He
EUT : Gaming Wireless Headset / USB **Model Number** : QUANTUM610 / QUANTUM610TM
 : Wireless Dongle **Test Mode** : Charging + Aux in mode
Power Supply : AC 240V/50Hz **LISN** : 2020 ENV 216 1#/LINE
Condition : TEMP:24.8°C, RH:53.8%, BP:101.4kPa
Memo :

Data: 4

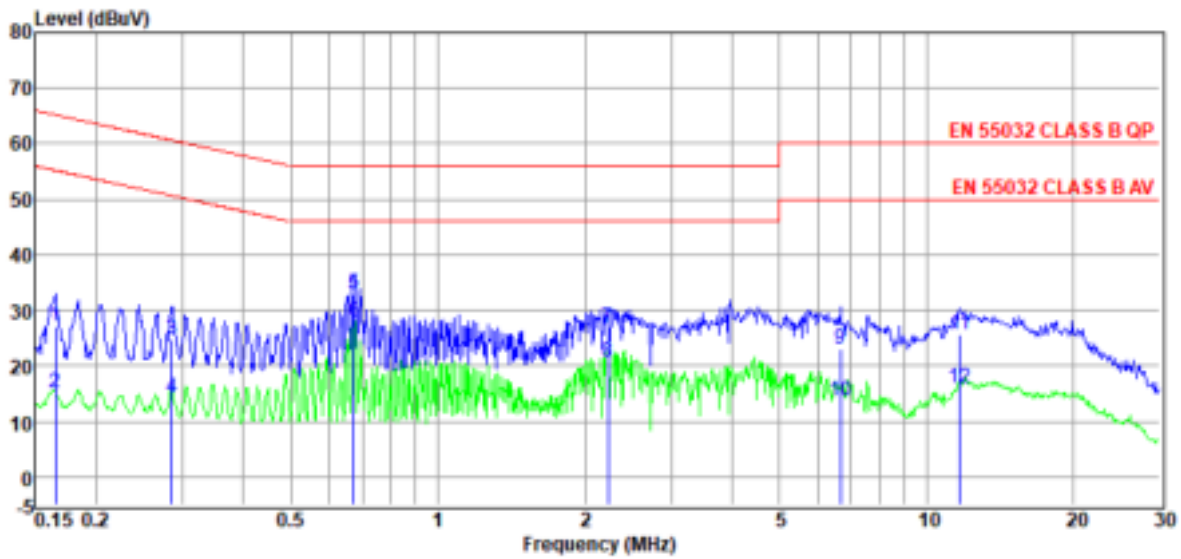

Item (Mark)	Freq. (MHz)	Read Level (dBμV)	LISN Factor (dB)	Cable Loss (dB)	Pulse Limiter Factor (dB)	Result Level (dBμV)	Limit Line (dBμV)	Over Limit (dB)	Detector	Phase
1	0.17	7.91	9.39	0.02	9.86	27.18	65.21	-38.03	QP	LINE
2	0.17	-4.18	9.39	0.02	9.86	15.09	55.21	-40.12	Average	LINE
3	0.28	5.37	9.41	0.02	9.86	24.66	60.68	-36.02	QP	LINE
4	0.28	-4.90	9.41	0.02	9.86	14.39	50.68	-36.29	Average	LINE
5	0.67	13.74	9.42	0.03	9.86	33.05	56.00	-22.95	QP	LINE
6	0.67	8.80	9.42	0.03	9.86	28.11	46.00	-17.89	Average	LINE
7	2.23	7.40	9.43	0.05	9.87	26.75	56.00	-29.25	QP	LINE
8	2.23	1.32	9.43	0.05	9.87	20.67	46.00	-25.33	Average	LINE
9	6.66	3.51	9.54	0.09	9.88	23.02	60.00	-36.98	QP	LINE
10	6.66	-5.90	9.54	0.09	9.88	13.61	50.00	-36.39	Average	LINE
11	11.68	6.06	9.61	0.12	9.90	25.69	60.00	-34.31	QP	LINE
12	11.68	-3.65	9.61	0.12	9.90	15.98	50.00	-34.02	Average	LINE

Note:

1. Result Level = Read Level + LISN Factor + Pulse Limiter Factor + Cable loss.
2. If QP Result complies with AV limit, AV Result is deemed to comply with AV limit.
3. Test setup: RBW: 200 Hz (9 kHz—150 kHz), 9 kHz (150 kHz—30 MHz).
4. Step size: 80Hz (0.009MHz-0.15MHz), 4 kHz (0.15MHz-30MHz), Scan time: auto.

TR-4-E-010 Conducted Emission Test Result

Test Site : DDT 1# Shield Room D:\2021 CE report date\Q21062936-1E\EN 55032 CE.EM6
Test Date : 2021-10-20 **Tested By** : Youbin He
EUT : Gaming Wireless Headset / USB **Model Number** : QUANTUM610 / QUANTUM610TM
 : Wireless Dongle **Test Mode** : Charging mode
Power Supply : AC 240V/50Hz **LISN** : 2020 ENV 216 1#/LINE
Condition : TEMP:24.8°C, RH:53.8%, BP:101.4kPa
Memo :

Data: 6

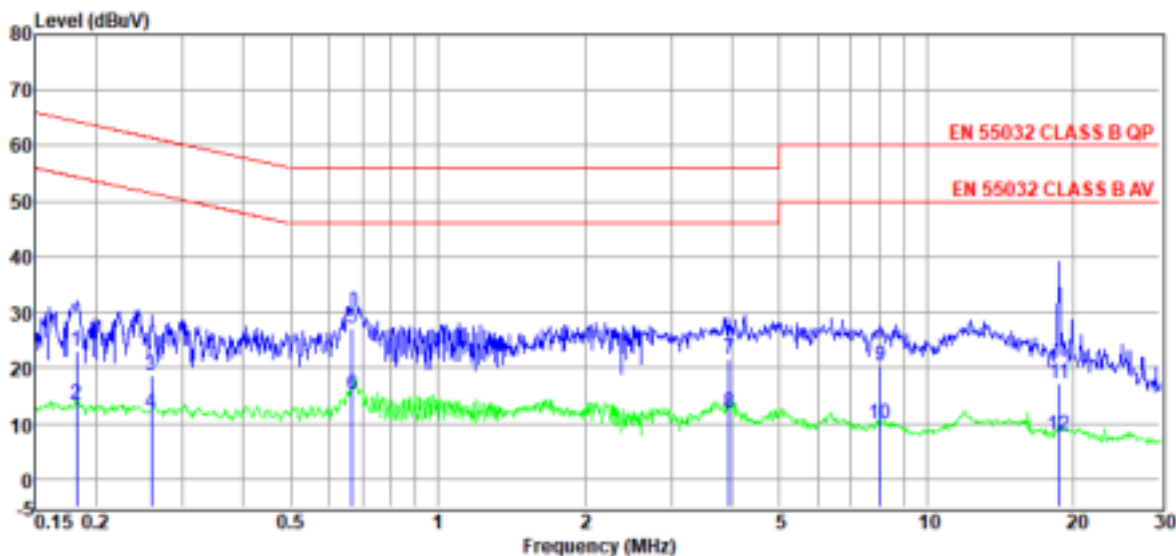

Item (Mark)	Freq. (MHz)	Read Level (dBμV)	LISN Factor (dB)	Cable Loss (dB)	Pulse Limiter Factor (dB)	Result Level (dBμV)	Limit Line (dBμV)	Over Limit (dB)	Detector	Phase
1	0.18	3.77	9.40	0.02	9.86	23.05	64.37	-41.32	QP	LINE
2	0.18	-5.87	9.40	0.02	9.86	13.41	54.37	-40.96	Average	LINE
3	0.26	-0.58	9.41	0.02	9.86	18.71	61.47	-42.76	QP	LINE
4	0.26	-7.24	9.41	0.02	9.86	12.05	51.47	-39.42	Average	LINE
5	0.67	7.94	9.42	0.03	9.86	27.25	56.00	-28.75	QP	LINE
6	0.67	-4.30	9.42	0.03	9.86	15.01	46.00	-30.99	Average	LINE
7	3.94	2.19	9.47	0.07	9.87	21.60	56.00	-34.40	QP	LINE
8	3.94	-7.38	9.47	0.07	9.87	12.03	46.00	-33.97	Average	LINE
9	8.02	0.82	9.57	0.10	9.88	20.37	60.00	-39.63	QP	LINE
10	8.02	-9.57	9.57	0.10	9.88	9.98	50.00	-40.02	Average	LINE
11	18.62	-2.58	9.79	0.15	9.94	17.30	60.00	-42.70	QP	LINE
12	18.62	-12.04	9.79	0.15	9.94	7.84	50.00	-42.16	Average	LINE

Note:

1. Result Level = Read Level + LISN Factor + Pulse Limiter Factor + Cable loss.
2. If QP Result complies with AV limit, AV Result is deemed to comply with AV limit.
3. Test setup: RBW: 200 Hz (9 kHz—150 kHz), 9 kHz (150 kHz—30 MHz).
4. Step size: 80Hz (0.009MHz-0.15MHz), 4 kHz (0.15MHz-30MHz), Scan time: auto.

TR-4-E-010 Conducted Emission Test Result

Test Site : DDT 1# Shield Room **D:\2021 CE report date\Q21062936-1E\EN 55032 CE.EM6**
Test Date : 2021-10-20 **Tested By** : Youbin He
EUT : Gaming Wireless Headset / USB **Model Number** : QUANTUM610 / QUANTUM610TM
 : Wireless Dongle **Test Mode** : Charging mode
Power Supply : AC 240V/50Hz **LISN** : 2020 ENV 216 1#/NEUTRAL
Condition : TEMP:24.8°C, RH:53.8%, BP:101.4kPa
Memo :

Data: 8

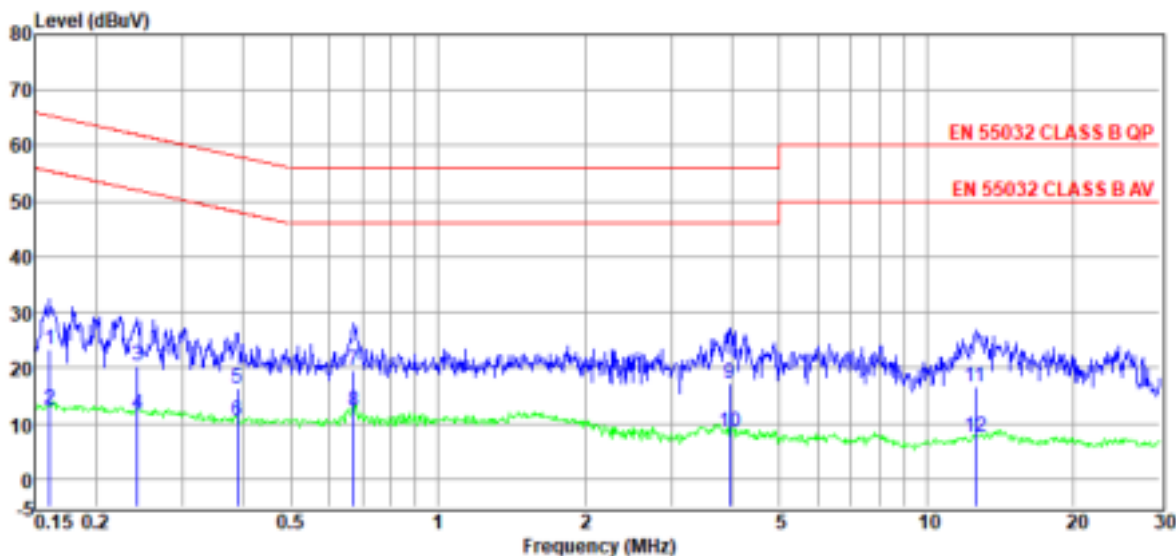

Item (Mark)	Freq. (MHz)	Read Level (dBμV)	LISN Factor (dB)	Cable Loss (dB)	Pulse Limiter Factor (dB)	Result Level (dBμV)	Limit Line (dBμV)	Over Limit (dB)	Detector	Phase
1	0.16	4.08	9.38	0.02	9.86	23.34	65.43	-42.09	QP	NEUTRAL
2	0.16	-6.65	9.38	0.02	9.86	12.61	55.43	-42.82	Average	NEUTRAL
3	0.24	1.06	9.37	0.02	9.86	20.31	62.00	-41.69	QP	NEUTRAL
4	0.24	-7.49	9.37	0.02	9.86	11.76	52.00	-40.24	Average	NEUTRAL
5	0.39	-3.07	9.39	0.02	9.86	16.20	58.08	-41.88	QP	NEUTRAL
6	0.39	-8.73	9.39	0.02	9.86	10.54	48.08	-37.54	Average	NEUTRAL
7	0.67	0.30	9.39	0.03	9.86	19.58	56.00	-36.42	QP	NEUTRAL
8	0.67	-7.09	9.39	0.03	9.86	12.19	46.00	-33.81	Average	NEUTRAL
9	3.96	-2.15	9.44	0.07	9.87	17.23	56.00	-38.77	QP	NEUTRAL
10	3.96	-11.05	9.44	0.07	9.87	8.33	46.00	-37.67	Average	NEUTRAL
11	12.58	-3.10	9.60	0.13	9.91	16.54	60.00	-43.46	QP	NEUTRAL
12	12.58	-11.99	9.60	0.13	9.91	7.65	50.00	-42.35	Average	NEUTRAL

Note:

1. Result Level = Read Level + LISN Factor + Pulse Limiter Factor + Cable loss.
2. If QP Result complies with AV limit, AV Result is deemed to comply with AV limit.
3. Test setup: RBW: 200 Hz (9 kHz—150 kHz), 9 kHz (150 kHz—30 MHz).
4. Step size: 80Hz (0.009MHz-0.15MHz), 4 kHz (0.15MHz-30MHz), Scan time: auto.

3.7. Test photo

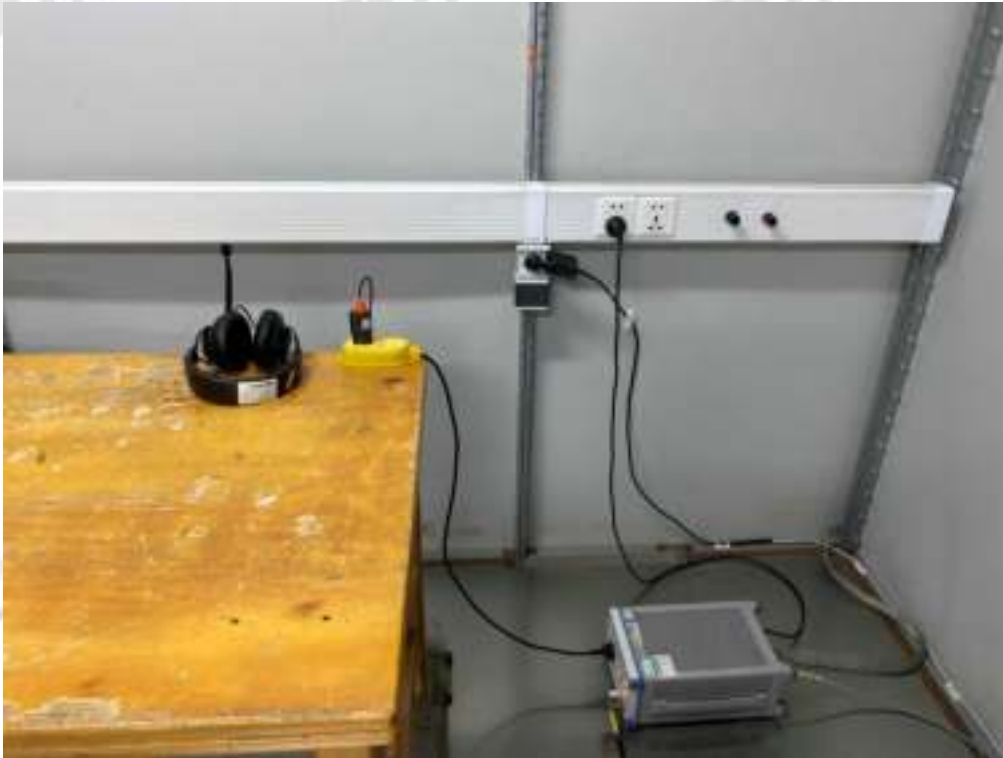



4. Radiated Emissions Test

4.1. Test equipment

Equipment	Manufacturer	Model No.	Serial No.	Last Cal.	Cal. Interval
<input checked="" type="checkbox"/> 1# Radiation chamber					
EMI Test Receiver	R&S	ESU8	100316	Sep. 02, 2021	1 Year
Spectrum analyzer	Agilent	E4447A	MY50180031	Jun. 01, 2021	1 Year
Trilog Broadband Antenna	Schwarzbeck	VULB9163	9163-462	Nov. 13, 2020	1 Year
Active Loop antenna	Schwarzbeck	FMZB-1519	1519-038	Sep. 19, 2021	1 Year
Double Ridged Horn Antenna	R&S	HF907	100276	Sep. 19, 2021	1 Year
Pre-amplifier	A.H.	PAM-0118	360	Sep. 09, 2021	1 Year
Pre-amplifier	TRLA-MW	TRLA-0040G35	101303	Sep. 02, 2021	1 Year
RF Cable	HUBSER	CP-X2+ CP-X1	W11.03+ W12.02	Sep. 02, 2021	1 Year
RF Cable	N/A	5m+6m+1m	06270619	Sep. 02, 2021	1 Year
MI Cable	HUBSER	C10-01-01-1M	1091629	Sep. 02, 2021	1 Year
Test software	Audix	E3	V 6.11111b	N/A	N/A
<input type="checkbox"/> 2# Radiation chamber					
EMI Test Receiver	R&S	ESCI	101028	Sep. 02, 2021	1 Year
Spectrum analyzer	Agilent	E4440A	MY46185770	Jun. 01, 2021	1 Year
Trilog Broadband Antenna	Schwarzbeck	VULB 9163	9163-994	Sep. 27, 2021	1 Year
Active Loop antenna	Schwarzbeck	FMZB-1519	1519-038	Sep. 19, 2021	1 Year
Double Ridged Horn Antenna	Schwarzbeck	BBHA9120D	9120D-2108	Jul. 17, 2021	1 Year
Pre-amplifier	A.H.	PAM-0118	18040084	Sep. 02, 2021	1 Year
Pre-amplifier	TRLA-MW	TRLA-0040G35	101303	Sep. 02, 2021	1 Year
RF Cable	MI Cable	RG214-11	DDT- ZC01497	Jun. 09, 2021	1 Year
Test software	Audix	E3	V 6.11111b	N/A	N/A
<input checked="" type="checkbox"/> Radiation DDT 10m 1#chamber (below 1G)					
Pre-amplifier	SONOMA	310N	187133	Jul. 06, 2021	1 Year
Pre-amplifier	SONOMA	310N	310816	Jul. 06, 2021	1 Year
EMI Test Receiver	R&S	ESC17	100783	Jun. 01, 2021	1 Year
EMI Test Receiver	R&S	ESCI	101026	Mar. 03, 2021	1 Year
Trilog Broadband Antenna	Schwarzbeck	VULB9163	01426	Aug. 07, 2021	1 Year
Trilog Broadband Antenna	Schwarzbeck	VULB9163	01427	Aug. 07, 2021	1 Year
Notes. N/A means Not applicable.					

4.2. Block diagram of test setup

Below 1 GHz

For table-top equipment

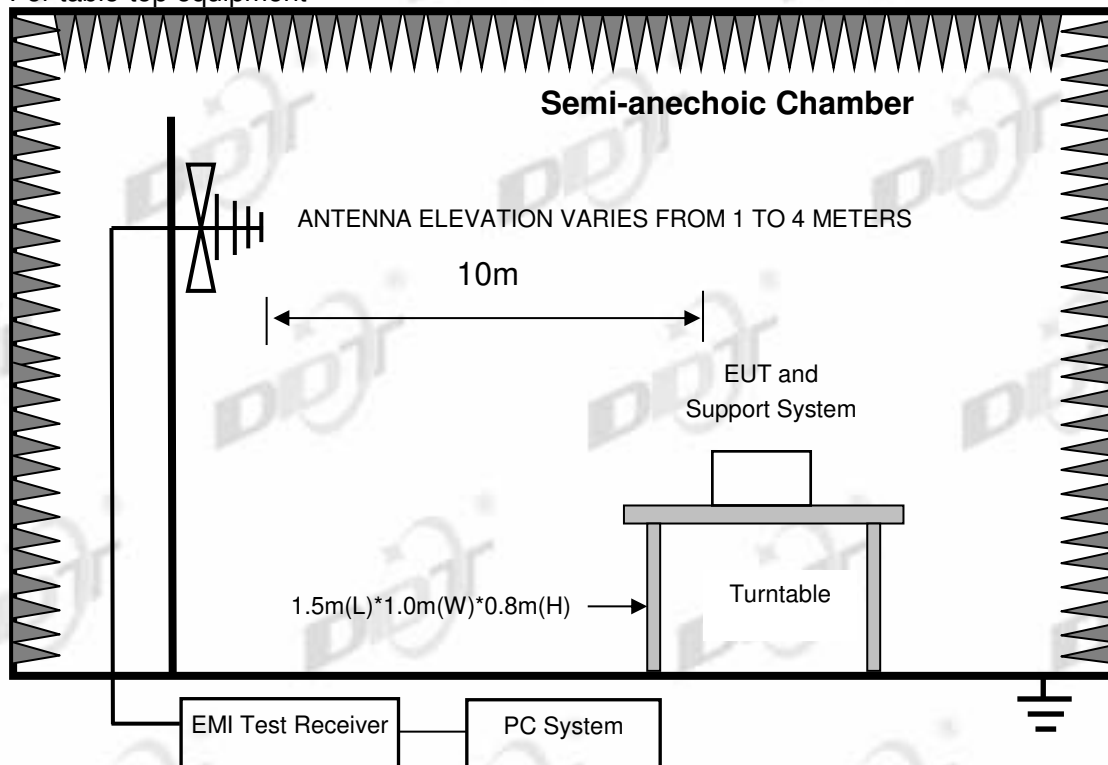

For floor standing equipment

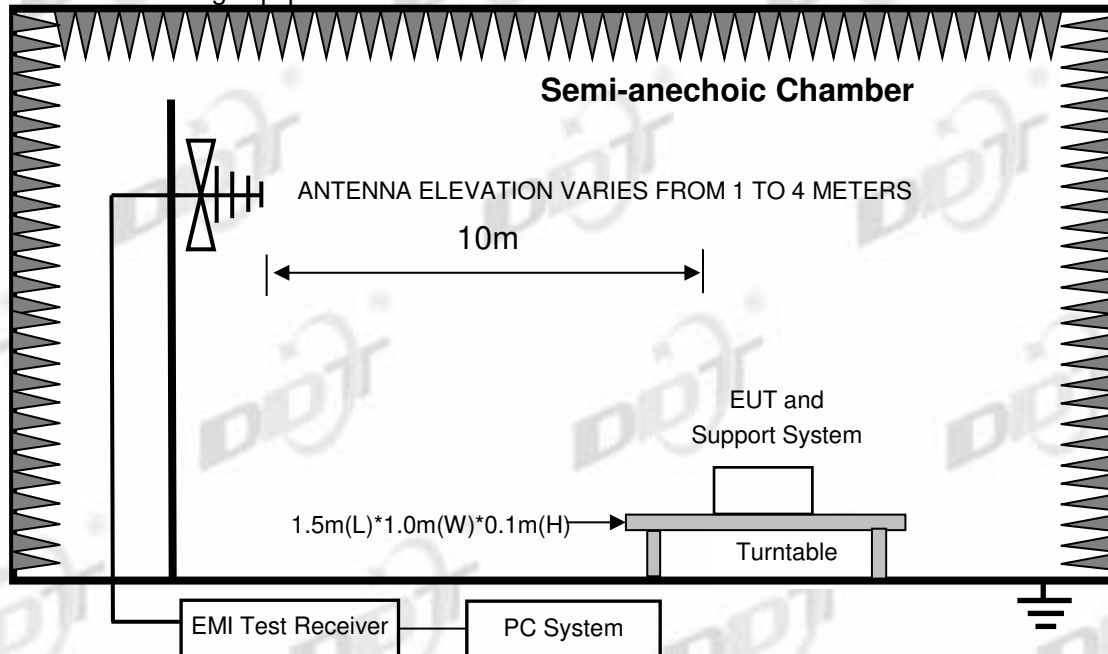

Above 1 GHz
For table-top equipment

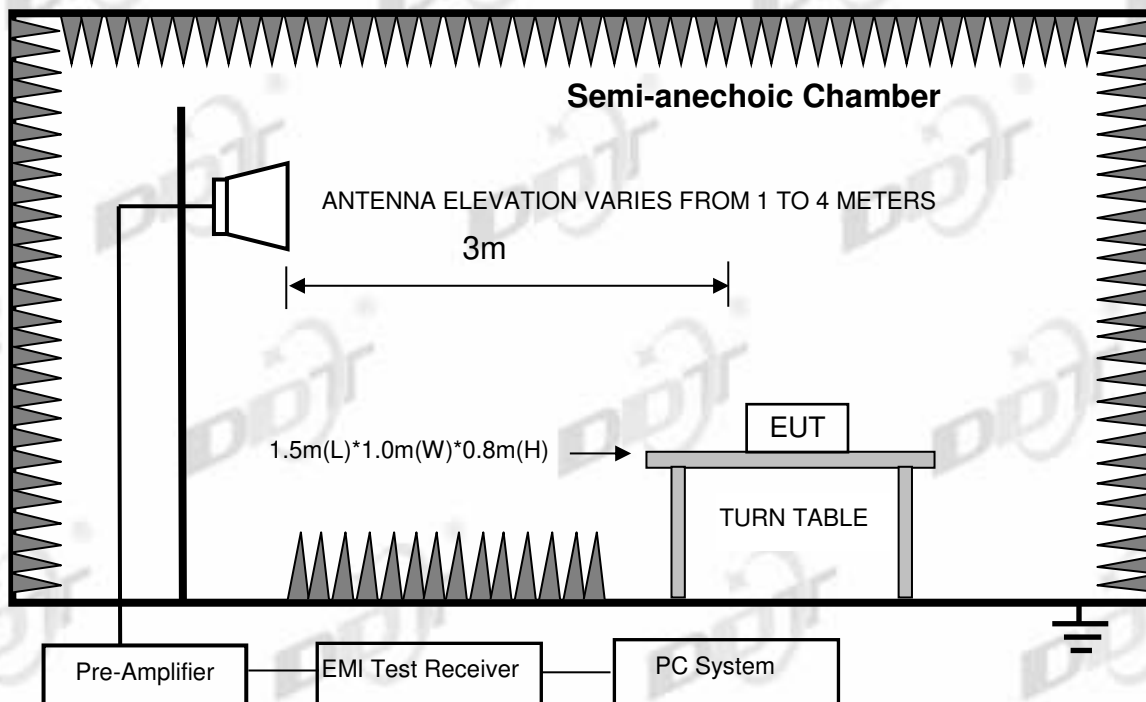

For floor standing equipment

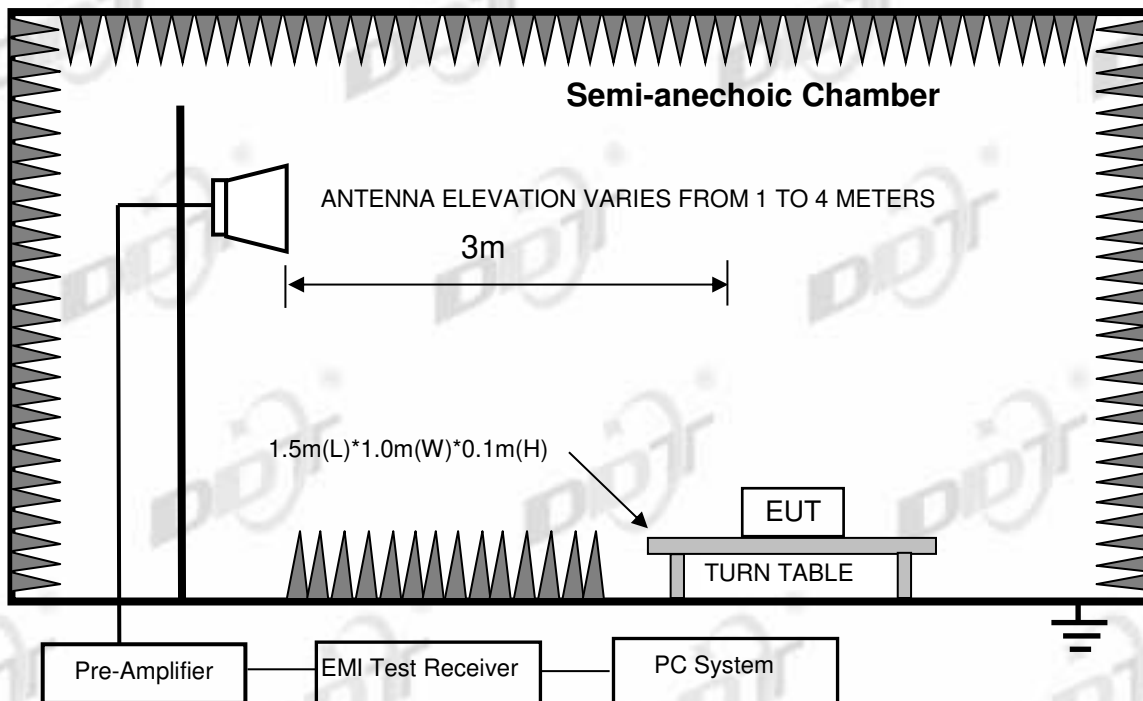

For combinations equipment

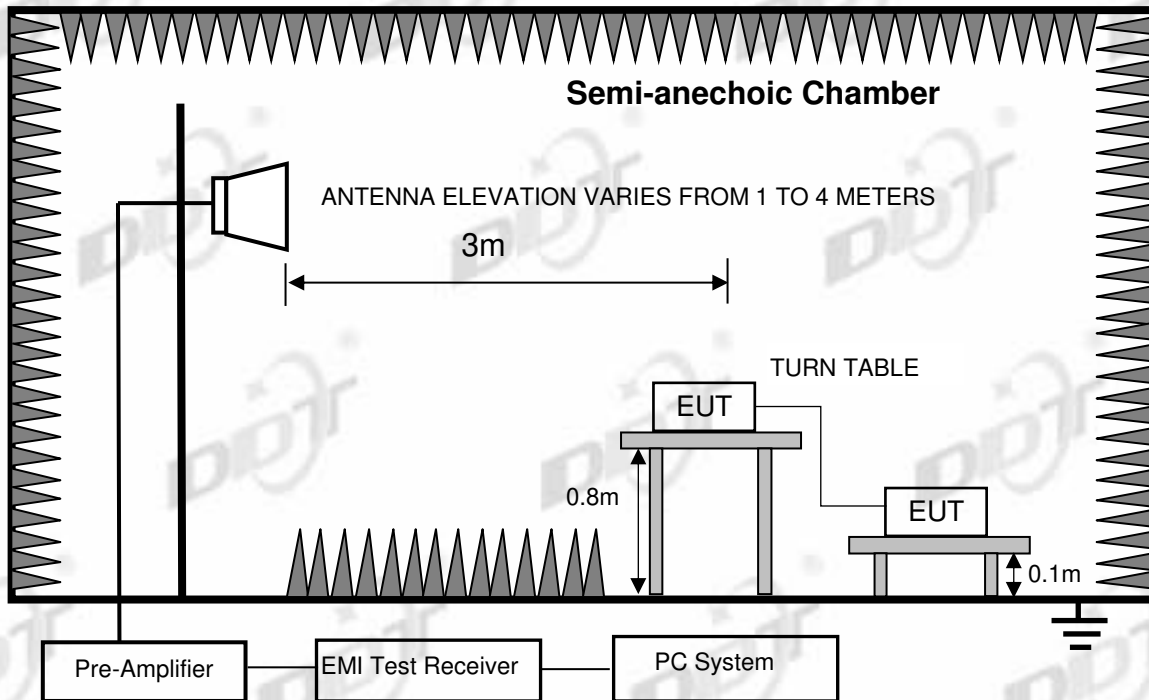

4.3. Limits

Class A

Equipment	Frequency	Field Strengths Limits at 10m measuring distance dB(μV)/m	Field Strengths Limits at 3m measuring distance dB(μV)/m
Class A Equipment	30 MHz to 230 MHz	40	50
	230 MHz to 1 GHz	47	57
	1 GHz to 3 GHz	/	Average:56; Peak:76
	3 GHz to 6 GHz	/	Average:60; Peak:80

Class B

Equipment	Frequency	Field Strengths Limits at 10m measuring distance dB(μV)/m	Field Strengths Limits at 3m measuring distance dB(μV)/m
Class B Equipment	30 MHz to 230 MHz	30	40
	230 MHz to 1 GHz	37	47
	1 GHz to 3 GHz	/	Average:50; Peak:70
	3 GHz to 6 GHz	/	Average:54; Peak:74
FM receivers*	30 MHz to 1 GHz	Fundamental 50	Fundamental 60
	30 MHz to 300 MHz	Harmonics 42	Harmonics 52
	300 MHz to 1 GHz	Harmonics 46	Harmonics 56

*: these relaxed limits apply only to emission at the fundamental and harmonic frequencies of the local oscillator signals at all other frequencies shall be compliant with the limits of class B equipment given above.

Note: (1) The smaller limit shall apply at the cross point between two frequency bands.

(2) Distance is the distance in meters between the measuring instrument, antenna and the closest point of any part of the device or system.

4.4. Assistant equipment used for test

Assistant equipment	Manufacturer	Model number	Description	other
Adapter	SAMSUNG	EP-TA200	N/A	Input: 100-240~, 50/60Hz, 0.5A; Output: 9V/1.67A or 5V/2A
Phone	SAMSUNG	SM-G9730	R28M3129AAF	N/A

4.5. Test procedure

- (1) The EUT was placed on a non-metallic table, 0.8m (table-top device)/0.1m (floor-stand device) above the ground plane inside a semi-anechoic chamber.
- (2) Test antenna was located 3m from the EUT on an adjustable mast. A pre-scan was first performed in order to find prominent radiated emissions. For final emissions measurements at each frequency of interest, the EUT were rotated and the antenna height was varied between 1m and 4m in order to maximize the emission. Measurements in both horizontal and vertical polarities were made and the data was recorded. In order to find the maximum emission, the relative positions of equipment and all of the interface cables were changed according to EN 55032 on radiated emission test.
- (3) Spectrum frequency from 30 MHz to 1 GHz/6 GHz was investigated.
- (4) For final emissions measurements at each frequency of interest, the EUT were rotated and the antenna height was varied between 1m and 4m in order to maximize the emission. Measurements in both horizontal and vertical polarities were made and the data was recorded. In order to find the maximum emission, the relative positions of equipment and all of the interface cables were changed according to EN 55032 on Radiated Emission test.
- (5) For emissions from 30 MHz to 1 GHz, Quasi-Peak values were measured with EMI Receiver and the bandwidth of Receiver is 120 kHz.
- (6) For emissions above 1 GHz, both Peak and Average level were measured with Spectrum Analyzer, and the RBW is set at 1 MHz VBW is set at 3 MHz.

4.6. Test result

PASS. (See below detailed test result)

Note 1: All emissions not reported below are too low against the prescribed limits;

Note 2: "----" means Peak detection.

TR-4-E-009 Radiated Emission Test Result

Test Site : DDT 10M Chamber **D:\2021 report data\Q21062936-1EVEN 55032 RE.EM6**
Test Date : 2021-10-21 **Tested By** : Cut Zhuang
EUT : Gaming Wireless Headset / USB Wireless Dongle **Model Number** : QUANTUM610 / QUANTUM610TM
Power Supply : Battery **Test Mode** : Aux in mode
Condition : Temp:24.5°C,Humi:56%,Press:101.4kPa **Antenna/Distance** : VLUB 9163 A/10m/VERTICAL
Memo :

Data: 1

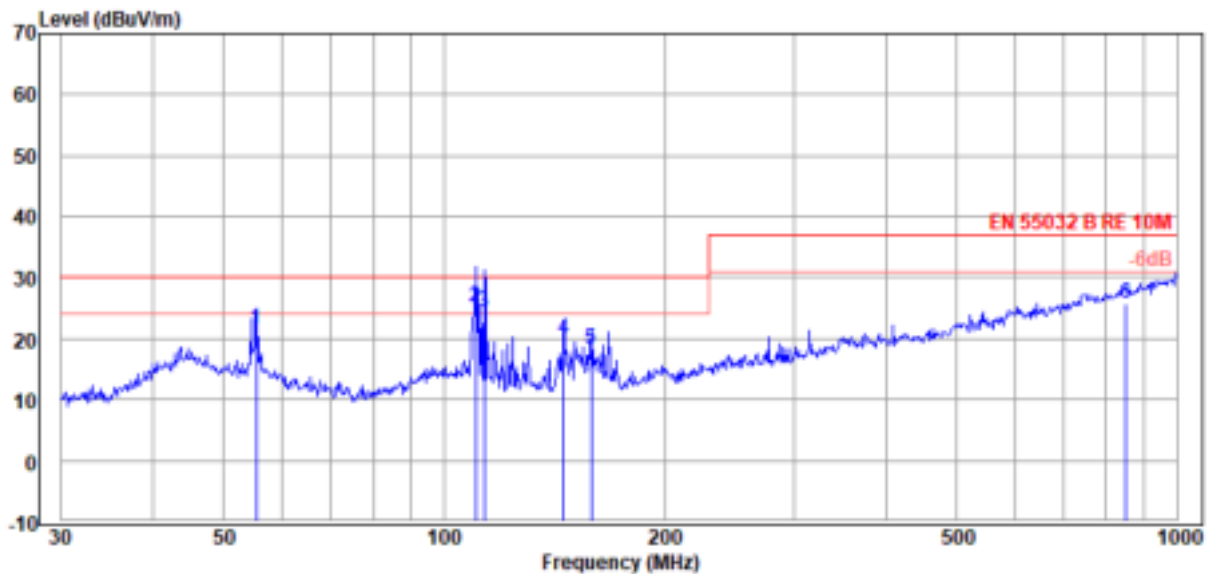

Item (Mark)	Freq. (MHz)	Read Level (dBμV)	Antenna Factor (dB/m)	PRM Factor (dB)	Cable Loss (dB)	Result Level (dBμV/m)	Limit Line (dBμV/m)	Over Limit (dB)	Detector	Polarization
1	55.42	34.72	11.92	32.10	7.19	21.73	30.00	-8.27	QP	VERTICAL
2	110.18	38.61	10.46	32.08	8.13	25.12	30.00	-4.88	QP	VERTICAL
3	113.32	38.19	9.97	32.07	8.18	24.27	30.00	-5.73	QP	VERTICAL
4	145.35	36.10	7.80	32.01	8.01	19.90	30.00	-10.10	QP	VERTICAL
5	158.67	33.97	8.47	32.00	7.99	18.43	30.00	-11.57	QP	VERTICAL
6	851.04	26.13	21.00	31.24	9.90	25.79	37.00	-11.21	QP	VERTICAL

Note: 1. Result Level = Read Level + Antenna Factor + Cable loss - PRM Factor.
 2. If Peak Result complies with QP limit, QP Result is deemed to comply with QP limit.
 3. Test setup: RBW: 120 kHz, VBW: 300 kHz, Sweep time: auto.

TR-4-E-009 Radiated Emission Test Result

Test Site : DDT 10M Chamber **D:\2021 report data\Q21062936-1EVEN 55032 RE.EM6**
Test Date : 2021-10-21 **Tested By** : Cut Zhuang
EUT : Gaming Wireless Headset / USB Wireless Dongle **Model Number** : QUANTUM610 / QUANTUM610TM
Power Supply : Battery **Test Mode** : Aux in mode
Condition : Temp:24.5°C,Humi:56%,Press:101.4kPa **Antenna/Distance** : VLUB 9163 B/10m/HORIZONTAL
Memo :

Data: 2

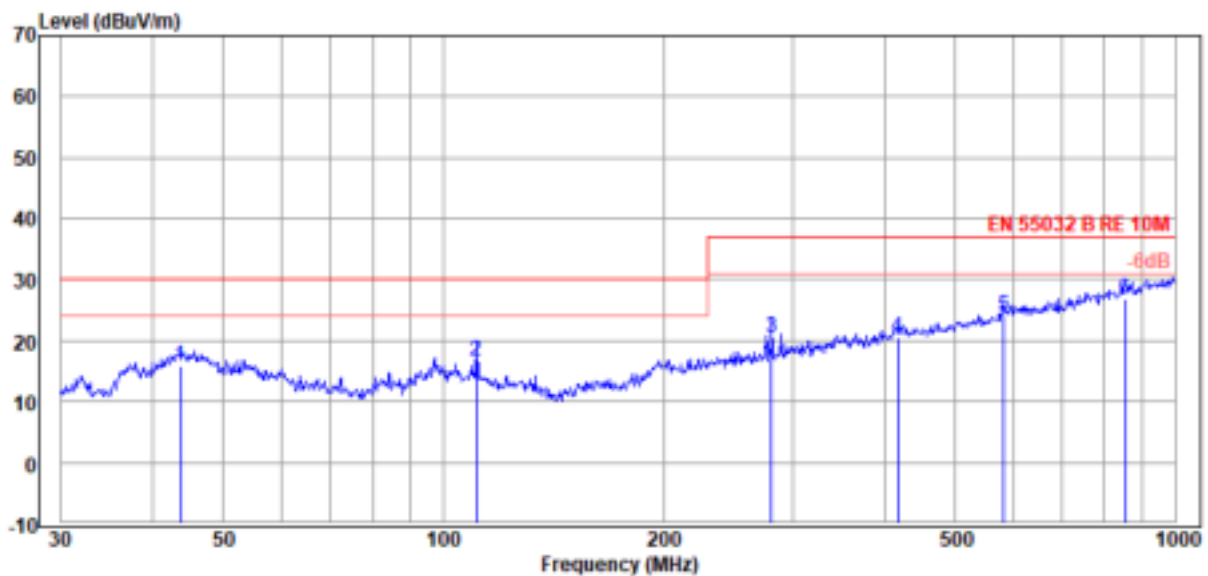

Item (Mark)	Freq. (MHz)	Read Level (dBμV)	Antenna Factor (dB/m)	PRM Factor (dB)	Cable Loss (dB)	Result Level (dBμV/m)	Limit Line (dBμV/m)	Over Limit (dB)	Detector	Polarization
1	43.66	25.66	14.70	31.60	7.14	15.90	30.00	-14.10	QP	HORIZONTAL
2	110.96	30.25	10.30	31.54	7.63	16.64	30.00	-13.36	QP	HORIZONTAL
3	281.01	30.47	12.84	31.42	8.55	20.44	37.00	-16.56	QP	HORIZONTAL
4	417.64	26.98	15.90	31.54	9.26	20.60	37.00	-16.40	QP	HORIZONTAL
5	582.74	27.57	18.36	31.78	9.91	24.06	37.00	-12.94	QP	HORIZONTAL
6	854.03	26.32	21.08	31.48	10.81	26.73	37.00	-10.27	QP	HORIZONTAL

Note: 1. Result Level = Read Level + Antenna Factor + Cable loss - PRM Factor.
 2. If Peak Result complies with QP limit, QP Result is deemed to comply with QP limit.
 3. Test setup: RBW: 120 kHz, VBW: 300 kHz, Sweep time: auto.

TR-4-E-009 Radiated Emission Test Result

Test Site : DDT 10M Chamber **D:\2021 report data\Q21062936-1EVEN 55032 RE.EM6**
Test Date : 2021-10-21 **Tested By** : Cut Zhuang
EUT : Gaming Wireless Headset / USB Wireless Dongle **Model Number** : QUANTUM610 / QUANTUM610TM
Power Supply : AC 240V/50Hz **Test Mode** : Charging + Aux in mode
Condition : Temp:24.5°C,Humi:56%,Press:101.4kPa **Antenna/Distance** : VLUB 9163 A/10m/VERTICAL
Memo :

Data: 3

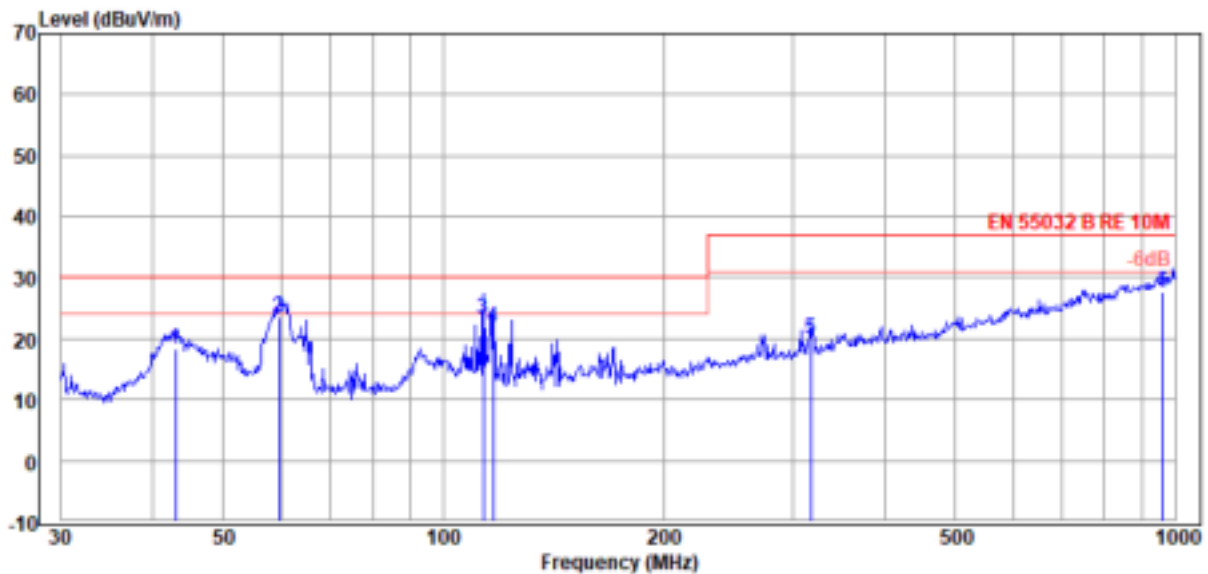

Item (Mark)	Freq. (MHz)	Read Level (dBμV)	Antenna Factor (dB/m)	PRM Factor (dB)	Cable Loss (dB)	Result Level (dBμV/m)	Limit Line (dBμV/m)	Over Limit (dB)	Detector	Polarization
1	43.05	29.13	14.33	32.10	7.05	18.41	30.00	-11.59	QP	VERTICAL
2	59.65	37.25	11.07	32.10	7.21	23.43	30.00	-6.57	QP	VERTICAL
3	113.32	37.29	9.97	32.07	8.18	23.37	30.00	-6.63	QP	VERTICAL
4	116.95	36.42	9.41	32.06	8.23	22.00	30.00	-8.00	QP	VERTICAL
5	317.70	29.63	13.65	31.78	8.51	20.01	37.00	-16.99	QP	VERTICAL
6	962.16	26.02	21.94	30.43	10.13	27.66	37.00	-9.34	QP	VERTICAL

Note: 1. Result Level = Read Level + Antenna Factor + Cable loss - PRM Factor.
 2. If Peak Result complies with QP limit, QP Result is deemed to comply with QP limit.
 3. Test setup: RBW: 120 kHz, VBW: 300 kHz, Sweep time: auto.

TR-4-E-009 Radiated Emission Test Result

Test Site : DDT 10M Chamber **D:\2021 report data\Q21062936-1EVEN 55032 RE.EM6**
Test Date : 2021-10-21 **Tested By** : Cut Zhuang
EUT : Gaming Wireless Headset / USB Wireless Dongle **Model Number** : QUANTUM610 / QUANTUM610TM
Power Supply : AC 240V/50Hz **Test Mode** : Charging + Aux in mode
Condition : Temp:24.5°C,Humi:56%,Press:101.4kPa **Antenna/Distance** : VLUB 9163 B/10m/HORIZONTAL
Memo :

Data: 4

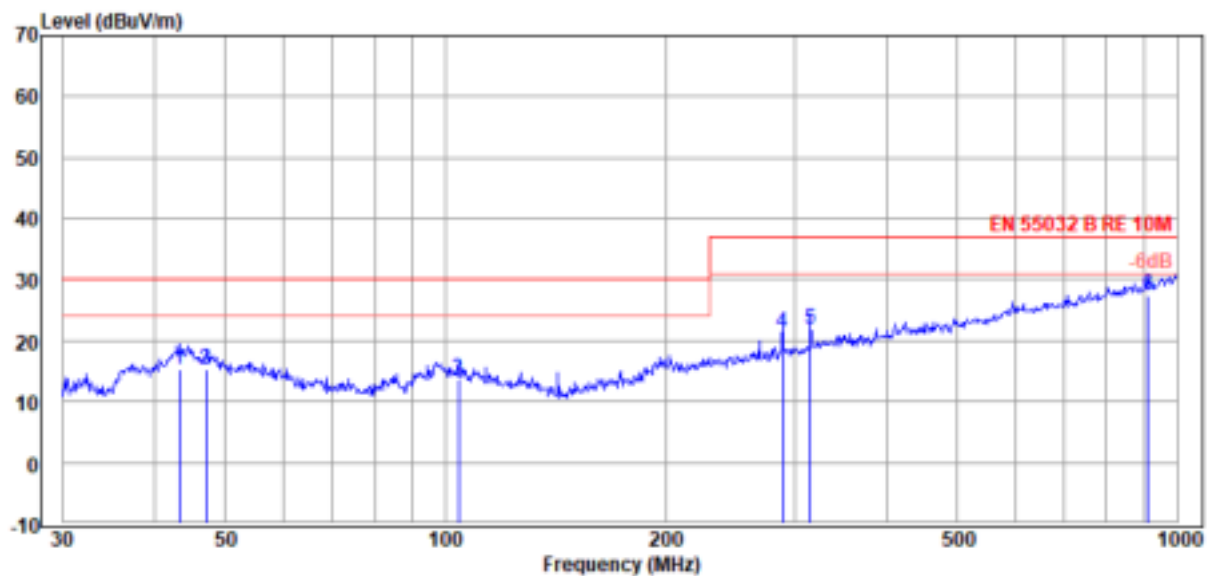

Item (Mark)	Freq. (MHz)	Read Level (dBμV)	Antenna Factor (dB/m)	PRM Factor (dB)	Cable Loss (dB)	Result Level (dBμV/m)	Limit Line (dBμV/m)	Over Limit (dB)	Detector	Polarization
1	43.20	25.34	14.42	31.60	7.13	15.29	30.00	-14.71	QP	HORIZONTAL
2	47.00	25.81	13.90	31.60	7.16	15.27	30.00	-14.73	QP	HORIZONTAL
3	104.17	26.26	11.28	31.55	7.58	13.57	30.00	-16.43	QP	HORIZONTAL
4	289.00	31.21	13.00	31.41	8.59	21.39	37.00	-15.61	QP	HORIZONTAL
5	315.48	31.07	13.62	31.42	8.71	21.98	37.00	-15.02	QP	HORIZONTAL
6	912.86	25.61	22.01	31.18	10.92	27.36	37.00	-9.64	QP	HORIZONTAL

Note: 1. Result Level = Read Level + Antenna Factor + Cable loss - PRM Factor.
 2. If Peak Result complies with QP limit, QP Result is deemed to comply with QP limit.
 3. Test setup: RBW: 120 kHz, VBW: 300 kHz, Sweep time: auto.

TR-4-E-009 Radiated Emission Test Result

Test Site : DDT 10M Chamber **D:\2021 report data\Q21062936-1EVEN 55032 RE.EM6**
Test Date : 2021-10-21 **Tested By** : Cut Zhuang
EUT : Gaming Wireless Headset / USB Wireless Dongle **Model Number** : QUANTUM610 / QUANTUM610TM
Power Supply : AC 240V/50Hz **Test Mode** : Charging mode
Condition : Temp:24.5°C,Humi:56%,Press:101.4kPa **Antenna/Distance** : VLUB 9163 A/10m/VERTICAL
Memo :

Data: 9

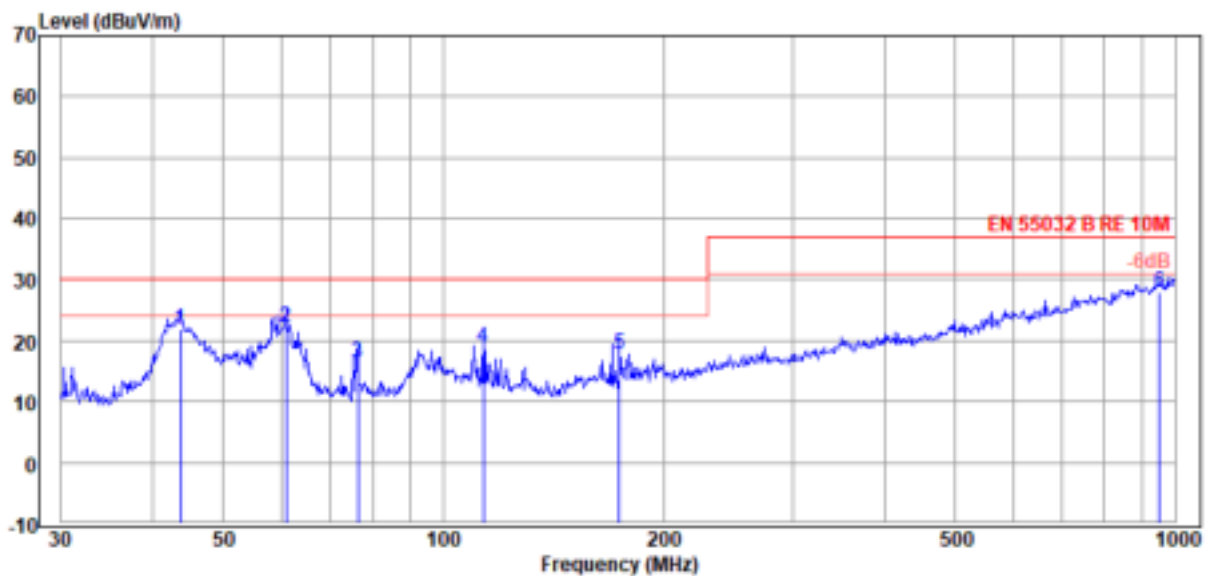

Item (Mark)	Freq. (MHz)	Read Level (dBμV)	Antenna Factor (dB/m)	PRM Factor dB	Cable Loss dB	Result Level (dBμV/m)	Limit Line (dBμV/m)	Over Limit (dB)	Detector	Polarization
1	43.66	32.22	14.70	32.10	7.06	21.88	30.00	-8.12	QP	VERTICAL
2	60.92	36.41	10.63	32.10	7.22	22.16	30.00	-7.84	QP	VERTICAL
3	76.24	32.68	8.25	32.10	7.48	16.31	30.00	-13.69	QP	VERTICAL
4	113.32	32.81	9.97	32.07	8.18	18.89	30.00	-11.11	QP	VERTICAL
5	173.81	32.71	8.90	32.00	8.03	17.64	30.00	-12.36	QP	VERTICAL
6	952.09	26.35	21.96	30.52	10.07	27.86	37.00	-9.14	QP	VERTICAL

Note: 1. Result Level = Read Level + Antenna Factor + Cable loss - PRM Factor.
 2. If Peak Result complies with QP limit, QP Result is deemed to comply with QP limit.
 3. Test setup: RBW: 120 kHz, VBW: 300 kHz, Sweep time: auto.

TR-4-E-009 Radiated Emission Test Result

Test Site : DDT 10M Chamber **D:\2021 report data\Q21062936-1EVEN 55032 RE.EM6**
Test Date : 2021-10-21 **Tested By** : Cut Zhuang
EUT : Gaming Wireless Headset / USB Wireless Dongle **Model Number** : QUANTUM610 / QUANTUM610TM
Power Supply : AC 240V/50Hz **Test Mode** : Charging mode
Condition : Temp:24.5°C,Humi:56%,Press:101.4kPa **Antenna/Distance** : VLUB 9163 B/10m/HORIZONTAL
Memo :

Data: 10

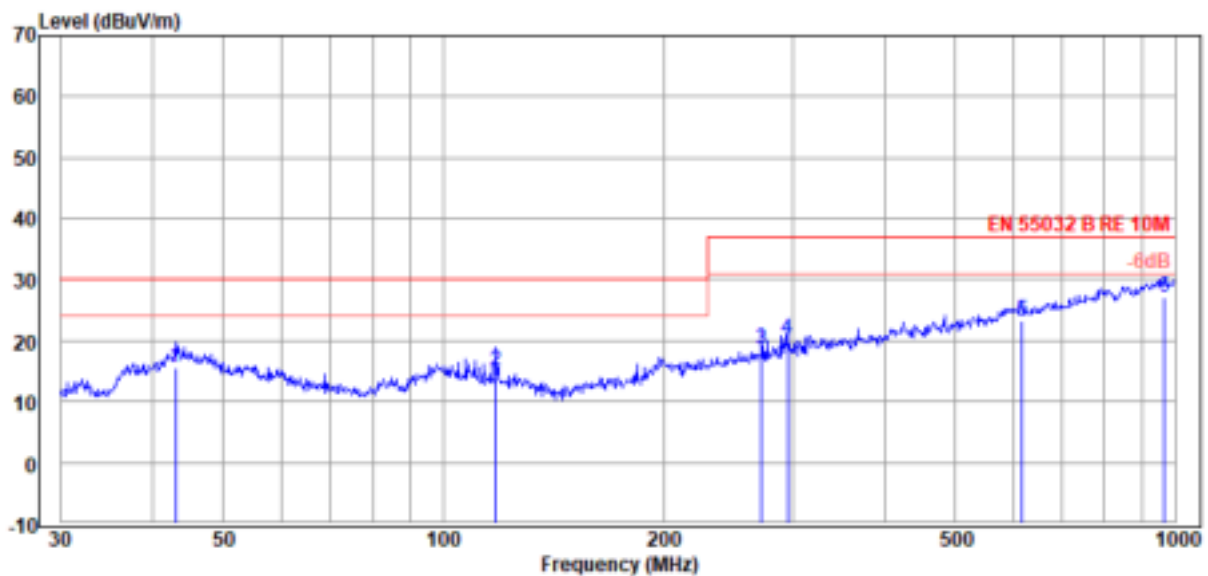

Item (Mark)	Freq. (MHz)	Read Level (dBμV)	Antenna Factor (dB/m)	PRM Factor (dB)	Cable Loss (dB)	Result Level (dBμV/m)	Limit Line (dBμV/m)	Over Limit (dB)	Detector	Polarization
1	43.05	25.75	14.33	31.60	7.13	15.61	30.00	-14.39	QP	HORIZONTAL
2	117.77	29.52	9.32	31.54	7.68	14.98	30.00	-15.02	QP	HORIZONTAL
3	272.28	28.82	12.70	31.42	8.51	18.61	37.00	-18.39	QP	HORIZONTAL
4	295.15	29.90	13.11	31.40	8.62	20.23	37.00	-16.77	QP	HORIZONTAL
5	618.54	25.99	18.86	31.76	10.08	23.17	37.00	-13.83	QP	HORIZONTAL
6	965.54	24.45	22.10	30.70	11.13	26.98	37.00	-10.02	QP	HORIZONTAL

Note: 1. Result Level = Read Level + Antenna Factor + Cable loss - PRM Factor.
 2. If Peak Result complies with QP limit, QP Result is deemed to comply with QP limit.
 3. Test setup: RBW: 120 kHz, VBW: 300 kHz, Sweep time: auto.

TR-4-E-009 Radiated Emission Test Result

Test Site : DDT 10M Chamber **D:\2021 report data\Q21062936-1EVEN 55032 RE.EM6**
Test Date : 2021-10-21 **Tested By** : Cut Zhuang
EUT : Gaming Wireless Headset / USB Wireless Dongle **Model Number** : QUANTUM610 / QUANTUM610TM
Power Supply : AC 240V/50Hz **Test Mode** : Standby mode
Condition : Temp:24.5°C,Humi:56%,Press:101.4kPa **Antenna/Distance** : VLUB 9163 A/10m/VERTICAL
Memo :

Data: 11

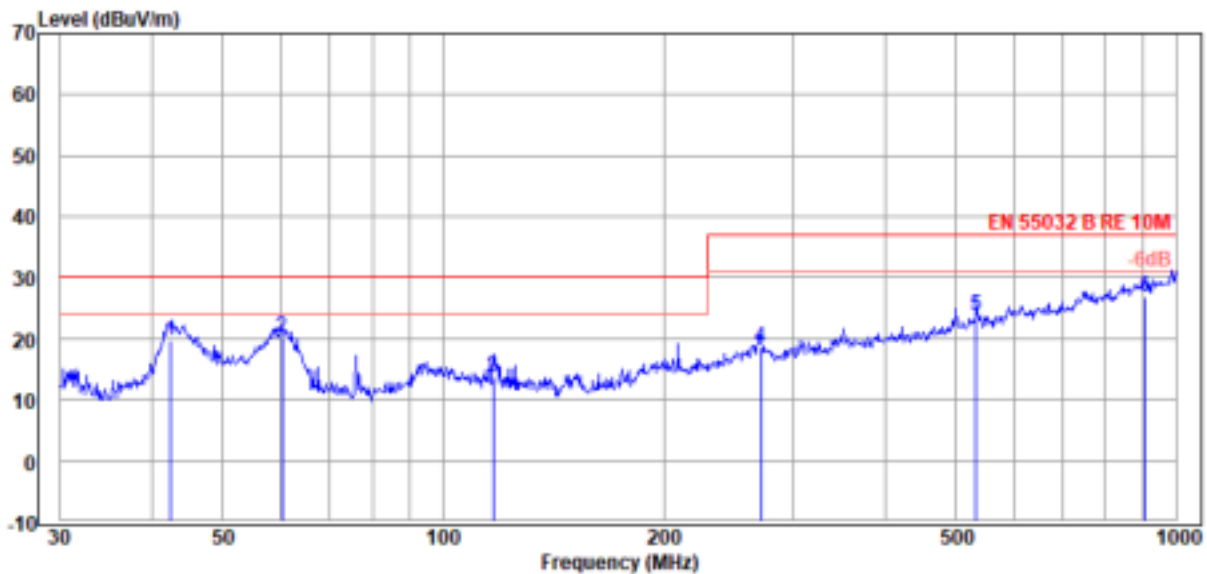

Item (Mark)	Freq. (MHz)	Read Level (dB μ V)	Antenna Factor (dB/m)	PRM Factor dB	Cable Loss dB	Result Level (dB μ V/m)	Limit Line (dB μ V/m)	Over Limit (dB)	Detector	Polarization
1	42.45	30.69	13.97	32.10	7.04	19.60	30.00	-10.40	QP	VERTICAL
2	60.28	34.25	10.89	32.10	7.21	20.25	30.00	-9.75	QP	VERTICAL
3	116.95	28.03	9.41	32.06	8.23	13.61	30.00	-16.39	QP	VERTICAL
4	271.33	29.63	12.63	31.84	8.26	18.68	37.00	-18.32	QP	VERTICAL
5	533.83	29.26	17.48	31.99	9.12	23.87	37.00	-13.13	QP	VERTICAL
6	906.48	25.86	21.83	30.94	9.99	26.74	37.00	-10.26	QP	VERTICAL

- Note: 1. Result Level = Read Level + Antenna Factor + Cable loss - PRM Factor.
 2. If Peak Result complies with QP limit, QP Result is deemed to comply with QP limit.
 3. Test setup: RBW: 120 kHz, VBW: 300 kHz, Sweep time: auto.

TR-4-E-009 Radiated Emission Test Result

Test Site : DDT 10M Chamber **D:\2021 report data\Q21062936-1EVEN 55032 RE.EM6**
Test Date : 2021-10-21 **Tested By** : Cut Zhuang
EUT : Gaming Wireless Headset / USB Wireless Dongle **Model Number** : QUANTUM610 / QUANTUM610TM
Power Supply : AC 240V/50Hz **Test Mode** : Standby mode
Condition : Temp:24.5°C,Humi:56%,Press:101.4kPa **Antenna/Distance** : VLUB 9163 B/10m/HORIZONTAL
Memo :

Data: 12

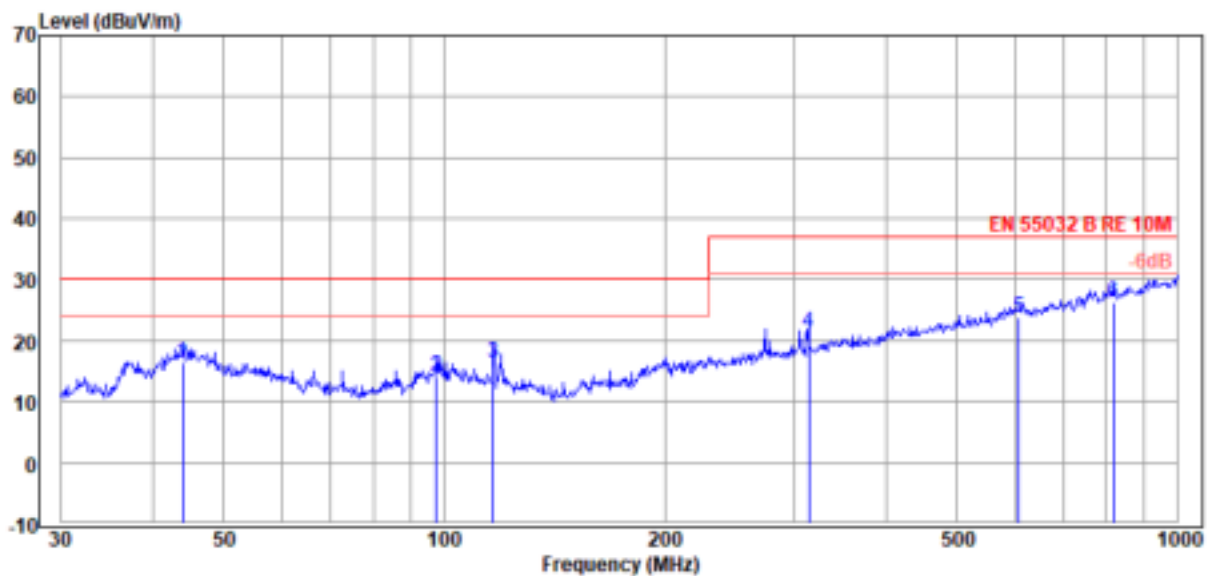

Item (Mark)	Freq. (MHz)	Read Level (dBμV)	Antenna Factor (dB/m)	PRM Factor (dB)	Cable Loss (dB)	Result Level (dBμV/m)	Limit Line (dBμV/m)	Over Limit (dB)	Detector	Polarization
1	43.97	25.92	14.88	31.60	7.14	16.34	30.00	-13.66	QP	HORIZONTAL
2	97.46	26.70	11.45	31.55	7.49	14.09	30.00	-15.91	QP	HORIZONTAL
3	116.54	30.76	9.49	31.54	7.67	16.38	30.00	-13.62	QP	HORIZONTAL
4	314.38	30.60	13.58	31.42	8.71	21.47	37.00	-15.53	QP	HORIZONTAL
5	607.79	26.59	18.96	31.78	10.04	23.81	37.00	-13.19	QP	HORIZONTAL
6	818.83	26.58	20.60	31.62	10.78	26.34	37.00	-10.66	QP	HORIZONTAL

Note: 1. Result Level = Read Level + Antenna Factor + Cable loss - PRM Factor.
 2. If Peak Result complies with QP limit, QP Result is deemed to comply with QP limit.
 3. Test setup: RBW: 120 kHz, VBW: 300 kHz, Sweep time: auto.

Radiated emission test (1 GHz-6 GHz)

TR-4-E-009 Radiated Emission Test Result

Test Site : DDT 3m Chamber 1# **D:\2021 RE 1# Report data\Q21062936-1E\1020 RE-H.EM6**

Test Date : 2021-10-20 **Tested By** : Bote Huang

EUT : Gaming Wireless Headset / USB Wireless Dongle **Model Number** : QUANTUM610 / QUANTUM610TM

Power Supply : AC 240V/50Hz **Test Mode** : Charging mode

Condition : Temp:24.5°C,Humi:55%,Press:101.4kPa **Antenna/Distance** : 2020 HF907/3m/VERTICAL

Memo :

Data: 21

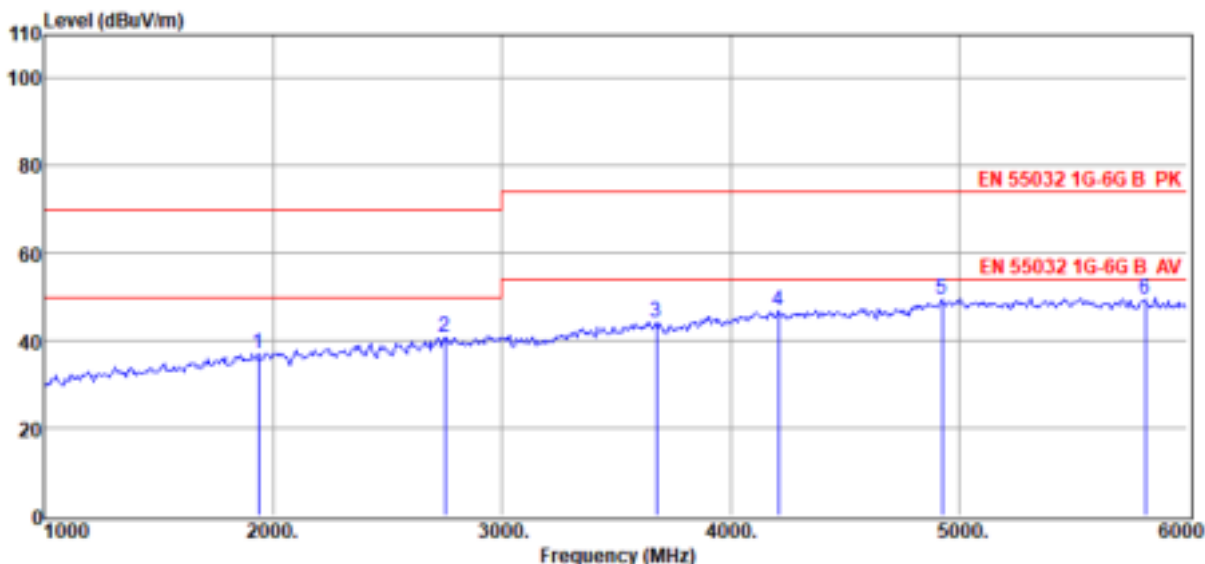

Item (Mark)	Freq. (MHz)	Read Level (dBμV)	Antenna Factor (dB/m)	PRM Factor (dB)	Cable Loss (dB)	Result Level (dBμV/m)	Limit Line (dBμV/m)	Over Limit (dB)	Detector	Polarization
1	1935.00	47.66	27.78	41.82	3.49	37.11	70.00	-32.89	Peak	VERTICAL
2	2750.00	49.78	29.93	42.84	4.11	40.98	70.00	-29.02	Peak	VERTICAL
3	3675.00	50.35	32.17	43.17	4.82	44.17	74.00	-29.83	Peak	VERTICAL
4	4210.00	51.85	33.10	43.09	5.19	47.05	74.00	-26.95	Peak	VERTICAL
5	4925.00	52.39	34.36	42.73	5.61	49.63	74.00	-24.37	Peak	VERTICAL
6	5815.00	51.17	34.89	43.03	6.50	49.53	74.00	-24.47	Peak	VERTICAL

Note: 1. Result Level = Read Level + Antenna Factor + Cable loss - PRM Factor.
 2. If Peak Result complies with AV limit, AV Result is deemed to comply with AV limit.
 3. Test setup: RBW: 1 MHz, VBW: 3 MHz, Sweep time: auto.

TR-4-E-009 Radiated Emission Test Result

Test Site : DDT 3m Chamber 1# **D:\2021 RE 1# Report data\Q21062936-1E\1020 RE-H.EM6**

Test Date : 2021-10-20 **Tested By** : Bote Huang

EUT : Gaming Wireless Headset / USB Wireless Dongle **Model Number** : QUANTUM610 / QUANTUM610TM

Power Supply : AC 240V/50Hz **Test Mode** : Charging mode

Condition : Temp:24.5°C,Humi:55%,Press:101.4kPa **Antenna/Distance** : 2020 HF907/3m/HORIZONTAL

Memo :

Data: 22

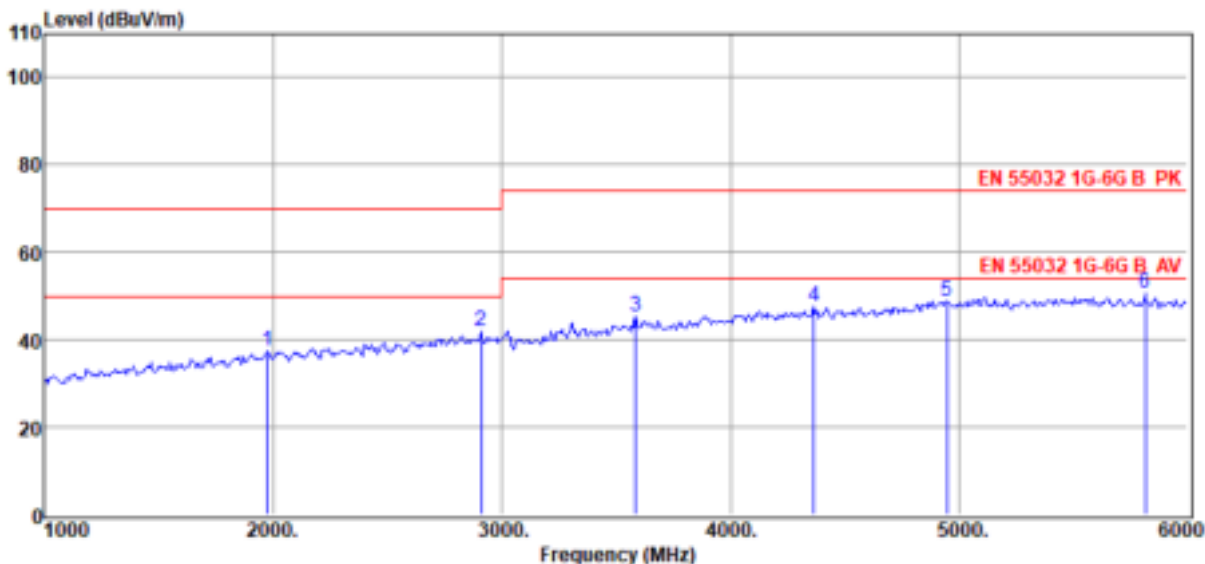

Item (Mark)	Freq. (MHz)	Read Level (dBμV)	Antenna Factor (dB/m)	PRM Factor (dB)	Cable Loss (dB)	Result Level (dBμV/m)	Limit Line (dBμV/m)	Over Limit (dB)	Detector	Polarization
1	1975.00	47.71	27.98	41.87	3.52	37.34	70.00	-32.66	Peak	HORIZONTAL
2	2910.00	50.34	30.37	43.01	4.22	41.92	70.00	-28.08	Peak	HORIZONTAL
3	3585.00	51.66	31.98	43.16	4.75	45.23	74.00	-28.77	Peak	HORIZONTAL
4	4365.00	51.92	33.32	43.00	5.28	47.52	74.00	-26.48	Peak	HORIZONTAL
5	4950.00	51.57	34.40	42.72	5.62	48.87	74.00	-25.13	Peak	HORIZONTAL
6	5815.00	52.17	34.89	43.03	6.50	50.53	74.00	-23.47	Peak	HORIZONTAL

Note: 1. Result Level = Read Level + Antenna Factor + Cable loss - PRM Factor.
 2. If Peak Result complies with AV limit, AV Result is deemed to comply with AV limit.
 3. Test setup: RBW: 1 MHz, VBW: 3 MHz, Sweep time: auto.

TR-4-E-009 Radiated Emission Test Result

Test Site : DDT 3m Chamber 1# **D:\2021 RE 1# Report data\Q21062936-1E\1020 RE-H.EM6**

Test Date : 2021-10-20 **Tested By** : Bote Huang

EUT : Gaming Wireless Headset / USB Wireless Dongle **Model Number** : QUANTUM610 / QUANTUM610TM

Power Supply : AC 240V/50Hz **Test Mode** : Charging + Aux in mode

Condition : Temp:24.5°C,Humi:55%,Press:101.4kPa **Antenna/Distance** : 2020 HF907/3m/HORIZONTAL

Memo :

Data: 23

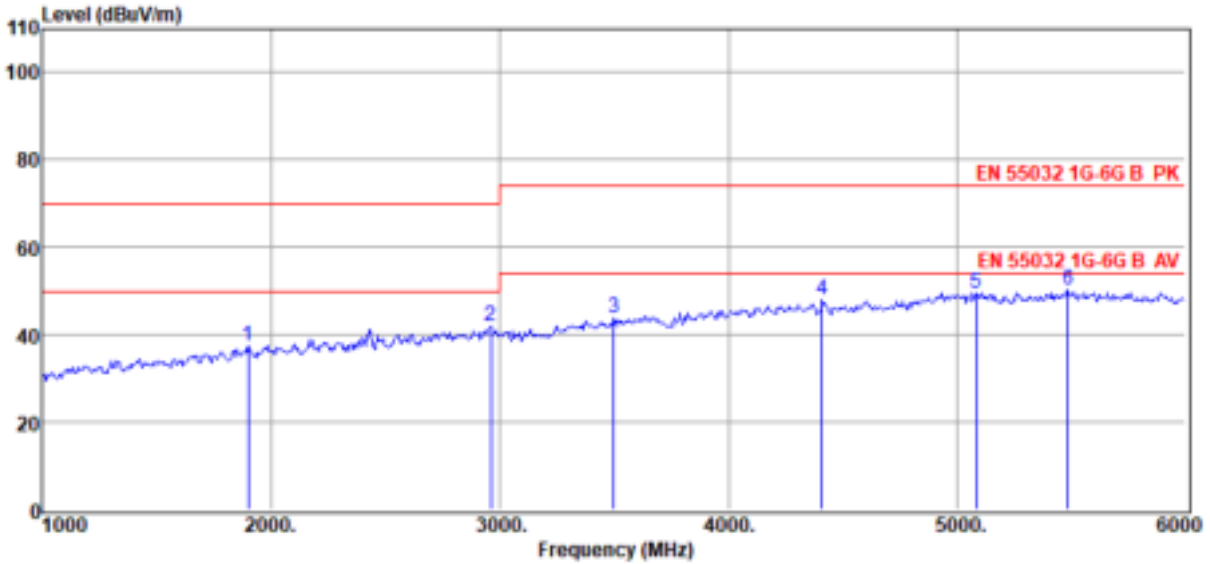

Item (Mark)	Freq. (MHz)	Read Level (dBμV)	Antenna Factor (dB/m)	PRM Factor (dB)	Cable Loss (dB)	Result Level (dBμV/m)	Limit Line (dBμV/m)	Over Limit (dB)	Detector	Polarization
1	1900.00	47.95	27.60	41.78	3.47	37.24	70.00	-32.76	Peak	HORIZONTAL
2	2960.00	50.20	30.50	43.06	4.25	41.89	70.00	-28.11	Peak	HORIZONTAL
3	3500.00	50.57	31.80	43.15	4.69	43.91	74.00	-30.09	Peak	HORIZONTAL
4	4410.00	52.13	33.38	42.98	5.31	47.84	74.00	-26.16	Peak	HORIZONTAL
5	5085.00	52.04	34.54	42.74	5.75	49.59	74.00	-24.41	Peak	HORIZONTAL
6	5485.00	52.30	34.69	42.90	6.17	50.26	74.00	-23.74	Peak	HORIZONTAL

Note: 1. Result Level = Read Level + Antenna Factor + Cable loss - PRM Factor.
 2. If Peak Result complies with AV limit, AV Result is deemed to comply with AV limit.
 3. Test setup: RBW: 1 MHz, VBW: 3 MHz, Sweep time: auto.

TR-4-E-009 Radiated Emission Test Result

Test Site : DDT 3m Chamber 1# **D:\2021 RE 1# Report data\Q21062936-1E\1020 RE-H.EM6**
Test Date : 2021-10-20 **Tested By** : Bote Huang
EUT : Gaming Wireless Headset / USB Wireless Dongle **Model Number** : QUANTUM610 / QUANTUM610TM
Power Supply : AC 240V/50Hz **Test Mode** : Charging + Aux in mode
Condition : Temp:24.5°C,Humi:55%,Press:101.4kPa **Antenna/Distance** : 2020 HF907/3m/VERTICAL

Memo :

Data: 24

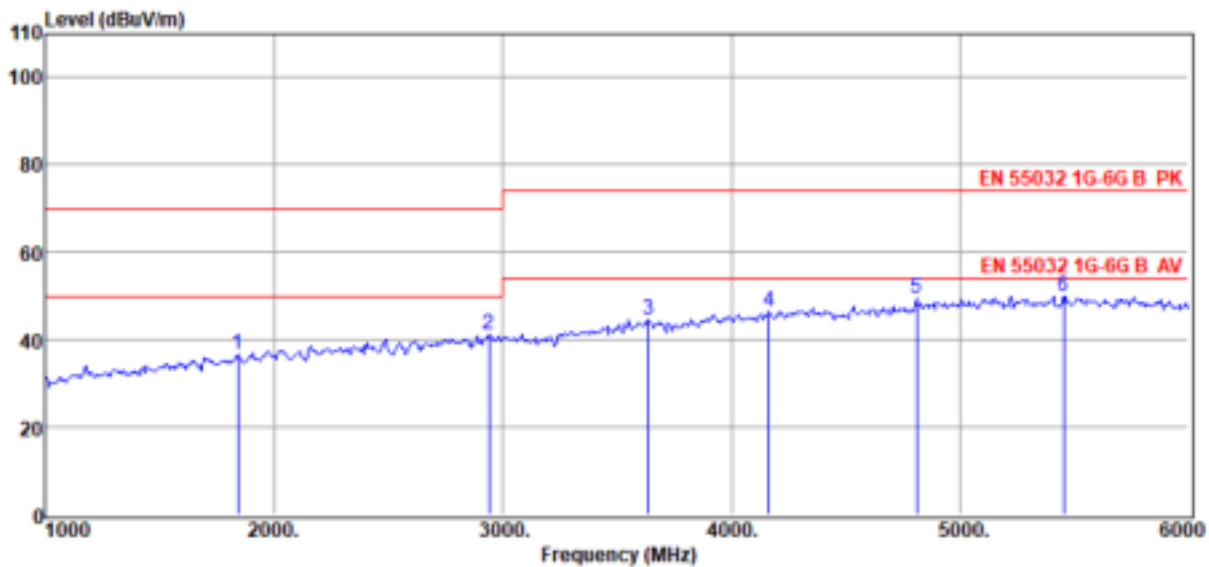

Item (Mark)	Freq. (MHz)	Read Level (dBμV)	Antenna Factor (dB/m)	PRM Factor (dB)	Cable Loss (dB)	Result Level (dBμV/m)	Limit Line (dBμV/m)	Over Limit (dB)	Detector	Polarization
1	1840.00	47.66	27.29	41.71	3.42	36.66	70.00	-33.34	Peak	VERTICAL
2	2940.00	49.40	30.44	43.04	4.23	41.03	70.00	-28.97	Peak	VERTICAL
3	3635.00	50.77	32.08	43.17	4.79	44.47	74.00	-29.53	Peak	VERTICAL
4	4165.00	51.38	33.04	43.11	5.16	46.47	74.00	-27.53	Peak	VERTICAL
5	4810.00	52.80	34.13	42.79	5.55	49.69	74.00	-24.31	Peak	VERTICAL
6	5455.00	52.10	34.68	42.89	6.14	50.03	74.00	-23.97	Peak	VERTICAL

Note: 1. Result Level = Read Level + Antenna Factor + Cable loss - PRM Factor.

2. If Peak Result complies with AV limit, AV Result is deemed to comply with AV limit.

3. Test setup: RBW: 1 MHz, VBW: 3 MHz, Sweep time: auto.

TR-4-E-009 Radiated Emission Test Result

Test Site : DDT 3m Chamber 1# **D:\2021 RE 1# Report data\Q21062936-1E\1020 RE-H.EM6**

Test Date : 2021-10-20 **Tested By** : Bote Huang

EUT : Gaming Wireless Headset / USB Wireless Dongle **Model Number** : QUANTUM610 / QUANTUM610TM

Power Supply : Battery **Test Mode** : Aux in mode

Condition : Temp:24.5°C,Humi:55%,Press:101.4kPa **Antenna/Distance** : 2020 HF907/3m/HORIZONTAL

Memo :

Data: 29

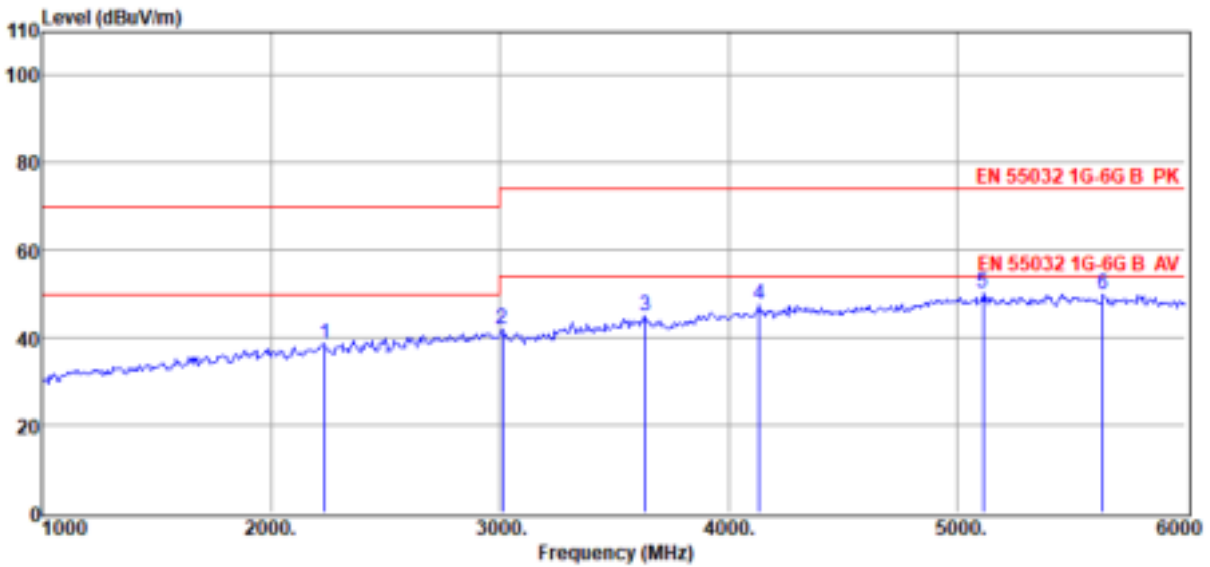

Item (Mark)	Freq. (MHz)	Read Level (dBμV)	Antenna Factor (dB/m)	PRM Factor (dB)	Cable Loss (dB)	Result Level (dBμV/m)	Limit Line (dBμV/m)	Over Limit (dB)	Detector	Polarization
1	2235.00	48.43	28.65	42.23	3.74	38.59	70.00	-31.41	Peak	HORIZONTAL
2	3010.00	50.04	30.63	43.10	4.28	41.85	74.00	-32.15	Peak	HORIZONTAL
3	3635.00	51.24	32.08	43.17	4.79	44.94	74.00	-29.06	Peak	HORIZONTAL
4	4135.00	52.48	33.00	43.13	5.14	47.49	74.00	-26.51	Peak	HORIZONTAL
5	5115.00	52.76	34.55	42.75	5.78	50.34	74.00	-23.66	Peak	HORIZONTAL
6	5640.00	51.61	34.79	42.96	6.33	49.77	74.00	-24.23	Peak	HORIZONTAL

Note: 1. Result Level = Read Level + Antenna Factor + Cable loss - PRM Factor.
 2. If Peak Result complies with AV limit, AV Result is deemed to comply with AV limit.
 3. Test setup: RBW: 1 MHz, VBW: 3 MHz, Sweep time: auto.

TR-4-E-009 Radiated Emission Test Result

Test Site : DDT 3m Chamber 1# **D:\2021 RE 1# Report data\Q21062936-1E\1020 RE-H.EM6**

Test Date : 2021-10-20 **Tested By** : Bote Huang

EUT : Gaming Wireless Headset / USB Wireless Dongle **Model Number** : QUANTUM610 / QUANTUM610TM

Power Supply : Battery **Test Mode** : Aux in mode

Condition : Temp:24.5°C,Humi:55%,Press:101.4kPa **Antenna/Distance** : 2020 HF907/3m/VERTICAL

Memo :

Data: 30

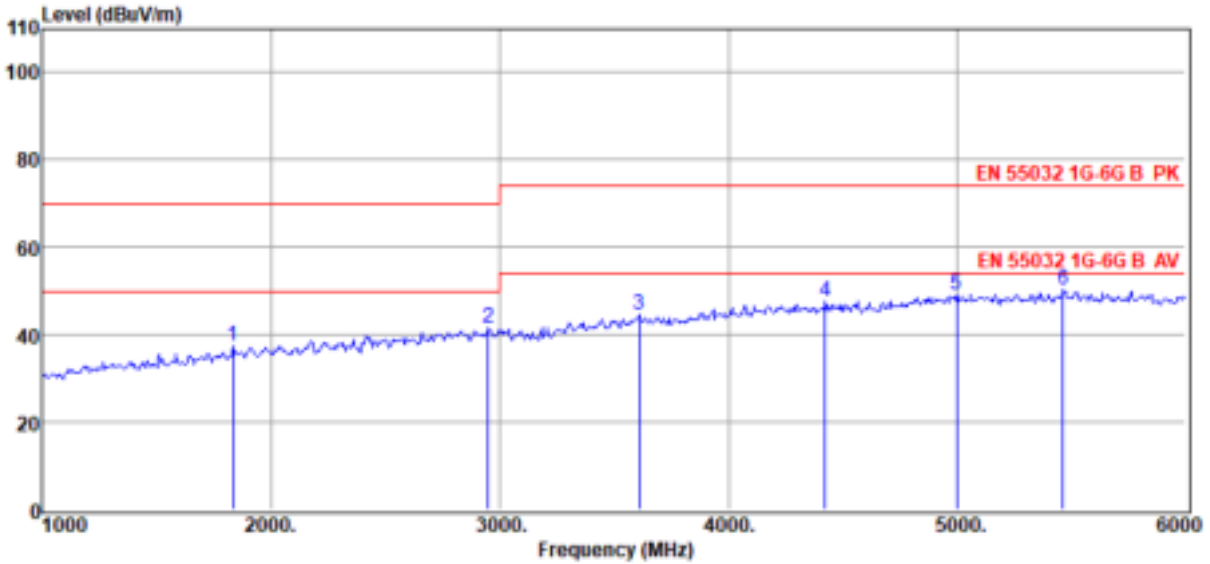

Item (Mark)	Freq. (MHz)	Read Level (dBμV)	Antenna Factor (dB/m)	PRM Factor (dB)	Cable Loss (dB)	Result Level (dBμV/m)	Limit Line (dBμV/m)	Over Limit (dB)	Detector	Polarization
1	1835.00	48.51	27.26	41.70	3.42	37.49	70.00	-32.51	Peak	VERTICAL
2	2950.00	49.78	30.47	43.05	4.24	41.44	70.00	-28.56	Peak	VERTICAL
3	3610.00	50.79	32.03	43.16	4.77	44.43	74.00	-29.57	Peak	VERTICAL
4	4425.00	51.77	33.40	42.97	5.32	47.52	74.00	-26.48	Peak	VERTICAL
5	5000.00	51.82	34.50	42.70	5.65	49.27	74.00	-24.73	Peak	VERTICAL
6	5465.00	52.25	34.69	42.90	6.15	50.19	74.00	-23.81	Peak	VERTICAL

Note: 1. Result Level = Read Level + Antenna Factor + Cable loss - PRM Factor.
 2. If Peak Result complies with AV limit, AV Result is deemed to comply with AV limit.
 3. Test setup: RBW: 1 MHz, VBW: 3 MHz, Sweep time: auto.

TR-4-E-009 Radiated Emission Test Result

Test Site : DDT 3m Chamber 1# **D:\2021 RE 1# Report data\Q21062936-1E\RE-H.EM6**

Test Date : 2021-08-25 **Tested By** : Chunchieh Huang

EUT : Gaming Wireless Headset / USB Wireless Dongle **Model Number** : QUANTUM610 / QUANTUM610TM

Power Supply : AC 240V/50Hz **Test Mode** : Standby mode

Condition : Temp:24.5°C,Humi:55%,Press:101.4kPa **Antenna/Distance** : 2020 HF907/3m/VERTICAL

Memo :

Data: 27

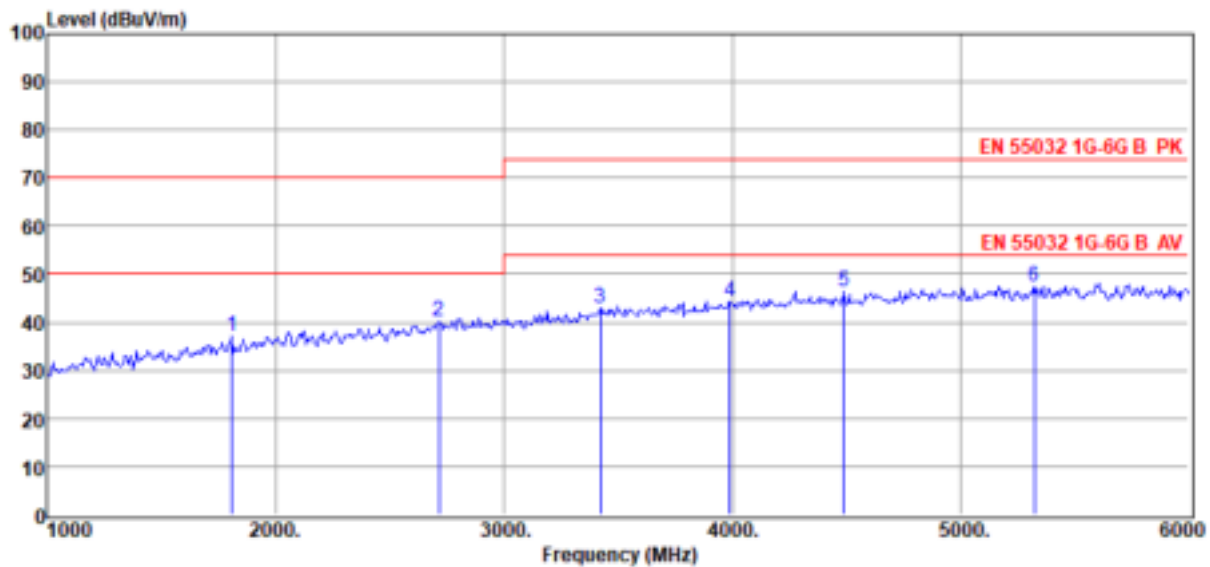

Item (Mark)	Freq. (MHz)	Read Level (dBμV)	Antenna Factor (dB/m)	PRM Factor (dB)	Cable Loss (dB)	Result Level (dBμV/m)	Limit Line (dBμV/m)	Over Limit (dB)	Detector	Polarization
1	1810.00	48.21	27.13	41.67	3.40	37.07	70.00	-32.93	Peak	VERTICAL
2	2715.00	49.12	29.83	42.80	4.09	40.24	70.00	-29.76	Peak	VERTICAL
3	3425.00	49.76	31.63	43.15	4.63	42.87	74.00	-31.13	Peak	VERTICAL
4	3990.00	49.78	32.78	43.20	5.04	44.40	74.00	-29.60	Peak	VERTICAL
5	4490.00	50.43	33.49	42.94	5.36	46.34	74.00	-27.66	Peak	VERTICAL
6	5325.00	49.66	34.63	42.84	6.01	47.46	74.00	-26.54	Peak	VERTICAL

Note: 1. Result Level = Read Level + Antenna Factor + Cable loss - PRM Factor.

2. If Peak Result complies with AV limit, AV Result is deemed to comply with AV limit.

3. Test setup: RBW: 1 MHz, VBW: 3 MHz, Sweep time: auto.

TR-4-E-009 Radiated Emission Test Result

Test Site : DDT 3m Chamber 1# **D:\2021 RE 1# Report data\Q21062936-1E\RE-H.EM6**
Test Date : 2021-08-25 **Tested By** : Chunchieh Huang
EUT : Gaming Wireless Headset / USB Wireless Dongle **Model Number** : QUANTUM610 / QUANTUM610TM
Power Supply : AC 240V/50Hz **Test Mode** : Standby mode
Condition : Temp:24.5°C,Humi:55%,Press:101.4kPa **Antenna/Distance** : 2020 HF907/3m/HORIZONTAL
Memo :

Data: 28

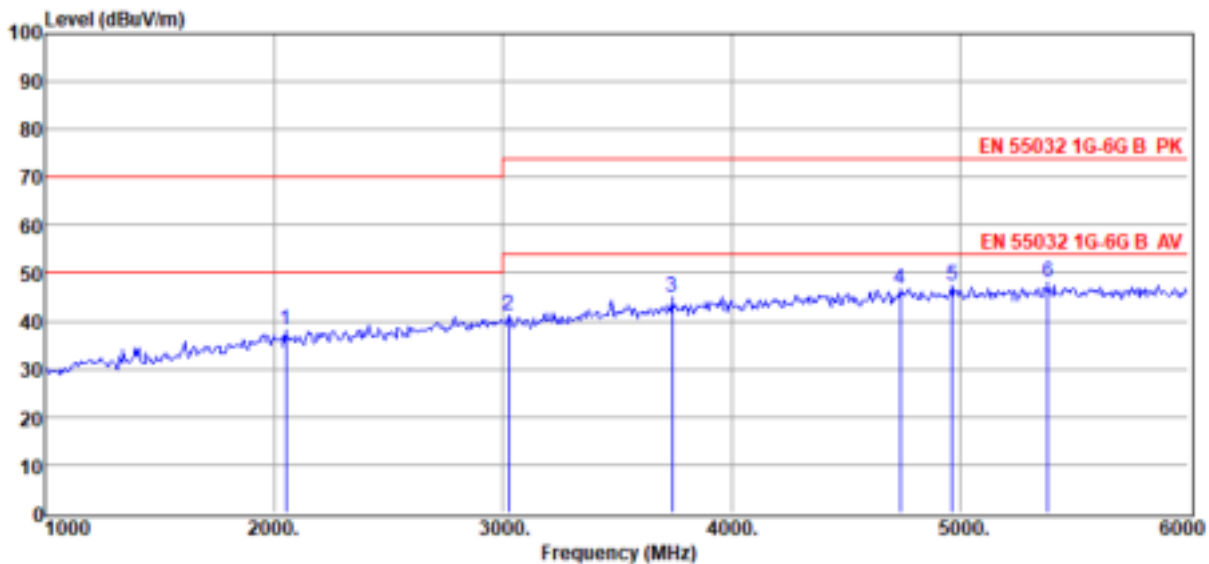

Item (Mark)	Freq. (MHz)	Read Level (dBμV)	Antenna Factor (dB/m)	PRM Factor (dB)	Cable Loss (dB)	Result Level (dBμV/m)	Limit Line (dBμV/m)	Over Limit (dB)	Detector	Polarization
1	2050.00	48.36	28.22	41.97	3.58	38.19	70.00	-31.81	Peak	HORIZONTAL
2	3025.00	49.26	30.66	43.10	4.29	41.11	74.00	-32.89	Peak	HORIZONTAL
3	3740.00	50.90	32.30	43.18	4.87	44.89	74.00	-29.11	Peak	HORIZONTAL
4	4740.00	50.00	33.99	42.82	5.51	46.68	74.00	-27.32	Peak	HORIZONTAL
5	4965.00	50.05	34.43	42.72	5.63	47.39	74.00	-26.61	Peak	HORIZONTAL
6	5385.00	50.33	34.66	42.86	6.07	48.20	74.00	-25.80	Peak	HORIZONTAL

Note: 1. Result Level = Read Level + Antenna Factor + Cable loss - PRM Factor.

2. If Peak Result complies with AV limit, AV Result is deemed to comply with AV limit.

3. Test setup: RBW: 1 MHz, VBW: 3 MHz, Sweep time: auto.

4.7. Test photo

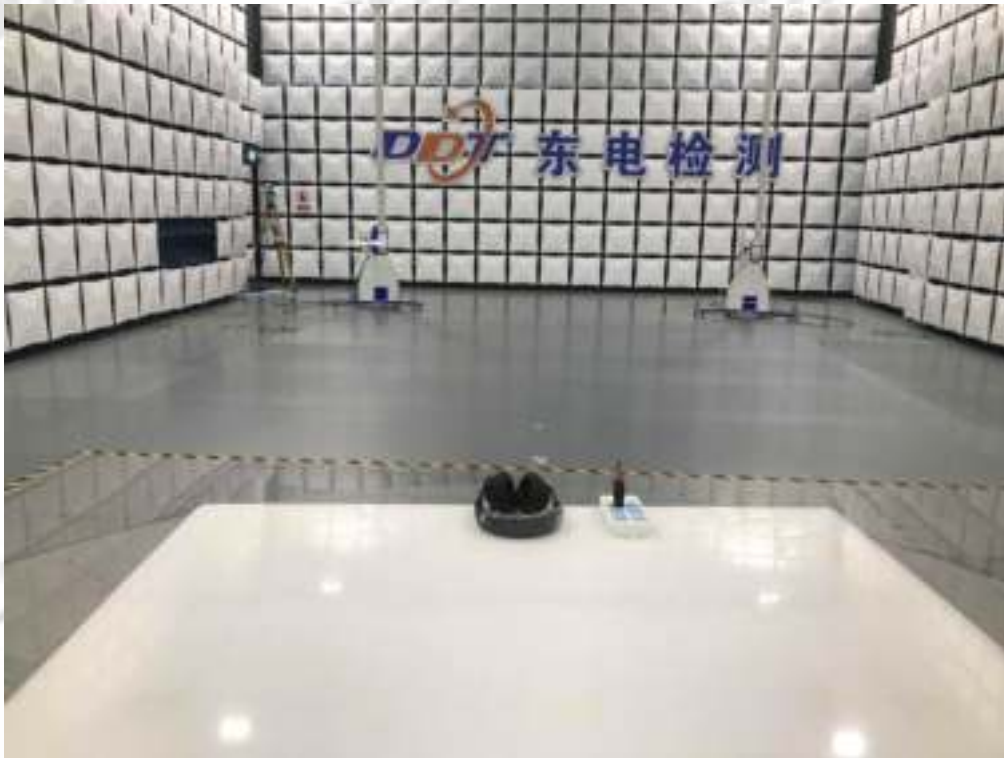



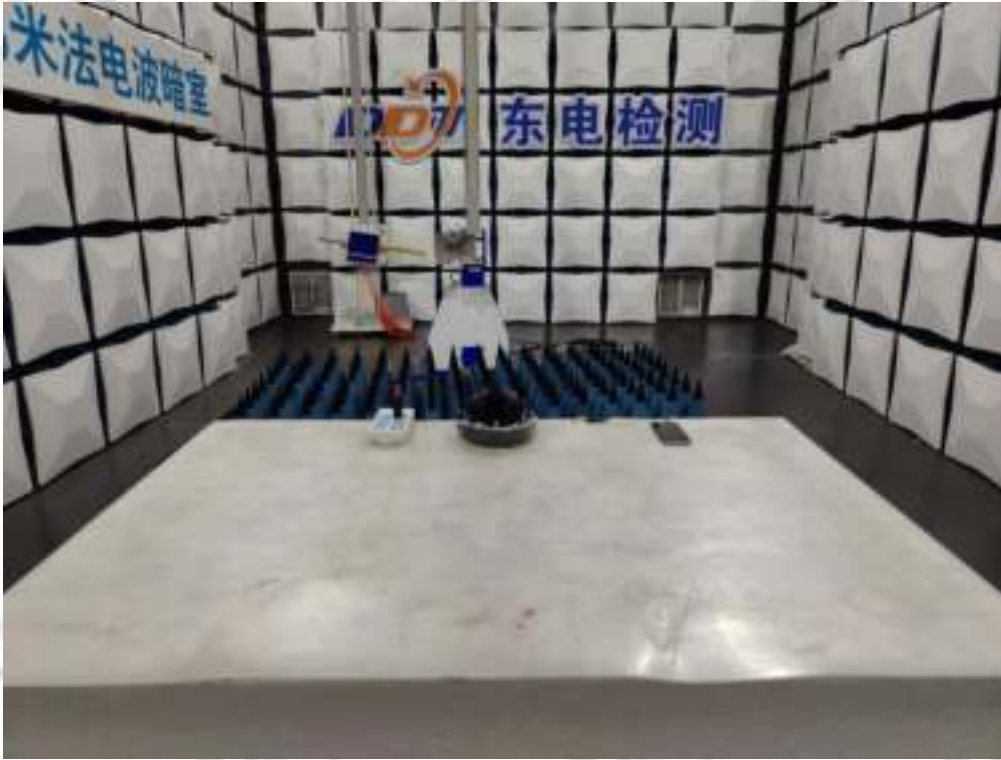

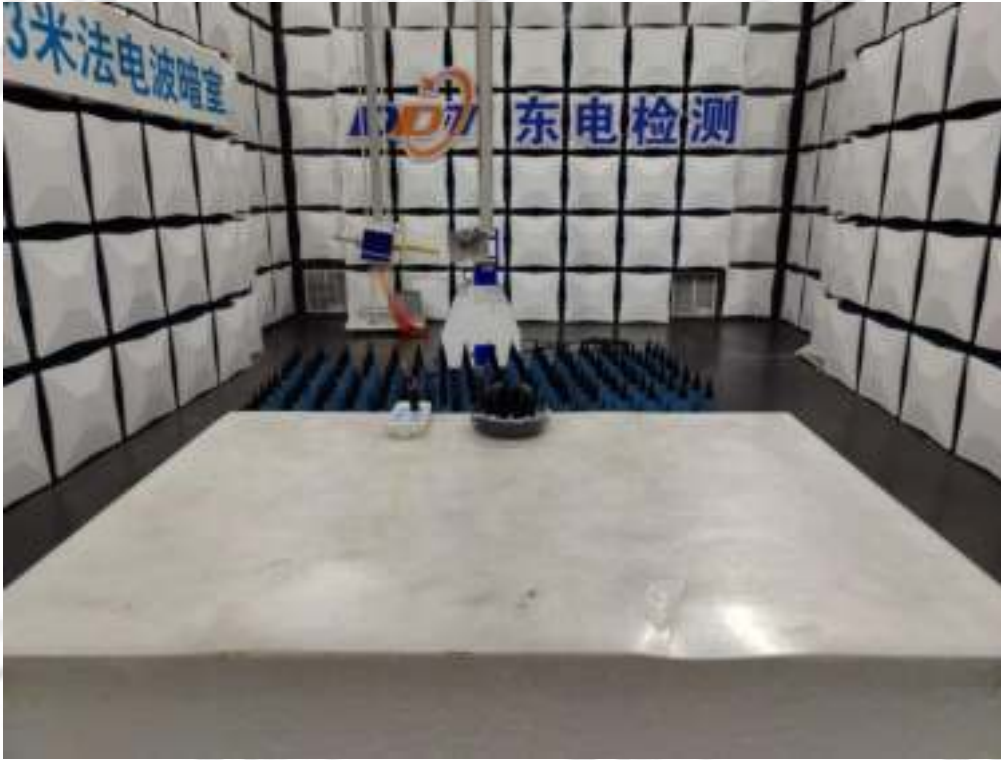

5. Harmonic Current and Voltage Fluctuations & Flicker Test Report

5.1. Test equipment

Equipment	Manufacturer	Model No.	Serial No.	Last Cal.	Cal. Interval
HARMONICS and Voltage fluctuation and flicker tester	EMC-PARTNER	HAR1000-1P	HAP1000-1P230V-0205	Jul. 06, 2021	1Year
Test Software	EMC-PARTNER	Harmonics-1000	4.19	N/A	N/A

5.2. Block diagram of test setup

Table-top device

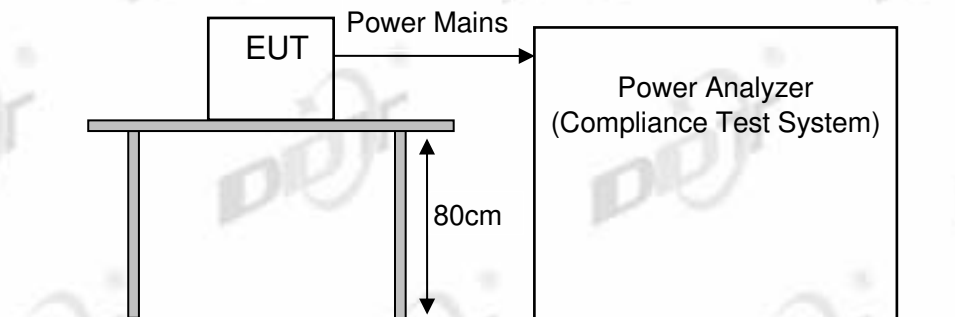

Floor-standing device

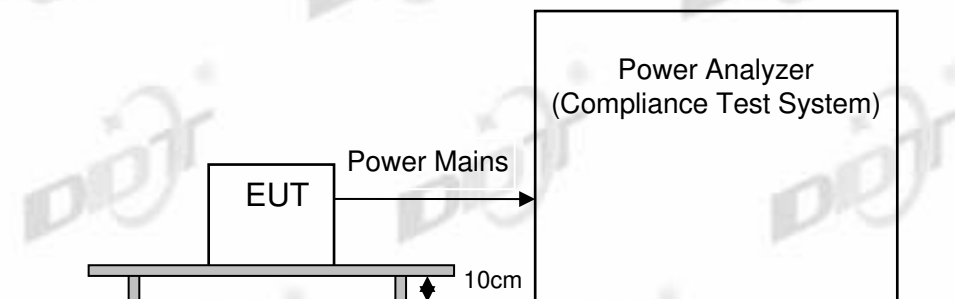

5.3. Harmonic current limits

Classification of equipment: Class A: audio equipment. Class D: equipment having a specified power less than or equal to 600 W, of the following types: personal computers and personal computer monitors; television receivers.

For Class A equipment

Harmonic order(n)	Maximum permissible harmonic current (A)
Odd harmonics	
3	2.30
5	1.14
7	0.77
9	0.40

11	0.33
13	0.21
$15 \leq n \leq 39$	$0.15 * 15/n$
Even harmonics	
3	1.08
4	0.43
6	0.30
$8 \leq n \leq 40$	$0.23 * 8/n$
Note: λ is the circuit power factor.	

For Class D equipment

Harmonic order(n)	Maximum permissible harmonic current per watt (mA/W)	Maximum permissible harmonic current (A)
3	3.4	2.30
5	1.9	1.14
7	1.0	0.77
9	0.5	0.40
11	0.35	0.33
$13 \leq n \leq 39$ (odd harmonic only)	$3.85/n$	$0.21 * 13/n$

5.4. Voltage fluctuations & flicker Limit

Test Item	Limit	Note
Pst	1.0	Pst means Short-term flicker indicator
Plt	0.65	Plt means long-term flicker indicator
Tdt	0.5	Tdt means maximum time that dt exceeds 3.3%
dmax(%)	4%	dmax means maximum relative voltage change.
dc(%)	3.3%	dc means relative steady-state voltage change.

5.5. Assistant equipment used for test

Assistant equipment	Manufacturer	Model number	Description	other
Adapter	SAMSUNG	EP-TA200	N/A	Input: 100-240~, 50/60Hz, 0.5A; Output: 9V/1.67A or 5V/2A
Phone	SAMSUNG	SM-G6200	POWM4001045	N/A

5.6. Test procedure

For Harmonic current test:

The EUT was placed on the top of a wooden table 0.8 meters above the ground and operated to produce the maximum harmonic components under normal operating conditions for each successive harmonic component in turn. The correspondent test program of test instrument to measure the current harmonics emanated from EUT is chosen. The measure time shall be not less than the necessary for the EUT to be exercised.

For Voltage fluctuations & flicker

The EUT was placed on the top of a wooden table 0.8 meters above the ground and operated to produce the most unfavorable sequence of voltage changes under normal conditions during the flick measurement; the measure time shall include that part of whole operation changes. The observation period for short-term flicker indicator is 10 minutes and the observation period for long-term flicker indicator is 2 hours.

5.7. Test result

Harmonic current test result:

N/A: Not applicable

Note: According to IEC 61000-3-2 Clause 7, this product belongs to exceptions of Clause 7 or Annex C. limits are not specified in this standard.

**Voltage fluctuations & flicker test result:
Flicker Emission - IEC 61000-3-3 , EN 61000-3-3**

Comply: IEC 61000-3-2 Ed.3.0 + Ed.4.0 - IEC 61000-4-7 Ed.2.0
Flicker Emission IEC 61000-4-15 for 230V/50Hz

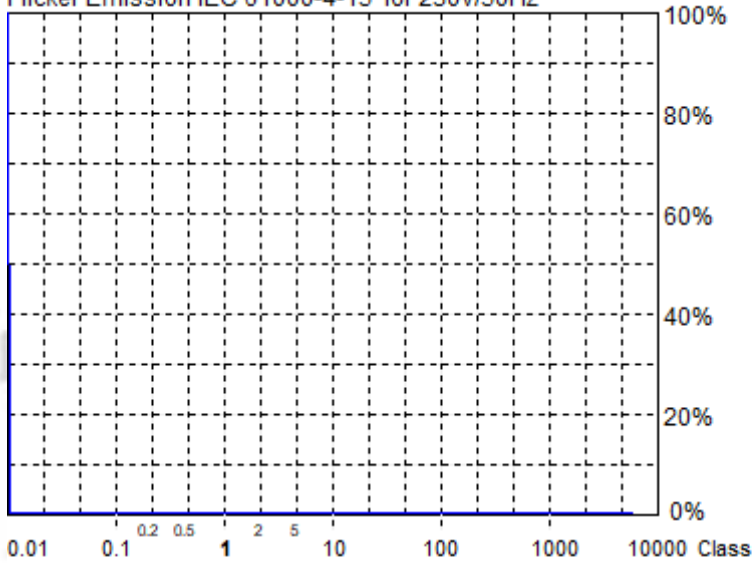

Actual Flicker (Fli):	0.00
Short-term Flicker (Pst):	0.07
Limit (Pst):	1.00
Long-term Flicker (Plt):	0.07
Limit (Plt):	0.65
Maximum Relative Volt. Change (dmax):	0.00%
Limit (dmax):	4.00%
Relative Steady-state Voltage Change (dc):	0.00%
Limit (dc):	3.30%
Tmax 3.30% (dt):	0.00ms
Limit (dt>Lim):	500ms

Flicker Emission - IEC 61000-3-3 , EN 61000-3-3

2021/10/11 15:14:29

Urms = 231.7 V P = 2.111 W
Irms = 0.019 A pf = 0.478

Range: 0.25 A
V-nom: 230 V
TestTime: 10 min (100%)

Test completed, Result: PASSED

HAR-1000 EMC-Partner

Full Bar : Actual Values
Empty Bar : Maximum Values
Circles : Average Values
Blue : Current , Green : Voltage , Red : Failed

Operator Elosky Liu
Unit Gaming Wireless Headset / USB Wireless Dongle
Serial Number QUANTUM610 / QUANTUM610TM
Test Mode Charging mode

Urms = 231.7V Freq = 50.000 Range: 0.25 A
Irms = 0.019A lpk = 0.114A cf = 5.994
P = 2.111W S = 4.412VA pf = 0.478

Test - Time : 1 x 10min = 10min (100 %)

LIN (Line Impedance Network) : L: 0.24ohm +j0.15ohm N: 0.16ohm +j0.10ohm

Limits : Plt : 0.65 Pst : 1.00
dmax : 4.00 % dc : 3.30 %
dtLim: 3.30 % dt>Lim: 500ms

Test completed, Result: PASSED

	dmax
	[%]
1	0.000

Flicker Emission - IEC 61000-3-3 , EN 61000-3-3

Comply: IEC 61000-3-2 Ed.3.0 + Ed.4.0 - IEC 61000-4-7 Ed.2.0
 Flicker Emission IEC 61000-4-15 for 230V/50Hz

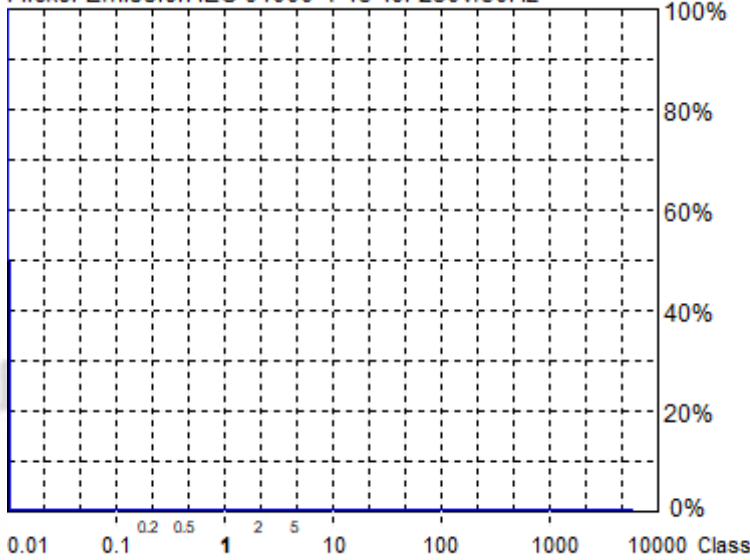

Actual Flicker (Fli):	0.00
Short-term Flicker (Pst):	0.07
Limit (Pst):	1.00
Long-term Flicker (Plt):	0.07
Limit (Plt):	0.65
Maximum Relative Volt. Change (dmax):	0.00%
Limit (dmax):	4.00%
Relative Steady-state Voltage Change (dc):	0.00%
Limit (dc):	3.30%
Tmax 3.30% (dt):	0.00ms
Limit (dt>Lim):	500ms

Flicker Emission - IEC 61000-3-3 , EN 61000-3-3

2021/10/11 15:14:29

Urms = 231.7 V P = 2.111 W
 Irms = 0.019 A pf = 0.478

Range: 0.25 A
 V-nom: 230 V
 TestTime: 10 min (100%)

Test completed, Result: PASSED

HAR-1000 EMC-Partner

Full Bar : Actual Values
 Empty Bar : Maximum Values
 Circles : Average Values
 Blue : Current , Green : Voltage , Red : Failed

Operator Elosky Liu
 Unit Gaming Wireless Headset / USB Wireless Dongle
 Serial Number QUANTUM610 / QUANTUM610TM
 Test Mode Charging + Aux in mode

Urms = 231.7V Freq = 50.000 Range: 0.25 A
 Irms = 0.019A Ipk = 0.114A cf = 6.006
 P = 2.104W S = 4.412VA pf = 0.477

Test - Time : 1 x 10min = 10min (100 %)

LIN (Line Impedance Network) : L: 0.24ohm +j0.15ohm N: 0.16ohm +j0.10ohm

Limits : Plt : 0.65 Pst : 1.00
 dmax : 4.00 % dc : 3.30 %
 dtLim: 3.30 % dt>Lim: 500ms

Test completed, Result: PASSED

	dmax
	[%]
1	0.000

5.8. Test photo



6. Electrostatic Discharge Test Report

6.1. Test equipment

Equipment	Manufacturer	Model No.	Serial No.	Last Cal.	Cal. Interval
<input checked="" type="checkbox"/> ESD Generator	TESEQ	NSG 437	981	Sep. 02, 2021	1 Year
<input type="checkbox"/> ESD Generator	TESEQ	NSG 438	1127	Jul. 17, 2021	1 Year

6.2. Block diagram of test setup

Table-top equipment

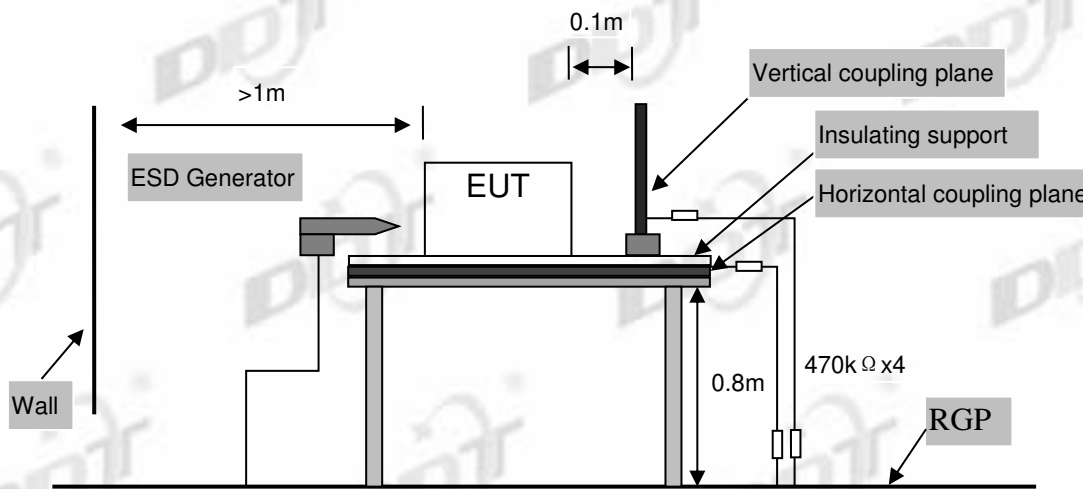

Floor-standing equipment

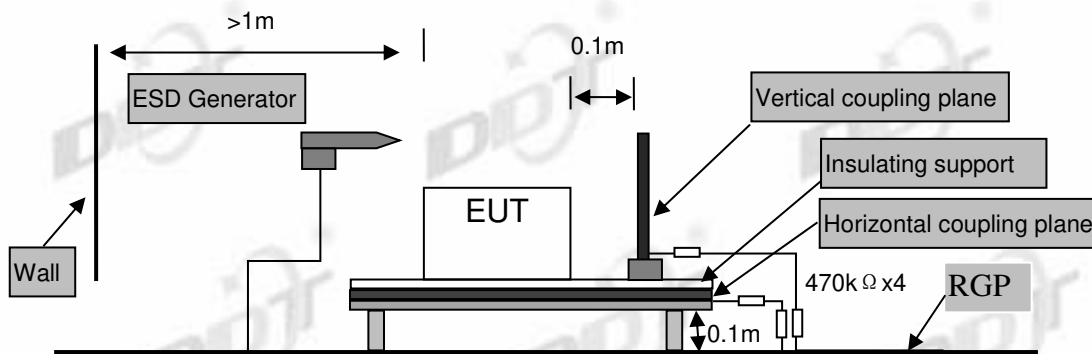

6.3. Test levels and performance criterion

Test Level		Performance Criteria
Air Discharge	±2kV, ±4kV and ±8kV	B
Contact Discharge	±4kV	

Performance criteria B description: During the test, degradation of performance is allowed. However, no change of operating state or stored data is allowed to persist after the test. After the test, the EUT shall continue to operate as intended without operator intervention. No degradation of performance or loss of function is allowed, after the application of the phenomena below a performance level specified by the manufacturer, when the EUT is used as intended.

6.4. Assistant equipment used for test

Assistant equipment	Manufacturer	Model number	Description	other
Adapter	SAMSUNG	EP-TA200	N/A	Input: 100-240~, 50/60Hz, 0.5A; Output: 9V/1.67A or 5V/2A
Phone	SAMSUNG	SM-G9500	R28M63VA52Z	N/A

6.5. Test procedure

Air Discharge:

The test was applied on non-conductive surfaces of EUT. The round discharge tip of the discharge electrode was approached as fast as possible to touch the EUT. After each discharge, the discharge electrode was removed from the EUT. The generator was re-triggered for a new single discharge and repeated 20 times for each pre-selected test point. This procedure was repeated until all the air discharge completed.

Contact Discharge:

All the procedure was same as air discharge. Except that the generator was re-triggered for a new single discharge. The tip of the discharge electrode was touching the EUT before the discharge switch was operated.

Indirect discharge for horizontal coupling plane:

At least 20 single discharges were applied to the horizontal coupling plane, at points on each side of the EUT. The discharge electrode positions vertically at a distance of 0.1m from the EUT and with the discharge electrode touching the coupling plane.

Indirect discharge for vertical coupling plane:

At least 20 single discharges were applied to the center of one vertical edge of the coupling plane. The coupling plane, of dimensions 0.5m X 0.5m, was placed parallel to, and positioned at a distance of 0.1m from the EUT. Discharges were applied to the coupling plane, with this plane in sufficient different positions that the four faces of the EUT are completely illuminated.

6.6. Test result

Test Site: DDT <input checked="" type="checkbox"/> 1# <input type="checkbox"/> 2# Electrostatic Discharge Room						
Ambient Condition: <u>22.8</u> °C, <u>49.6</u> %RH, <u>101.4</u> kPa						
Test Power supply: <input checked="" type="checkbox"/> AC 230V/50Hz, <input checked="" type="checkbox"/> Battery <input type="checkbox"/> DC:						
According Standard: <input checked="" type="checkbox"/> EN61000-4-2:2009, <input checked="" type="checkbox"/> EN55035, <input type="checkbox"/> other:						
Test Times: 20 times at each point for contact discharge; 20 times at each point for air discharge. <input checked="" type="checkbox"/> 1 <input type="checkbox"/> 5 <input type="checkbox"/> 10 seconds interval for each discharge.						
Operation Mode	Type of discharge	Test Level	Test Point	Performance		Result (Pass/Fail)
				Required	Observation	
Charging mode	Contact to EUT	±4kV	/	B	/	/
	Contact to Coupling Planes	±4kV	Coupling Planes	B	A	Pass
	Air	±2kV, ±4kV, and ±8kV	1,2,3,4,5,6,7,8	B	A	Pass
Charging + Aux in mode	Contact to EUT	±4kV	/	B	/	/
	Contact to Coupling Planes	±4kV	Coupling Planes	B	A	Pass
	Air	±2kV, ±4kV, and ±8kV	1,2,3,4,5,6,7,8	B	A	Pass
Aux in mode	Contact to EUT	±4kV	1	B	/	/
	Contact to Coupling Planes	±4kV	Coupling Planes	B	A	Pass
	Air	±2kV, ±4kV, and ±8kV	2,3,4,5,6,7,8	B	A	Pass
Standby mode	Contact to EUT	±4kV	/	B	/	/
	Contact to Coupling Planes	±4kV	Coupling Planes	B	A	Pass
	Air	±2kV, ±4kV, and ±8kV	1,2,3,4,5,6,7,8	B	A	Pass
Test Point:						
No.	Description	No.	Description	No.	Description	
1	Type-C port	5	Key	9	Dongle Gap	
2	Aux in port	6	Knob	10	USB port	
3	LED	7	Gap	11	/	
4	MIC	8	Trumpet	12	/	
Observation Description:						
A: Operation as intend, no loss of function during test and after test.						
Test engineer: Elosky Liu				Test date: Oct. 25, 2021		

Photo of ESD point on EUT



6.7. Test photo





7. Continuous Radio Frequency Disturbances

7.1. Test equipment

Equipment	Manufacturer	Model No.	Serial No.	Last Cal.	Cal. Interval
Signal Generator	Agilent	N5172B	MY53050018	Sep. 02, 2021	1 Year
Amplifier	Wonder	HPA80M1000M500	001	Jul. 06, 2021	1 Year
Amplifier	Wonder	HPA1000M2500M300	002	Jul. 06, 2021	1 Year
Amplifier	Wonder	HPA2500M6000M200	003	Jul. 06, 2021	1 Year
Powermeter	Agilent	E4417A	MY45100568	Sep. 23, 2021	1 Year
Powersensor	Agilent	E9323	MY44420907	Sep. 23, 2021	1 Year
Powersensor	Agilent	E9323	US40410405	Sep. 23, 2021	1 Year
Log-periodic antenna	Schwarzbeck	STLP 9149	587	Sep. 23, 2021	1 Year
Log-periodic antenna	Schwarzbeck	STLP 9128D special	090	Sep. 23, 2021	1 Year
Field strength probe	PMM	EP-601	611WX80209	Oct. 21, 2020	1 Year
MXU Vector Generator	Agilent	N5182A	MY47420276	Sep. 02, 2021	1 Year
Accessory Equipment used for test					
Audio Analyzer	R&S	UPL16	100167	Jun. 10, 2021	1 Year
MXG Vector Generator	Agilent	N5182A	MY47420276	Sep. 02, 2021	1 Year
EXG Vector Signal Generator	Agilent	N5172B	MY53050018	Sep. 02, 2021	1 Year
Digital Video test software	Keysight	N7623B	Version 8.0.0.1	N/A	N/A
Microphone	Supwerlux	ECM888B	E888B5A0298	N/A	N/A
Artificial Ear	AIHUA	Type0213	2018022701	N/A	N/A
Artificial Ear	AIHUA	Type0212	2017102603	N/A	N/A
Note: N/A means not applicable.					

7.2. Block diagram of test setup

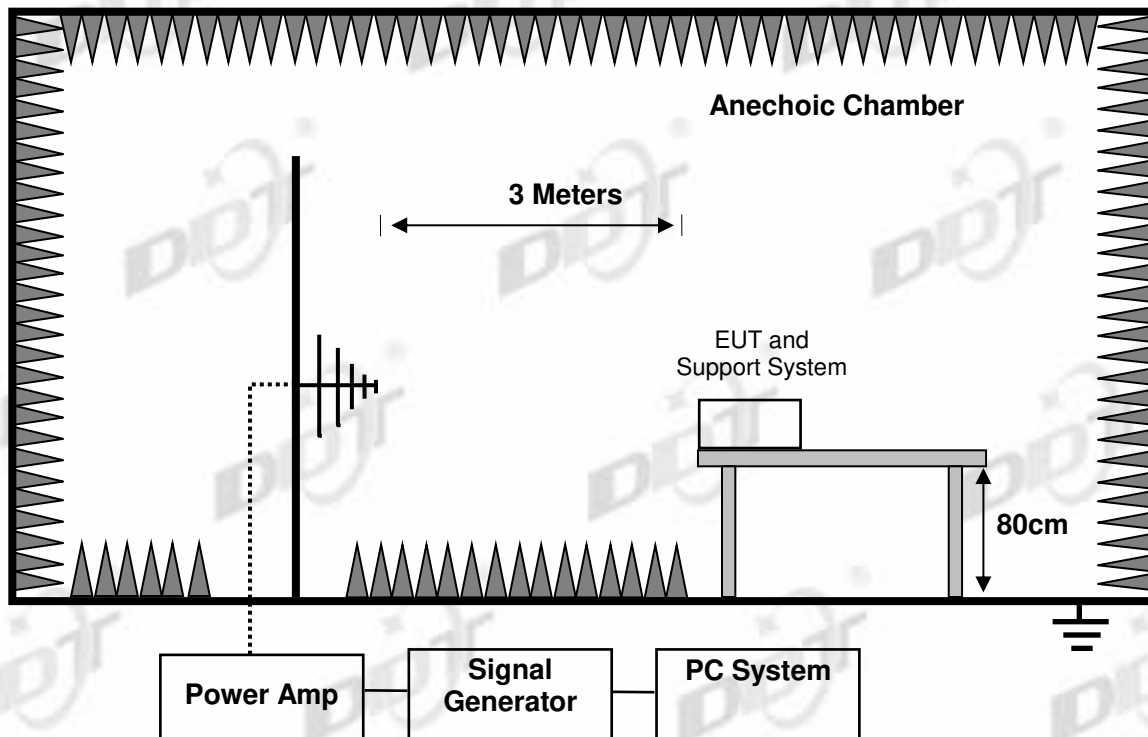

7.3. Test levels and performance criterion

Swept frequency test		Performance Criteria
Frequency (MHz)	80 to 1000	A
Field Strength	3V/m rms voltage level of the unmodulated signal	
Modulation	AM modulated to a depth of 80% by a sine wave of ☒ 1 kHz, ☐ 400 Hz (note 1)	
Step Size	1% increments	
Dwell time	≤5 Sec.	

Spot frequency test		Performance Criteria
Frequency (MHz)	1800, 2600, 3500, 5000	A
Field Strength	3V/m rms voltage level of the unmodulated signal	
Modulation	AM modulated to a depth of 80% by a sine wave of ☒ 1 kHz, ☐ 400 Hz (note 1)	
Dwell time	≤5 Sec.	

Note 1: The 1 kHz modulation may be replaced by a different audio modulation frequency more appropriate for a given EUT if, for example, 1 kHz is not within the operating audio range of the EUT.

Performance criteria A description for devices with the audio output function: The measured acoustic interference ratio and/or the measured electrical interference ratio during the test shall be -20 dB or better.

For equipment with audio output function:

- The acoustic measurement method was selected according to clause G6.4.1 of EN 55035.
 The electrical measurement method was selected according to clause G6.4.2 of EN 55035.
 Performance criteria A for devices with the telephony function.

Frequency range MHz	Acoustic or electrical interference ratio	Equivalent direct measurement		
		dB(SPL)	Digital dBm0	Analogue dBm0
80 to 1000	-0 dB	75	-30	-30

Note: At the step in the frequency range, the lower limit shall be applied.
 The interference ratio (electrical or acoustic) shall meet the limits in column 2; or,
 The acoustic level of the demodulated audio shall be less than the limits in column 3; or
 The digitally coded level of demodulated audio shall be less than limits in column 4; or,
 The analogue level of the demodulated audio shall be less than the limits in column 5.

Performance criteria A description for other devices: During and after the test the EUT shall continue to operate as intended without operator intervention. No degradation of performance or loss of function is allowed below a minimum performance level specified by the manufacturer when the EUT is used as intended.

7.4. Assistant equipment used for test

Assistant equipment	Manufacturer	Model number	Description	other
Adapter	SAMSUNG	EP-TA200	N/A	Input: 100-240~, 50/60Hz, 0.5A; Output: 9V/1.67A or 5V/2A
Phone	SAMSUNG	SM-G9500	R28M63VA52Z	N/A

7.5. Test procedure

The field sensor is placed on the EUT table (0.8 meter above the ground) which is 3 meters away from the transmitting antenna. Through the signal generator, power amplifier and transmitting antenna to produce a uniformity field strength (3V/m measured by field sensor) around the EUT table from frequency range specified and records the signal generator's output level at the same time for whole measured frequency range. Then, put EUT and its simulators on the EUT turn table and keep them 3 meters away from the transmitting antenna which is mounted on an antenna tower and fixes at 1 meter height above the ground. Using the recorded signal generator's output level to measure the EUT from frequency range specified and both horizontal & vertical polarization of antenna must be set and measured. Each of the four sides of EUT must be faced this transmitting antenna and measures individually.

7.6. Test result

Test Site: DDT 4# Chamber						
Ambient Condition: <u>23.5</u> °C, <u>45.5</u> %RH, <u>101.4</u> kPa						
Test Power supply: <input checked="" type="checkbox"/> AC 230V/50Hz, <input checked="" type="checkbox"/> Battery <input type="checkbox"/> DC:						
According Standard: <input checked="" type="checkbox"/> EN 61000-4-3:2006/A2:2010, <input checked="" type="checkbox"/> EN 55035, <input type="checkbox"/> other:						
Field Strength: <input checked="" type="checkbox"/> 3V/m <input type="checkbox"/> 10V/m <input type="checkbox"/> Other: Dwell time: <input checked="" type="checkbox"/> 1s <input type="checkbox"/> other:						
Frequency Range: <input checked="" type="checkbox"/> 80 MHz---1 GHz; <input checked="" type="checkbox"/> 1800 MHz, 2600 MHz, 3500 MHz, 5000 MHz <input type="checkbox"/> other:						
Modulation: <input type="checkbox"/> None <input checked="" type="checkbox"/> AM <input checked="" type="checkbox"/> 1 kHz <input type="checkbox"/> 400 Hz Modulation depth: <input checked="" type="checkbox"/> 80% <input type="checkbox"/> other:						
Operation Mode	EUT Position towards antenna	Antenna: Horizontal		Antenna: Vertical		Result (Pass/Fail)
		Required	Observation	Required	Observation	
Charging mode	Front	A	A	A	A	Pass
	Right	A	A	A	A	Pass
	Rear	A	A	A	A	Pass
	Left	A	A	A	A	Pass
Charging + Aux in mode	Front	A	A	A	A	Pass
	Right	A	A	A	A	Pass
	Rear	A	A	A	A	Pass
	Left	A	A	A	A	Pass
Aux in mode	Front	A	A	A	A	Pass
	Right	A	A	A	A	Pass
	Rear	A	A	A	A	Pass
	Left	A	A	A	A	Pass
Standby mode	Front	A	A	A	A	Pass
	Right	A	A	A	A	Pass
	Rear	A	A	A	A	Pass
	Left	A	A	A	A	Pass
Charging + Aux in mode Acoustic interference ratio= <u>-45.884</u> dB≤-20dB.						
Aux in mode Acoustic interference ratio= <u>-50.385</u> dB≤-20dB.						
Note 1: this row only for the device with audio output function.						
Note 2: this device without the telephony function.						
Observation Description: A: Operation as intend, no loss of function during test and after test.						
Test Engineer: Telamon Chen				Test Date: Oct. 26, 2021		

The worst data results are summarized as follows:
Charging + Aux in mode

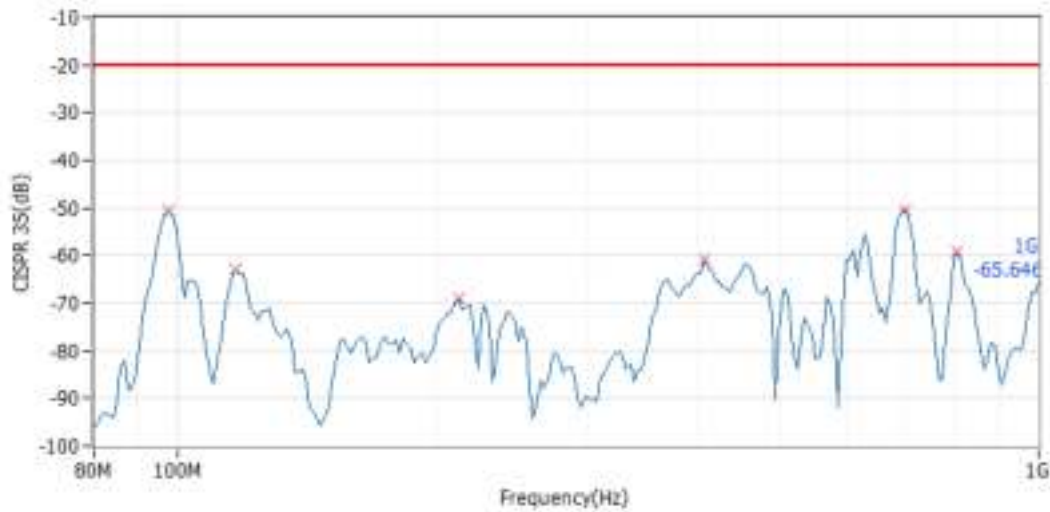

Frequency	UpperLimit	Lowerlimit	Value	Title
804.727714 MHz	-20dB	-	-59.308dB	CISPR 35
700.083305 MHz	-20dB	-	-50.452dB	CISPR 35
409.068009 MHz	-20dB	-	-60.733dB	CISPR 35
116.762202 MHz	-20dB	-	-63.043dB	CISPR 35
212.121551 MHz	-20dB	-	-69.108dB	CISPR 35
97.615214 MHz	-20dB	-	-50.385dB	CISPR 35

Aux in mode

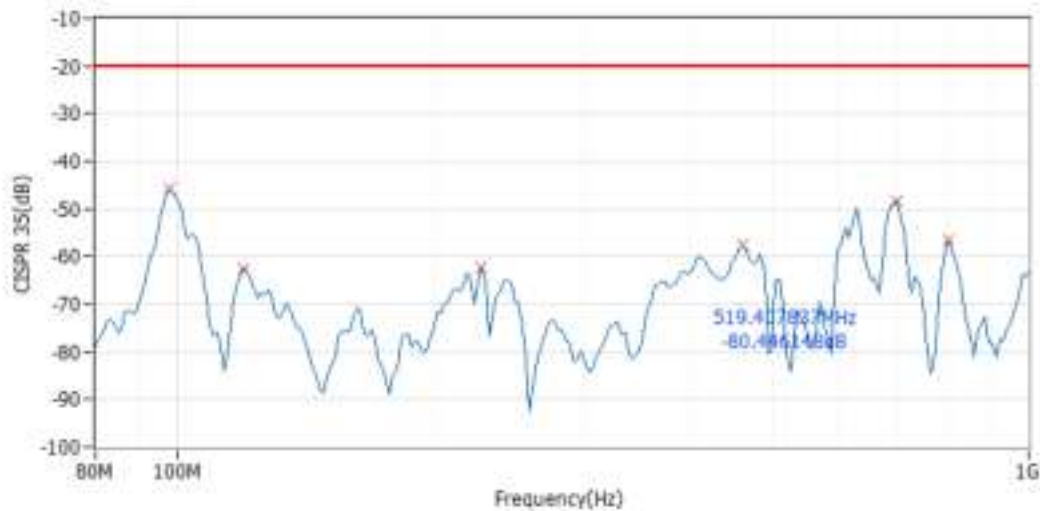

Frequency	UpperLimit	Lowerlimit	Value	Title
804.727714 MHz	-20dB	-	-56.671dB	CISPR 35
700.083305 MHz	-20dB	-	-48.316dB	CISPR 35
460.948077 MHz	-20dB	-	-57.686dB	CISPR 35
227.423017 MHz	-20dB	-	-62.116dB	CISPR 35
119.109124 MHz	-20dB	-	-62.446dB	CISPR 35
97.615214 MHz	-20dB	-	-45.884dB	CISPR 35

7.7. Test photo

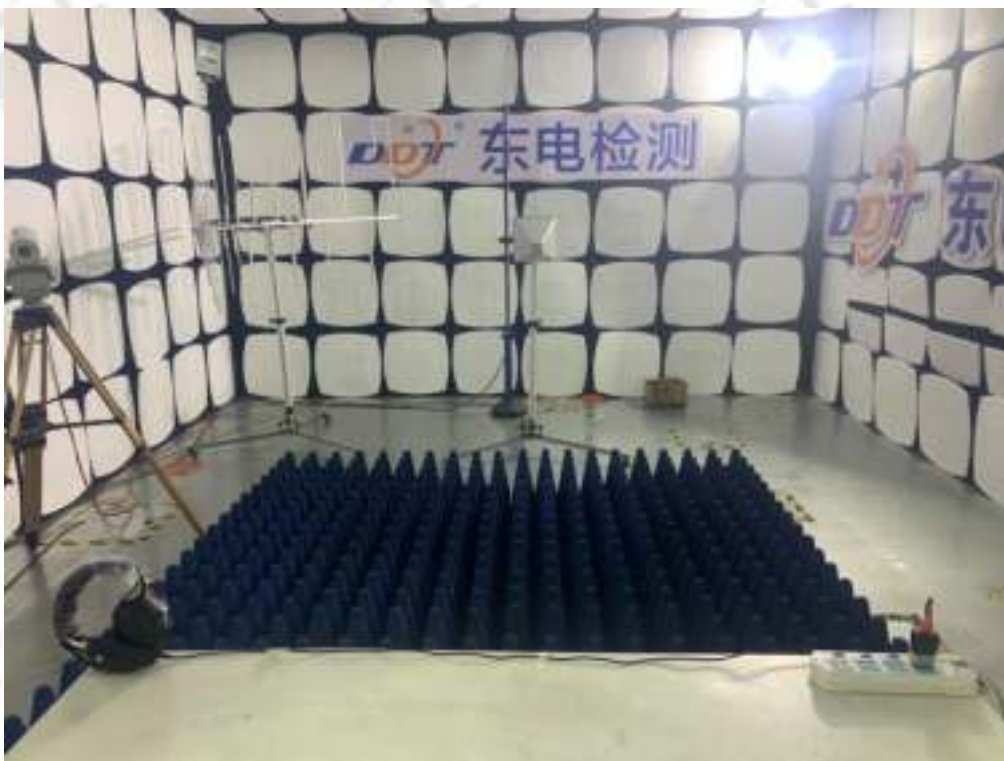
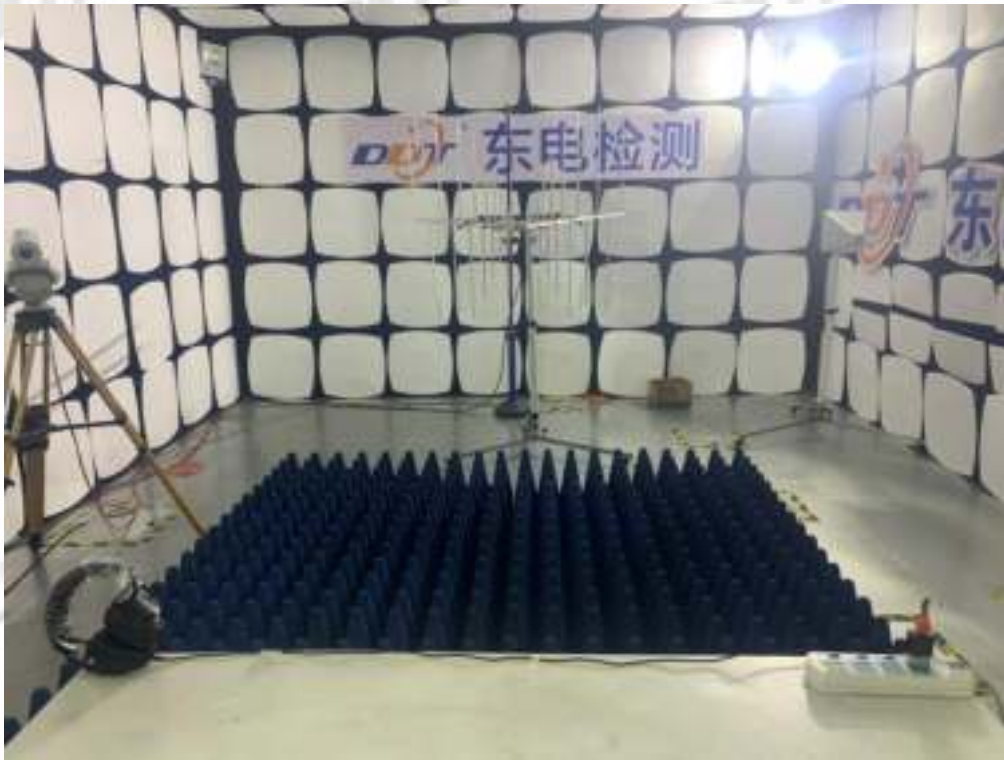

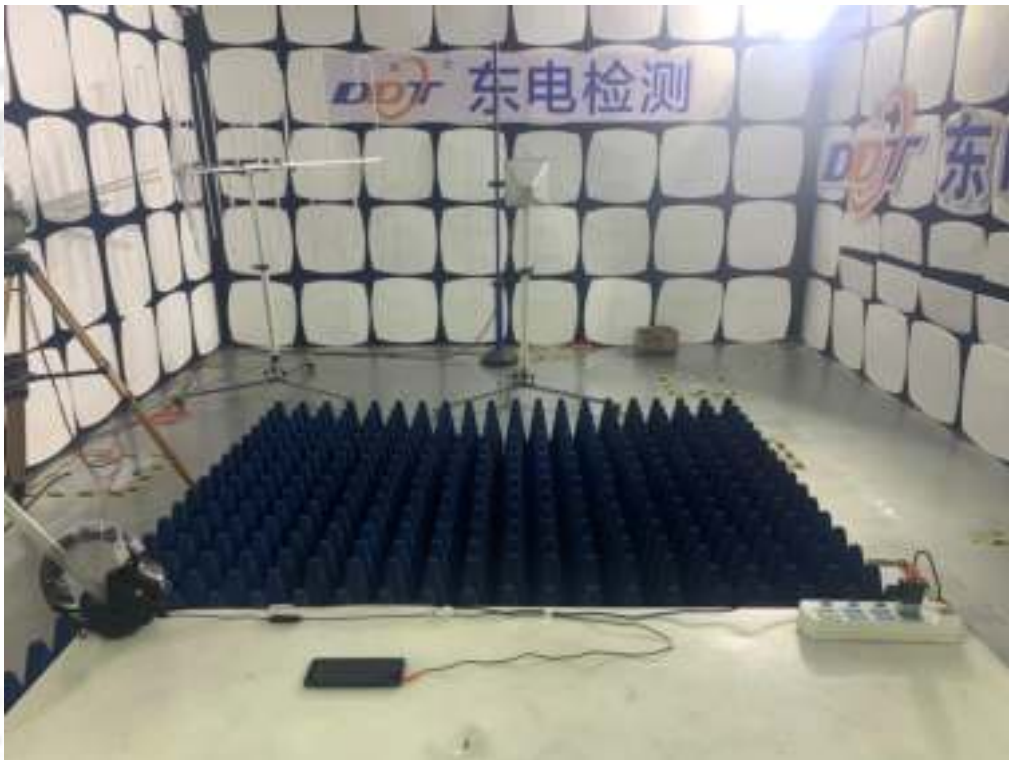
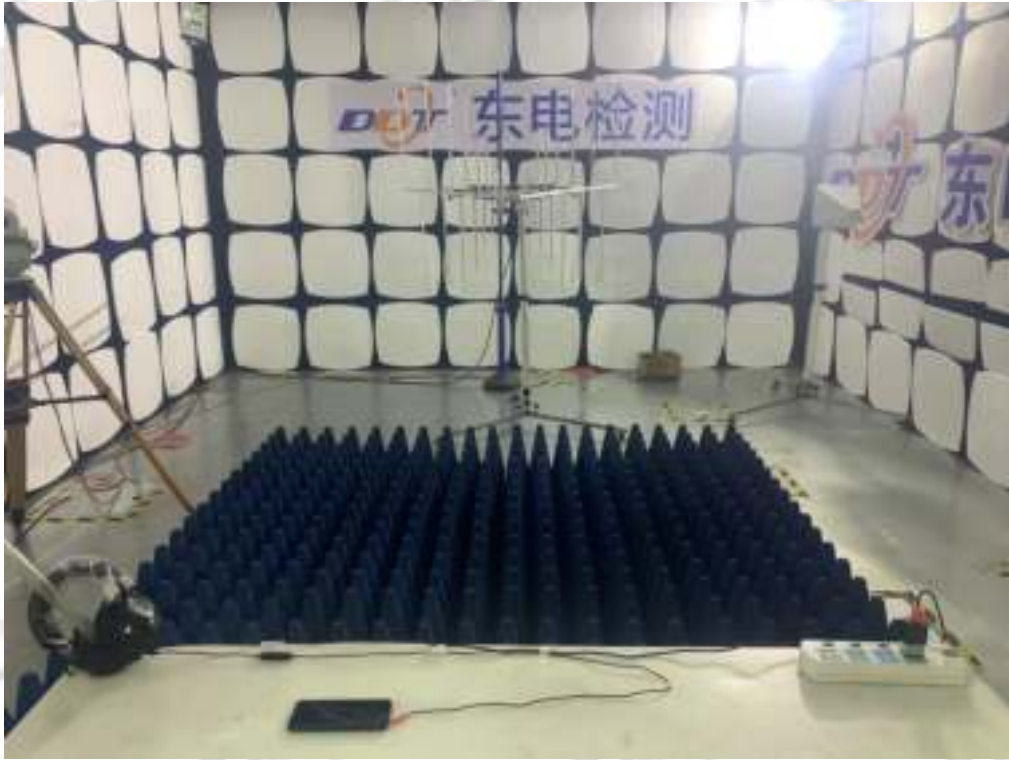

8. Electrical Fast Transients (EFT) Test Report

8.1. Test equipment

Equipment	Manufacturer	Model No.	Serial No.	Last Cal.	Cal. Interval
EFT Generator	EMC PARTNER	TRA3000F	TRA3000F-1502	Jun. 30, 2021	1 Year
Coupling Clamp EFT	EMC PARTNER	CN-EFT1000	103648	Jun. 30, 2021	1 Year

8.2. Block diagram of test setup

For power port (Note: if the DC network power cable may be lengths greater than 3 m, the requirement is applicable).

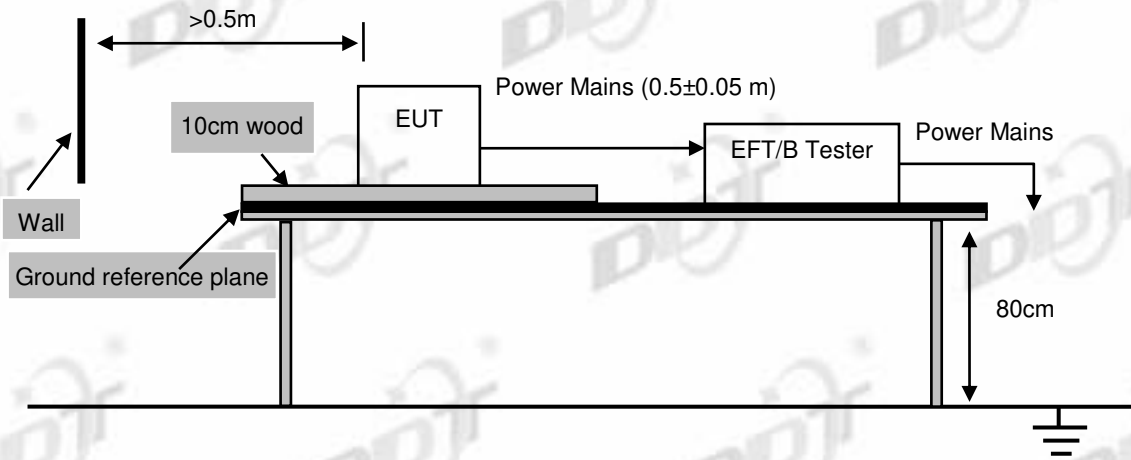

For analogue/digital data ports, if the cables may be longer than 3 m.

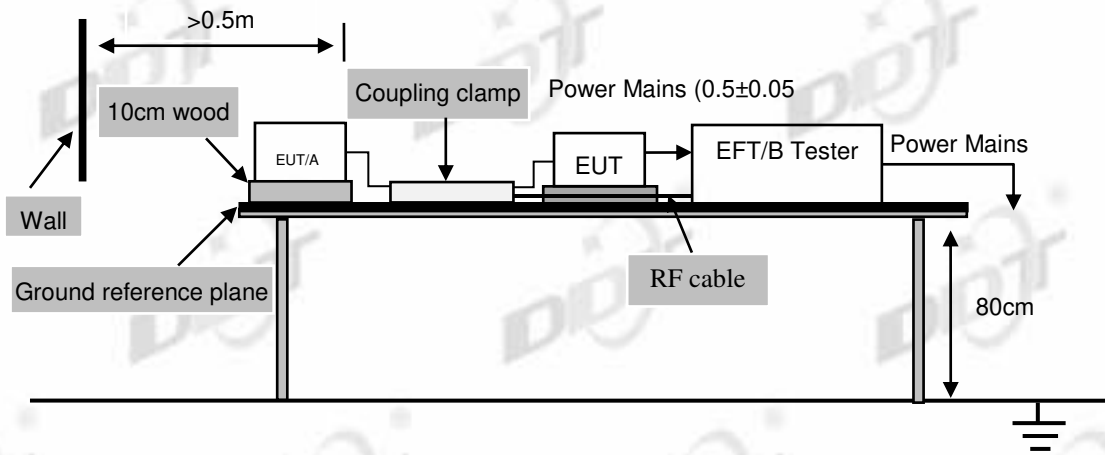

8.3. Test levels and performance criterion

Test Level			Performance Criteria
Test voltage	±1 kV for AC mains port	±0.5 kV for dc input or signal port	B
Repetition Frequency	5 kHz	5 kHz	
Burst Duration	15ms	15ms	
Burst Period	300ms	300ms	
Inject Time(s)	120s	120s	
Inject Method	Direct for AC mains port	Capacitive coupling clamp or CDN	
Inject Line	AC mains	Analogue/digital data ports, and DC network power ports	

Note: This test shall be additionally performed on analogue/digital data ports, and DC network power ports, of radio equipment and associated ancillary equipment, if the cables may be longer than 3 m.

Performance criteria B description: During the test, degradation of performance is allowed. However, no change of operating state or stored data is allowed to persist after the test. After the test, the EUT shall continue to operate as intended without operator intervention. No degradation of performance or loss of function is allowed, after the application of the phenomena below a performance level specified by the manufacturer, when the EUT is used as intended.

8.4. Assistant equipment used for test

Assistant equipment	Manufacturer	Model number	Description	other
Adapter	SAMSUNG	EP-TA200	N/A	Input: 100-240~, 50/60Hz, 0.5A; Output: 9V/1.67A or 5V/2A
Phone	SAMSUNG	SM-G9500	R28M63VA52Z	N/A

8.5. Test procedure

The EUT and its simulators were placed on the ground reference plane and were insulated from it by a wood support 0.1m ± 0.01m thick. The ground reference plane was 1m*1m metallic sheet with 0.65mm minimum thickness. This reference ground plane was project beyond the EUT by at least 0.1m on all sides and the minimum distance between EUT and all other conductive structure, except the ground plane was more than 0.5m. All cables to the EUT was placed on the wood support, cables not subject to EFT/B was routed as far as possible from the cable under test to minimize the coupling between the cables.

For DC input and AC power ports:

The EUT was connected to the power mains by using a coupling device that couples the EFT interference signal to AC or DC power lines. Both positive transients and negative transients of test voltage were applied during compliance test and the duration of the test can't less than 2mins.

For analogue/digital data ports:

The capacitive coupling clamp was connected to the power by using a coupling device that couples the EFT interference signal to capacitive coupling clamp. Both positive transients and negative transients of test voltage were applied during compliance test and the duration of the

test can't less than 2mins.

8.6. Test result

Test Site: DDT 7# Shield Room						
Ambient Condition: 22.8 °C, 49.6 %RH, 101.4 kPa						
Test Power supply: <input checked="" type="checkbox"/> AC 230V/50Hz, <input type="checkbox"/> Battery <input type="checkbox"/> DC:						
According Standard: <input checked="" type="checkbox"/> EN 61000-4-4:2012; <input checked="" type="checkbox"/> EN 55035, <input type="checkbox"/> other:						
Port: <input checked="" type="checkbox"/> AC Mains <input type="checkbox"/> DC Supply <input type="checkbox"/> Signal : Burst Period: <input checked="" type="checkbox"/> 300 ms <input type="checkbox"/> Other:						
Coupling: <input checked="" type="checkbox"/> Direct <input type="checkbox"/> Capacitive Clamp			Test Time: <input checked="" type="checkbox"/> 120 s <input type="checkbox"/> Other:			
Repetition Frequency: <input checked="" type="checkbox"/> 5 kHz <input type="checkbox"/> 100 kHz			Burst Duration: <input checked="" type="checkbox"/> 15 ms <input type="checkbox"/> Other:			
Operation Mode	Line/port	Test Voltage	Performance			Result (Pass/Fail)
			Required	Observation (+)	Observation (-)	
Charging mode	L	1 kV	B	A	A	Pass
	N	1 kV	B	A	A	Pass
	L-N	1 kV	B	A	A	Pass
	Signal port	0.5 kV	B	/	/	/
Charging + Aux in mode	L	1 kV	B	A	A	Pass
	N	1 kV	B	A	A	Pass
	L-N	1 kV	B	A	A	Pass
	Signal port	0.5 kV	B	/	/	/
Observation Description: A: Operation as intend, no loss of function during test and after test.						
Test Engineer: Elosky Liu				Test Date: Oct. 25, 2021		

8.7. Test photo





9. Surges test report

9.1. Test equipment

Equipment	Manufacturer	Model No.	Serial No.	Last Cal.	Cal. Interval
Surge Generator	EMC PARTNER	TRANSIENT2000	MIG0603IN2 S-T-1504	Jun. 01, 2021	1 Year
Coupling/Decoupling Network for communication port	EMC PARTNER	CDN-UTP8 ED3	1557	Sep. 02, 2021	1 Year
Coupling/Decoupling Network for signal port	EMC PARTNER	CDN-KIT1000	CDN-KIT1000-1510	Jun. 01, 2021	1 Year

9.2. Block diagram of test setup

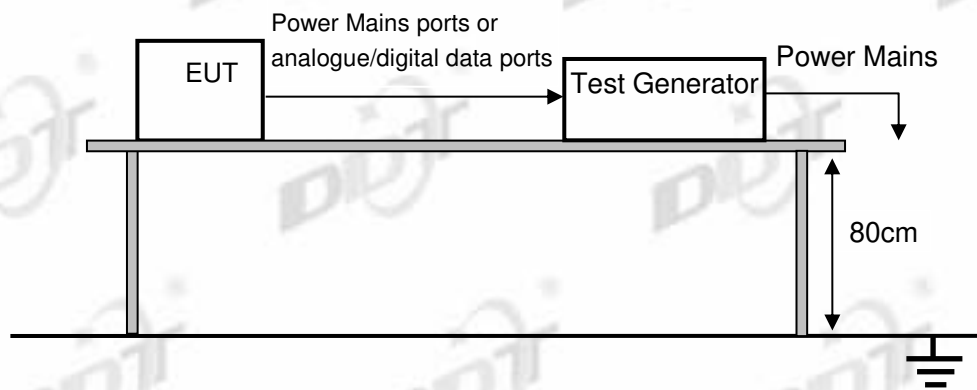

9.3. Test levels and performance criterion

Test level for AC mains ports		Performance Criterion
Line to Line	1 kV 1.2/50(8/20) μ s	B
Line to Ground	2 kV 1.2/50(8/20) μ s	B
Analogue/digital data port, Port type: unshielded symmetrical		Performance Criterion
Line to Ground	1 kV and 4 kV 10/700(5/320) μ s (used with the primary protection)	C
Line to Ground	1 kV 10/700(5/320) μ s (used without the primary protection)	C
Note: Applicable only to ports which, according to the manufacturer's specification, the cable lengths greater than 3m.		
Analogue/digital data port, Port type: coaxial or shielded		Performance Criterion
Shield to ground	0.5 kV 1.2/50(8/20) μ s	B
Note: Applicable only to ports which, according to the manufacturer's specification, the cable lengths greater than 3m.		
DC network power port		Performance Criterion
Line to reference ground	0.5 kV 1.2/50(8/20) μ s	B

Note: Applicable only to ports which, according to the manufacturer's specification, 1. The cable lengths greater than 3m; 2. May connect directly to outdoor cables.

Performance criteria B description: During the test, degradation of performance is allowed. However, no change of operating state or stored data is allowed to persist after the test. After the test, the EUT shall continue to operate as intended without operator intervention. No degradation of performance or loss of function is allowed, after the application of the phenomena below a performance level specified by the manufacturer, when the EUT is used as intended.

9.4. Assistant equipment used for test

Assistant equipment	Manufacturer	Model number	Description	other
Adapter	SAMSUNG	EP-TA200	N/A	Input: 100-240~, 50/60Hz, 0.5A; Output: 9V/1.67A or 5V/2A
Phone	SAMSUNG	SM-G9500	R28M63VA52Z	N/A

9.5. Test procedure

For line-to-neutral coupling mode, provide a 0.5 kV/1 kV 1.2/50 us voltage surge (at open-circuit condition) and 8/20 us current surge to EUT selected points.

For line-to-ground coupling mode, provide a 0.5 kV/1 kV/2 kV 1.2/50 us voltage surge (at open-circuit condition) and 8/20 us current surge to EUT selected points.

The number of pulses applied shall be as follows:

- Five positive pulses line-to-neutral at 90° phase
- Five negative pulses line-to-neutral at 270° phase

The following additional pulses are required only if the EUT has an earth connection or if the EUT is earthed via any AE.

- Five positive pulses line-to-earth at 90° phase
- Five negative pulses line-to-earth at 270° phase
- Five negative pulses neutral-to-earth at 90° phase
- Five positive pulses neutral-to-earth at 270° phase

Maximum 1/min repetition rate are applied during test.

Different phase angles are done individually.

For telecommunication surge test, each line of internet port to ground coupling mode, provide a 1.0 kV 10/700 us voltage surge (at open-circuit condition) and 5/320us current surge to EUT selected points.

At least 5 positive and 5 negative (polarity) tests with a maximum 1/min repetition rate are applied during test.

Record the EUT operating situation during compliance test and decide the EUT immunity criterion for above each test.

9.6. Test result

Test Site: DDT Surges Room											
Ambient Condition: <u>22.8</u> °C, <u>49.6</u> %RH, <u>101.4</u> kPa											
Test Power supply: <input checked="" type="checkbox"/> AC 230V/50Hz, <input type="checkbox"/> Battery <input type="checkbox"/> DC:											
According Standard: <input checked="" type="checkbox"/> EN 61000-4-5:2014/A1:2017, <input checked="" type="checkbox"/> EN 55035, <input type="checkbox"/> other:											
Line : <input checked="" type="checkbox"/> AC Mains <input type="checkbox"/> DC Supply <input type="checkbox"/> Signal											
Wave Type: <input checked="" type="checkbox"/> 1.2/50us-8/20us <input type="checkbox"/> 10/700 us-5/320us											
Pluse times: <input checked="" type="checkbox"/> Five positive pluses at 90°phase, five negative pluses at 270°phase. <input type="checkbox"/> Five positive pluses and five negative pluses at 0°, 90°, 180°, 270°.											
Pulse Interval: 60 s											
Operation Mode	Line/Port	0.5 kV			1 kV			2 kV			Result (Pass/Fail)
		Performance			Performance			Performance			
		Required	+	-	Required	+	-	Required	+	-	
Charging mode	L-N	B	A	A	B	A	A	/	/	/	Pass
	L-PE	/	/	/	/	/	/	/	/	/	/
	N-PE	/	/	/	/	/	/	/	/	/	/
	Signal port	/	/	/	/	/	/	/	/	/	/
Charging + Aux in mdoe	L-N	B	A	A	B	A	A	/	/	/	Pass
	L-PE	/	/	/	/	/	/	/	/	/	/
	N-PE	/	/	/	/	/	/	/	/	/	/
	Signal port	/	/	/	/	/	/	/	/	/	/
Observation Description: A: Operation as intend, no loss of function during test and after test.											
Test engineer: Elosky Liu						Test date: Oct. 25, 2021					

9.7. Test photo



10. Continuous Conducted Disturbances

10.1. Test equipment

Equipment	Manufacturer	Model No.	Serial No.	Last Cal.	Cal. Interval
Conducted Immunity Tester	FRANKONIA	CIT-10	126B1207	Jun. 01, 2021	1 Year
CDN	FRANKONIA	CDNT8	A6100017/2012	Sep. 02, 2021	1 Year
CDN	SCHWARZBECK	CDN M2+M3PE 16A	00058	Sep. 02, 2021	1 Year
CDN	SHANGHAI LIONCEL	CDN M3-32	191001	Sep. 02, 2021	1 Year
CDN	SHANGHAI LIONCEL	CDN M3-L-100	0200801J	Sep. 02, 2021	1 Year
EM Clamp	FRANKONIA	EMCL	132A1143/2012	Sep. 02, 2021	1 Year
Attenuation	BIRD	DAM75W (6dB)	1143	Sep. 02, 2021	1 Year
Test Software	SKET	EMC-S	V1.2.0.80	N/A	N/A
Accessory Equipment used for test					
Audio Analyzer	R&S	UPL16	100167	Jun. 10, 2021	1 Year
Audio Analyzer	R&S	UPV	101570	Sep. 02, 2021	1 Year
MXG Vector Generator	Agilent	N5182A	MY47420276	Sep. 02, 2021	1 Year
EXG Vector Signal Generator	Agilent	N5172B	MY53050018	Sep. 02, 2021	1 Year
Digital Video test software	Keysight	N7623B	Version 8.0.0.1	N/A	N/A
Microphone	Supwerlux	ECM888B	E888B5A0298	N/A	N/A
Artificial Ear	AIHUA	Type0213	2018022701	N/A	N/A
Artificial Ear	AIHUA	Type0212	2017102603	N/A	N/A

Note: N/A means not applicable.

10.2. Block diagram of test setup

For power port (Note: if the DC network power cable may be lengths greater than 3 m, the requirement is applicable).

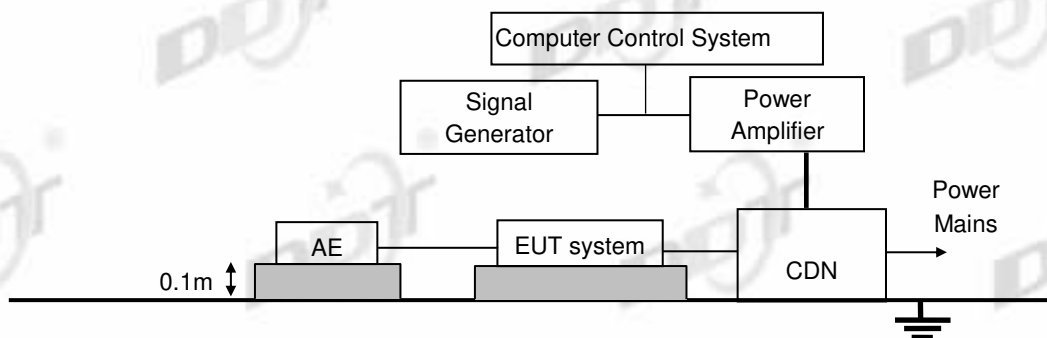

For analogue/digital data ports, if the cables may be longer than 3 m.

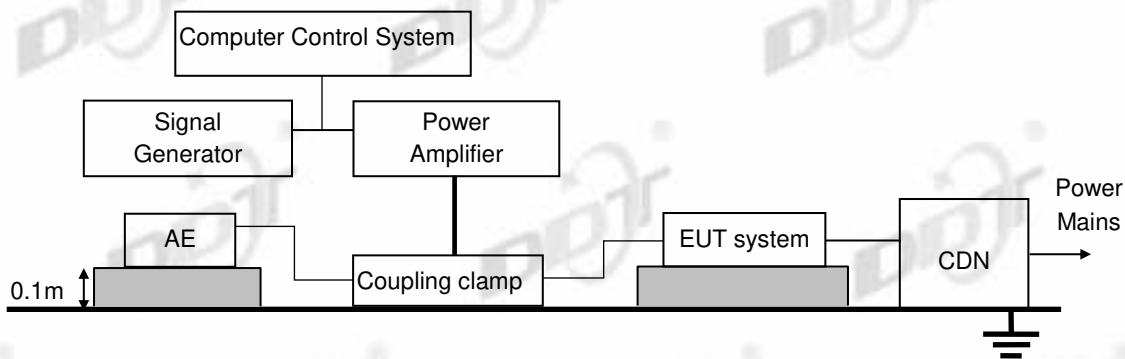

For audio output function (electrical measurement, direct connection to EUT)

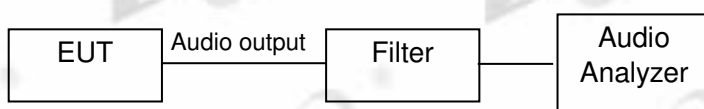

For audio output function (acoustic measurement)

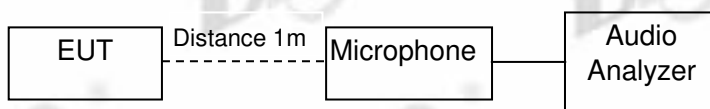

For audio output function (on-ear acoustic measurement)

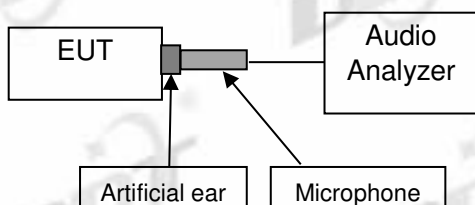

10.3. Test levels and performance criterion

Test Level		Performance Criteria
Frequency and Field Strength	0.15 MHz to 10 MHz, 3V rms voltage level of the unmodulated signal	A
	10 MHz to 30 MHz, 3V to 1V rms voltage level of the unmodulated signal	
	30 MHz to 80 MHz, 1V rms voltage level of the unmodulated signal	
Modulation	AM modulated to a depth of 80% by a sine wave of <input checked="" type="checkbox"/> 1 kHz, <input type="checkbox"/> 400 Hz (note 1)	
Step Size	1% increments	
Dwell time	≤5 Sec.	

Note 1: The 1 kHz modulation may be replaced by a different audio modulation frequency more appropriate for a given EUT if, for example, 1 kHz is not within the operating audio range of the EUT.

Note 2: This test shall be additionally performed on analogue/digital data ports, DC network power ports of equipment, if the cables may be longer than 3 m.

Performance criteria A description for devices with the audio output function: The measured acoustic interference ratio and/or the measured electrical interference ratio during the test shall be -20 dB or better.

The acoustic measurement method was selected according to clause G6.4.1 of EN 55035.

The electrical measurement method was selected according to clause G6.4.2 of EN 55035.

Performance criteria A for devices with the telephony function.

Frequency range MHz	Acoustic or electrical interference ratio	Equivalent direct measurement		
		dB(SPL)	Digital dBm0	Analogue dBm0
0.15 to 30	-20 dB	55	-50	-50
30 to 80	-10 dB	65	-40	-40

Note: At the step in the frequency range, the lower limit shall be applied.

The interference ratio (electrical or acoustic) shall meet the limits in column 2; or,

The acoustic level of the demodulated audio shall be less than the limits in column 3; or

The digitally coded level of demodulated audio shall be less than limits in column 4; or,

The analogue level of the demodulated audio shall be less than the limits in column 5.

Performance criteria A description for other devices: During and after the test the EUT shall continue to operate as intended without operator intervention. No degradation of performance or loss of function is allowed below a minimum performance level specified by the manufacturer when the EUT is used as intended.

10.4. Assistant equipment used for test

Assistant equipment	Manufacturer	Model number	Description	other
Adapter	SAMSUNG	EP-TA200	N/A	Input: 100-240~, 50/60Hz, 0.5A; Output: 9V/1.67A or 5V/2A
Phone	SAMSUNG	SM-G9500	R28M63VA52Z	N/A

10.5. Test procedure

The EUT are placed on an insulating support 0.1m high above a ground reference plane. CDN (coupling and decoupling device) is placed on the ground plane about 0.3m from EUT. Cables between CDN and EUT are as short as possible, and their height above the ground reference plane shall be between 30 and 50 mm (where possible).

The disturbance signal described below is injected to EUT through CDN.

The EUT operates within its operational mode(s) under intended climatic conditions after power on. The frequency range is swept from 0.15 MHz to 80 MHz, the interference signal level according to standard, and with the disturbance signal 80% amplitude modulated with a 1 kHz/ 400 Hz sine wave.

The rate of sweep shall not exceed 1.5×10^{-3} decades/s. Where the frequency is swept incrementally; the step size shall not exceed 1% of the start and thereafter 1% of the preceding frequency value.

Recording the EUT operating situation during compliance testing and decide the EUT immunity criterion.

10.6. Test result

Test Site: DDT Continuous Conducted Disturbances Room						
Ambient Condition: <u>24.5</u> °C, <u>53.6</u> %RH, <u>101.4</u> kPa						
Test Power supply: <input checked="" type="checkbox"/> AC 230V/50Hz, <input type="checkbox"/> Battery <input type="checkbox"/> DC:						
According Standard: <input checked="" type="checkbox"/> EN 61000-4-6:2014/AC:2015, <input checked="" type="checkbox"/> EN 55035, <input type="checkbox"/> other:						
Modulation Signal: <input checked="" type="checkbox"/> 1 kHz <input type="checkbox"/> 400 Hz 80% AM <input type="checkbox"/> Other:						
Steps: <input checked="" type="checkbox"/> 1% <input type="checkbox"/> other: Dwell time: <input checked="" type="checkbox"/> 1s <input type="checkbox"/> other:						
Operation mode	Frequency Range	Injected Position	Strength(e.m.f) (unmodulated)	Required	Observation	Result (Pass/Fail)
Charging mode	0.15 MHz-10 MHz	AC port	3V	A	A	Pass
	10 MHz-30 MHz		3V-1V	A	A	Pass
	30 MHz-80 MHz		1V	A	A	Pass
Charging + Aux in mode	0.15 MHz-10 MHz	AC port	3V	A	A	Pass
	10 MHz-30 MHz		3V-1V	A	A	Pass
	30 MHz-80 MHz		1V	A	A	Pass
Charging + Aux in mode: Acoustic interference ratio= <u>-36.599</u> dB≤-20dB.						
Note 1: this row only for the device with audio output function.						
Note 2: this device without the telephony function.						
Observation Description:						
A: Operation as intend, no loss of function during test and after test.						
Test Engineer: Aric Wang				Test Date: Oct. 25, 2021		

The worst data results are summarized as follows:
Charging + Aux in mode

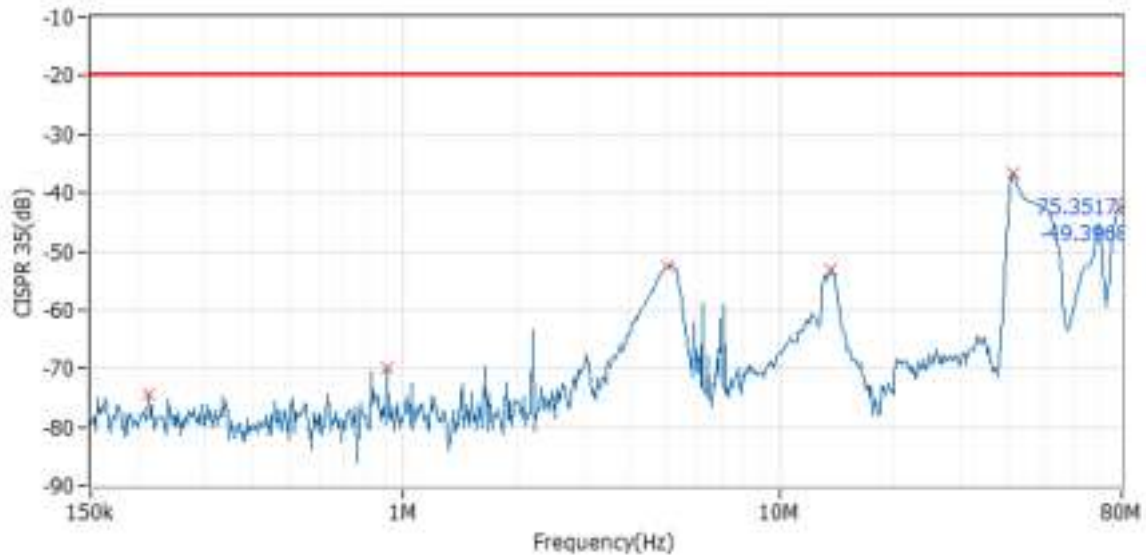

Frequency	UpperLimit	Lowerlimit	Value	Title
79.195476 MHz	-20dB	-	-42.257dB	CISPR 35
41.066668 MHz	-20dB	-	-36.599dB	CISPR 35
13.608676 MHz	-20dB	-	-53.013dB	CISPR 35
5.031249 MHz	-20dB	-	-52.435dB	CISPR 35
908.614 kHz	-20dB	-	-69.968dB	CISPR 35
212.511 kHz	-20dB	-	-74.452dB	CISPR 35

10.7. Test photo





11. Power-Frequency Magnetic Fields

11.1. Test equipment

Equipment	Manufacturer	Model No.	Serial No.	Last Cal.	Cal. Interval
EFT Generator	EMC PARTNER	TRA3000F	TRA3000F-1502	Jun. 30, 2021	1 Year
Magnetic Field Tester	EMC PARTNER	MF1000-1	207	Dec. 09, 2020	1 Year

11.2. Block diagram of test setup

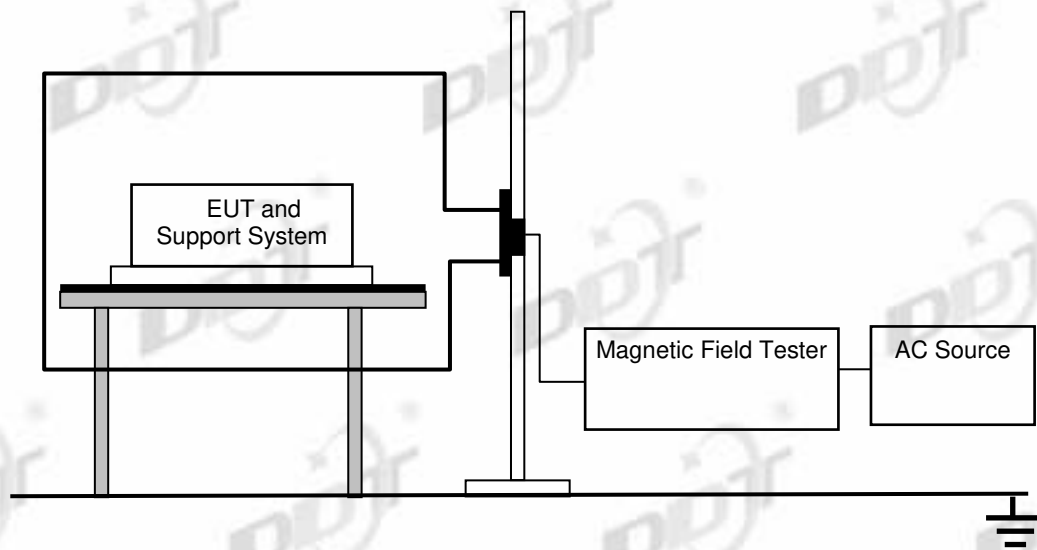

11.3. Test levels and performance criterion

Level	Magnetic Field Strength (A/m)	Performance Criterion
1	1	A

Performance criteria A description: During and after the test the EUT shall continue to operate as intended without operator intervention. No degradation of performance or loss of function is allowed below a minimum performance level specified by the manufacturer when the EUT is used as intended.

11.4. Assistant equipment used for test

Assistant equipment	Manufacturer	Model number	Description	other
Adapter	SAMSUNG	EP-TA200	N/A	Input: 100-240~, 50/60Hz, 0.5A; Output: 9V/1.67A or 5V/2A
Phone	SAMSUNG	SM-G9500	R28M63VA5 2Z	N/A

11.5. Test procedure

The EUT shall be subjected to the test magnetic field by using the induction coil of standard dimensions (1m*1m). Then induction coil shall then be rotated by 90° in order to expose the EUT to the test field with different orientations.

11.6. Test result

Test Site: DDT 7# Shield Room						
Ambient Condition: <u>22.8</u> °C, <u>49.6</u> %RH, <u>101.4</u> kPa						
Test Power supply : <input checked="" type="checkbox"/> AC 230V/50Hz, <input checked="" type="checkbox"/> Battery <input type="checkbox"/> DC :						
According Standard : <input checked="" type="checkbox"/> EN 61000-4-8:2010, <input checked="" type="checkbox"/> EN55035, <input type="checkbox"/> other:						
Operation Mode	Test Level	Testing Duration	Coil Orientation	Required	Observation	Result
						(Pass/Fail)
Charging mode	1A/m, 50 Hz	5 min / coil	X	A	A	Pass
			Y	A	A	Pass
			Z	A	A	Pass
Charging + Aux in mode	1A/m, 50 Hz	5 min / coil	X	A	A	Pass
			Y	A	A	Pass
			Z	A	A	Pass
Aux in mode	1A/m, 50 Hz	5 min / coil	X	A	A	Pass
			Y	A	A	Pass
			Z	A	A	Pass
Standby mode	1A/m, 50 Hz	5 min / coil	X	A	A	Pass
			Y	A	A	Pass
			Z	A	A	Pass
Observation Description: A: Operation as intend, no loss of function during test and after test.						
Test Engineer: Elosky Liu					Test Date: Oct. 25, 2021	

11.7. Test photo

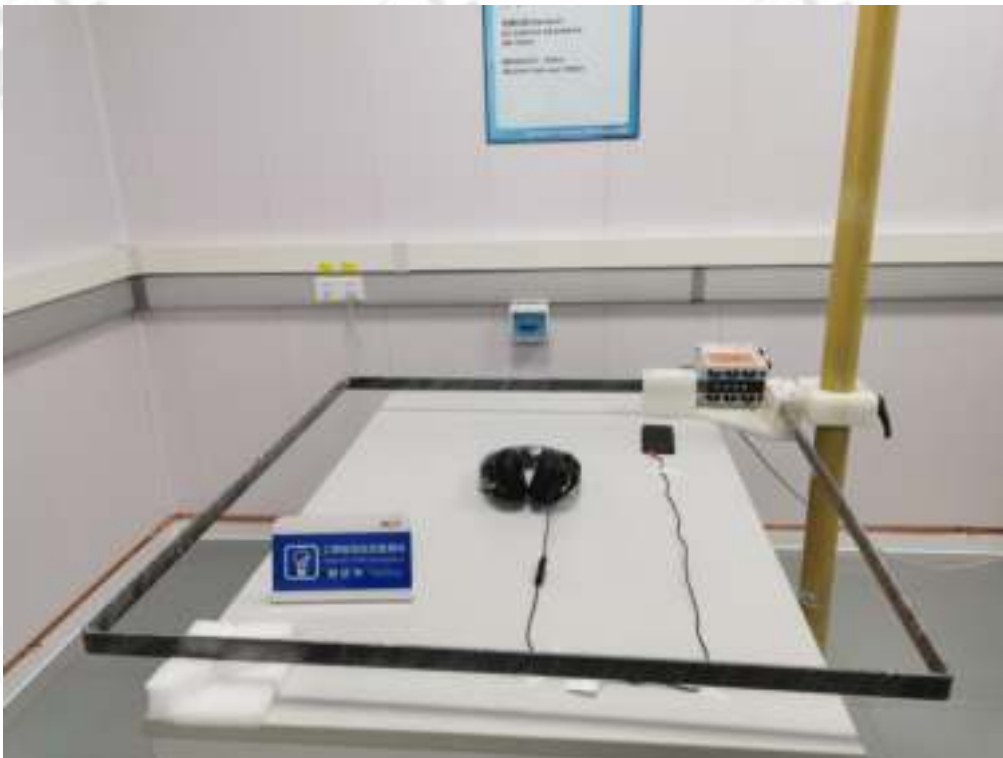
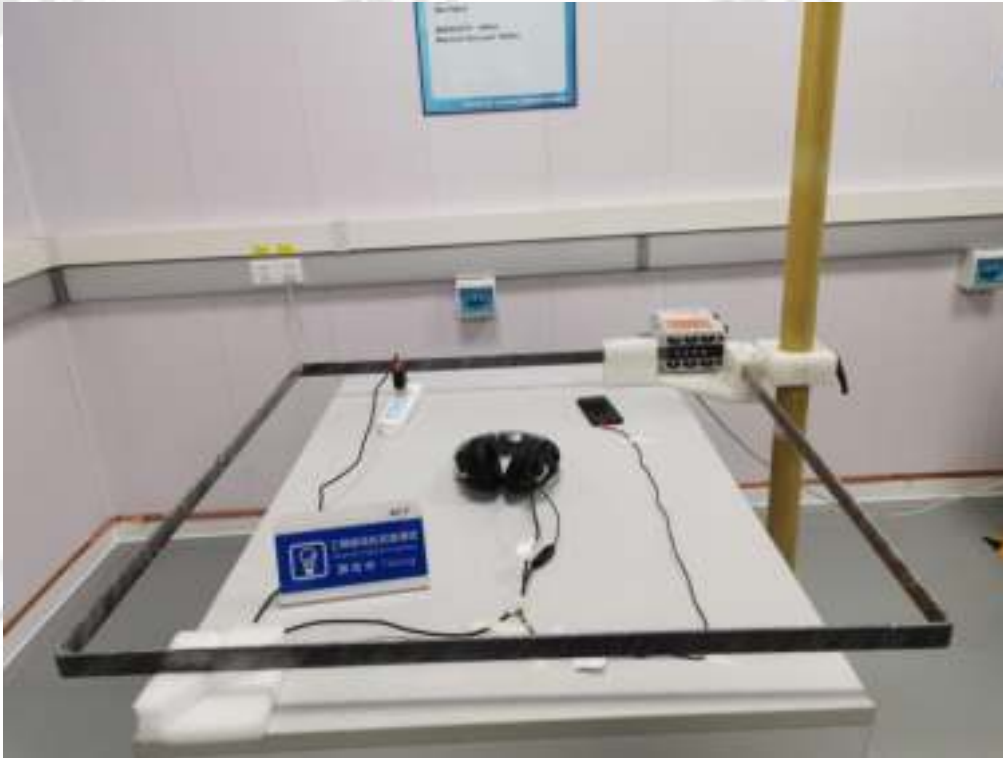

12. Voltage Dips and Interruptions

12.1. Test Equipment

Equipment	Manufacturer	Model No.	Serial No.	Last Cal.	Cal. Interval
EFT Generator	EMC PARTNER	TRA3000F	TRA3000F-1502	Jun. 30, 2021	1 Year
DIPS TESTER	EMC PARTNER	EXT-TRA3000D	EXT-TRA3000D-1510	Jun. 01, 2021	1 Year

12.2. Block diagram of test setup

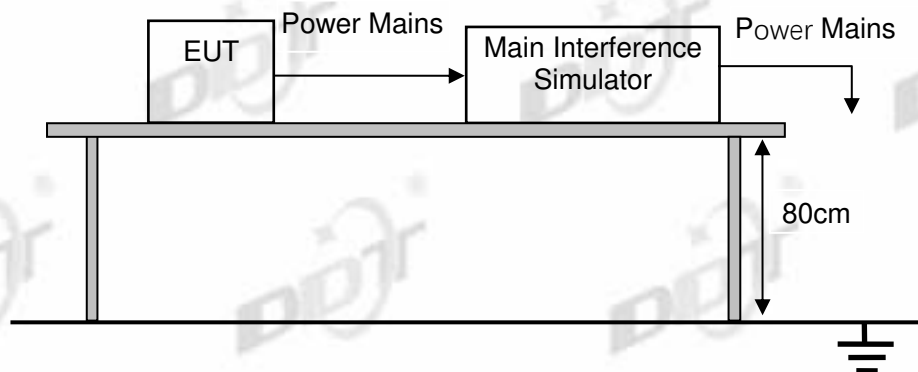

12.3. Test levels and performance criterion

Test Level %UT	Duration (in period)	Performance Criterion
<5	0.5	B
70	25 for 50 Hz/30 for 60 Hz	C
<5	250 for 50 Hz/300 for 60 Hz	C

Performance criteria B description: During the test, degradation of performance is allowed. However, no change of operating state or stored data is allowed to persist after the test. After the test, the EUT shall continue to operate as intended without operator intervention. No degradation of performance or loss of function is allowed, after the application of the phenomena below a performance level specified by the manufacturer, when the EUT is used as intended.

Performance criteria C description: During and after testing, a temporary loss of function is allowed, provided the function is self recoverable, or can be restored by the operation of the controls or cycling of the power to the EUT by the user in accordance with the manufacturer's instructions. Functions, and/or information stored in non-volatile memory, or protected by a battery backup, shall not be lost.

12.4. Assistant equipment used for test

Assistant equipment	Manufacturer	Model number	Description	other
Adapter	SAMSUNG	EP-TA200	N/A	Input: 100-240~, 50/60Hz, 0.5A; Output: 9V/1.67A or 5V/2A
Phone	SAMSUNG	SM-G9500	R28M63VA52Z	N/A

12.5. Test Procedure

The EUT and test generator were setup as shown. The interruptions are introduced at selected phase angles with specified duration. Record any degradation of performance.

Note: Changes to occur at 0 degree crossover point of the voltage waveform. If the EUT does not demonstrate compliance when tested with 0 degree switching, the test shall be repeated with the switching occurring at both 90 degrees and 270 degrees. If the EUT satisfies these alternative requirements, then it fulfils the requirements.

12.6. Test result

Test Site: DDT 7# Shield Room						
Ambient Condition: <u>22.8</u> °C, <u>49.6</u> %RH, <u>101.4</u> kPa						
Test Power supply: <input checked="" type="checkbox"/> AC 240V/50Hz						
According Standard: <input checked="" type="checkbox"/> EN 61000-4-11:2004/A1:2017, <input checked="" type="checkbox"/> EN 55035, <input type="checkbox"/> other:						
Operation Mode	Voltage Dips & Interruptions %Ur	Duration (in period)	Phase Angle	Required	Observation	Result (Pass/Fail)
Charging mode	0	0.5P	0° to 360°	B	A	Pass
	70	25P	0° to 360°	C	A	Pass
	0	250P	0° to 360°	C	B	Pass
Charging + Aux in mode	0	0.5P	0° to 360°	B	A	Pass
	70	25P	0° to 360°	C	A	Pass
	0	250P	0° to 360°	C	B	Pass
Observation Description:						
A: Operation as intend, no loss of function during test and after test;						
B: EUT will stop charging and can recover by itself after test.						
Test Engineer: Elosky Liu				Test Date: Oct. 25, 2021		

Test Site: DDT 7# Shield Room						
Ambient Condition: <u>22.8</u> °C, <u>49.6</u> %RH, <u>101.4</u> kPa						
Test Power supply: <input checked="" type="checkbox"/> AC 100V/60Hz						
According Standard: <input checked="" type="checkbox"/> EN 61000-4-11:2004/A1:2017, <input checked="" type="checkbox"/> EN 55035, <input type="checkbox"/> other:						
Operation Mode	Voltage Dips & Interruptions %Ur	Duration (in period)	Phase Angle	Required	Observation	Result (Pass/Fail)
Charging mode	0	0.5P	0° to 360°	B	A	Pass
	70	30P	0° to 360°	C	A	Pass
	0	300P	0° to 360°	C	B	Pass
Charging + Aux in mode	0	0.5P	0° to 360°	B	A	Pass
	70	30P	0° to 360°	C	A	Pass
	0	300P	0° to 360°	C	B	Pass
Observation Description:						
A: Operation as intend, no loss of function during test and after test;						
B: EUT will stop charging and can recover by itself after test.						
Test Engineer: Elosky Liu				Test Date: Oct. 25, 2021		

12.7. Test photo



13. Photos of the EUT















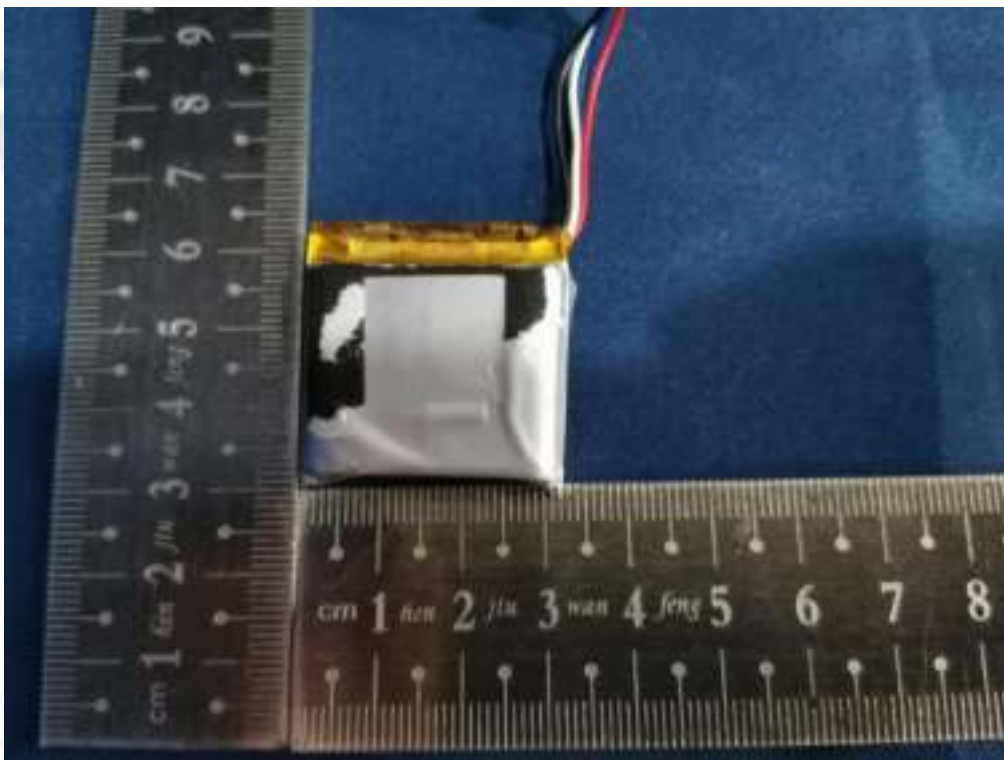
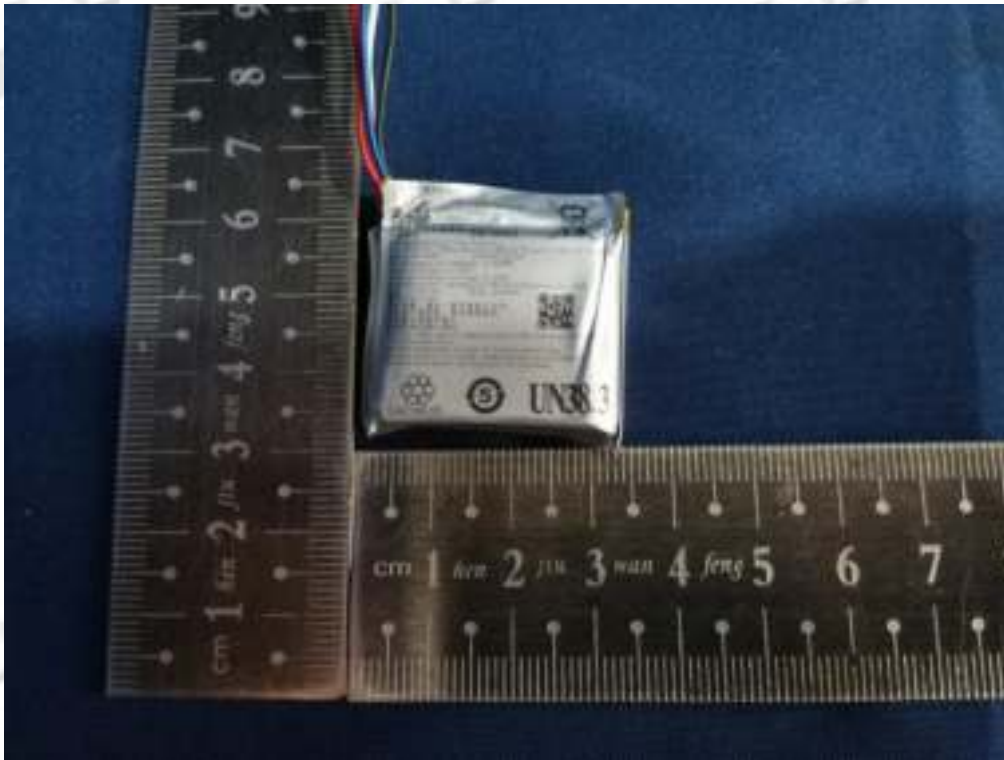



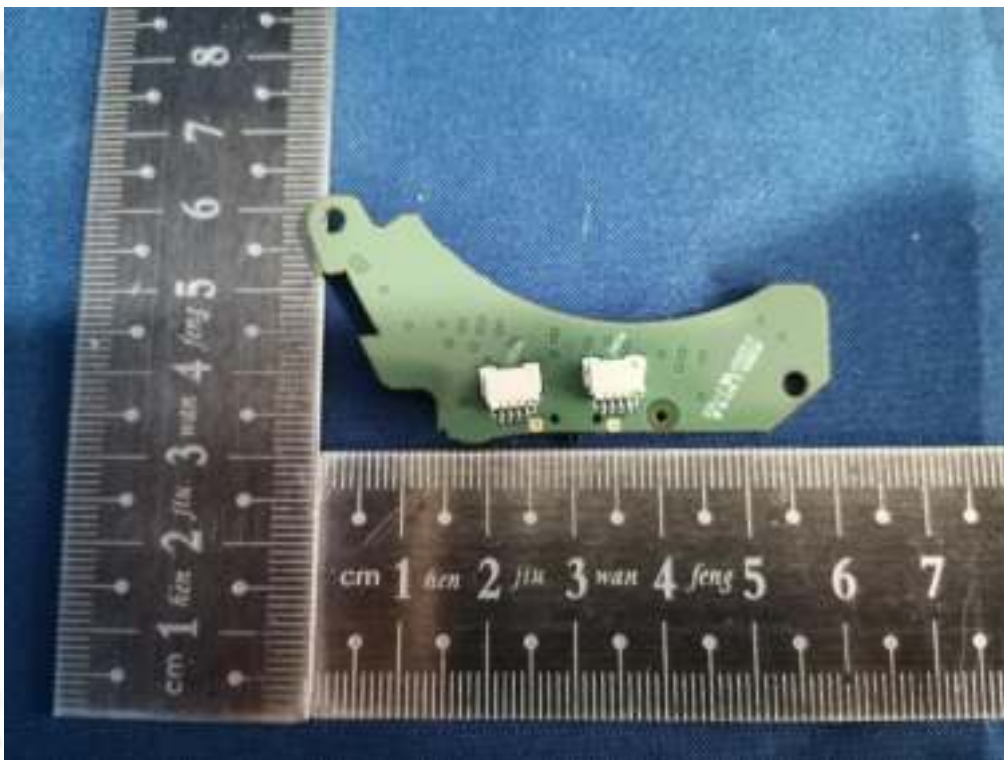
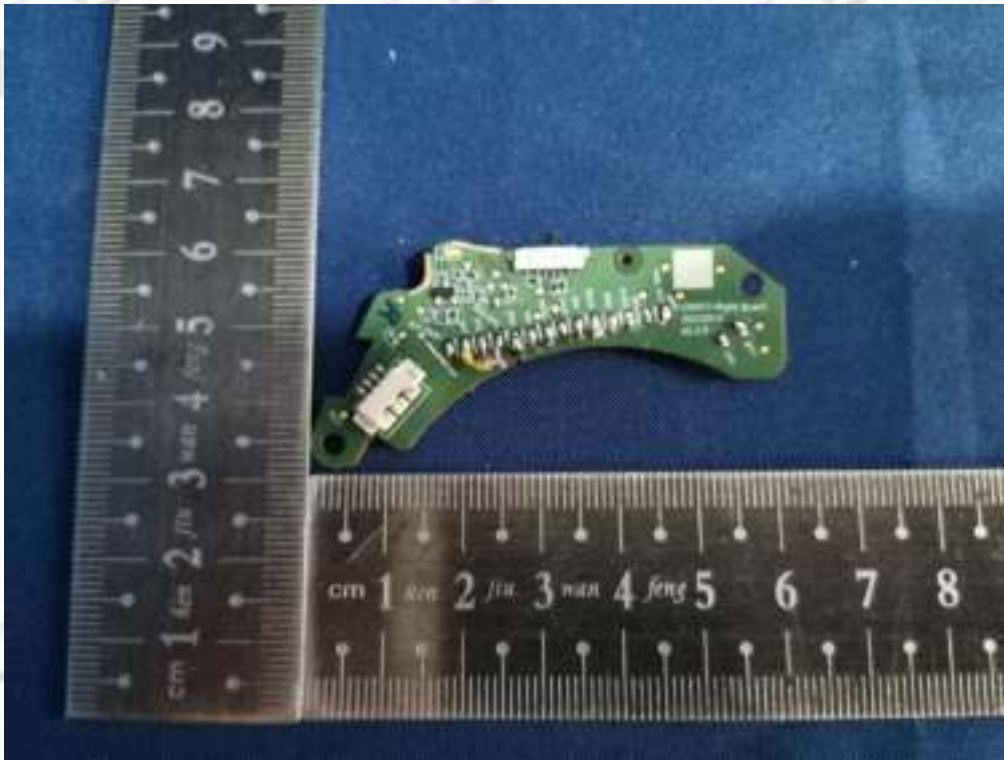



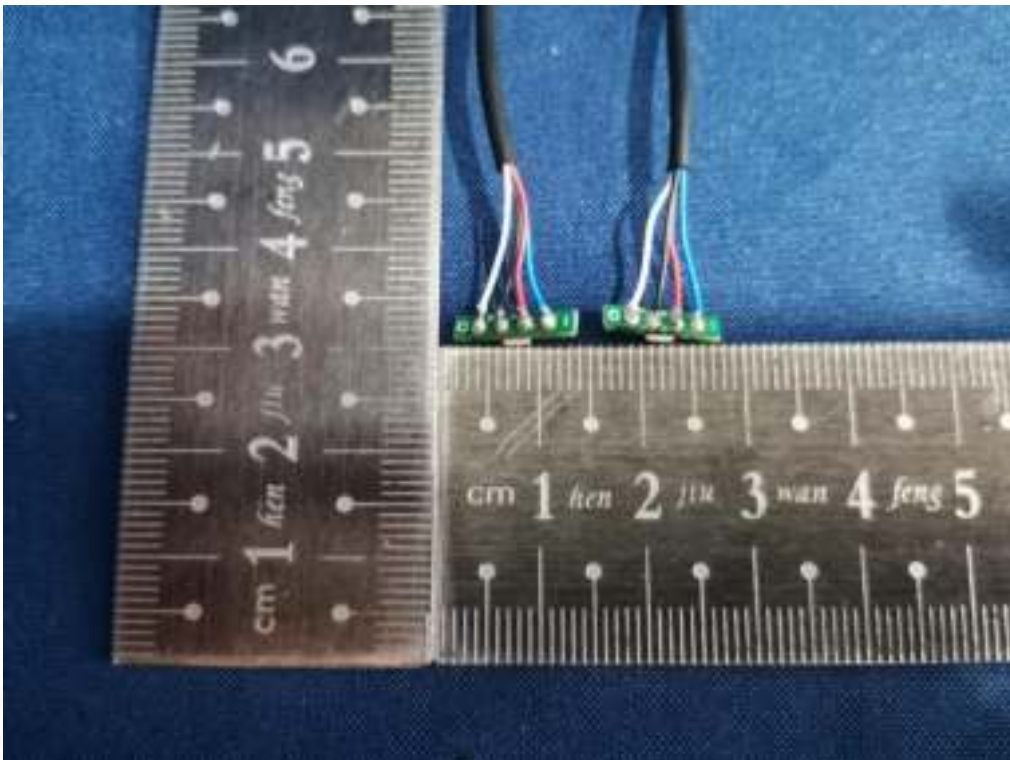
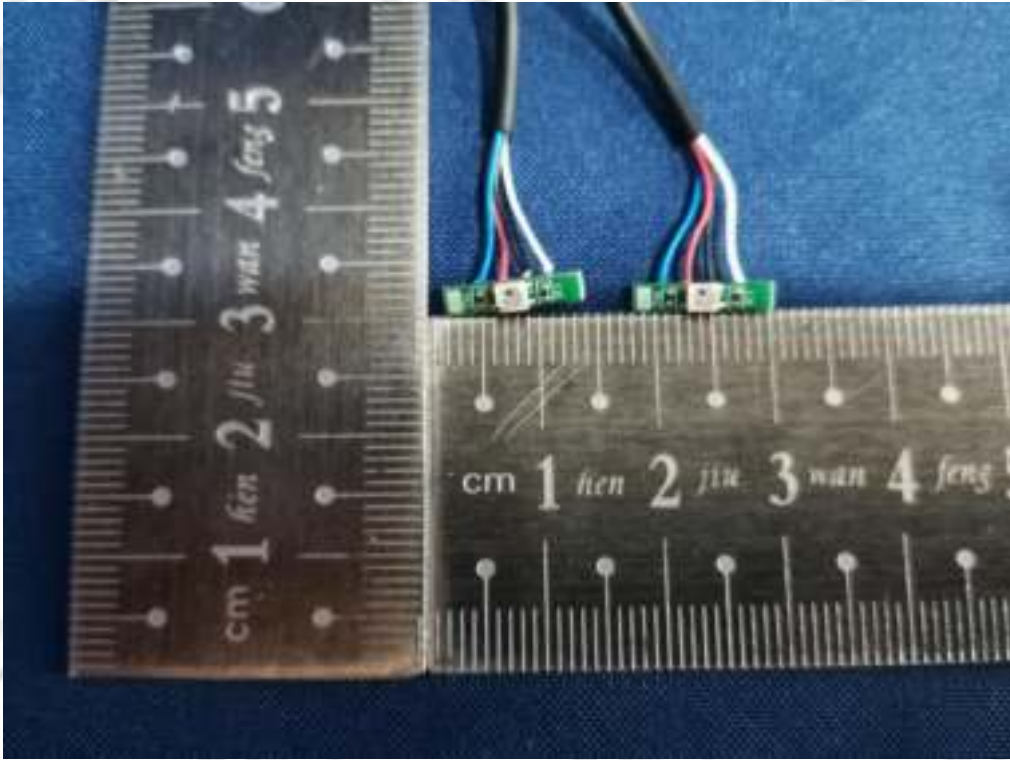

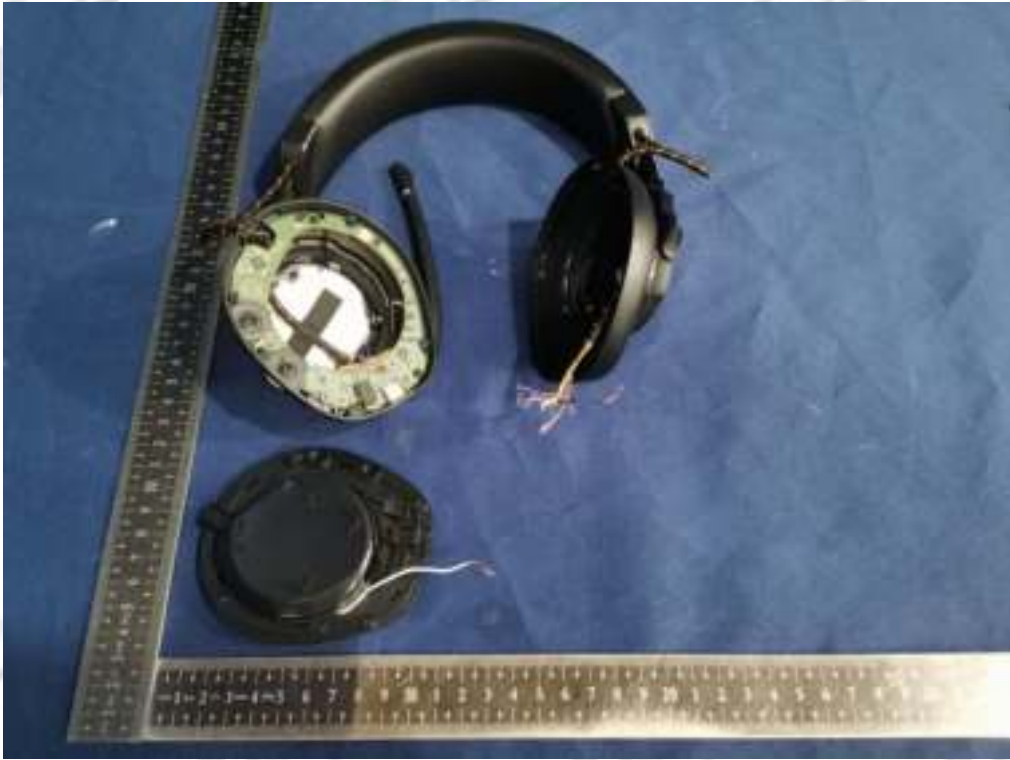

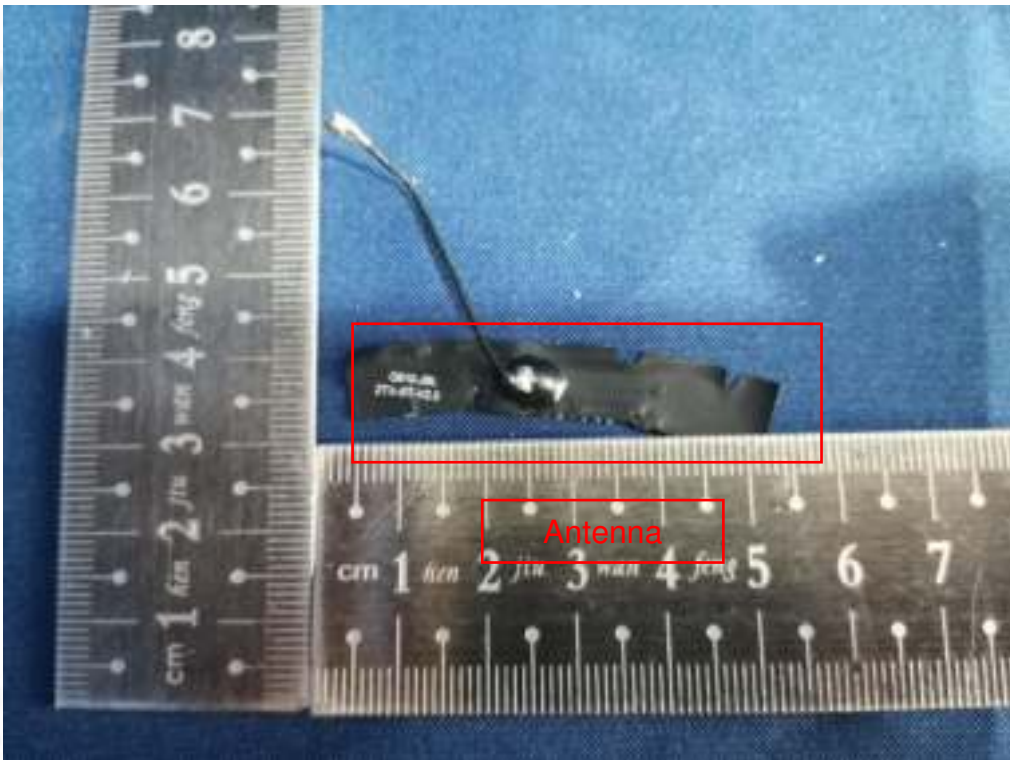

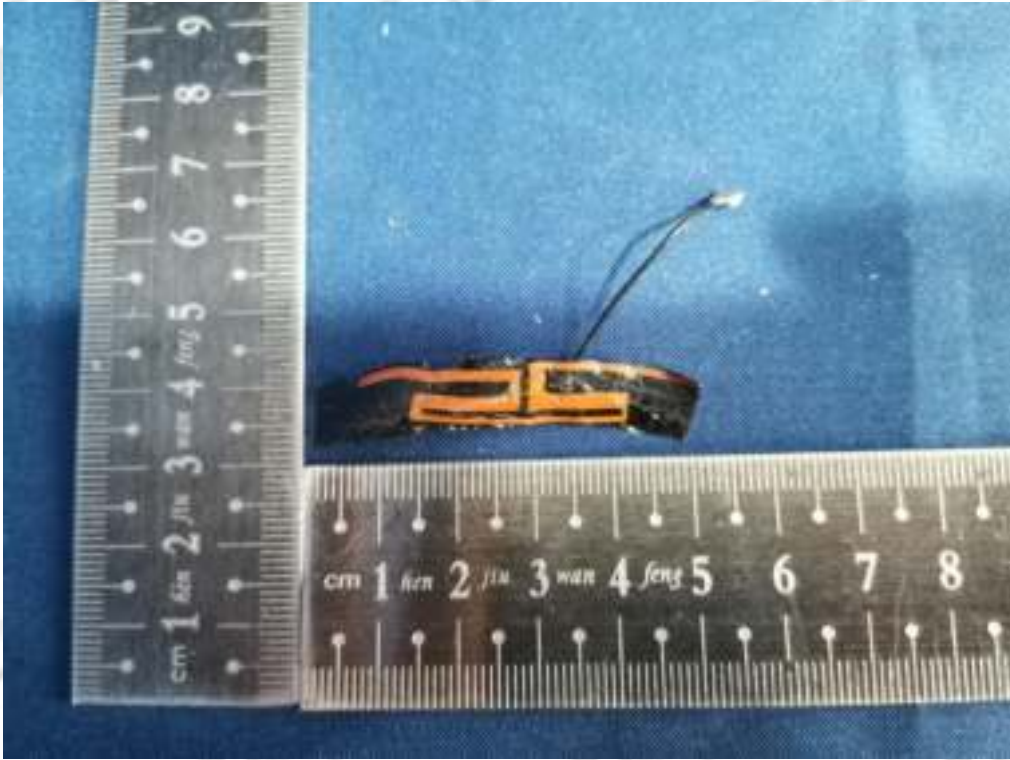



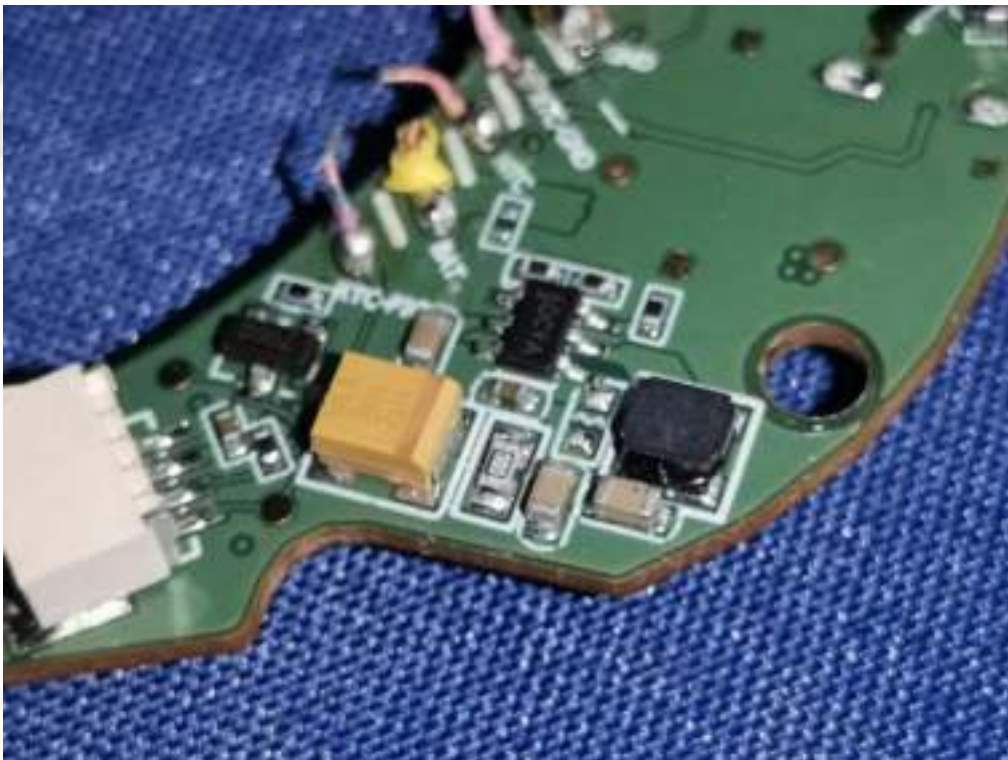
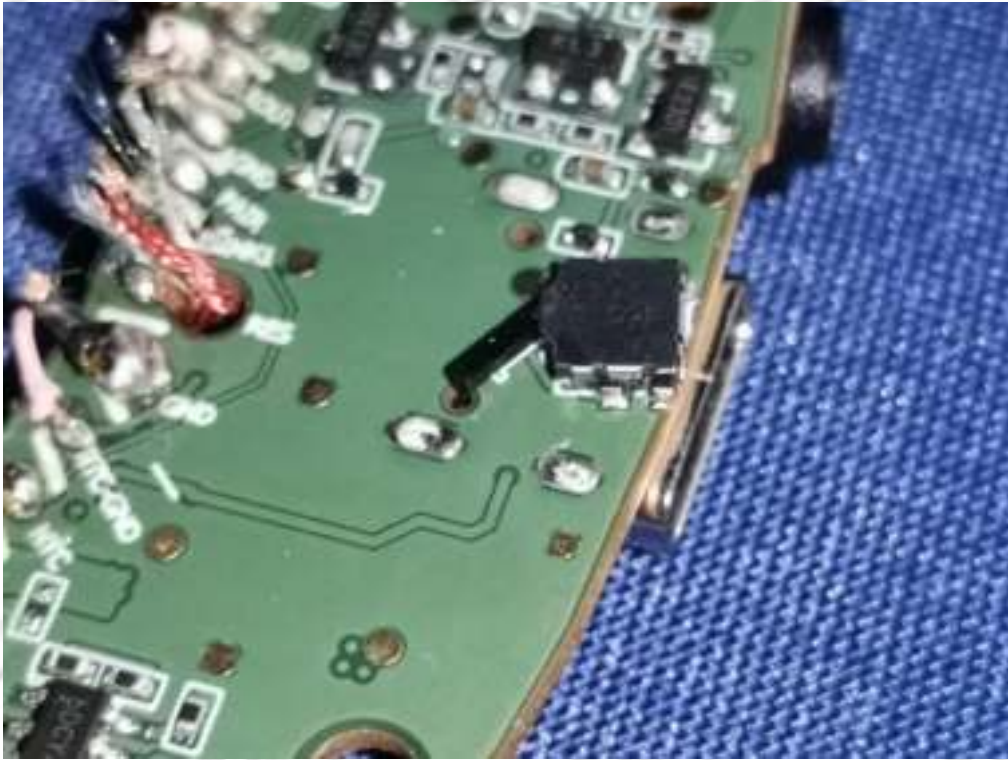

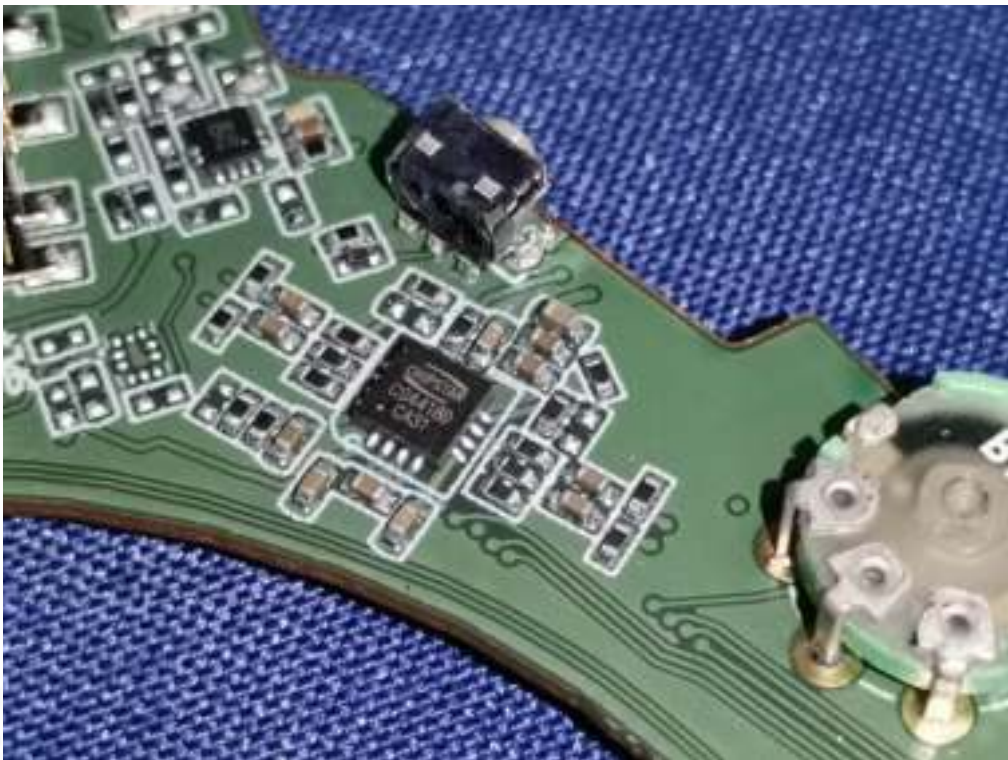
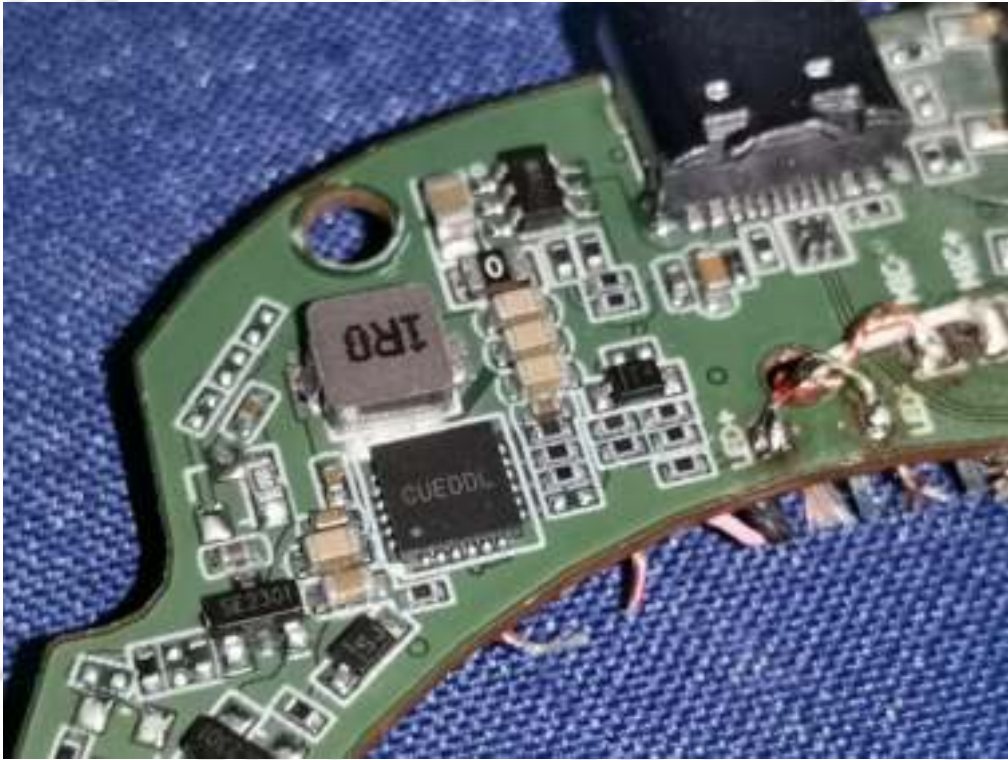

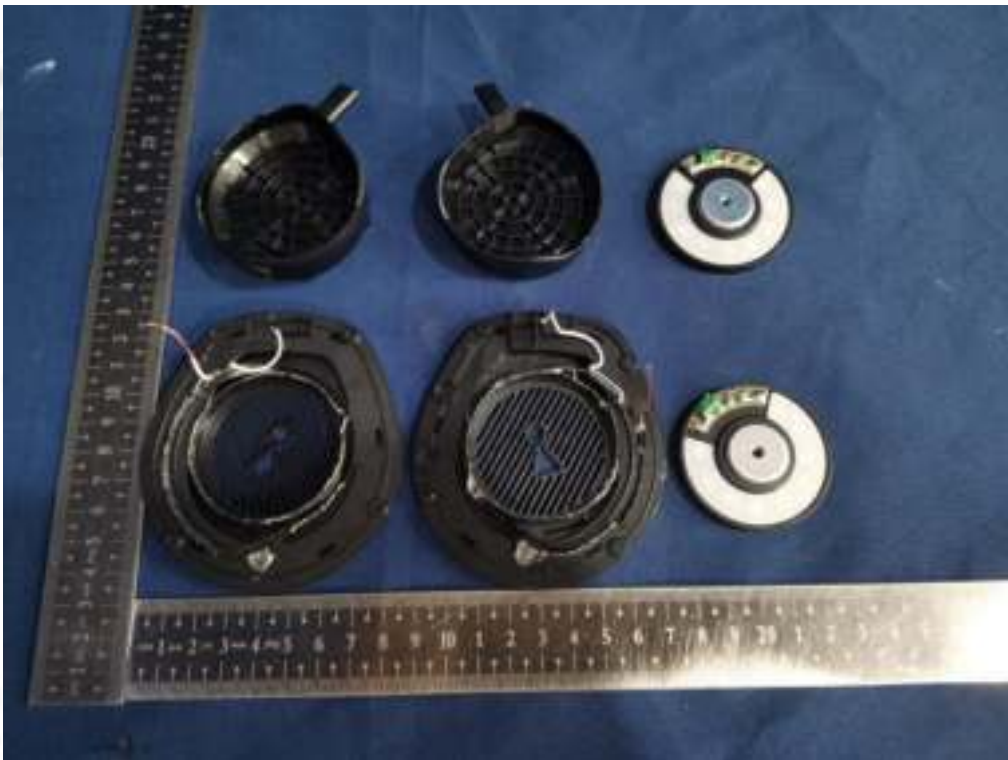
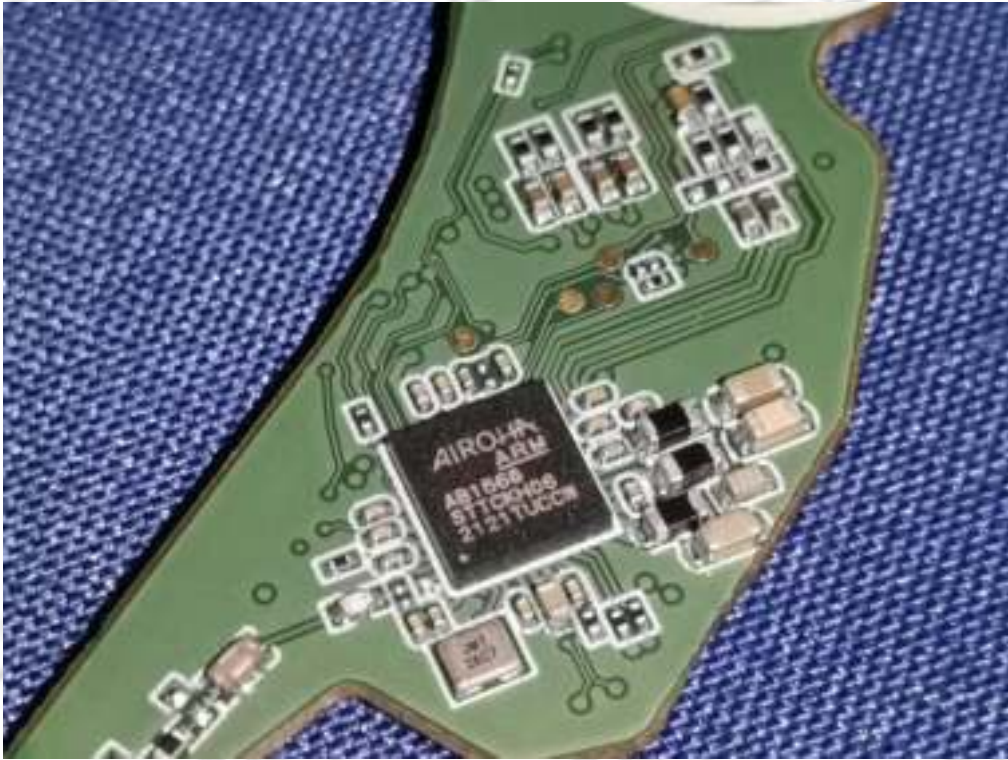



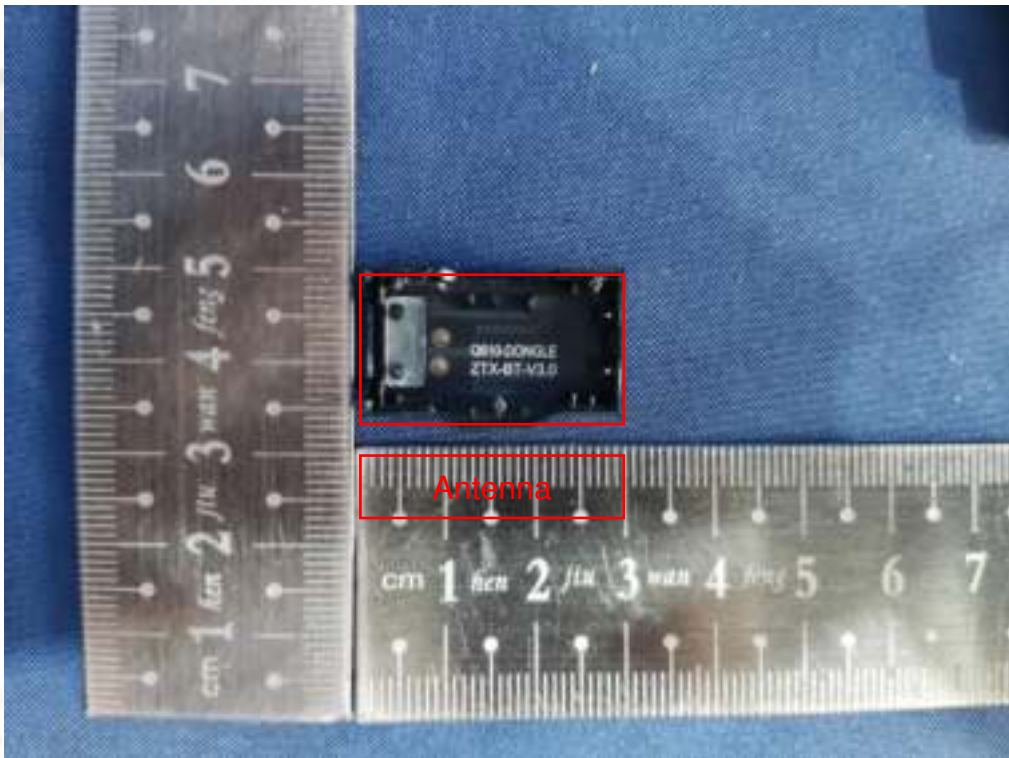
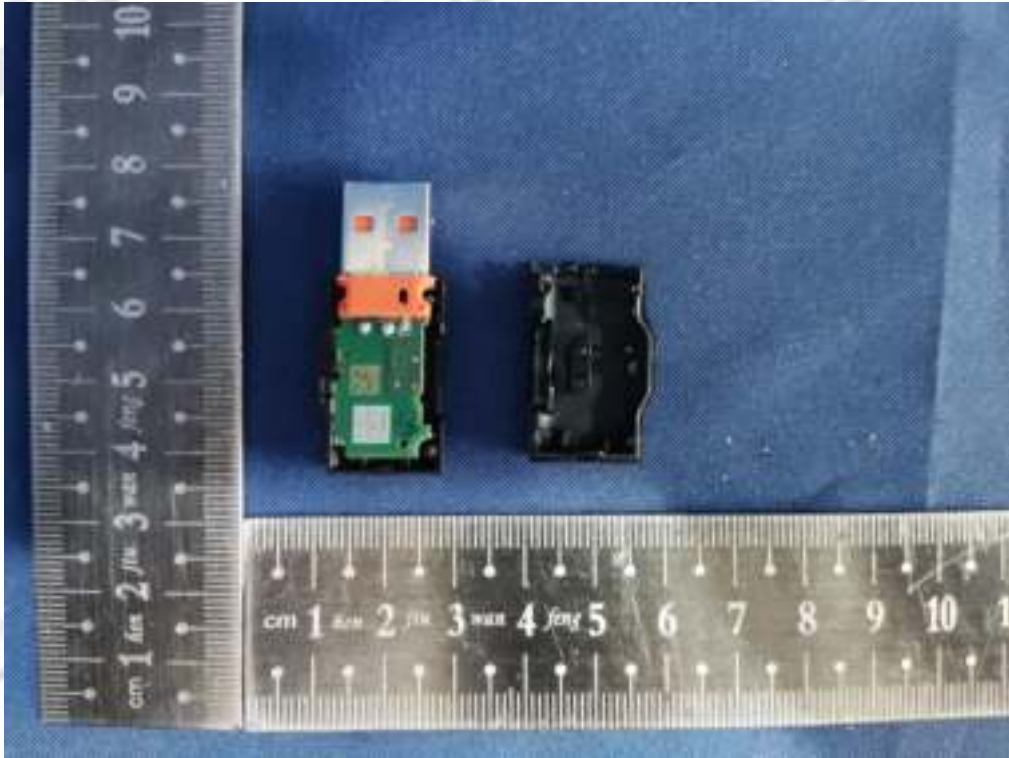

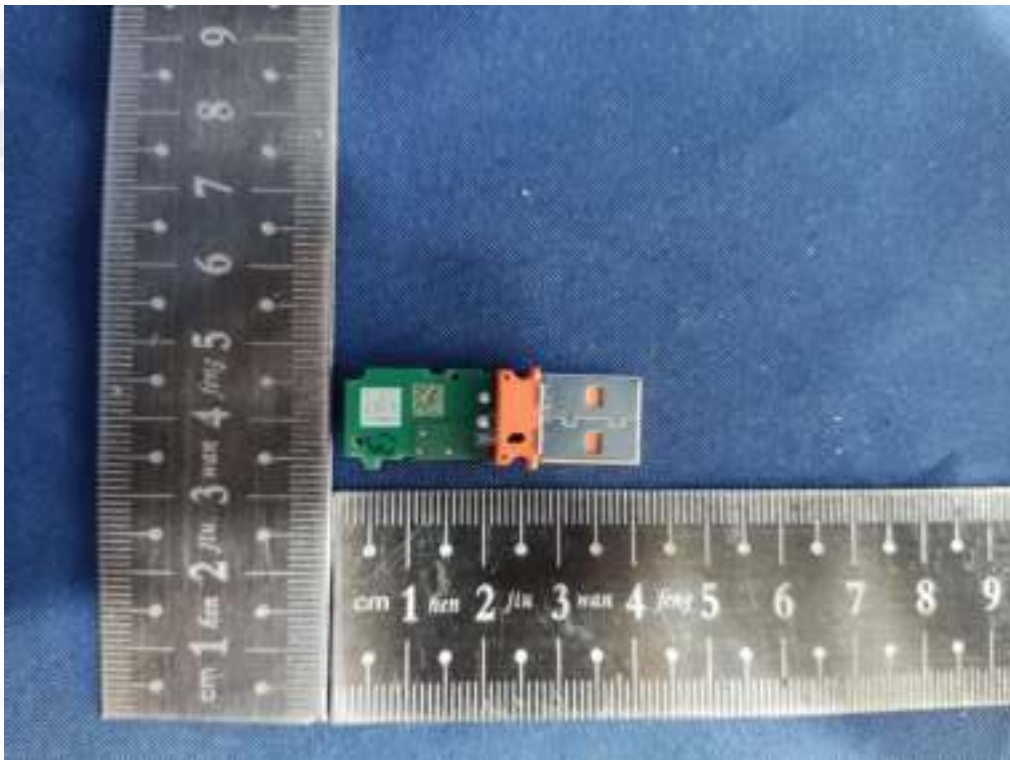
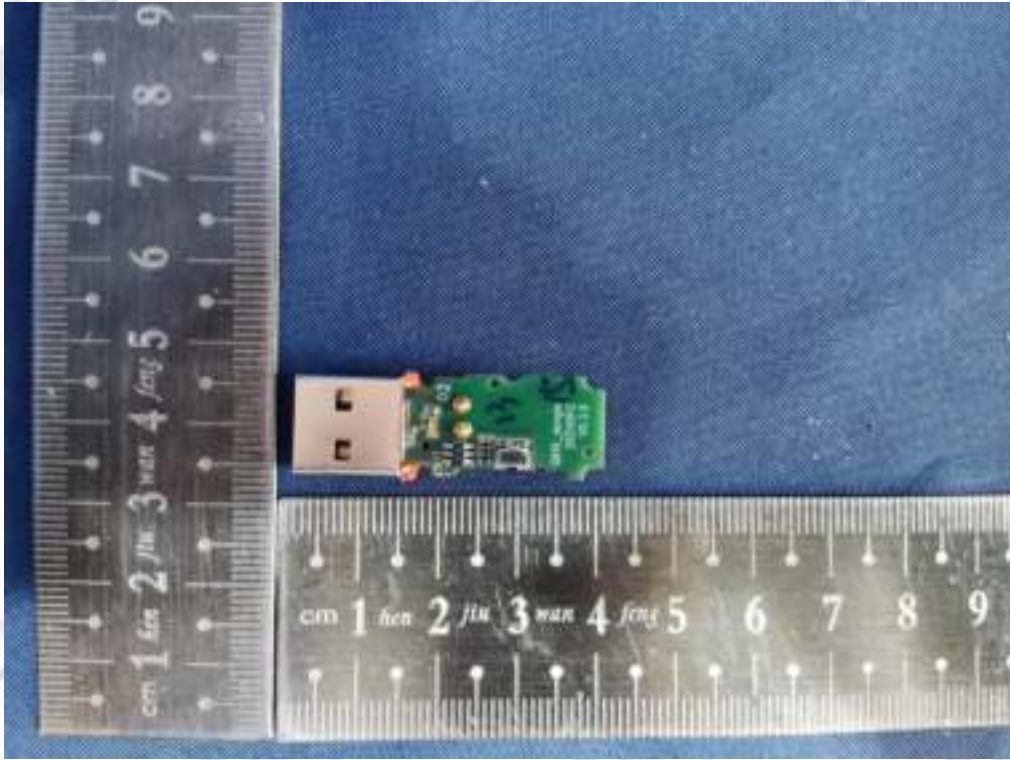

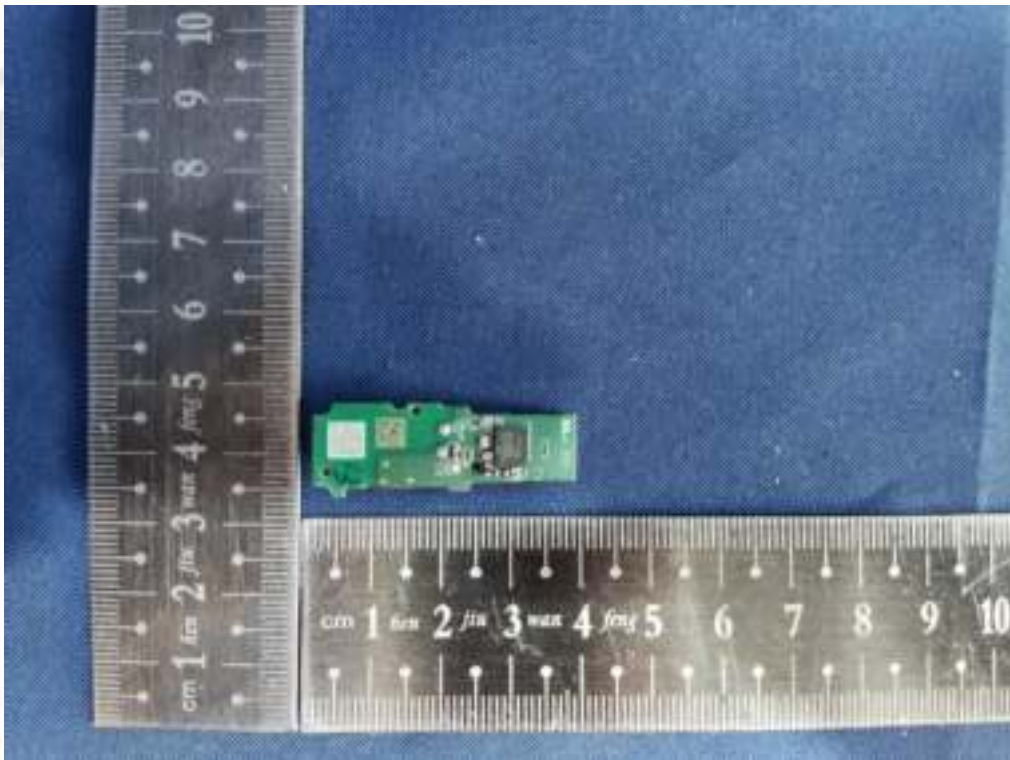
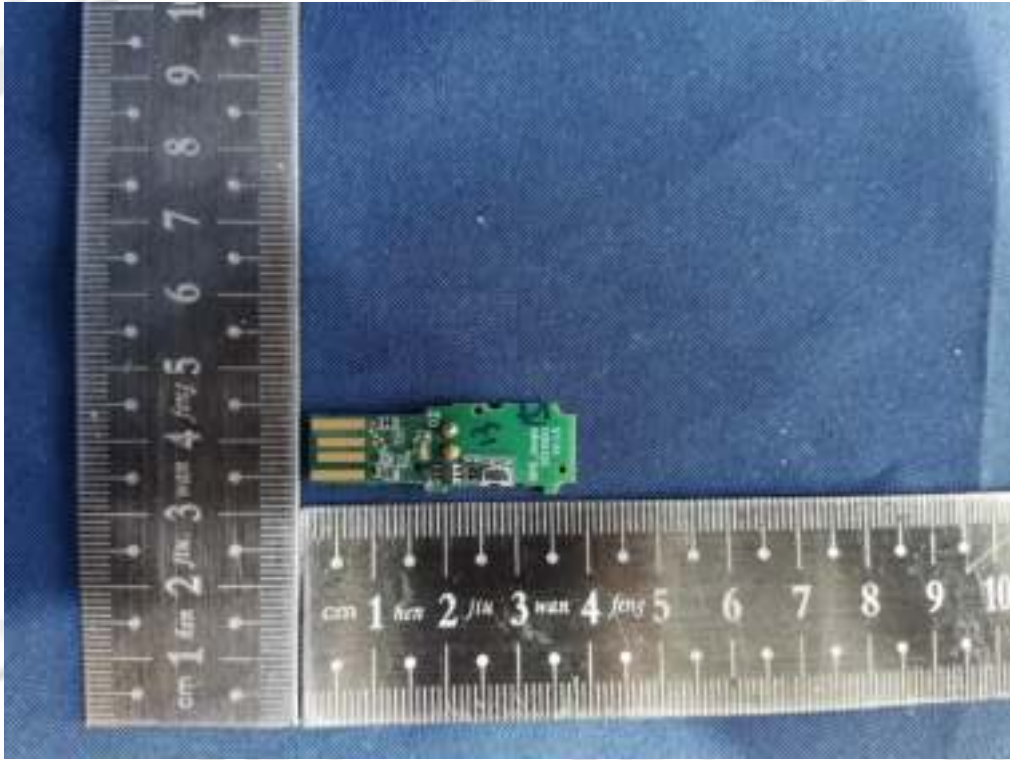

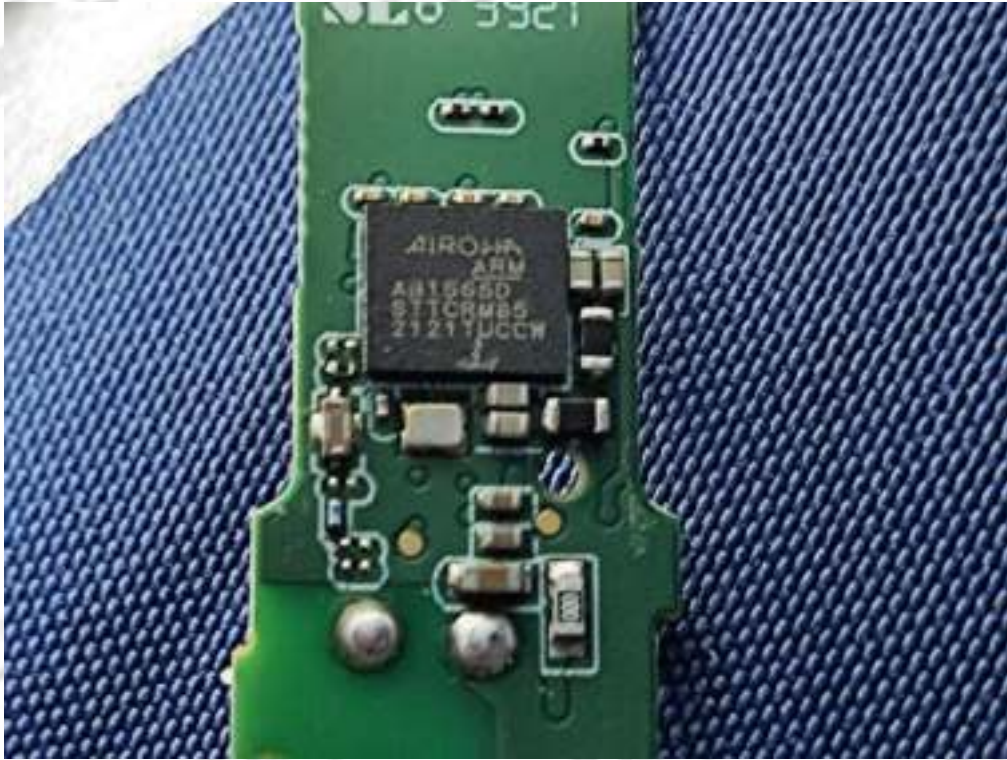

END OF REPORT