

POST INSTALLATION

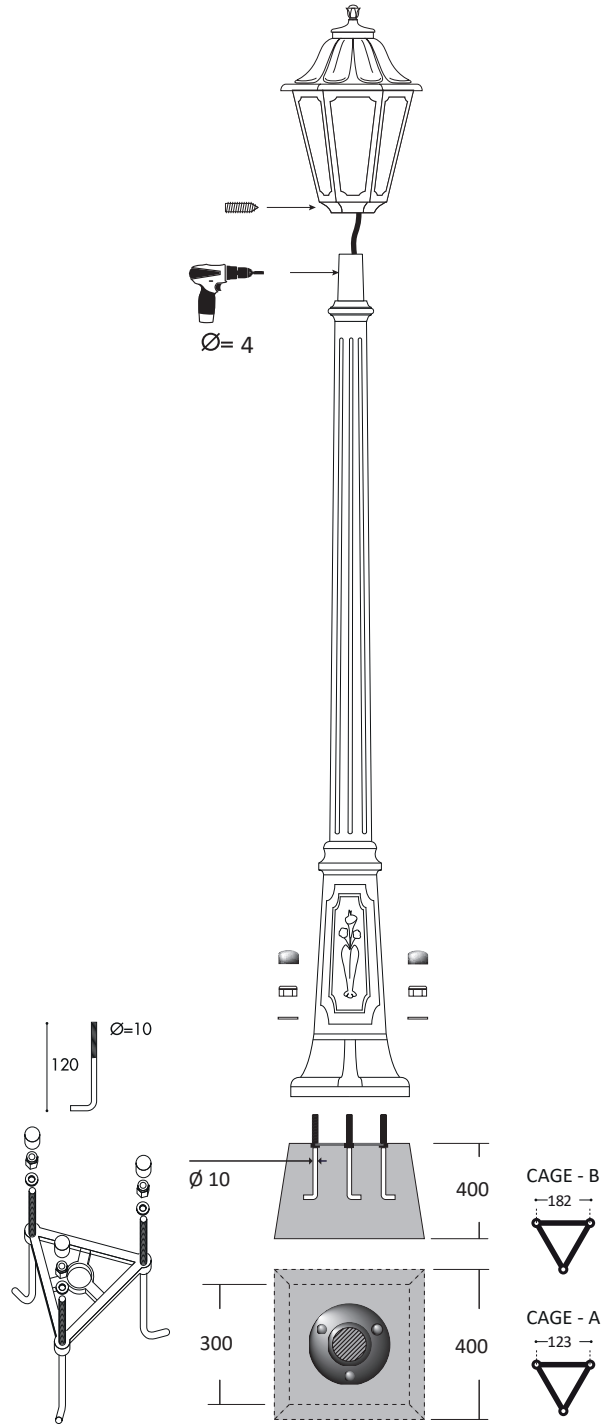

SYSTEM INSTALLATION

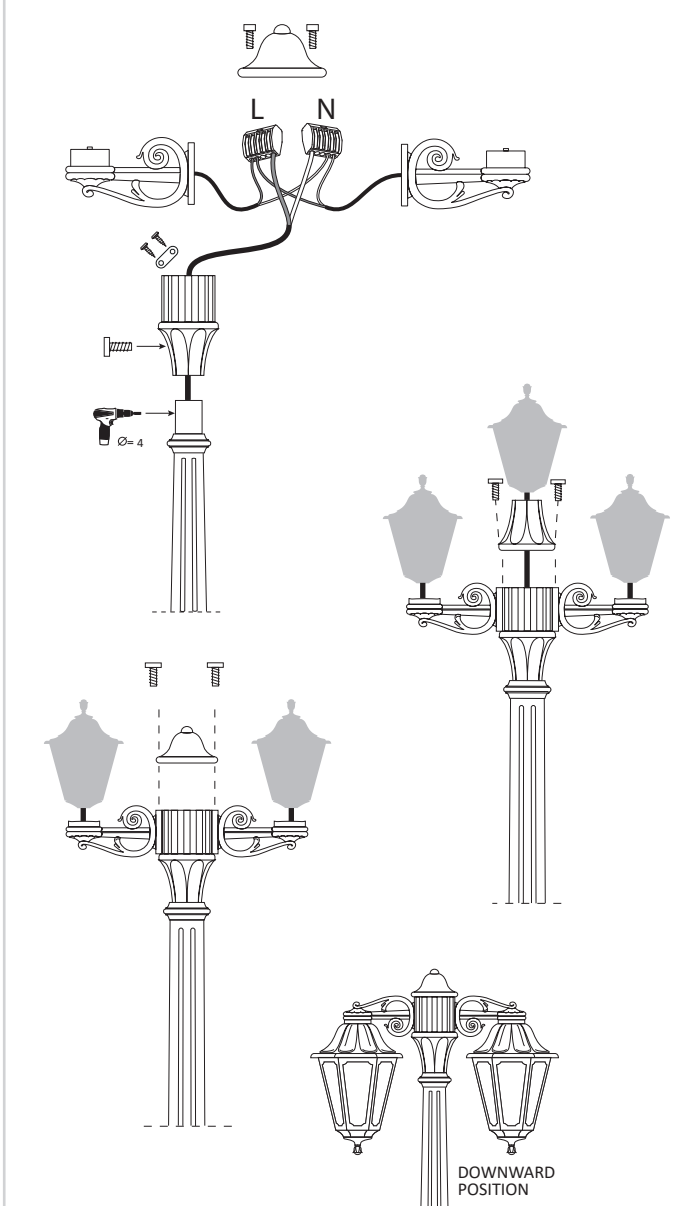

[WARRANTY] Fumagalli products are CE marked. Declaration CE of conformity available at www.fumagalli.it/company. The warranty of Fumagalli product is of 1 year. In case of evident manufacturing faults, Fumagalli Srl according to his unquestionable judgement, will proceed to the repair or the replacement. This warranty does not cover any cost neither regarding the transport, nor the uninstallation, nor the re-installation, nor the dismantlement of the material.









[GARANZIA] I prodotti Fumagalli sono marchiati CE. La Dichiarazione CE di conformità è disponibile su www.fumagalli.it/company. I prodotti Fumagalli godono di una garanzia di legge di 1 anno. Nel caso di evidenti difetti di fabbricazione Fumagalli Srl, a suo insindacabile giudizio, procederà alla sua riparazione o sostituzione. In nessun caso l'acquirente potrà reclamare rimborsi o spese sostenute per l'installazione, la disinstallazione, il trasporto o lo smaltimento del materiale.



SMALL-MEDIUM LANTERN

VERSIONS:
E27



 ANNA E22.000	310	 SABA K22.000	320	 RUT E26.000	410	 SALEM K26.000	410
 GOLIA Q23.000	360	 CEFA U23.000	380	 IESSE M22.000	350	 DARIA M28.000	515

CAUTION! Installation and maintenance procedures must be carried out only after switching off the electricity supply. Fumagalli Srl accepts no responsibility whatsoever for damages caused by incorrect installation, misuse or when used by combining it with non-original spare parts. If in doubt, consult a qualified electrician. Keep the instructions.

ATTENZIONE! L'installazione e la manutenzione dell'apparecchio devono essere eseguite solo dopo aver disinserito l'energia elettrica. Fumagalli Srl non accetta responsabilità per danni causati da incorretta installazione, incorretto uso o dall'utilizzo di parti di ricambio che non appartengono al prodotto originale. Per qualsiasi dubbio, consultare un elettricista qualificato. Conservare le istruzioni.

ATTENTION! Les opérations de montage et d'entretien ne doivent être effectués que lorsque le courant électrique est coupé. Fumagalli Srl n'accepte pas aucun responsabilité pour toutes les dommages causés par une mauvaise installation, par un' utilisation incorrecte or par l'utilisation des pièces de rechange qui ne sont pas originales. En cas de doutes, faites appel à un électricien qualifié. Conserver les instructions.

PRECAUCIÓN! Lleve a cabo la instalación y mantenimiento tras cortar la tensión de la instalación eléctrica. En cualquier caso Fumagalli Srl no aceptará responsabilidad alguna por instalación incorrecta, mal uso o por su uso con accesorios no originales del fabricante. En caso de duda consulte con un electricista cualificado. Guarde estas instrucciones.

تحذير! إجراءات التركيب والصيانة يجب تنفيذها إلا بعد إيقاف تشغيل التيار الكهربائي. الشركة المصنعة فوماجالي لا تقبل أي مسؤولية عن الأضرار الناجمة عن التركيب غير الصحيح , سوء الاستخدام , أو عند استخدام قطع غير أصلية عند الجمع. إذا إنتابك أي شك , قم باستشارة كهربائي مختص , قم بتتبع التعليمات.

LANTERN UPWARD position

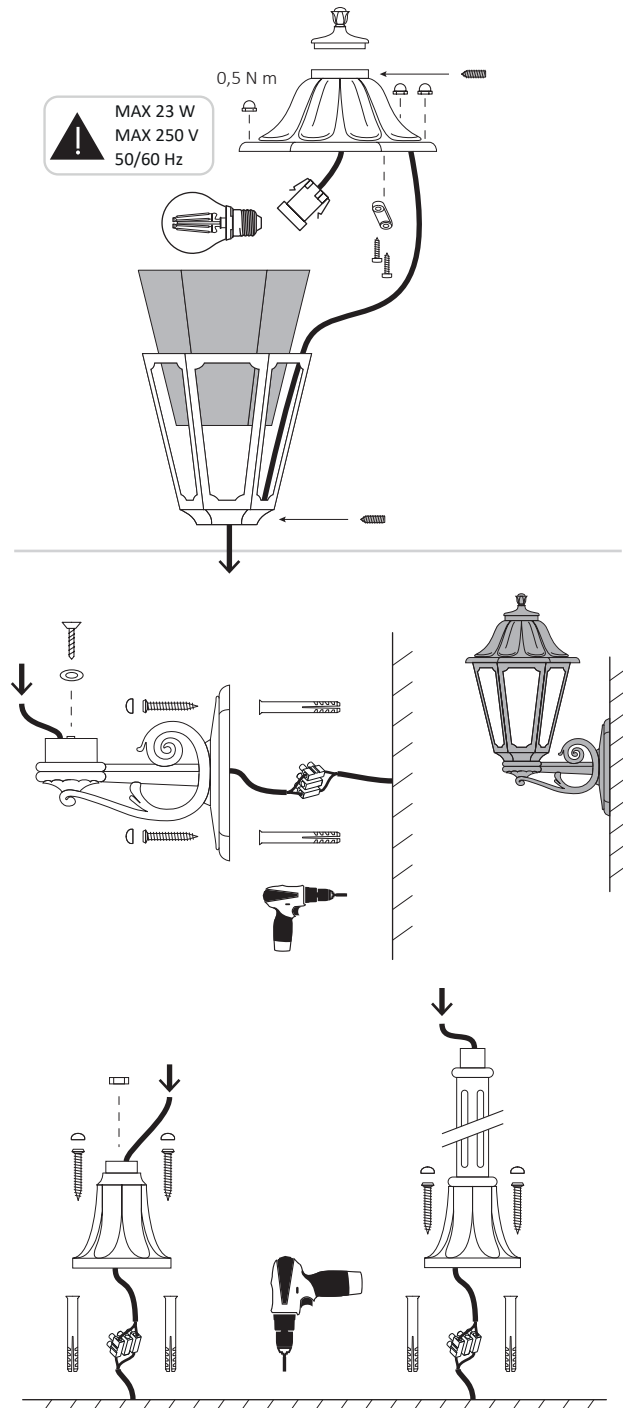

LANTERN DOWNWARD position

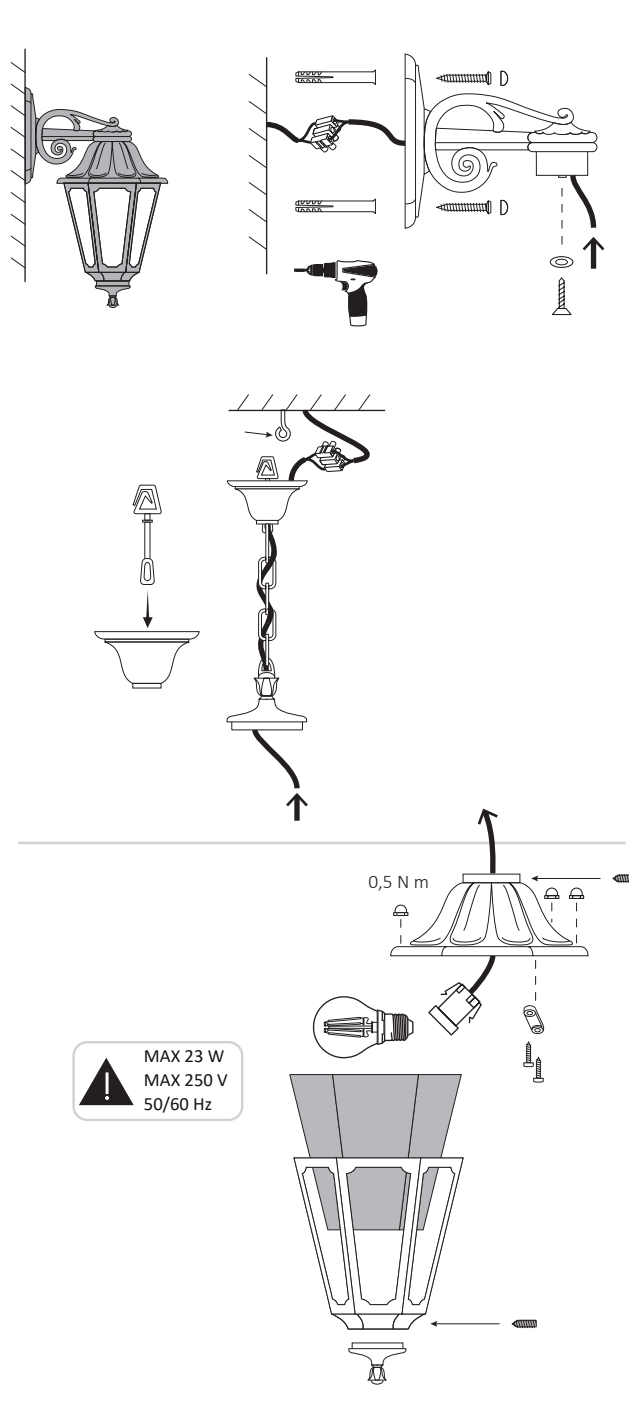

HALF LANTERN

