

639-0

07/19

Montageanleitung

(bitte zusammen mit Kaufbeleg aufbewahren)

Assembly instructions

(please retain and file together with the purchase receipt)

Notice de montage

(à conserver et à accrocher impérativement avec le justificatif d'achat)

Montagehandling

(samen met de aankoopfactuur in ieder geval bewaren)

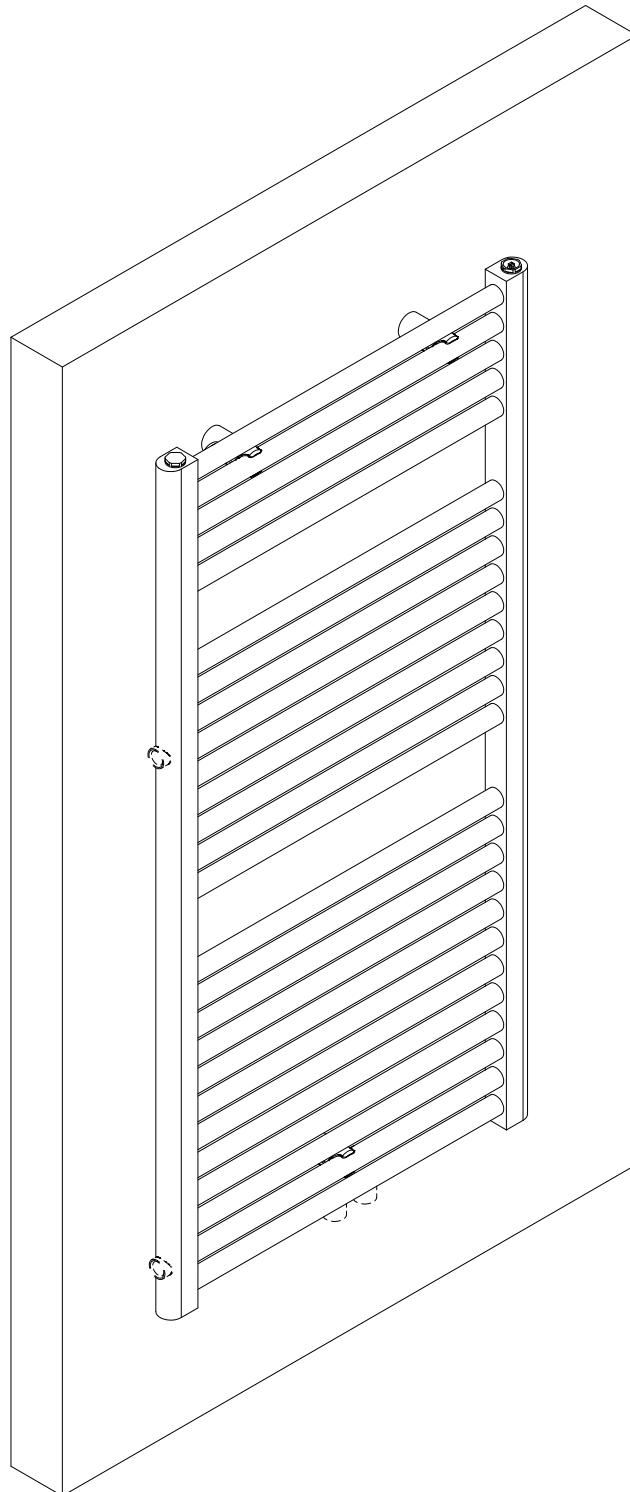

- Ⓓ Produktübersicht Sonderfarben
- ⒼⒷ product overview special colors
- Ⓕ Aperçu produit couleurs spéciales
- ⒼⓃ productoverzicht speciale kleuren

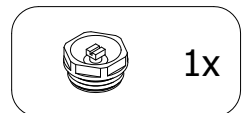
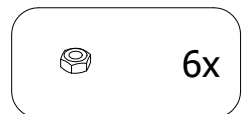
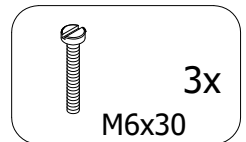
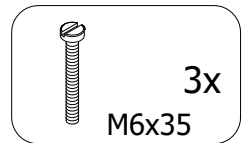
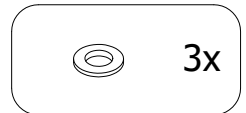
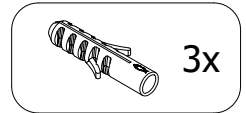
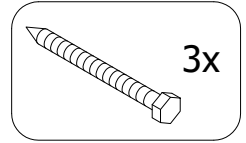
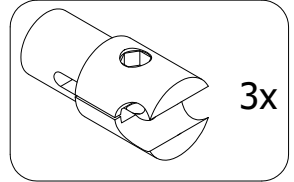
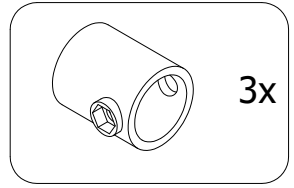
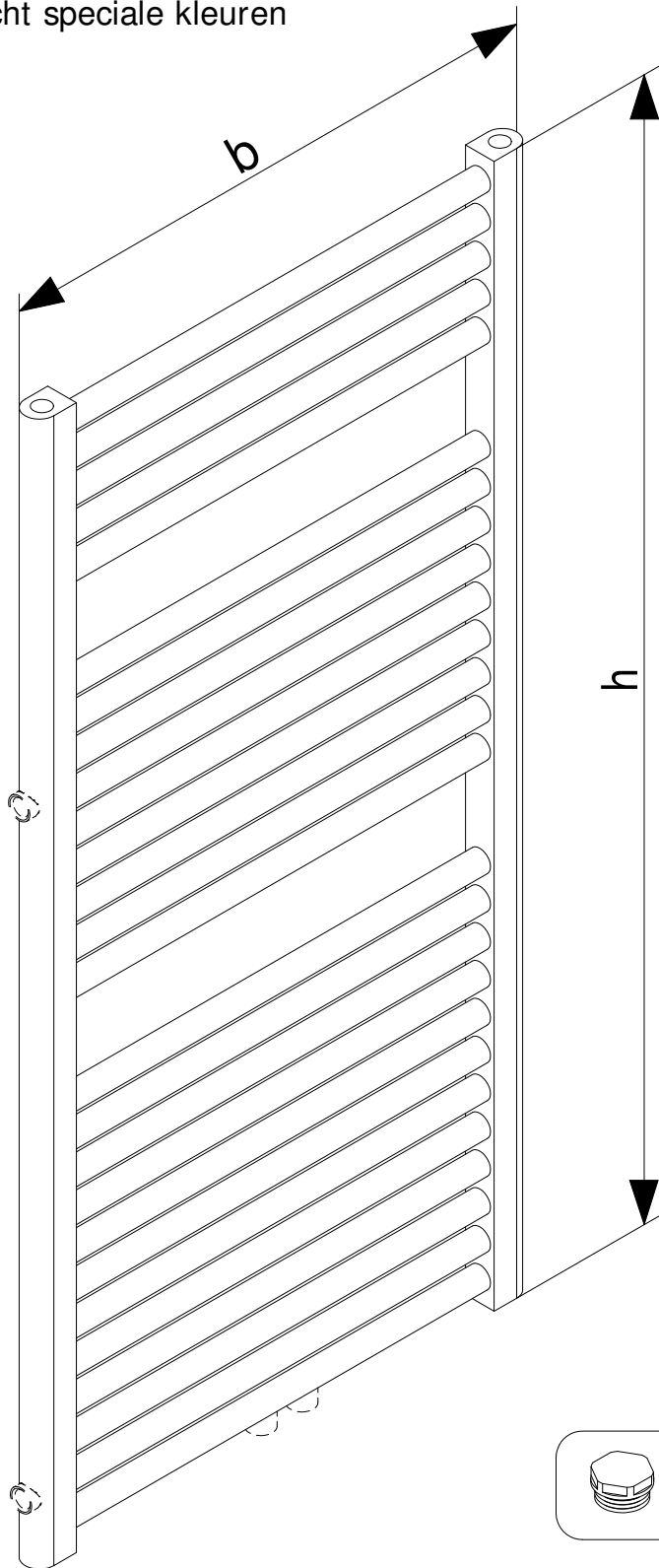

oder
or
ou
of

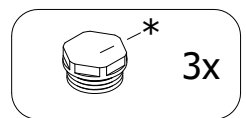

Benötigtes Werkzeug / Tool needed / outillage nécessaire / Benodigd gereedschap

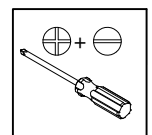
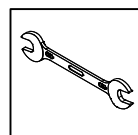
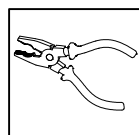
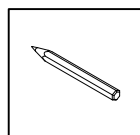
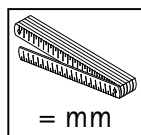
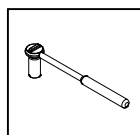
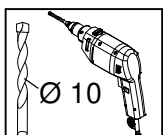
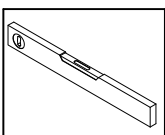

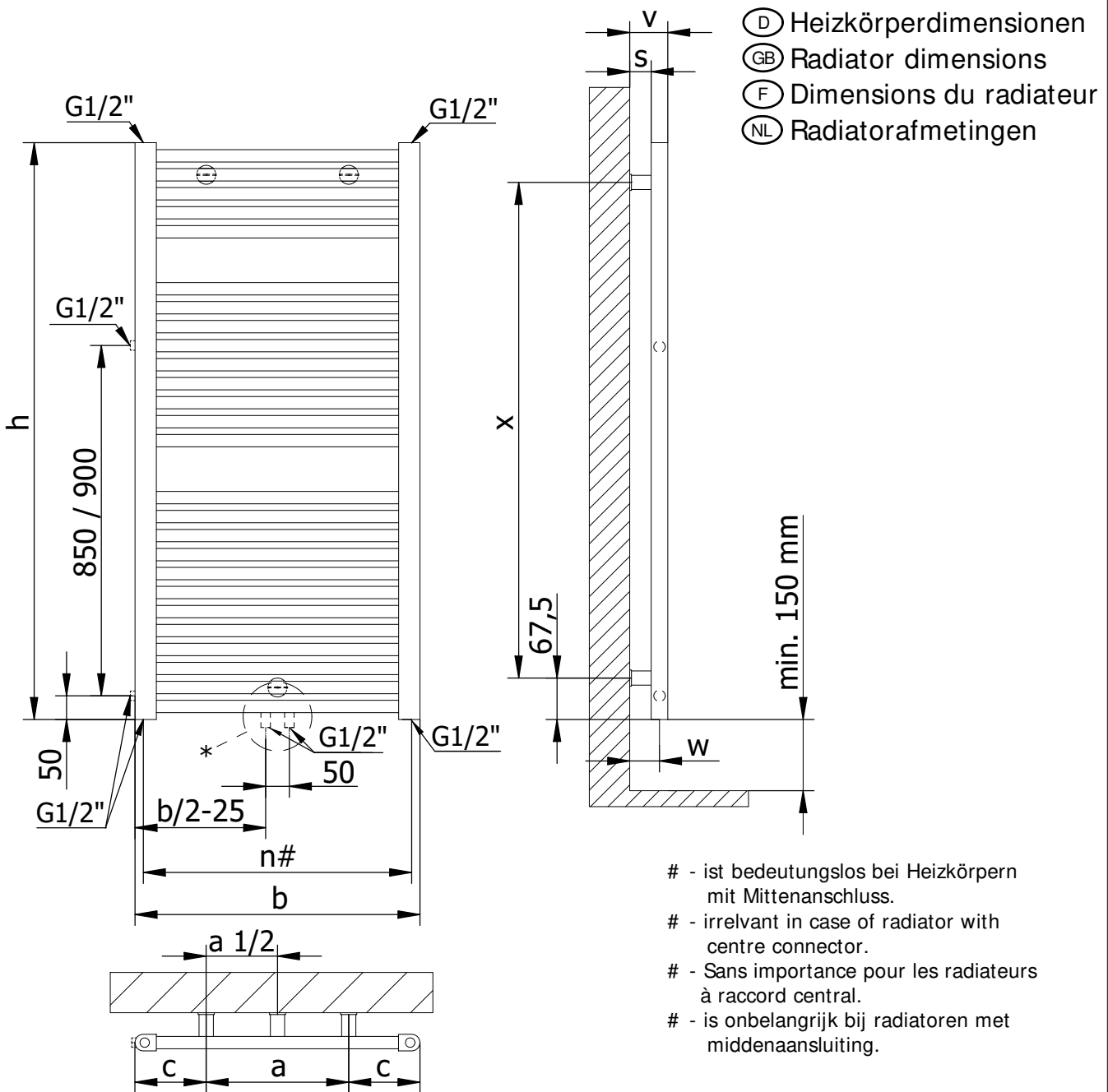

- # - ist bedeutungslos bei Heizkörpern mit Mittenanschluss.
- # - irrelevant in case of radiator with centre connector.
- # - Sans importance pour les radiateurs à raccord central.
- # - is onbelangrijk bij radiatoren met middenaansluiting.

- * - Nur bei Heizkörpern mit Mittenanschluss.
- * - only radiators with center connection.
- * - Uniquement pour les radiateurs à raccord central.
- * - alleen bij radiatoren met middenaansluiting.

- LG** = Leergewicht, empty weight, poids à vide, leeggewicht,
- F** = Füllvolumen, filling volume, volume de remplissage, vulhoeveelheid,

h	b	n#	a	c	x	w	s	v	LG (kg)	F (L)	Watt
775	400	359	100	150	640	69-79	51-61	86-96	6,4	4,1	361
775	500	459	200	150	640	69-79	51-61	86-96	7,7	4,8	451
730	500	459	200	150	595	69-79	51-61	86-96	6,6	4,1	263
775	600	559	300	150	640	69-79	51-61	86-96	9,0	5,5	532
730	600	559	300	150	595	69-79	51-61	86-96	7,7	4,8	308
1215	500	459	200	150	1080	69-79	51-61	86-96	11,8	7,4	678
1180	500	459	200	150	1045	69-79	51-61	86-96	10,5	6,6	405
1215	600	559	300	150	1080	69-79	51-61	86-96	13,8	8,6	800
1180	600	559	300	150	1045	69-79	51-61	86-96	12,1	7,6	474
1215	750	709	450	150	1080	69-79	51-61	86-96	16,7	10,3	982
1575	500	459	200	150	1440	69-79	51-61	86-96	17,0	9,5	837
1775	500	459	200	150	1640	69-79	51-61	86-96	17,2	10,8	958
1775	600	559	300	150	1640	69-79	51-61	86-96	20,1	12,9	1129
1765	600	559	300	150	1630	69-79	51-61	86-96	18,1	11,4	681
1775	750	709	450	150	1640	69-79	51-61	86-96	24,4	15,0	1386

1

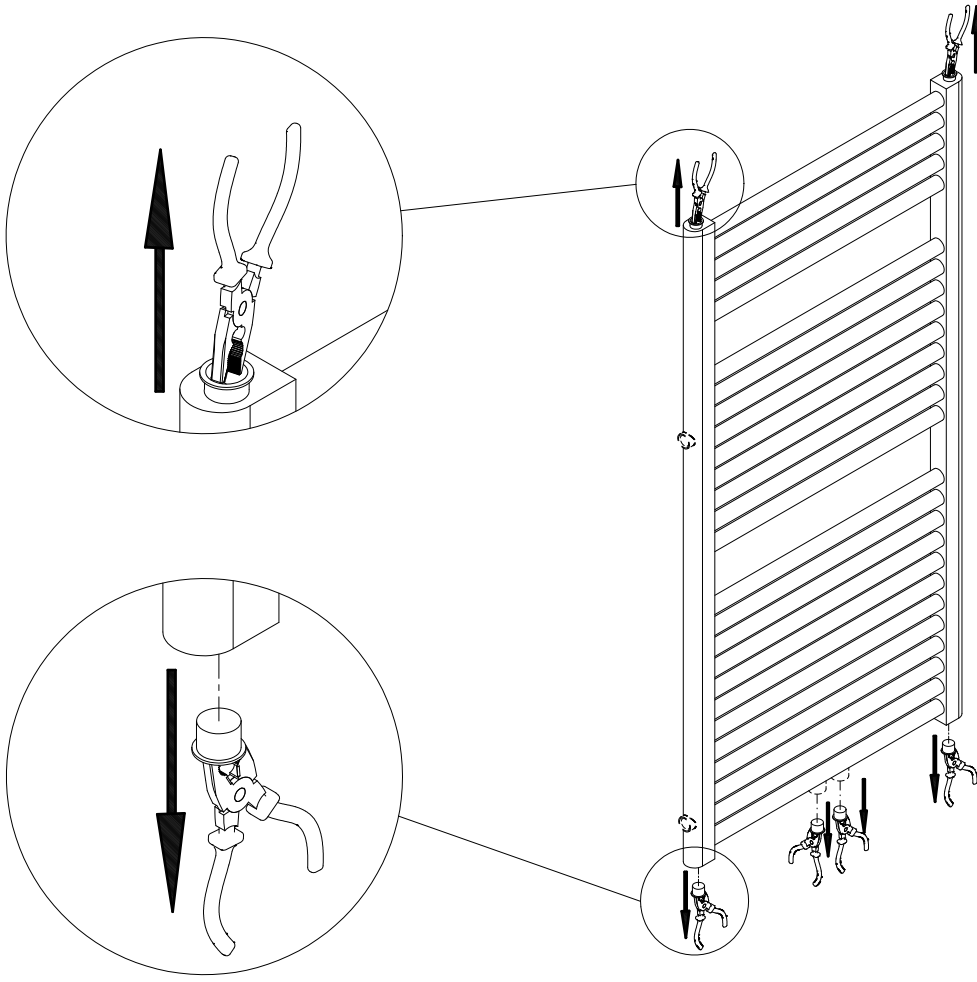

2

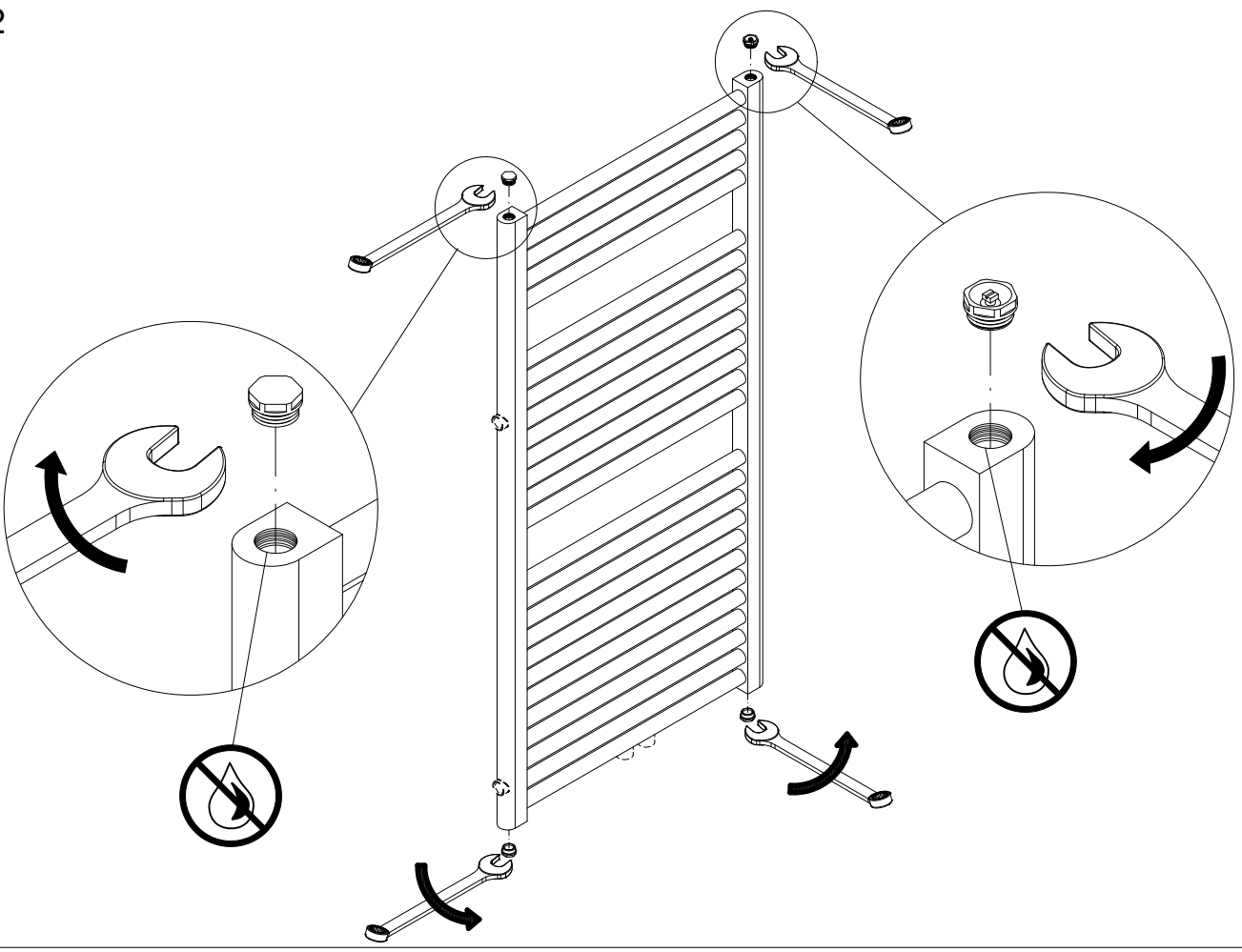

3

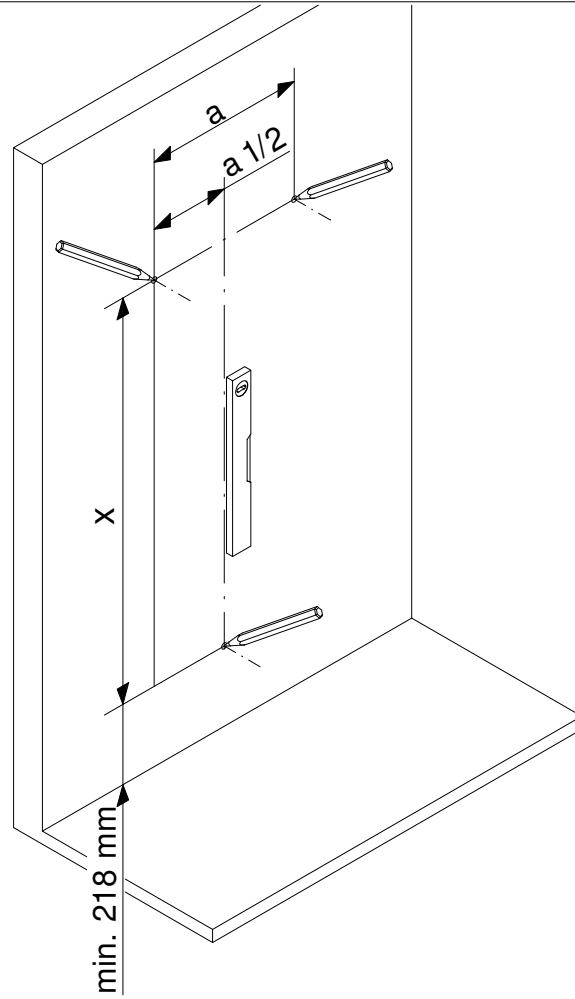

4

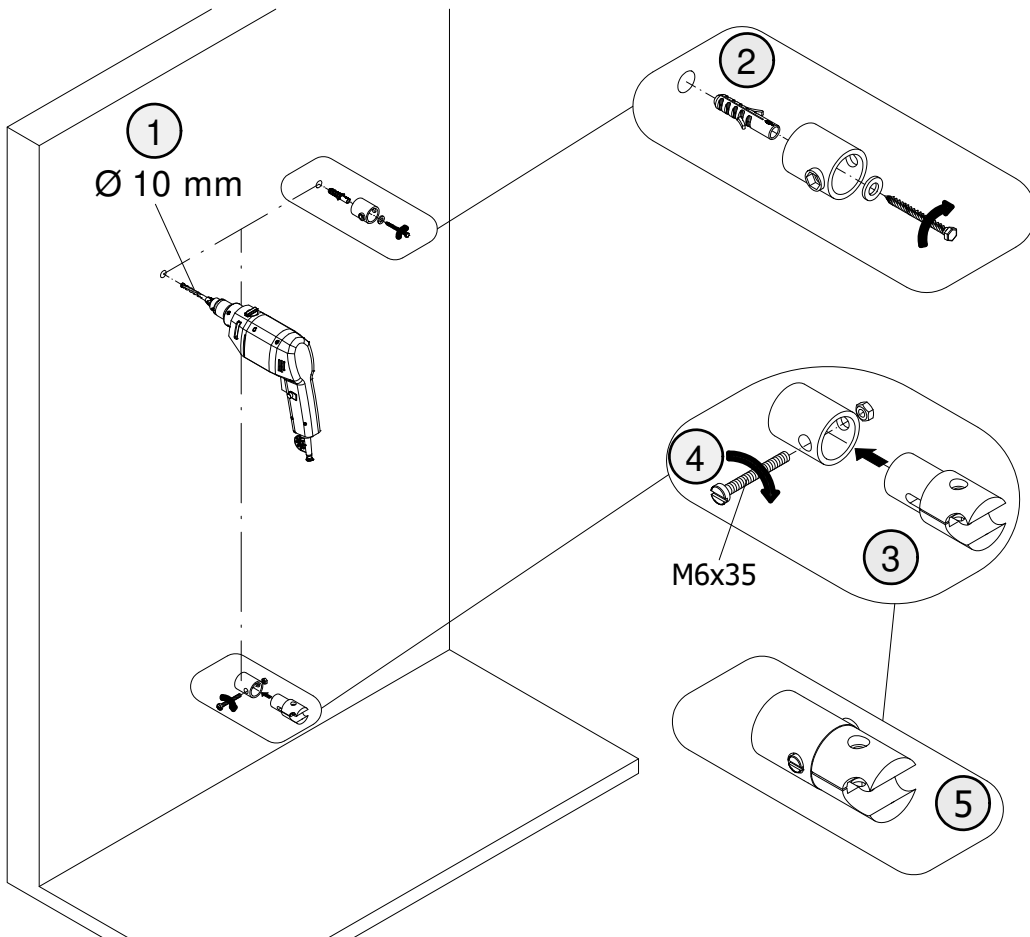

5

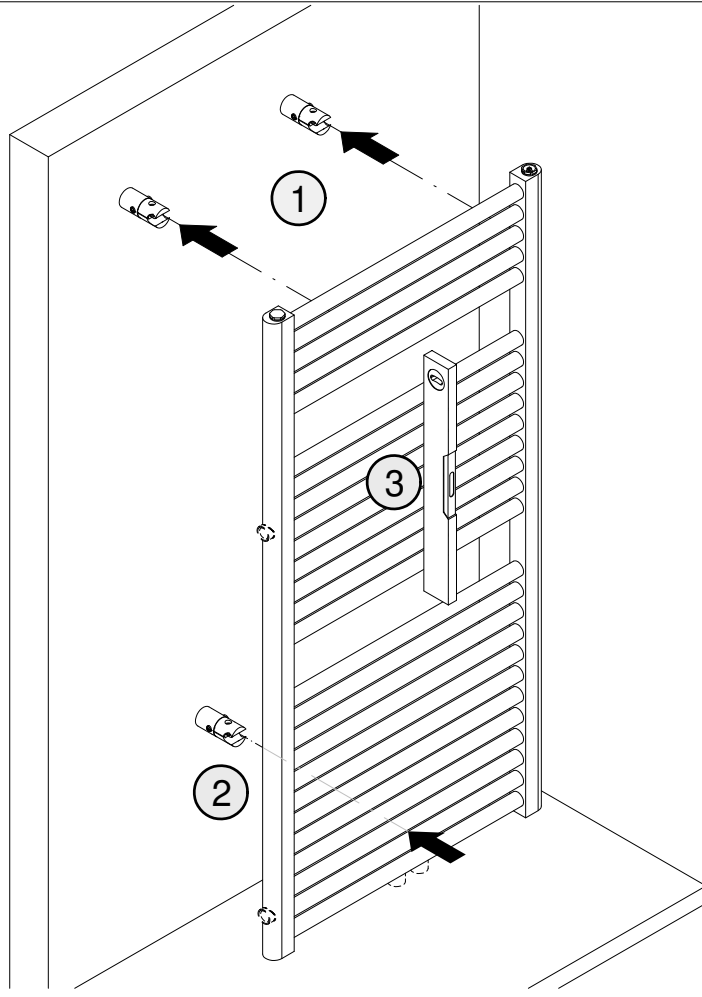

6

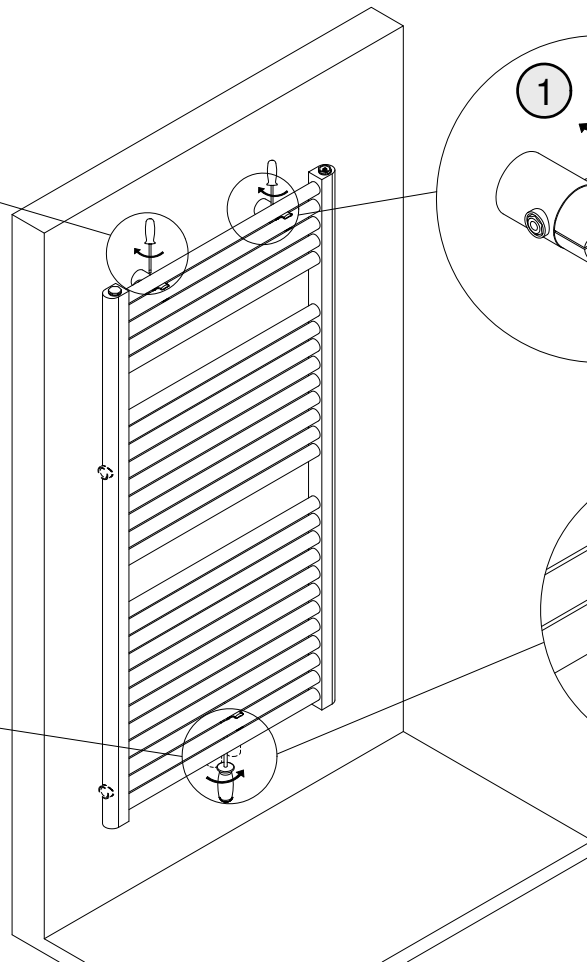
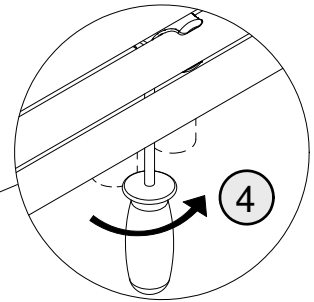
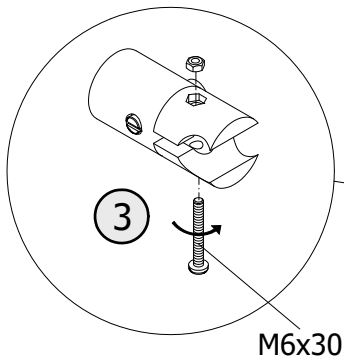
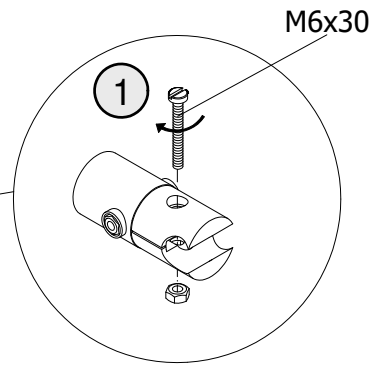
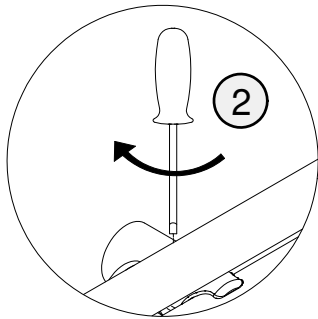





FAQ

Störung	Ursache	Fehlersuche (Eingrenzung)	Abhilfe
Der Heizkörper wird nicht oder nur leicht warm.	gestörte Zirkulation	Luft im Heizkörper Anschlussituation (Vorlauf / Rücklauf) Heizkörper ist unterversorgt	Entlüften Sie den Heizkörper. Prüfen Sie, ob der Vorlauf / Rücklauf korrekt angeschlossen ist. Führen Sie einen hydraulischen Abgleich durch.
Der Heizkörper macht Geräusche.	gestörte Zirkulation Anlagendruck / Versorgungsleistung gestört	Luft im Heizkörper Ventil regelt nicht Voreinstellung der Ventile	Entlüften Sie den Heizkörper. Prüfen Sie die Ventile und den Thermostatkopf. Führen Sie einen hydraulischen Abgleich durch.
Der Heizkörper knackt in der Aufheiz- und Abkühlphase.	Ausdehnungsgeräusche bei Temperaturanstieg- bzw. Abfall, Spannungen im System		Hier liegt keine Gefahr vor und es ist keine Handlung erforderlich.
Der Heizkörper weist Mängel in der Montage oder in der Optik auf.			Wenden Sie sich an den Vertreter des Produktes.
Der Heizkörper soll mit einem Heizkostenverteiler ausgestattet werden.			Wenden Sie sich an den Hersteller des Heizkostenverteilers.

Problem	Reason	Trouble-shooting	Remedy
The radiator is luke warm	circulation blocked	Air in the radiator Connection issue (reverse in/out flow) Radiator needs bleeding	Bleed the radiator Check the non return valve is connected properly Perform a hydraulic balancing
The radiator makes unusual noises	circulation blocked system pressure incorrect - adjust accordingly	Air in the radiator Valve not regulating Faulty valves	Bleed the radiator Check the valves and thermostatic control Perform a hydraulic balancing
The radiator "pulses" in the heating and cooling mode.	Expansion noises when using a heating rod or particles are circulating in the system.		Here, there is no risk and no action required.
The radiator has visual impairments/defects			Please contact the retailer of the product.
The radiator should be equipped with a thermostatic control or heating rod.			Contact the manufacturer of the thermostatic control or heating rod.

Dysfonctionnement	Cause(s)	Détection des erreurs	Solution(s) Proposée(s)
Le radiateur ne chauffe pas ou très peu.	circulation bloquée	présence d'air dans le radiateur problème de connexion du circulateur alimentation insuffisante	purger le radiateur. vérifier si le clapet de retenue a été installé correctement. effectuer un équilibrage hydraulique.
Le radiateur fait un bruit anormal.	circulation bloquée pression / alimentation incorrecte	présence d'air dans le radiateur la vanne thermostatique ne régule pas. paramétrage de la vanne thermostatique.	purger le radiateur. vérifier la vanne et la tête thermostatique. effectuer un équilibrage hydraulique.
Craquement lors de la chauffe ou refroidissement du radiateur.	Bruits provoqués par la dilatation des tuyaux lors de la chauffe, refroidissement, ou par des tensions au coeur du système.		Aucun danger, aucune action n'est nécessaire.
Le radiateur présente un défaut technique ou optique.			Prendre contact avec votre revendeur.
Le radiateur doit être équipé d'un système de répartiteur de frais de chauffage.			Prendre contact avec votre fournisseur d'énergie.

storing	oorzaak	storingzoeken (beperking)	oplossing
De radiator wordt niet of slechts gedeeltelijk warm.	onderbroken circulatie	lucht in de radiator verwisseling aanvoer/retour) watertoevoer naar radiator is te gering	ontlucht de radiator. controleer of aanvoer/retour juist is aangesloten. maak een hydraulisch vergelijk.
De radiator maakt geruis.	gestoorde circulatie installatiedruk / verzorgingscapaciteit onvoldoende	lucht in de radiator radiatorkraan regelt niet juist. voorstelling van radiatorkraan niet juist.	ontlucht de radiator. controleer de radiatorkraan en thermostaatkop. maak een hydraulisch vergelijk.
De radiator "knakt" bij het warmworden en afkoelen.	Uitzettingsgeluiden bij temperatuurstijging resp. afkoeling, spanning in het systeem.		Hier bestaat geen gevaar en is geen ingreep noodzakelijk.
De radiator heeft onvolkomenheden bij de montage of optisch.			Neem contact op met de verkoper van het product.
De radiator moet worden voorzien van een warmtekostenverdelers.			Neem contact op met de fabrikant van de warmteleverancier.

			
0626	0626	0626	0626
17 MÜNCHEN	17 MÜNCHEN	17 MÜNCHEN	17 MÜNCHEN
<p>EN 442-1 in der gültigen Fassung LE/SH-Nr.02/2019-01 Gebrauch nur in Heizungsanlagen in Gebäuden</p> <p>Feuerbeständigkeit: A1 Freisetzung gefährlicher Stoffe: keine Druckdichtigkeit: keine Undichtigkeit bei 1,3 x MB Druckfestigkeit: - kein Riss bei 1,69 x MB - Maximaler Betriebsdruck (MB) 10 bar</p> <p>Oberflächentemperatur: bis 95°C; Nennwärmeleistung: 263 - 1386 W</p> <p>Beständigkeit: Korrosionsbeständigkeit: keine Korrosion nach 100 h Feuchtigkeit Beständigkeit gegen kleinere Stoßbeschädigungen: Klasse 0</p>	<p>EN 442-1 valid version LE/SH-Nr.02/2019-01 Heating systems in buildings</p> <p>Reaction to fire: A1 Release of dangerous substance: none Pressure tightness: no leakage at 1,3 x MOP Resistance to pressure: - no breakage at 1,69 x MOP - Maximum operating pressure (MOP) 10 bar</p> <p>Surface temperature: Maximum 95°C; Rated thermal output: 263 - 1386 W</p> <p>Durability as: Resistance against corrosion: no corrosion after 100 h humidity Resistance against minor impact: Class 0</p>	<p>EN 442-1 version valable LE/SH-Nr.02/2019-01 Pour installation dans les systèmes de chauffage</p> <p>Résistance au feu: A1 Rejet de substances dangereuses : aucun Étanchéité à la pression: pas de fuite à 1,3 x PMA Résistance à la pression: - Pas de fissure à 1,69 x PMA - Pression de service Maxi. Autorisée (PMA) 10 bars</p> <p>Température de surface: jusqu'à +95°C Puissance thermique nominale : 263 - 1386 W</p> <p>Résistance: Résistance à la corrosion : aucune apparition de corrosion après 100 h de test en milieu humide Résistance aux légers impacts : Degré 0</p>	<p>EN 442-1 in de geldige versie LE/SH-Nr.02/2019-01 Gebruik alleen in verwarmingsinstallaties in gebouwen</p> <p>Vuurresistentie: A1 Vrijkomen gevaarlijke stoffen: geen Drukresistentie: geen lekkage bij 1,3 x MB Drukvastheid: - scheurt niet bij 1,69 x MB - Maximale bedrijfsdruk (MB) 10 bar</p> <p>Oppervlakte temperatuur: tot 95°C Nominale warmteafgifte: 263 - 1386 W</p> <p>Resistentie: Corrosie resistentie: geen corrosie na 100u vochtigheid Resistentie tegen kleinere stootbeschadigingen: Klasse 0</p>



Duschservice
Zum Hohlen Morgen 22
59939 Olsberg
Deutschland / Germany / Allemagne / Duitsland



Ersatzteilbestellung:
Fax 02962 / 972-4260



Allgemeine technische Probleme:
Telefon 02962 / 972-40



E-Mail:
ersatzteile@duschservice.de