

# CE EMC Test Report



(Declaration of Conformity)

For  
Electromagnetic compatibility  
Of

**Product :** Automatic induction night light

**Trade Mark :** AUVON

**Model Number :** A5121

## Prepared for

Shenzhen Yuwen E-Commerce Co., Ltd.  
703Room, 7th Floor, Zhonghuicai Building, Donghuan 1st Rd., Longhua Street, Longhua  
New District, Shenzhen 518109

## Prepared by

Shenzhen NTEK Testing Technology Co., Ltd.  
1/F, Building E, Fenda Science Park, Sanwei Community, Xixiang Street Bao'an  
District, Shenzhen 518126 P.R. China  
Tel.: +86-755-6115 6588 Fax.: +86-755-6115 6599  
Website: <http://www.ntek.org.cn>

TEST RESULT CERTIFICATION

Applicant's Name : Shenzhen Yuwen E-Commerce Co., Ltd.
Address : 703Room, 7th Floor, Zhonghuicai Building, Donghuan 1st Rd., Longhua Street, Longhua New District, Shenzhen 518109
Manufacturer's Name : Shenzhen Norton brilliant electronicTechnology Co., Ltd.
Address : 106Room 2 building Sanlian community 111 Road Longhua Street Longhua District, shenzhen

Product description

Product name : Automatic induction night light
Model and/or type reference : A5121

Standards : EN 55015:2013+A1:2015
EN 61547:2009

This report shall not be reproduced except in full, without the written approval of NTEK, this document may be altered or revised by NTEK, personal only, and shall be noted in the revision of the document.

Date of Test :
Date (s) of performance of tests : 26 Sep 2018~08 Oct. 2018
Date of Issue : 06 Jan. 2019
Test Result : Pass

Note: All test data of this report are based on the original test report S18092603001E, dated by 2018-09-26.

Testing Engineer : Korka Lin
(Korka Lin)

Technical Manager : Sky Zhang
(Sky Zhang)

Authorized Signatory : Sam Chen
(Sam Chen)



**Table of Contents**
**Page**

1 . TEST SUMMARY	5
1.1 TEST FACILITY	6
1.2 MEASUREMENT UNCERTAINTY	6
2 . GENERAL INFORMATION	8
2.1 GENERAL DESCRIPTION OF EUT	8
2.2 DESCRIPTION OF TEST MODES	9
2.3 DESCRIPTION OF TEST SETUP	10
2.4 DESCRIPTION TEST PERIPHERAL AND EUT PERIPHERAL	11
2.5 MEASUREMENT INSTRUMENTS LIST	12
3 . EMC EMISSION TEST	14
3.1 RADIATED EMISSION MEASUREMENT	14
3.1.1 LIMITS OF RADIATED EMISSION MEASUREMENT	14
3.1.2 TEST PROCEDURE	14
3.1.3 TEST SETUP	15
3.1.4 EUT OPERATING CONDITIONS	15
3.1.5 TEST RESULTS(30-300MHz)	16
3.1.6 TEST RESULTS(0.009-30MHz)	18
4 . EMC IMMUNITY TEST	21
4.1 STANDARD COMPLIANCE/SEVERITY LEVEL/CRITERIA	21
4.2 GENERAL PERFORMANCE CRITERIA	22
4.3 GENERAL PERFORMANCE CRITERIA TEST SETUP	22
4.4 ESD TESTING	23
4.4.1 TEST SPECIFICATION	23
4.4.2 TEST PROCEDURE	23
4.4.3 TEST SETUP	24
4.4.4 TEST RESULTS	25
4.5 RS TESTING	26
4.5.1 TEST SPECIFICATION	26
4.5.2 TEST PROCEDURE	26
4.5.3 TEST SETUP	27
4.5.4 TEST RESULTS	28
4.6 POWER FREQUENCY MAGNETIC FIELD TESTING	29
4.6.1 TEST SPECIFICATION	29
4.6.2 TEST PROCEDURE	29
4.6.3 TEST SETUP	30
4.6.4 TEST RESULTS	31

<b>Table of Contents</b>	<b>Page</b>
5 . EUT TEST PHOTO	32
ATTACHMENT PHOTOGRAPHS OF EUT	33

## 1. TEST SUMMARY

Test procedures according to the technical standards:

EMC Emission				
Standard	Test Item	Limit	Judgment	Remark
EN 55015:2013+A1:2015	Conducted Emission	-----	N/A	
	Radiated Emission	-----	PASS	
EMC Immunity				
Section	Test Item	Performance Criteria	Judgment	Remark
EN 61547:2009				
EN 61000-4-2	Electrostatic Discharge	B	PASS	
EN 61000-4-3	RF electromagnetic field	A	PASS	
EN 61000-4-4	Fast transients	B	N/A	
EN 61000-4-5	Surges	C	N/A	
EN 61000-4-6	Injected Current	A	N/A	
EN 61000-4-8	Power Frequency Magnetic Field	A	PASS	
EN 61000-4-11	Volt. Interruptions Volt. Dips	B / C	N/A	NOTE (1)

### NOTE:

- (1) Voltage Interruption: 100% reduction – Performance Criteria B  
Voltage dip: 30% reduction – Performance Criteria C
- (2) "N/A" denotes test is not applicable in this Test Report.
- (3) For client's request and manual description, the test will not be executed.

### 1.1 TEST FACILITY

Shenzhen NTEK Testing Technology Co., Ltd.

Add. : 1/F, Building E, Fenda Science Park, Sanwei Community, Xixiang Street Bao'an District, Shenzhen 518126 P.R. China

CNAS-Lab. : The Laboratory has been assessed and proved to be in compliance with CNAS-CL01:2006 (identical to ISO/IEC 17025:2005)  
The Certificate Registration Number is L5516

IC-Registration : The Certificate Registration Number is 9270A-1

FCC- Accredited : Test Firm Registration Number: 463705  
Designation Number: CN1184

A2LA-Lab. : The Certificate Registration Number is 4298.01  
This laboratory is accredited in accordance with the recognized International Standard ISO/IEC 17025:2005 General requirements for the competence of testing and calibration laboratories.  
This accreditation demonstrates technical competence for a defined scope and the operation of a laboratory quality management system (refer to joint ISO-ILAC-IAF Communiqué dated 8 January 2009).

### 1.2 MEASUREMENT UNCERTAINTY

The reported uncertainty of measurement  $y \pm U$ , where expanded uncertainty  $U$  is based on a standard uncertainty multiplied by a coverage factor of  $k=2$ , providing a level of confidence of approximately **95** %.

Test Item	Measurement Frequency Range	K	U(dB)
AC Mains Conducted Emission	0.009kHz ~ 0.15MHz	2	2.66
AC Mains Conducted Emission	0.15MHz ~ 30MHz	2	2.80
Telecom Conducted Emission (Cat 3)	0.15MHz ~ 30MHz	2	2.40
Telecom Conducted Emission (Cat 5)	0.15MHz ~ 30MHz	2	2.58
Radiated Emission	30MHz ~ 1000MHz	2	2.64
Radiated Emission	1000MHz ~ 6000MHz	2	2.40
Radiated Emission	6000MHz ~ 18000MHz	2	2.52
Power Clamp	30MHz ~ 300MHz	2	2.20



## 2. GENERAL INFORMATION

### 2.1 GENERAL DESCRIPTION OF EUT

Equipment	Automatic induction night light	
Model Name.	A5121	
Additional Model Number(s)	N/A	
Model Difference	N/A	
Product Description	The EUT is an Automatic induction night light.	
	Operating frequency:	N/A
	Connecting I/O port:	N/A
	Based on the application, features, or specification exhibited in User's Manual, the EUT is considered as an LED Lighting Device. More details of EUT technical specification, please refer to the User's Manual.	
Power Source	DC Voltage	
Power Rating	DC 5V, 1A powered by Micro USB port or DC 3.7V, 300mAh, 1.11Wh	



## 2.2 DESCRIPTION OF TEST MODES

To investigate the maximum EMI emission characteristics generates from EUT, the test system was pre-scanning tested base on the consideration of following EUT operation mode or test configuration mode which possible have effect on EMI emission level. Each of these EUT operation mode(s) or test configuration mode(s) mentioned above was evaluated respectively.

All test modes in the table below are tested, the worst case is listed on this report.

Pretest Mode	Description
Mode 1	Charging + ON(L / H)
Mode 2	Charging + Auto(L / H)

For Radiated Test	
Final Test Mode	Description
Mode 1	Charging + ON(L / H)
Mode 2	Charging + Auto(L / H)

For EMS Test	
Final Test Mode	Description
Mode 1	Charging + ON(L / H)
Mode 2	Charging + Auto(L / H)

### 2.3 DESCRIPTION OF TEST SETUP

Mode RE : Charging + ON(L / H)

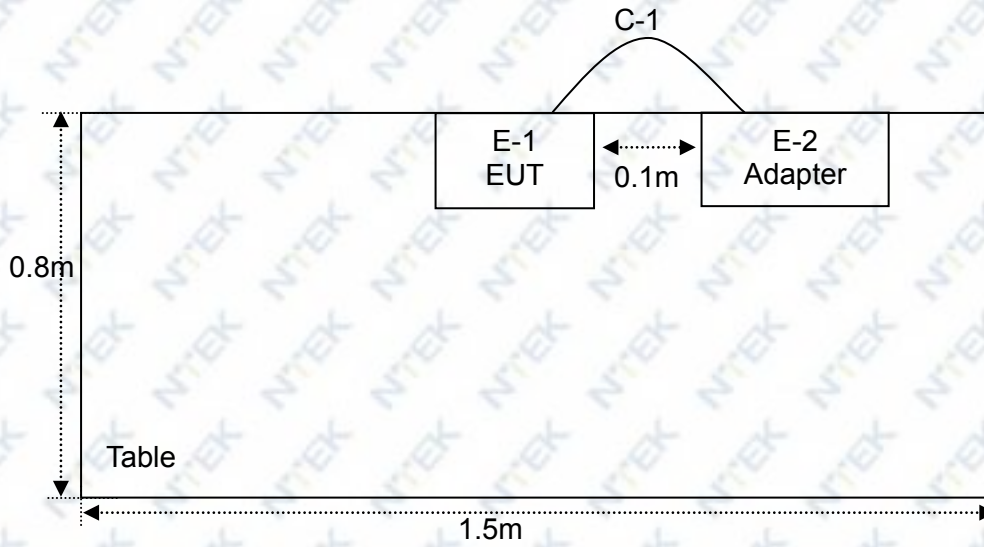

## 2.4 DESCRIPTION TEST PERIPHERAL AND EUT PERIPHERAL

The EUT has been tested as an independent unit together with other necessary accessories or support units. The following support units or accessories were used to form a representative test configuration during the tests.

Item	Equipment	Brand	Model/Type No.	Series No.	Note
E-1	Automatic induction night light	AUVON	A5121	N/A	EUT
E-2	Adapter	N/A	N/A	N/A	

Item	Shielded Type	Ferrite Core	Length	Note
C-1	NO	NO	30cm	

**Note:**

- (1) The support equipment was authorized by Declaration of Confirmation.
- (2) For detachable type I/O cable should be specified the length in cm in 『Length』 column.
- (3) “YES” means “shielded” “with core”; “NO” means “unshielded” “without core”.

## 2.5 MEASUREMENT INSTRUMENTS LIST

### 2.5.1 RADIATED TEST SITE

Item	Kind of Equipment	Manufacturer	Type No.	Serial No.	Last calibration	Calibrated until	Calibration period
1	Antenna Mast	SKET	N/A	N/A	N/A	N/A	N/A
2	Antenna Mast	EM	SC100	N/A	Apr. 26, 2017	Apr. 25, 2020	3 years
3	50Ω Switch	Anritsu	MP59B	6200983705	May 19, 2018	May 18, 2020	2 years
4	Test Cable	N/A	R-01	N/A	Aug. 08, 2016	Aug. 07, 2019	3 years
5	Pre-Amplifier	EMC	EMC051835S E	980246	Aug. 05, 2018	Aug. 04, 2019	1 year
6	Test Cable	N/A	R-03	N/A	Jun. 26, 2016	Jun. 25, 2019	3 years
7	EMI Test Receiver	R&S	ESCI	101160	May 19, 2018	May 18, 2019	1 year
8	Bilog Antenna	TESEQ	CBL6111D	31216	Apr. 08, 2018	Apr. 07, 2019	1 year
9	Broadband Horn Antenna	EM	EM-AH-10180	2011071402	Apr. 08, 2018	Apr. 07, 2019	1 year
10	Spectrum Analyzer	Agilent	E4440A	MY41000130	Mar. 28, 2018	Mar. 28, 2019	1 year
11	Triple Loop Antenna	EVERFINE	LLA-2	11020003	Aug. 05, 2018	Aug. 04, 2019	1 year
12	50Ω Switch	Anritsu	MP59B	6200983704	May 19, 2018	May 18, 2020	2 years
13	Absorbing Clamp	R&S	MDS-21	100423	Oct. 30, 2017	Oct. 29, 2018	1 year

### 2.5.2 ESD

Item	Kind of Equipment	Manufacturer	Type No.	Serial No.	Last calibration	Calibrated until	Calibration period
1	ESD TEST GENERATOR	Lioncel	ESD-203B	ESD203B015 0402	Oct. 30, 2017	Oct. 29, 2018	1 year

### 2.5.3 RS

Item	Kind of Equipment	Manufacturer	Type No.	Serial No.	Last calibration	Calibrated until	Calibration period
1	RF Test System Controller	AR	SC1000	0350156	Jan. 12, 2018	Jan. 11, 2021	3 years
2	3M Semi Anechoic Chamber	N/A	8*4*4	N/A	Jul. 10, 2017	Jul. 12, 2020	3 years
3	Power Amplifier	rflight	NTWPA-0081 0200	17063153	Aug. 05, 2018	Aug. 04, 2019	1 year
4	PSG Analog Signal Generator	Agilent	E8257D	MY51110112	Aug. 05, 2018	Aug. 04, 2019	1 year
5	Power Meter	Agilent	E4419B	MY45102538	Aug. 05, 2018	Aug. 04, 2019	1 year
6	Power Sensor	Agilent	E9301A	MY41495644	Aug. 05, 2018	Aug. 04, 2019	1 year
7	Power Sensor	Agilent	E9301A	US39212148	Aug. 05, 2018	Aug. 04, 2019	1 year
8	Broadband Amplifier	AR	60S1G6	0350414	Jan. 12, 2018	Jan. 11, 2019	1 year
9	Bilog Antenna	ETS	3142E	00214344	Dec. 06, 2017	Dec. 06, 2018	1 year

## 2.5.4 MF

Item	Kind of Equipment	Manufacturer	Type No.	Serial No.	Last calibration	Calibrated until	Calibration period
1	Generator	EVERFINE	EMS61000-8K	1007001	May 19, 2018	May 18, 2019	1 year

### 3. EMC EMISSION TEST

#### 3.1 RADIATED EMISSION MEASUREMENT

##### 3.1.1 LIMITS OF RADIATED EMISSION MEASUREMENT (Below 1000MHz)

FREQUENCY (MHz)	<input checked="" type="checkbox"/> 2m	<input type="checkbox"/> 3m	<input type="checkbox"/> 4m
	dB(μA)		
9kHz~ 70kHz	88	81	75
70kHz ~ 150kHz	88 to 58	81 to 51	75 to 45
150kHz ~ 3MHz	58 to 22	51 to 15	45 to 9
3MHz ~ 30MHz	22	15 to 16	9 to 12

FREQUENCY (MHz)	<input type="checkbox"/> At 10m	<input checked="" type="checkbox"/> At 3m
	dBμV/m	
30 – 230	30	40
230 – 300	37	47

Notes:

- (1) The limit for radiated test was performed according to as following: CISPR 15.
- (2) The tighter limit applies at the band edges.
- (3) Emission level (dBμV/m)=20log Emission level (uV/m).

##### 3.1.2 TEST PROCEDURE

- a. The measuring distance of at 3m shall be used for measurements at frequency up to 1GHz.
- b. The EUT was placed on the top of a rotating table 0.8 meters above the ground at a 3 meter open area test site. The table was rotated 360 degrees to determine the position of the highest radiation.
- c. The height of the equipment or of the substitution antenna shall be 0.8 m; the height of the test antenna shall vary between 1 m to 4 m. Both horizontal and vertical polarizations of the antenna are set to make the measurement.
- d. The initial step in collecting conducted emission data is a spectrum analyzer peak detector mode pre-scanning the measurement frequency range. Significant peaks are then marked and then Quasi Peak detector mode re-measured, above 1G Average detector mode will be instead.
- e. If the Peak Mode measured value compliance with and lower than Quasi Peak Mode Limit, the EUT shall be deemed to meet QP(AV) Limits and then no additional QP Mode measurement performed.
- f. For the actual test configuration, please refer to the related Item –EUT Test Photos.

3.1.3 TEST SETUP

(A) Radiated Emission Test Set-Up Frequency Below 30 MHz

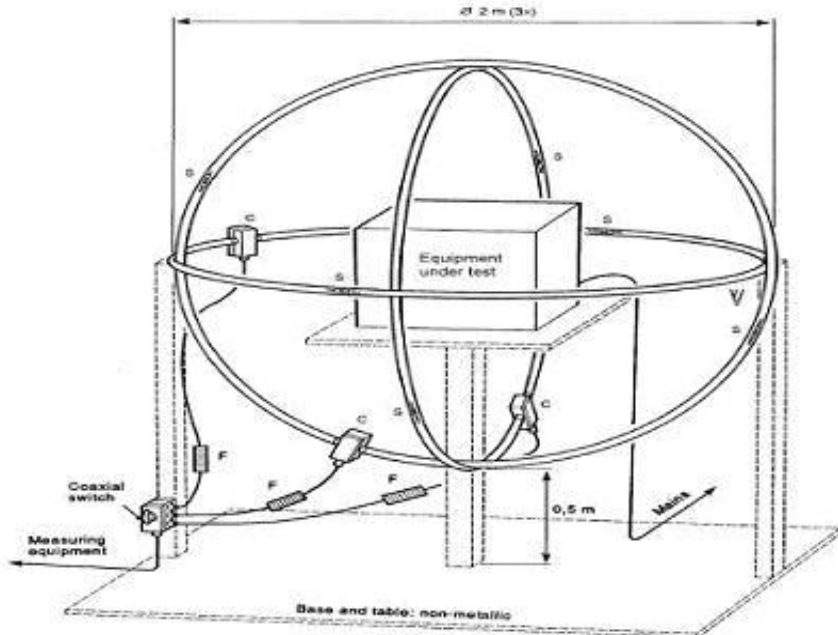

(B) Radiated Emission Test Set-Up Frequency Above 30 MHz

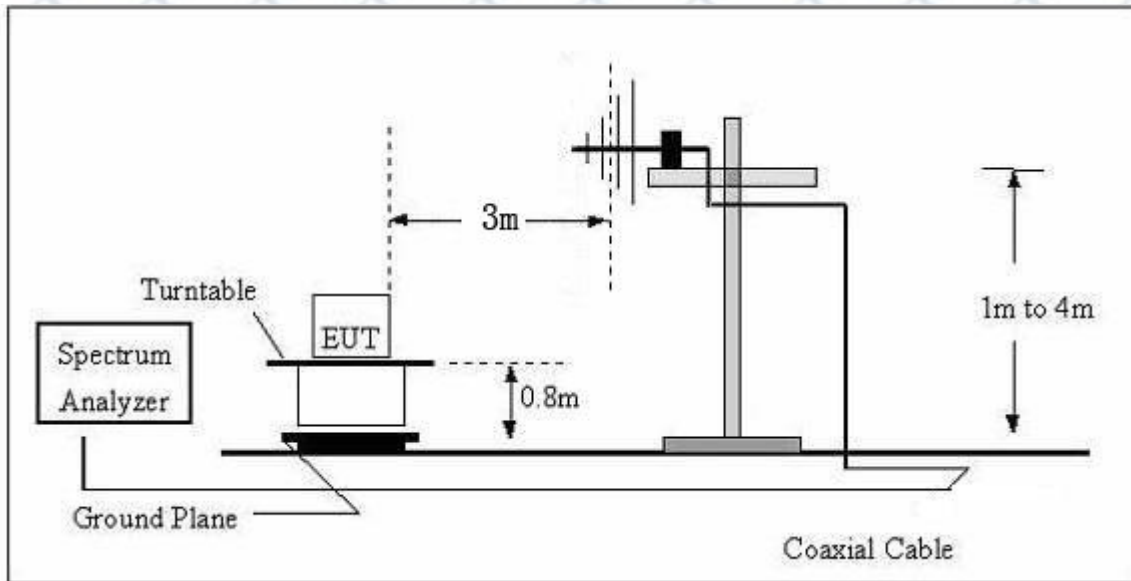

3.1.4 EUT OPERATING CONDITIONS

The EUT tested system was configured as the statements of 2.3 Unless otherwise a special operating condition is specified in the follows during the testing.

3.1.5 TEST RESULTS(30-300MHz)

EUT:	Automatic induction night light	Model Name:	A5121
Temperature:	20℃	Relative Humidity:	67%
Pressure:	1010hPa	Test Date :	2018-09-27
Test Mode:	Charging + ON(H)	Polarization :	Horizontal
Test Power:	AC 230V/50Hz		

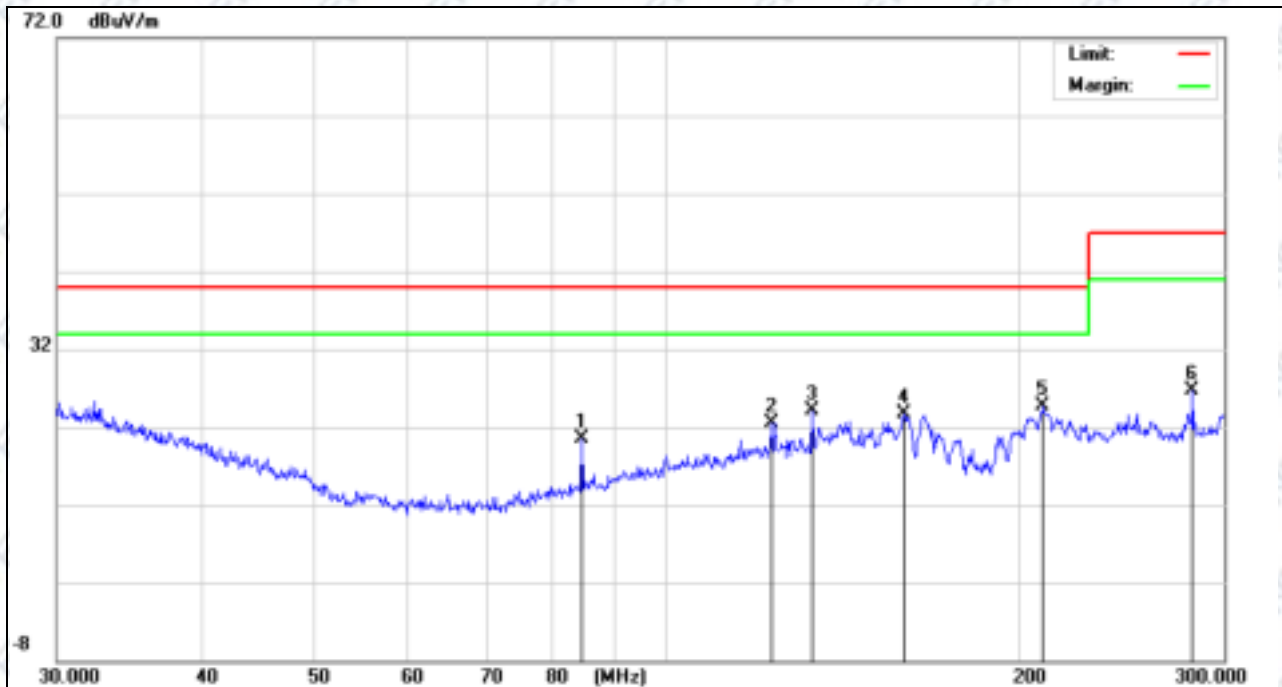

No.	Mk.	Freq.	Reading Level	Correct Factor	Measurement	Limit	Over	Antenna Height	Table Degree	
		MHz	dBuV	dB	dBuV/m	dBuV/m	dB	cm	degree	Comment
1		84.5515	11.00	9.53	20.53	40.00	-19.47	QP		
2		123.0611	9.34	13.26	22.60	40.00	-17.40	QP		
3		133.0826	10.71	13.41	24.12	40.00	-15.88	QP		
4		159.6324	12.03	11.64	23.67	40.00	-16.33	QP		
5	*	209.4696	13.65	10.97	24.62	40.00	-15.38	QP		
6		281.9169	9.99	16.66	26.65	47.00	-20.35	QP		

Remark:  
Factor = Antenna Factor + Cable Loss - Amplifier.



EUT:	Automatic induction night light	Model Name:	A5121
Temperature:	20°C	Relative Humidity:	67%
Pressure:	1010hPa	Test Date :	2018-09-27
Test Mode:	Charging + ON(H)	Polarization :	Vertical
Test Power:	AC 230V/50Hz		



No.	Mk.	Freq. MHz	Reading Level dBuV	Correct Factor dB	Measure- ment dBuV/m	Limit dBuV/m	Over dB	Detector	Antenna Height cm	Table Degree degree	Comment
1	*	33.5058	12.08	17.38	29.46	40.00	-10.54	QP			
2		63.1133	15.56	6.47	22.03	40.00	-17.97	QP			
3		67.9393	15.57	6.48	22.05	40.00	-17.95	QP			
4		127.3859	13.11	13.39	26.50	40.00	-13.50	QP			
5		155.6399	15.39	12.39	27.78	40.00	-12.22	QP			
6		207.5491	13.02	10.80	23.82	40.00	-16.18	QP			

Remark:  
Factor = Antenna Factor + Cable Loss - Amplifier.

3.1.6 TEST RESULTS(0.009-30MHz)

EUT:	Automatic induction night light	Model Name:	A5121
Temperature:	20℃	Relative Humidity:	57%
Pressure:	1010hPa	Test Date :	2018-09-28
Test Mode:	Charging + ON(H)	Polarization :	X
Test Power:	AC 230V/50Hz		

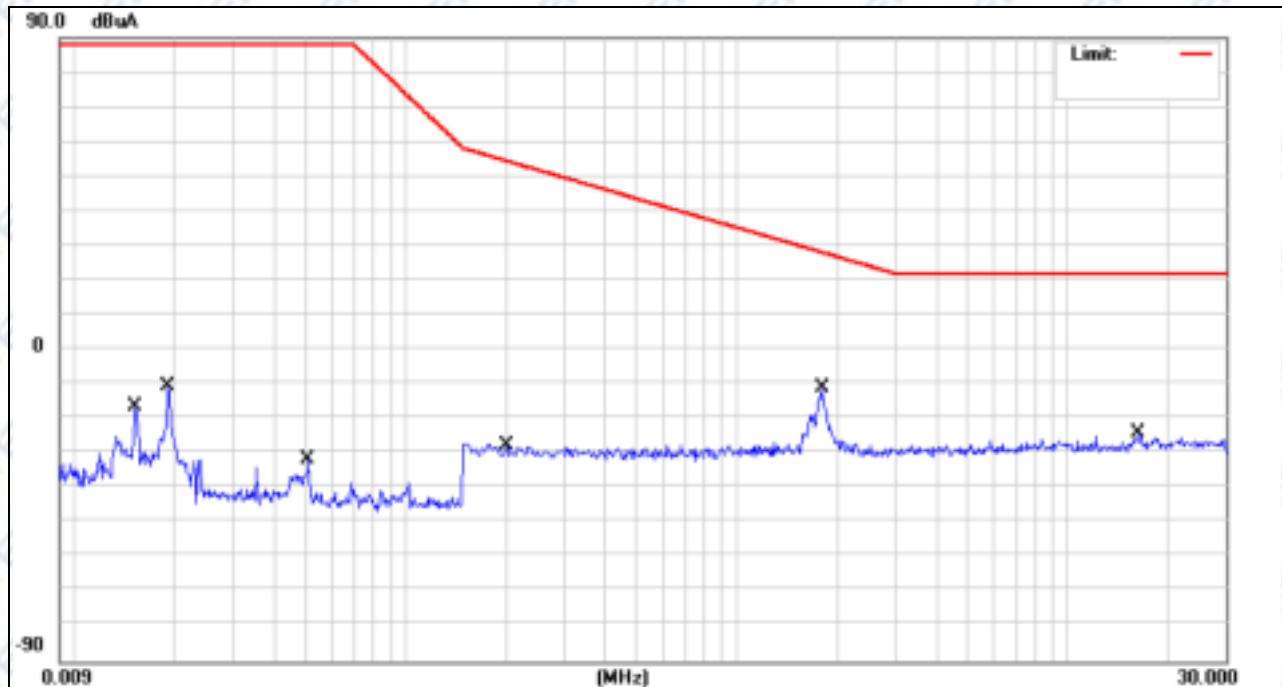

No.	Mk.	Freq.	Reading Level	Correct Factor	Measurement	Limit	Over	Detector	Comment
		MHz	dBuA	dB	dBuA	dBuA	dB		
1		0.0153	-16.65	0.01	-16.64	88.00	-104.64	QP	
2		0.0192	-10.78	0.02	-10.76	88.00	-98.76	QP	
3		0.0507	-31.64	0.02	-31.62	88.00	-119.62	QP	
4		0.2020	-27.86	0.03	-27.83	54.42	-82.25	QP	
5	*	1.8180	-11.23	0.11	-11.12	28.02	-39.14	QP	
6		16.3500	-24.49	0.41	-24.08	22.00	-46.08	QP	

Remark:  
Factor = Antenna Factor + Cable Loss.

EUT:	Automatic induction night light	Model Name:	A5121
Temperature:	20°C	Relative Humidity:	57%
Pressure:	1010hPa	Test Date :	2018-09-28
Test Mode:	Charging + ON(H)	Polarization :	Y
Test Power:	AC 230V/50Hz		

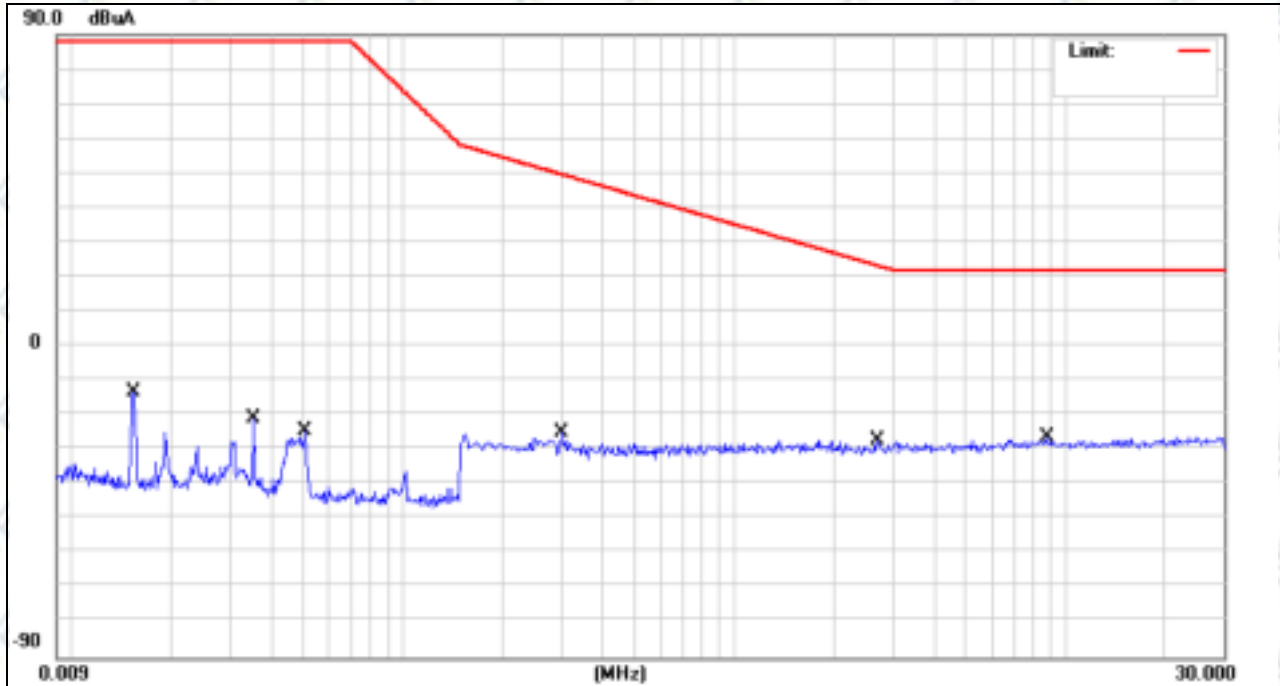

No.	Mk.	Freq. MHz	Reading Level dBuA	Correct Factor dB	Measure- ment dBuA	Limit dBuA	Over dB	Detector	Comment
1		0.0154	-13.40	0.01	-13.39	88.00	-101.39	QP	
2		0.0355	-20.77	0.02	-20.75	88.00	-108.75	QP	
3		0.0506	-24.60	0.02	-24.58	88.00	-112.58	QP	
4		0.3020	-25.24	0.04	-25.20	49.58	-74.78	QP	
5		2.7020	-27.38	0.15	-27.23	23.26	-50.49	QP	
6	*	8.7620	-26.79	0.29	-26.50	22.00	-48.50	QP	

Remark:  
Factor = Antenna Factor + Cable Loss.

EUT:	Automatic induction night light	Model Name:	A5121
Temperature:	20°C	Relative Humidity:	57%
Pressure:	1010hPa	Test Date :	2018-09-28
Test Mode:	Charging + ON(H)	Polarization :	Z
Test Power:	AC 230V/50Hz		

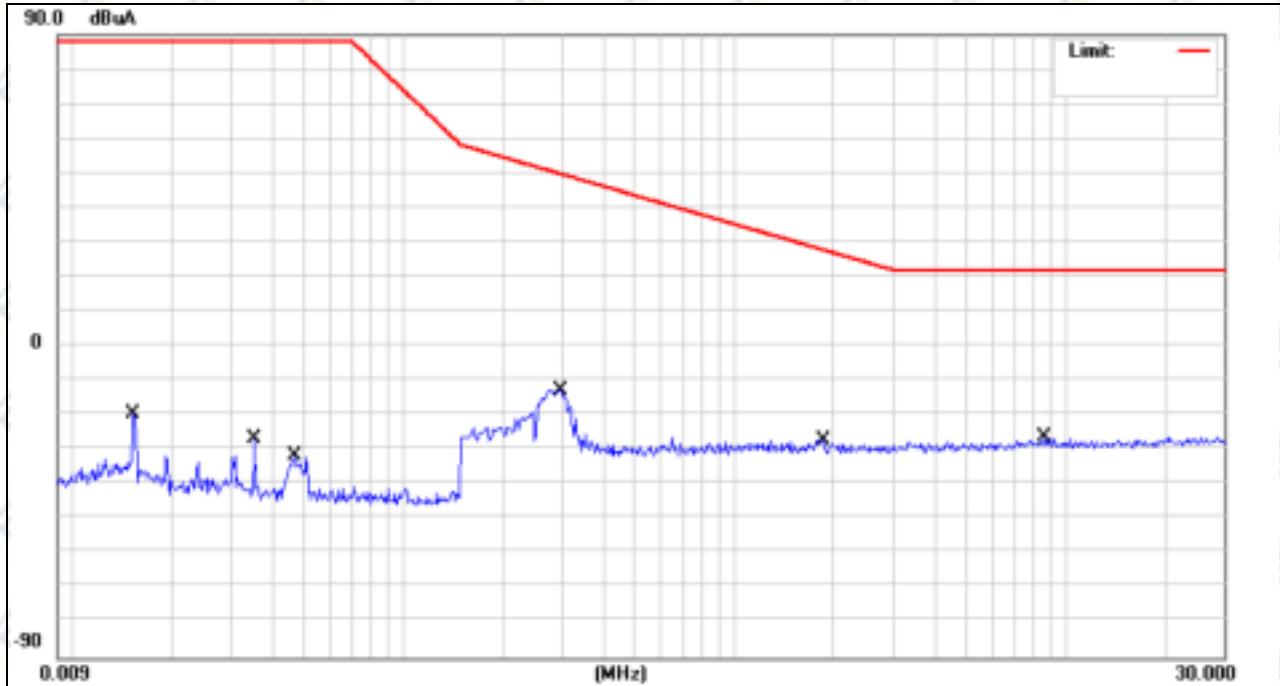

No.	Mk.	Freq. MHz	Reading Level dBuA	Correct Factor dB	Measurement dBuA	Limit dBuA	Over dB	Detector	Comment
1		0.0153	-19.62	0.01	-19.61	88.00	-107.61	QP	
2		0.0355	-26.80	0.02	-26.78	88.00	-114.78	QP	
3		0.0468	-31.71	0.02	-31.69	88.00	-119.69	QP	
4		0.2980	-12.71	0.04	-12.67	49.74	-62.41	QP	
5		1.8700	-27.25	0.11	-27.14	27.68	-54.82	QP	
6	*	8.6300	-26.74	0.28	-26.46	22.00	-48.46	QP	

Remark:  
Factor = Antenna Factor + Cable Loss.

#### 4. EMC IMMUNITY TEST

##### 4.1 STANDARD COMPLIANCE/SEVERITY LEVEL/CRITERIA

Tests Standard No.	TEST SPECIFICATION Level	Test Mode Test Ports	Perform. Criteria
1. ESD IEC/EN 61000-4-2	8kV air discharge 4kV contact discharge	Direct Mode	B
	4kV HCP discharge 4kV VCP discharge	Indirect Mode	B
2. RS IEC/EN 61000-4-3	80 MHz to 1000 MHz 1000Hz, 80%, AM modulated	Enclosure	A
3. Power Frequency Magnetic Field IEC/EN 61000-4-8	50 Hz	Enclosure	A

**4.2 GENERAL PERFORMANCE CRITERIA**

According to **EN 61547** standard, the general performance criteria as following:

<p><b>Criterion A</b></p>	<p>The equipment shall continue to operate as intended without operator intervention. No degradation of performance or loss of function is allowed below a performance level specified by the manufacturer when the equipment is used as intended.</p> <p>The performance level may be replaced by a permissible loss of performance. If the minimum performance level or the permissible performance loss is not specified by the manufacturer, then either of these may be derived from the product description and documentation, and by what the user may reasonably expect from the equipment if used as intended.</p>
<p><b>Criterion B</b></p>	<p>After the test, the equipment shall continue to operate as intended without operator intervention. No degradation of performance or loss of function is allowed, after the application of the phenomena below a performance level specified by the manufacturer, when the equipment is used as intended.</p> <p>The performance level may be replaced by a permissible loss of performance. During the test, degradation of performance is allowed. However, no change of operating state or stored data is allowed to persist after the test.</p>
<p><b>Criterion C</b></p>	<p>Loss of function is allowed, provided the function is self-recoverable, or can be restored by the operation of the controls by the user in accordance with the manufacturer's instructions. Functions, and/or information stored in non-volatile memory, or protected by a battery backup, shall not be lost.</p>

**4.3 GENERAL PERFORMANCE CRITERIA TEST SETUP**

The EUT tested system was configured as the statements of 2.3 Unless otherwise a special operating condition is specified in the follows during the testing.

#### 4.4 ESD TESTING

##### 4.4.1 TEST SPECIFICATION

Basic Standard:	IEC/EN 61000-4-2
Discharge Impedance:	330ohm / 150pF
Required Performance:	B
Discharge Voltage:	Air Discharge:2kV/4kV/8kV (Direct) Contact Discharge:2kV/4kV (Direct/Indirect)
Polarity:	Positive & Negative
Number of Discharge:	Air Discharge: min. 20 times at each test point Contact Discharge: min. 20 times at each test point
Discharge Mode:	Single Discharge
Discharge Period:	1 second minimum

##### 4.4.2 TEST PROCEDURE

The test generator necessary to perform direct and indirect application of discharges to the EUT in the following manner:

a. Indirect application of the discharge:

Vertical Coupling Plane (VCP):

At least 10 single discharges (in the most sensitive polarity) shall be applied to the centre of one vertical edge of the coupling plane. The coupling plane, of dimensions 0,5 m × 0,5 m, is placed parallel to, and positioned at a distance of 0,1 m from, the EUT.

Discharges shall be applied to the coupling plane, with sufficient different positions such that the four faces of the EUT are completely illuminated. One VCP position is considered to illuminate 0,5 m × 0,5 m area of the EUT surface.

Horizontal Coupling Plane (HCP):

Discharge to the HCP shall be made horizontally to the edge of the HCP.

At least 10 single discharges (in the most sensitive polarity) shall be applied at the front edge of each HCP opposite the centre point of each unit (if applicable) of the EUT and 0.1m from the front of the EUT. The long axis of the discharge electrode shall be in the plane of the HCP and perpendicular to its front edge during the discharge.

The discharge electrode shall be in contact with the edge of the HCP before the discharge switch is operated

b. Direct application of discharges to the EUT

The test shall be performed with single discharges. On each pre-selected point at least 10 single discharges (in the most sensitive polarity) shall be applied.

For the time interval between successive single discharges an initial value of 1 s is recommended. Longer intervals may be necessary to determine whether a system failure has occurred.

4.4.3 TEST SETUP

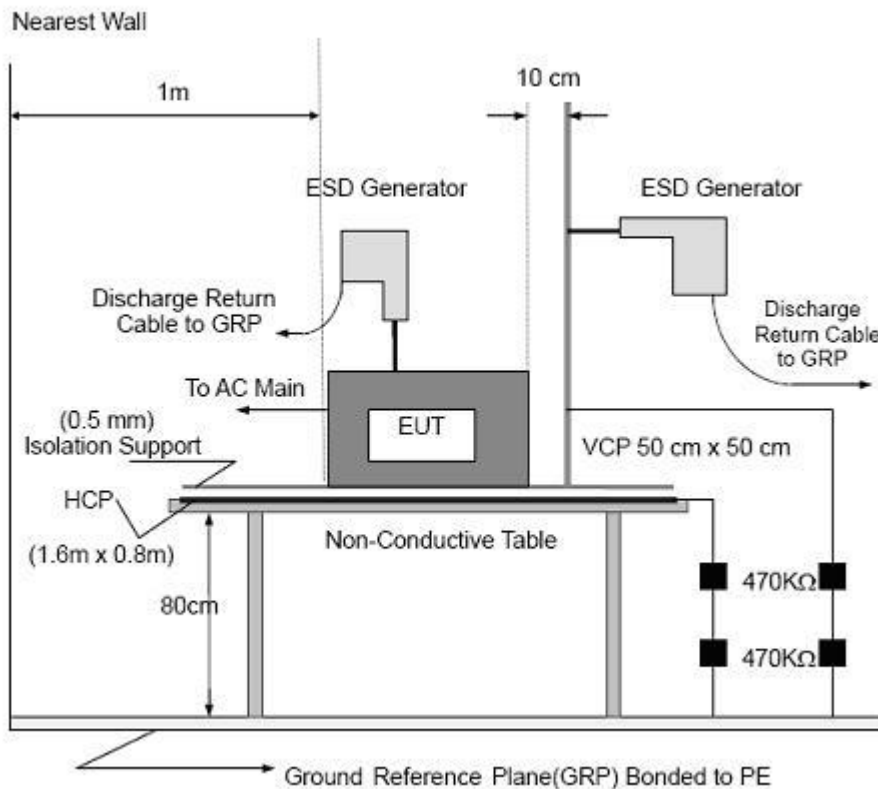

Note:

TABLE-TOP EQUIPMENT

The configuration consisted of a wooden table 0.8 meters high standing on the Ground Reference Plane. The GRP consisted of a sheet of aluminum at least 0.25mm thick, and 2.5 meters square connected to the protective grounding system. A Horizontal Coupling Plane (1.6m x 0.8m) was placed on the table and attached to the GRP by means of a cable with 940k total impedance. The equipment under test, was installed in a representative system as described in section 7 of IEC /EN 61000-4-2, and its cables were placed on the HCP and isolated by an insulating support of 0.5mm thickness. A distance of 1-meter minimum was provided between the EUT and the walls of the laboratory and any other metallic structure.

FLOOR-STANDING EQUIPMENT

The equipment under test was installed in a representative system as described in section 7 of IEC/EN 61000-4-2, and its cables were isolated from the Ground Reference Plane by an insulating support of 0.1-meter thickness. The GRP consisted of a sheet of aluminum that is at least 0.25mm thick, and 2.5meters square connected to the protective grounding system and extended at least 0.5 meters from the EUT on all sides.



## 4.4.4 TEST RESULTS

EUT:	Automatic induction night light	Model Name:	A5121
Temperature:	23°C	Relative Humidity:	51%
Pressure:	1010hPa	Test Date :	2018-09-28
Test Mode:	Charging + ON(L / H) / Charging + Auto(L / H)		
Test Power:	AC 230V/50Hz		

Mode	Contact Discharge (Indirect)						Criterion	Result		
	Test level(kV)	Test Point	2		4				6	
			+	-	+	-			+	-
HCP	Front	P	P	P	P			<b>B</b>	<b>Complies</b>	
	Rear	P	P	P	P					
	Left	P	P	P	P					
	Right	P	P	P	P					
VCP	Front	P	P	P	P					
	Rear	P	P	P	P					
	Left	P	P	P	P					
	Right	P	P	P	P					

Mode	Air Discharge								Contact Discharge								Criterion	Result	
	2		4		8		15		2		4		6		8				
	+	-	+	-	+	-	+	-	+	-	+	-	+	-	+	-			
Gap	P	P	P	P	P	P												<b>B</b>	<b>Complies</b>
Button	P	P	P	P	P	P													
LED	P	P	P	P	P	P													
Micro USB port									P	P	P	P							
Metal									P	P	P	P							

Note:

- 1) +/- denotes the Positive/Negative polarity of the output voltage.
- 2) Test location(s) in which discharge (Air and contact discharge) to be applied illustrated by photos shown in next page(s)
- 3) In the table: „P“ represents „PASS“; „F“ represents „FAIL“.
- 4) Criteria A: Normal performance within limits specified by the manufacturer, requestor or purchaser.
- 5) Criteria B: Temporary loss of function or degradation of performance which ceases after the disturbance ceases, and from which the EUT recovers its normal performance, without operator intervention.
- 6) Criteria C: Temporary loss of function or degradation of performance, the correction of which requires operator intervention.
- 7) Criteria D: Loss of function or degradation of performance which is not recoverable, owing to damage to hardware or software, or loss of data.

## 4.5 RS TESTING

### 4.5.1 TEST SPECIFICATION

Basic Standard:	IEC/EN 61000-4-3
Required Performance:	A
Frequency Range:	80 MHz - 1000 MHz
Field Strength:	3 V/m
Modulation:	1kHz Sine Wave, 80%, AM Modulation
Frequency Step:	1 % of fundamental
Polarity of Antenna:	Horizontal and Vertical
Test Distance:	3 m
Antenna Height:	1.5 m
Dwell Time:	3 seconds

### 4.5.2 TEST PROCEDURE

The EUT and support equipment, which are placed on a table that is 0.8 meter above ground and the testing was performed in a fully-anechoic chamber.

The testing distance from antenna to the EUT was 3 meters.

The other condition as following manner:

- a. The frequency range is swept from 80 MHz to 1000 MHz with the signal 80% amplitude modulated with a 1kHz sine wave. The rate of sweep did not exceed  $1.5 \times 10^{-3}$  decade/s. Where the frequency range is swept incrementally, the step size was 1% of fundamental.
- b. Sweep Frequency 900 MHz, with the Duty Cycle: 1/8 and Modulation: Pulse 217 Hz (if applicable)
- c. The dwell time at each frequency shall be not less than the time necessary for the EUT to be able to respond.
- d. The test was performed with the EUT exposed to both vertically and horizontally polarized fields on each of the four sides.

4.5.3 TEST SETUP

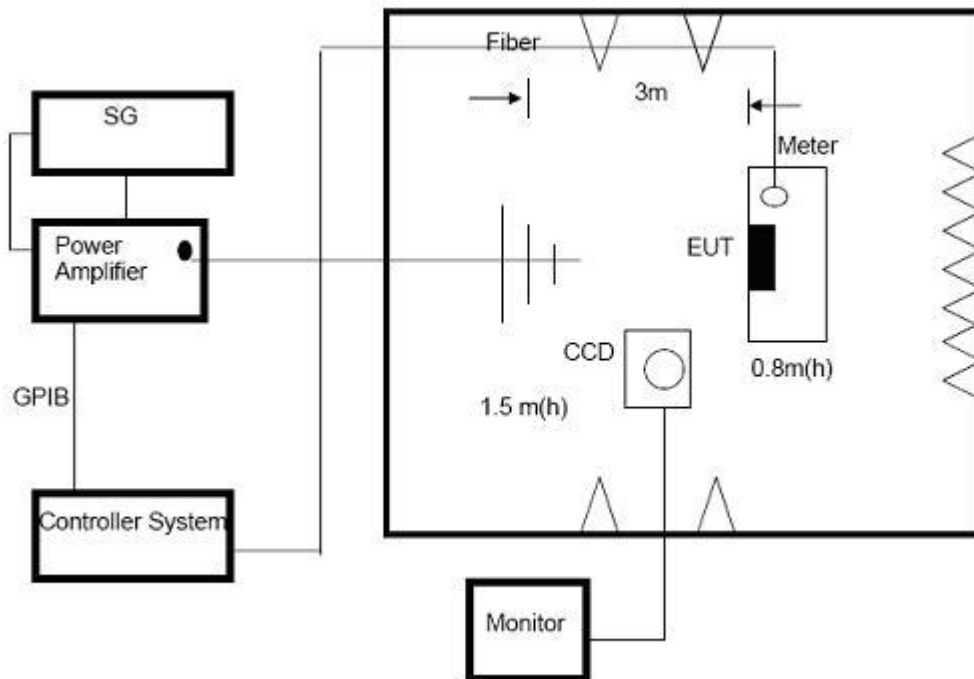

Note:

TABLE-TOP EQUIPMENT

The EUT installed in a representative system as described in section 7 of IEC/EN 61000-4-3 was placed on a non-conductive table 0.8 meters in height. The system under test was connected to the power and signal wire according to relevant installation instructions.

FLOOR-STANDING EQUIPMENT

The EUT installed in a representative system as described in section 7 of IEC/EN 61000-4-3 was placed on a non-conductive wood support 0.1 meters in height. The system under test was connected to the power and signal wire according to relevant installation instructions.

## 4.5.4 TEST RESULTS

EUT:	Automatic induction night light	Model Name:	A5121
Temperature:	24°C	Relative Humidity:	48%
Pressure:	1010hPa	Test Date :	2018-09-28
Test Mode:	Charging + ON(L / H) / Charging + Auto(L / H)		
Test Power:	AC 230V/50Hz		

Frequency Range (MHz)	RF Field Position	R.F. Field Strength	Azimuth	Perform. Criteria	Results	Judgment
80MHz - 1000MHz	H / V	3 V/m (r.m.s) AM Modulated 1000Hz, 80%	Front	<b>A</b>	<b>P</b>	<b>Complies</b>
			Rear			
			Left			
			Right			

## Note:

- 1) N/A - denotes test is not applicable in this test report.
- 2) In the table: „P“ represents „PASS“, „F“ represents „FAIL“.
- 3) Criteria A: There was no change operated with initial operating during the test.
- 4) Criteria B: The EUT function loss during the test, but self-recoverable after the test.
- 5) Criteria C: The system shut down during the test.

## 4.6 POWER FREQUENCY MAGNETIC FIELD TESTING

### 4.6.1 TEST SPECIFICATION

Basic Standard:	IEC/EN 61000-4-8
Required Performance:	A
Frequency Range:	50Hz
Field Strength:	3 A/m
Observation Time:	5 minutes
Inductance Coil:	Rectangular type, 1mx1m

### 4.6.2 TEST PROCEDURE

The EUT and support equipment, are placed on a table that is 0.8 meter above a metal ground plane measured 1m\*1m min. and 0.65mm thick min.

The other condition as following manner:

- a. The equipment cabinets shall be connected to the safety earth directly on the GRP via the earth terminal of the EUT.
- b. The cables supplied or recommended by the equipment manufacturer shall be used. 1 meter of all cables used shall be exposed to the magnetic field.

4.6.3 TEST SETUP

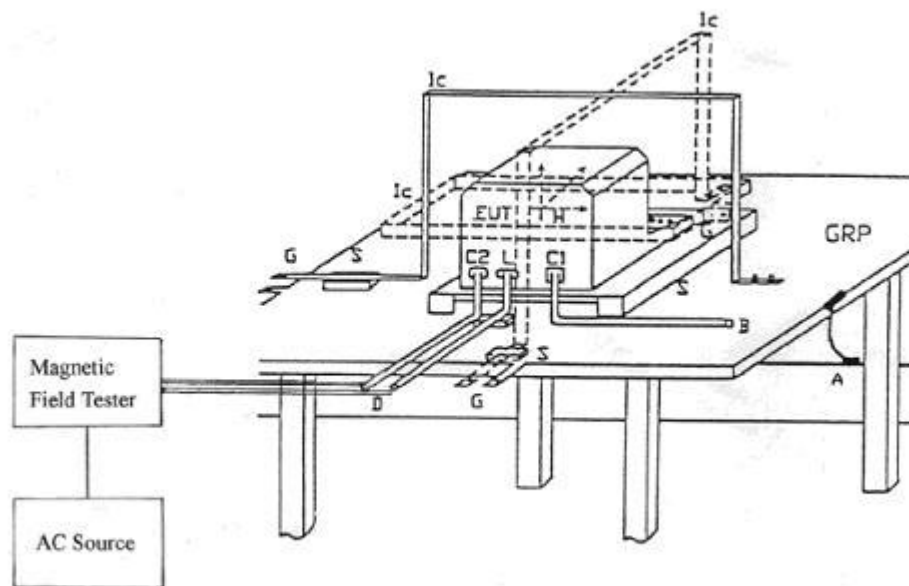

Note:

TABLE-TOP EQUIPMENT

The equipment shall be subjected to the test magnetic field by using the induction coil of standard dimension (1 m x 1 m). The induction coil shall then be rotated by 90 degrees in order to expose the EUT to the test field with different orientations.

FLOOR-STANDING EQUIPMENT

The equipment shall be subjected to the test magnetic field by using induction coils of suitable dimensions. The test shall be repeated by moving and shifting the induction coils, in order to test the whole volume of the EUT for each orthogonal direction. The test shall be repeated with the coil shifted to different positions along the side of the EUT, in steps corresponding to 50 % of the shortest side of the coil. The induction coil shall then be rotated by 90 degrees in order to expose the EUT to the test field with different orientations.

## 4.6.4 TEST RESULTS

EUT:	Automatic induction night light	Model Name:	A5121
Temperature:	23°C	Relative Humidity:	51%
Pressure:	1010hPa	Test Date :	2018-09-28
Test Mode:	Charging + ON(L / H) / Charging + Auto(L / H)		
Test Power:	AC 230V/50Hz		

Test Mode	Test Level	Antenna aspect	Duration (s)	Perform Criteria	Results	Judgment
Enclosure	3 A/m	X	300 s	A	P	Complies
Enclosure	3 A/m	Y	300 s	A	P	
Enclosure	3 A/m	Z	300 s	A	P	

## Note:

- 1) N/A - denotes test is not applicable in this test report
- 2) In the table: „P“ represents „PASS“, „F“ represents „FAIL“.
- 3) Criteria A: There was no change operated with initial operating during the test.
- 4) Criteria B: The EUT function loss during the test, but self-recoverable after the test.
- 5) Criteria C: The system shut down during the test.

5. EUT TEST PHOTO

Radiated Measurement Photos

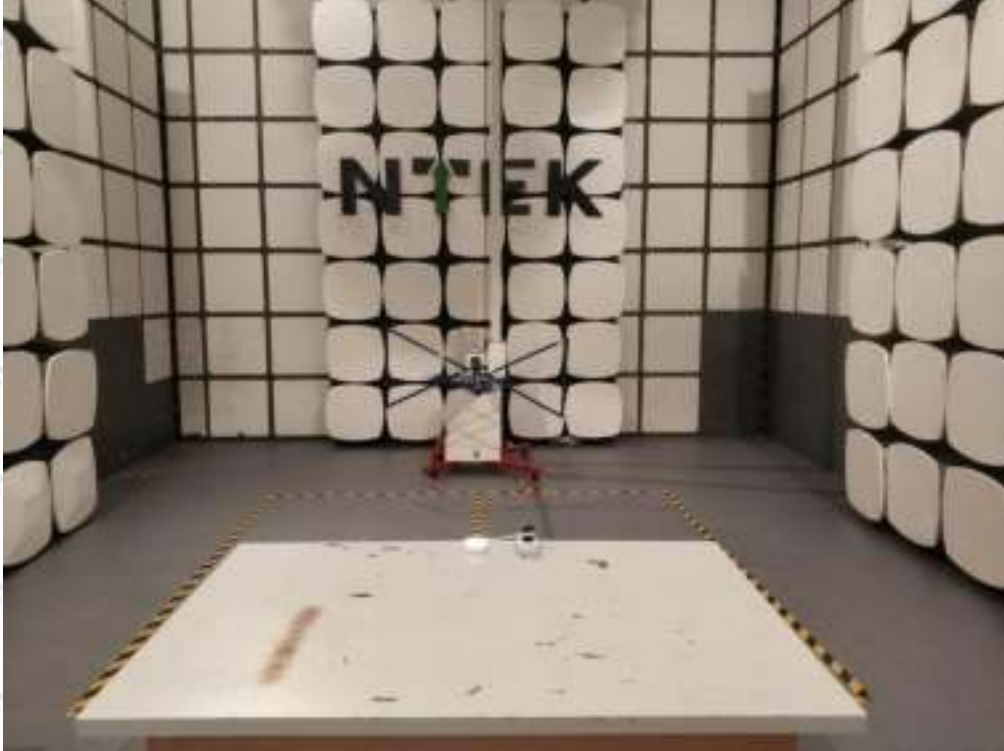



ATTACHMENT PHOTOGRAPHS OF EUT

Photo 1



Photo 2



Photo 3



Photo 4



Photo 5



Photo 6



Photo 7



Photo 8



Photo 9

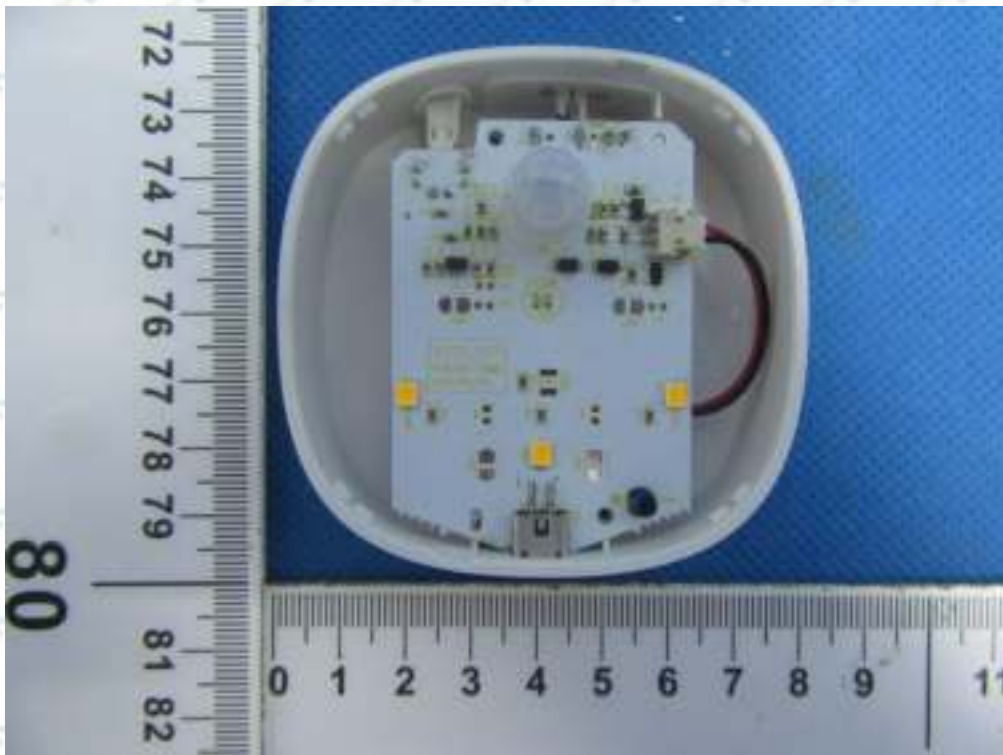

Photo 10

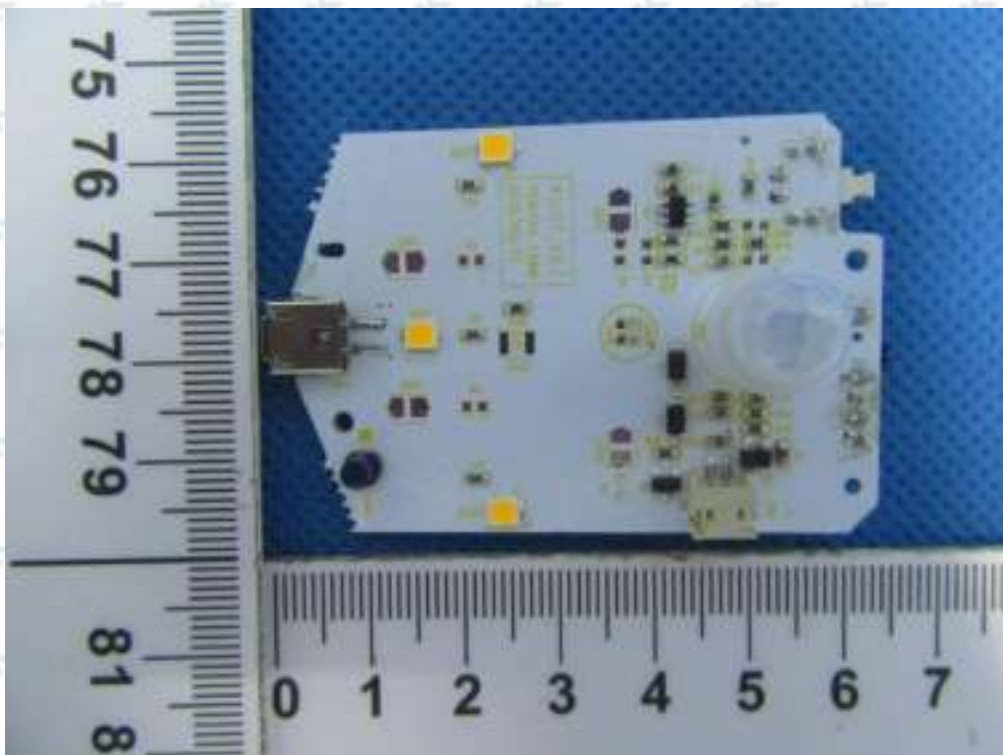

Photo 11

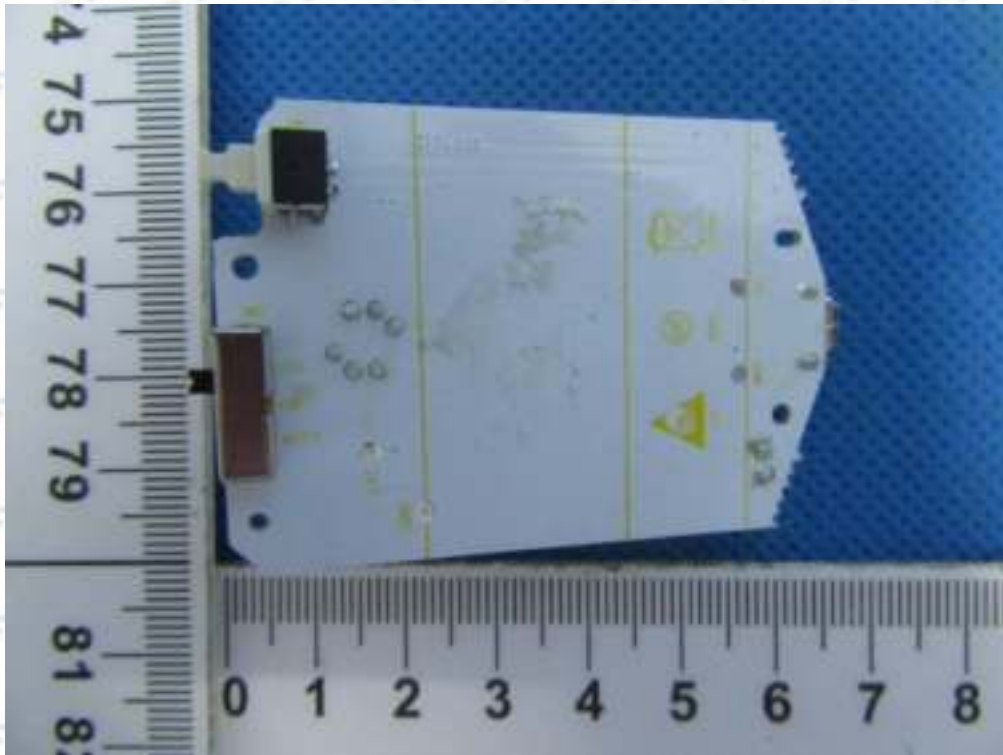

Photo 12

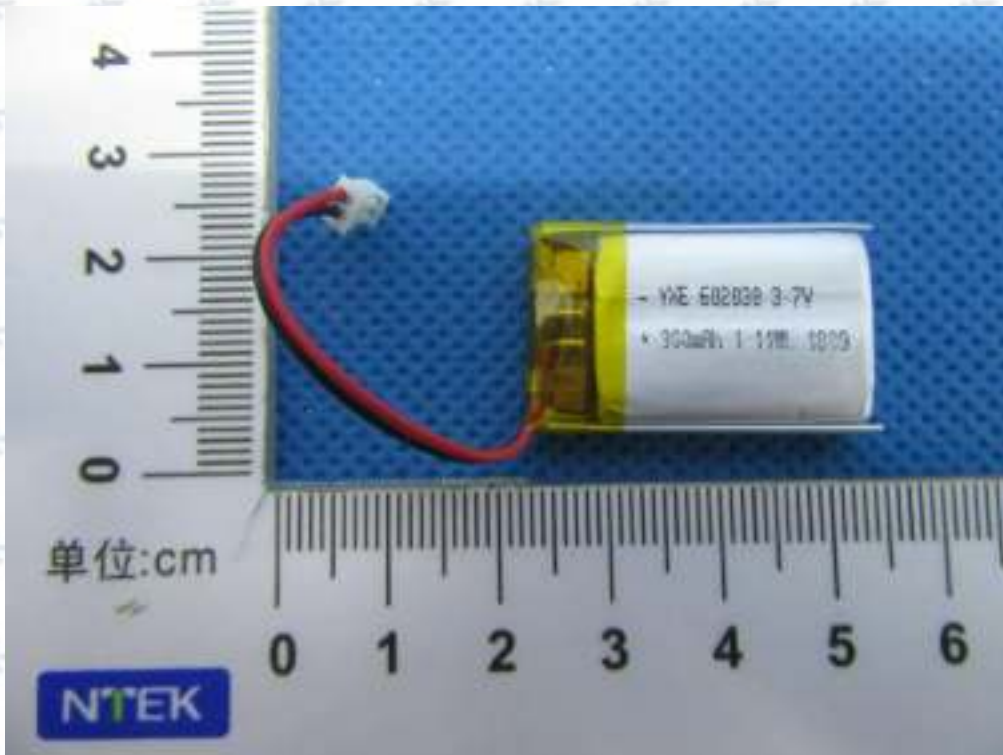

Photo 13



Photo 14



Photo 15



Photo 16





Photo 17



Photo 18

