



# SilverRX series

owners manual







# CONTENTS PAGE

Important Safety Instructions _____	2
Recycling _____	3
RoHS Declaration of Conformity _____	3
Introduction _____	4
Positioning _____	6
AV Positioning _____	6
2 Channel Positioning _____	9
Setting up the RX-FX _____	9
Fixing the RX-FX to a Wall _____	10
Plinth Fixing _____	10
Grilles _____	10
Spiked Foot Fixing _____	11
Port Bungs _____	12
Specifications _____	13
Guarantee and Service _____	14
Claims Under the Guarantee _____	14
Data Protection _____	15
Owner Information _____	15
EC Declaration of Conformity _____	16



## IMPORTANT SAFETY INSTRUCTIONS

- 1. Please read these instructions.**
- 2. Please keep these instructions.**
- 3. Heed all warnings.**
- 4. Follow all instructions.**
- 5. Do not use this apparatus with water.**
- 6. Clean only with a dry cloth.** Great care and attention has gone into the materials chosen to produce the Silver RX Series. A gentle wipe with a dry, clean cloth is all that is required to remove any dust. Treat them as you would a fine piece of furniture because that is how they have been designed. To clean the high gloss finishes use our “Lacquer Polish” that has been developed alongside Auto Glym. It can only be purchased from the shop on our web site.
- 7. Do not install near any heat source,** such as radiators, heat registers, stoves, or other apparatus (including amplifiers) that produce heat.
- 8. Only use attachments/ accessories specified by Monitor Audio.**
- 9. Use only with the cart,** stand, tripod, bracket, or table specified by monitor Audio or sold with the apparatus. When a cart is used, use caution when moving the cart/ apparatus combination to avoid injury from tip-over.



- 10. Refer all servicing to qualified service personnel.** Servicing is required when the apparatus has been damaged in any way, such as power supply cord or plug is damaged, liquid has been spilled or objects have fallen onto the apparatus, the apparatus has been exposed to rain or moisture, does not operate normally or has been dropped.
- 11. This apparatus shall not be exposed to dripping or splashing water** and that no object filled with liquids such as vases shall be placed on the apparatus.
- 12. This exclamation point within an equilateral triangle** is intended to alert the user to the presence of important maintenance (servicing) instructions in the literature accompanying the appliance.





## RE-CYCLING

Correct Disposal of Waste Electrical and Electronic Equipment (WEEE) by User in Private Households in the EU.

This symbol on the product or accessories indicates that they must not be disposed of with your household wastes throughout the EU. To prevent possible harm to the environment or human health from uncontrolled waste disposal, recycle it responsibly to promote the sustainable reuse of material resources. Instead it is your responsibility to dispose of your waste equipment by handing it over to a designated WEEE collection point for recycling. The separate collection and recycling of your waste equipment will help conserve natural resources and ensure that it is recycled in a manner that protects human health and the environment.



For more specific information about where you can take your equipment for recycling please contact your local city/council office, your local waste disposal service or the outlet where you purchased your Silver RX product.

## ROHS DECLARATION OF CONFORMITY

Directive 2002/95/EC of the European Parliament and of the Council on the reduction of the use of certain hazardous substances in electrical and electronic equipment, January 2003.



## Background

The RoHS directive restricts the use of Lead (Pb), Cadmium (Cd), Mercury (Hg), hexavalent Chromium (CrVI), polybrominated biphenyl (PBB) compounds, and polybrominated diphenyl ether (PBDE) compounds in electrical and electronic equipment sold in the European Union.





## INTRODUCTION

The new Silver RX Series builds on the huge success of the award winning Silver RS Series by incorporating advanced technologies, developed from the prestigious Platinum and Gold Signature Series. It's the blend of these advanced technologies that makes the new RX Series so unique, with performance to eclipse that of its predecessor.

Honed from the renowned C-CAM® material, the new RST® cone profile has been designed and refined using hi-tech computer simulation to reduce cone break up and provide purer, more natural mid-range clarity. The rigid, non magnetic cast polymer chassis incorporates venting to keep the driver cool as well as reduce internal pressure, resulting in the ability to play louder and cleaner.

A new C-CAM gold dome tweeter has been optimised to propel high frequency performance to beyond 35kHz, enabling the full potential of current and future wide-bandwidth High Definition audio and cinema formats.

HiVe®II port design has been introduced, providing clean powerful bass and superior transient response. Single bolt through driver technology has also been employed to enhance cabinet rigidity by providing additional bracing, whilst maintaining consistent tension for the driver. This in turn reduced excessive vibration from the driver and cabinet together, giving lower colouration across the entire frequency spectrum. Stylish magnetic grilles have no visible fixings and provide clean overall visuals, adding to the simplicity and refinement of the smooth overall appearance.

The Silver RX range has all the necessary ingredients to build the most demanding audio or multi-channel systems. From a two-channel audiophile set-up to serious theatre install, the Silver RX Series blends versatility, performance and style coupled with the ethos of Monitor Audio's long audiophile heritage.

### RX1

The diminutive RX1 is configured to offer an impressively natural, rhythmic sound in a beautifully compact and practical form. Standing at just 31cm tall, the RX1 will deliver faithful crystal-clear definition and power from just about anywhere. Perfect for music and film sound where space is at a premium, the RX1 provides elite Monitor Audio quality to refresh and enliven your system.

### RX2

The larger RX2 is designed as an audiophile compact 2-way speaker, having the efficiency and bandwidth of a much larger speaker, while being easier to position around the home. It offers extended high frequencies to resolve hidden detail, coupled with immense dynamic headroom and bass depth, so that all the delicacy and drama of your favourite and future music and film sound is revealed.





## RX6

The elegant floor-standing RX6 places the new wider-bandwidth RX tweeter in concert with freshly-designed 6" C-CAM bass and 6" C-CAM bass/mid drivers to form a balanced two-and-a-half way system. Separate chambers are utilised within the enclosure to provide differential tuning for the 6" drivers, producing higher efficiency and exceptional low frequency extension. For such a slim, easy-to-position speaker, the innovative RX6 is capable of an extraordinarily wide bandwidth, enhanced with a natural tonality that breathes life into every format – even HD audio. Base plinths are supplied for added stability.

## RX8

A feat of ergonomic brilliance by our design team has engineered the greater poise and power of a large three-way loudspeaker into the svelte RX8. Its ultra-slim front profile hides a slightly deeper cabinet, which provides the volume needed for seismic levels of bass from dual 6" bass drivers. A single 6" bass/mid driver delivers naturally vibrant midrange sound to the most critical part of the audible spectrum, while a newly developed C-CAM gold dome tweeter smoothly extends high frequency performance. Sheer control, wide-open dynamics and bandwidth compliment the sound of the RX8: a very big speaker disguised as a very slender one. Base plinths are supplied for added stability.

## RX-Centre

Reproducing up to 60% of a movie sound track, including the critical dialogue content is the job of a centre speaker. The exceptional RX-Centre proves the old adage that you get out what you put in. It has been very finely calibrated to match dynamics and timbre with other RX speakers for a wonderfully open, detailed and seamless front sound stage in any RX system configuration. We've tuned the RX Centre's multi-driver components to deliver the optimal combination of sonic virtue and size, so that the subtlety of whispers and the explosive force of action scenes are conveyed with equal priority by a compact design that's perfect for the role.

## RX-FX

The surround sound that leaks from televisions is a very poor substitute for the all-embracing, edge-of-the-seat excitement that's possible from a properly designed and equalised home theatre system. The perennial problem has been integration with living space. Monitor Audio's space-efficient RX speakers effortlessly enhance any décor, but the real deal-maker is the matching, wall-hugging RX-FX surround speaker. Discreet enough to be flush-mounted on side or rear walls, the RX-FX design will blend with the system to provide a convincing, enveloping timbre-consistent surround sound that places you at the heart of the action. It's also immensely flexible and can be set-up for direct or diffuse sound effects at the flick of a switch.





## POSITIONING

### AV Positioning

In the following pages, there are illustrations showing optimal positioning and some suggested room layouts for AV applications. For advice on configuring a 2 channel system, please refer to page 9.

The front, and in some cases rear, floor standing and stand mount speakers should be positioned approx 6 - 9 feet apart (1.8m - 2.5m) and start with them about 10 inches (25cm) from the wall.

If, when playing music, the sound is too bass heavy or there is bass boom from the room, then move them slightly further away from the rear/ corner walls. If this is not possible, then try the supplied port bungs (not included in the RX-FX or RX Centre). Refer to Page 12.

The RX Centre should be positioned so that it is pointing at you, in your viewing position, and at approximate ear height. If it is below or above ear height, use some rubber feet (small feet supplied) to angle it slightly.

The RX-FX's should be positioned in accordance with the below illustrations and approx 2 feet (60cm) above ear height when in your listening position.

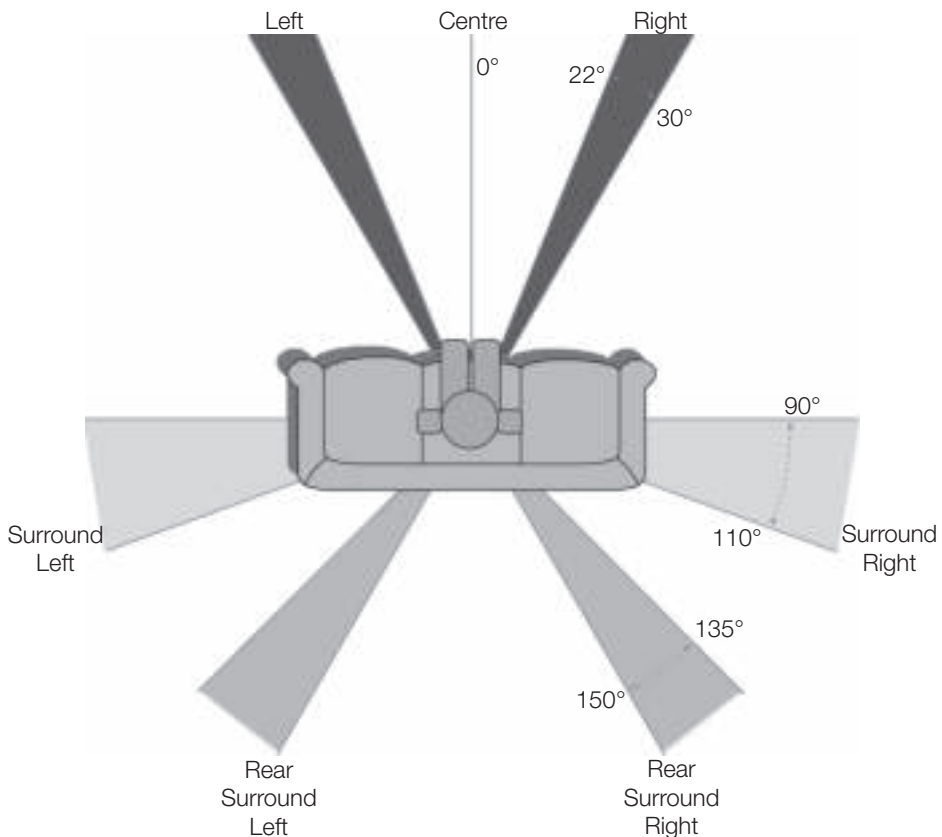



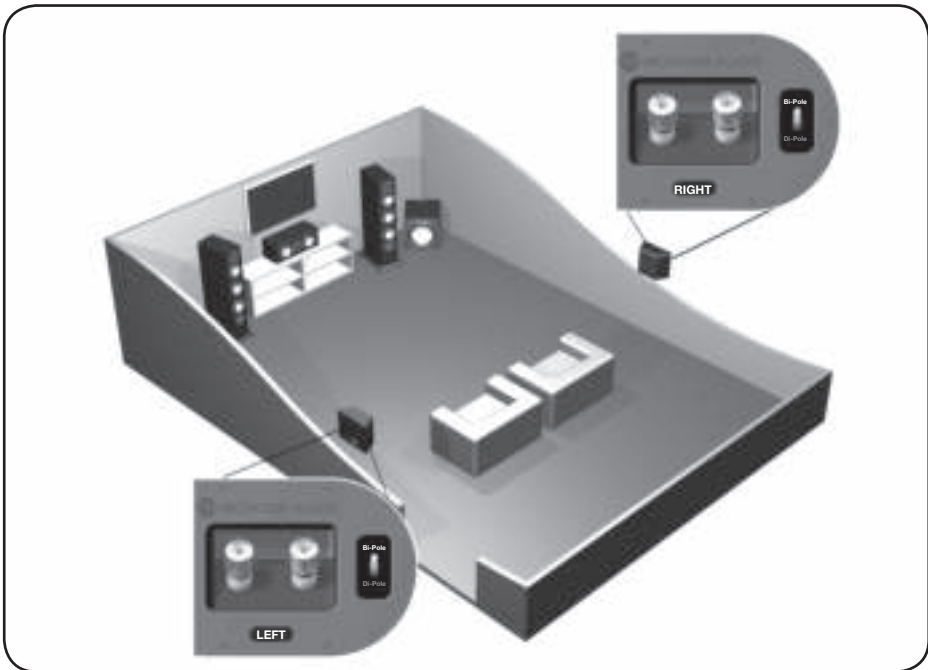
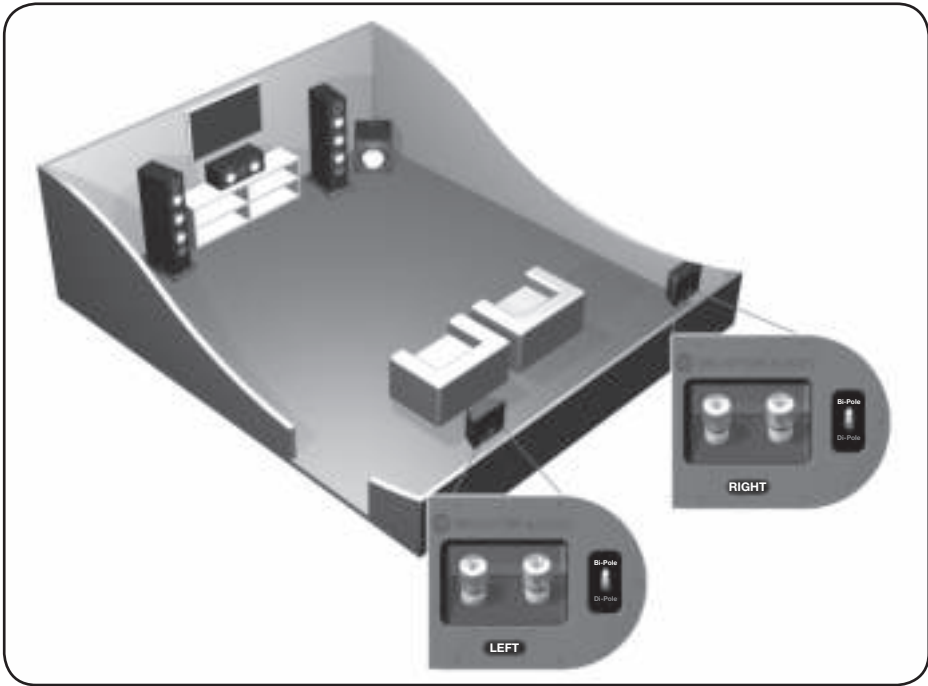

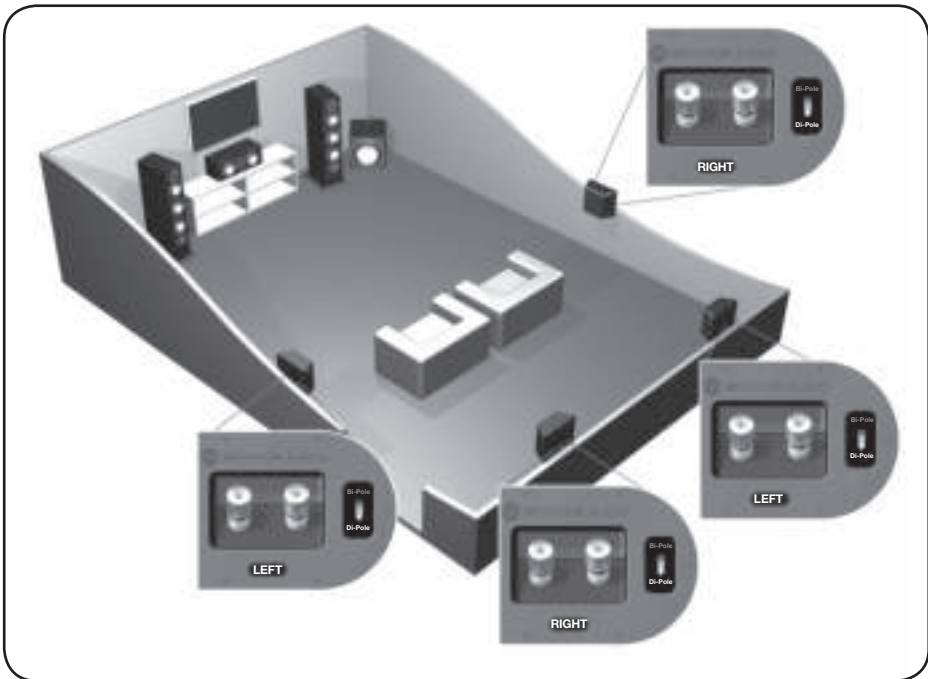
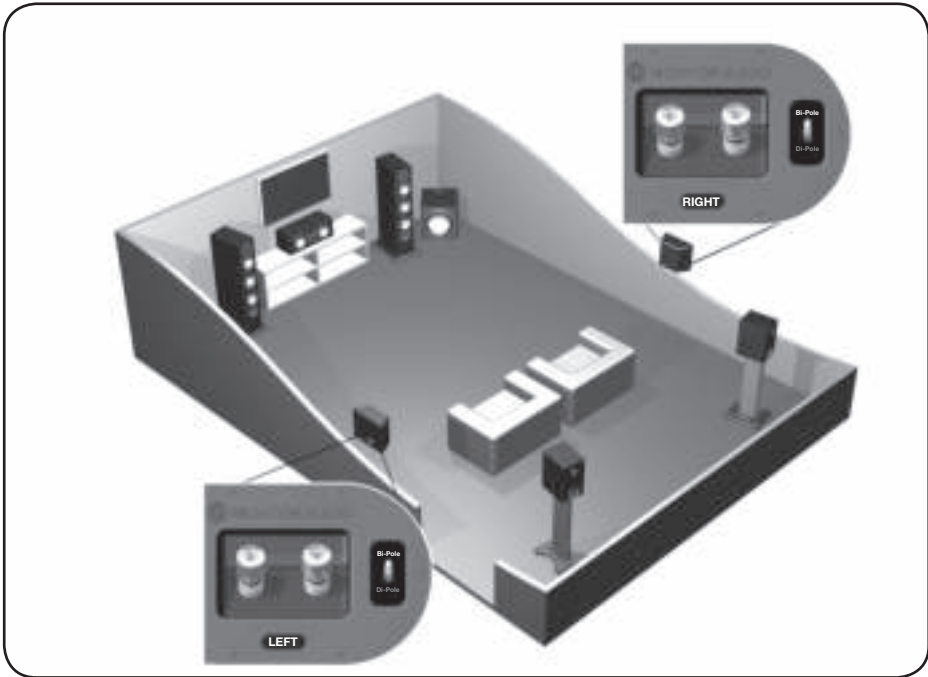



**NOTE: When using 2 pairs of RX-FX in a 7.1 system, you need to use the Right speaker for the rear surround left and the Left speaker for the rear surround right. This is because of the tweeter phasing.**

## 2 Channel Positioning

For use in a 2 channel system, the listening position and the loudspeakers should form an equilateral triangle. The speakers should be positioned approximately 6 - 10 feet (1.8 - 3m) apart. They ideally need to be between 8 - 18 inches (20 - 45cm) away from the rear and 3 feet (1m) from the side walls.

Experimentation is strongly advised when initially setting up your speakers, as environments and personal preference differ with each installation. If there is not enough bass, for example, then try moving your speakers closer to a wall. The opposite, if there is too much bass. Also see the information on page 12 referring to Port Bungs. If you are losing stereo imaging, try 'toeing' them in slightly. The sound should appear to originate from the centre point between the speakers, not the actual speakers themselves.

## SETTING UP THE RX-FX

The Silver RX-FX's are paired, but specifically, right hand and left hand units. Of which both can be configured to bi-pole (normal operation) or di-pole modes. The factory setting is bi-pole.

In bi-pole mode, all speaker units (mid/bass unit and tweeters) are in phase. This feature is designed for when the RX-FX is set up as a rear/surround speaker in a typical 5.1 channel system, or alternatively in a 7.1 channel system without a second pair of RX-FX's for rear/surround duties.

In di-pole mode, the front firing tweeters are out of phase with the other tweeter and mid/bass unit. It is best to implement this configuration when using the two pairs RX-FX as part of a 7.1 channel system, with the RX-FX's taking up positions on the side and rear walls. Please note that the RX-FX's are left and right handed. This is not an issue when used in bi-pole mode. It is essential that they are positioned correctly if used in a 7.1 channel system. Please refer to the positioning section on page 8.



**NOTE: Before changing your RX-FX's from bi-pole mode to di-pole mode, please ensure that the speaker wires are disconnected from your loudspeakers. This helps to protect your amplifier.**



## FIXING THE RX-FX TO A WALL



**CAUTION:** You will need to determine where the RX-FX will be fixed and the structure of the wall. For safety reasons, if you are unsure of your ability to provide a secure and safe fixing, do not attempt to fix these speakers to your wall, please obtain the services of a competent and qualified trades person.



**CAUTION:** Ensure that there are no water pipes or electricity cables running behind where the wall brackets are going to be secured. Work from secure steps and avoid trailing wires.

We do not supply wall fixing screws and plugs with the RX-FX. Please use suitable fixings for the type of wall construction the RX-FX's will be fixed to.

To fix your RX-FX's to the wall, we would recommend using the wall fixing template enclosed within the packaging carton

## PLINTH FIXING

(RX6 & RX8 only)

The Silver RX6 & RX8's are provided with plinths to improve stability and acoustic response. The plinths are secured in place by using the supplied M8 bolts.

Before you fit the plinth ensure the floor area is clear of any hard/sharp objects. To fit the plinth turn the cabinet over so that the bottom is facing upwards. Then, place the plinth onto the cabinet ensuring the plinth is orientated correctly, lining up the bolt holes in the plinth with the inserts in the cabinet. Using the bolts, secure the plinth to the cabinet. Tighten them up gradually at first and ensure the plinth is fitted securely to the cabinet. Fit the feet to the plinth before turning the loudspeaker back over. (Please read the instructions opposite). The spikes are used to improve sound quality and bass performance

## GRILLES

All of the Silver RX speakers come with grilles covered in acoustically transparent cloth. The grilles are held invisibly in place by magnets in both the grille and the cabinet (except RX-FX).

To fit them, firstly ensure they are the correct way up (badge at the bottom) and offer them up to the cabinet. The magnets should then pull it into position.

The RX-FX comes with the grilles factory fitted. If you wish to remove them, carefully prize them away from the cabinet with the tips of your fingers. There are three separate grilles fitted to each RX-FX cabinet.



**CAUTION:** Do not lift or move the loudspeaker with the grilles fitted. If any movement needs to be done, please remove the grilles first.





## SPIKED FOOT

### For Carpeted Floors

(Silver RX6 & RX8 only)

The Silver RX spiked foot incorporates a spike for use on carpeted floors and also, a soft polymer pad for use on wooden or tiled floors.

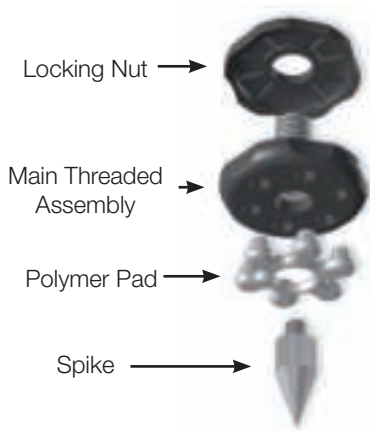

Please ensure there are no hidden wires under the carpet that could be damaged by the spikes.

The foot comes fully assembled for use on carpeted floors. All that is required is fixing into the plinth. This is achieved by screwing the feet fully into the 4-threaded insert in the underside of the plinth. If your carpet has a very thick pile, remove the soft polymer pad from the foot to ensure the spike goes right through the carpet into the floor. With great care turn your cabinet the right way up. Place the cabinet in your desired location, and check that it is level on all sides. If it is slightly off level, unscrew the spike at the lowest point and check again. Continue this process until the cabinet is fully level. Use the locking nut on the foot to fix the foot in place and to stop any unwanted vibrations.

### For Wooden/Hard Floors

(Silver RX6 & RX8 only)

For use on solid floors or where spikes are inappropriate, it is possible to use the foot without the spike insert. To use the foot in this manner carefully grip the knurled portion of the spike and rotate anti clockwise to unscrew the spike fully.

You may find it easier to first remove the polymer pad so as to gain more purchase on the spike. The pad should be replaced before carrying out the levelling operation described above.





## PORT BUNGS



**WARNING:** Care must be taken not to insert the port bungs too far into the port as this may result in the foam bung being lost inside the cabinet.

If the loudspeaker is to be used in a small room, typically 9 sqM ( 80 sqFT) or a room that is known to reproduce accentuated bass response, it may be desirable to fit the port bungs. However, before this is done it is worth experimenting with the positioning of the loudspeaker in the room. To reproduce the optimum performance from the loudspeaker it is important to make sure the loudspeaker is not positioned too close to a wall (typically 150mm / 6" from the back of the cabinet) or near corners of a room (typically 1M / 3FT).

If the room is larger than detailed above and no problems are known, please read point 1. If the positioning of the loudspeaker is predetermined by room aesthetics or layout, please move on and read point 2 for the RX1/ RX2 and point 3 for the RX6/ RX8.

1. If you can adhere to the room characteristics detailed above we recommend that you do not fit the port bungs to achieve the best performance. However you may feel that by fitting the bungs even under these circumstances provides you with a degree of fine-tuning to suite particular taste. Experimentation is highly recommended.
2. Where a bookshelf/ stand-mount speaker (RX1 & RX2) is to be used in close proximity (2", 50mm) to a rear wall such as on a bookshelf, positioned in a cabinet or mounted on a wall, we recommend fitting the port bungs to the ports. This will reduce the bass 'boom' sometimes termed as overhang, and assist the loudspeaker to reproduce its best performance under the environmental constraints. 'Boom' is generally caused when bass energy from the loudspeaker 'excites' room modes and causes an accentuation at a particular frequency, or number of frequencies.
3. Where a floor-standing loudspeaker (RX6 & RX8) is to be used in close proximity (closer than 150mm 6") to a rear wall, we recommend fitting the port bungs. This will reduce the bass 'boom' sometimes termed as overhang and assist the loudspeaker to reproduce its best performance under these environmental constraints. This is caused when bass energy from the loudspeaker 'excites' room modes and causes an accentuation at a particular frequency, or number of frequencies.

Where the loudspeaker has two ports per speaker, RX6 and RX8, a further degree of fine-tuning is provided. In this case you have three options; to leave all the ports open (point 1), fit the port bungs to the rear ports or to fit a port bung to the front port. We recommend that you experiment with fitting the port bungs to the rear port or the front port in succession as the results can vary dependant on room acoustics and positioning. The overall bass extension will not be reduced, however the bass energy/ output around the port tuning frequency will be reduced. This has the effect of reducing bass 'boom' increasing bass clarity and apparent agility. Experimentation is highly recommended.





# SPECIFICATIONS

Model	RX1	RX2	RX6	RX8	RX-Centre	RX-FX
<b>System Format</b>	2 Way	2 Way	2 1/2 Way	3 Way	2 1/2 Way	2 Way
<b>Frequency Response</b>	45Hz - 35kHz	40Hz - 35kHz	38Hz - 35kHz	32Hz - 35kHz	45Hz - 35kHz	60Hz - 35kHz
<b>Sensitivity (1w @ 1m)</b>	89dB	90dB	90dB	90dB	90dB	89dB
<b>Nominal Impedance</b>	6 Ohms	6 Ohms	6 Ohms	4 Ohms	6 Ohms	6 Ohms
<b>Maximum SPL (dBA)</b>	111.8	113.8	114.8	116.2	114.8	111.8
<b>Power Handling (RMS)</b>	80W	100W	125W	175W	125W	80W
<b>Recommended Amp Requirements</b>	25 - 80W	25 - 100W	40 - 125W	50 - 175W	40 - 125W	10 - 80W
<b>Bass Alignment</b>	Bass reflex - rear ported. HiVe® port System	Bass reflex - rear ported. HiVe® port System	Dual Chamber, Bass reflex with differential tuning. Twin HiVe® port System	Bass reflex. Twin HiVe® port System	Sealed Cabinet	Sealed Cabinet
<b>Crossover Frequency</b>	3.0kHz	2.0kHz	LF: 700Hz MF/HF: 2.7kHz	LF/MF: 300Hz MF/HF: 2.2kHz	LF: 500Hz MF/HF: 3.0kHz	2.1kHz
<b>Drive unit Complement</b>	1 x 6" RST® Bass/Mid driver. 1 x 1" (25mm) C-CAM® gold dome tweeter	1 x 8" RST® Bass/ Mid driver. 1 x 1" (25mm) C-CAM® gold dome tweeter	1 x 6" RST® Bass driver. 1 x 6" RST® Bass/ Mid driver. 1 x 1" (25mm) C-CAM gold dome tweeter	2 x 6" RST® Bass drivers. 1 x 6" RST® Bass/ Mid driver. 1 x 1" (25mm) C-CAM gold dome tweeter	1 x 6" RST® Bass driver. 1 x 6" RST® Bass/ Mid driver. 1 x 1" (25mm) C-CAM gold dome tweeter	1 x 6" RST® Bass/ Mid driver. 2 x 1" (25mm) C-CAM® gold dome tweeters
<b>External Dimension H x W x D (mm &amp; inch)</b>	312 x 185 x 240mm 12 5/16 x 7 5/16 x 9 7/16"	375 x 230 x 300mm 14 3/4 x 9 1/16 x 11 13/16"	850 x 185 x 250mm 33 7/16 x 7 5/16 x 9 13/16"	900 x 185 x 330mm 35 7/16 x 7 5/16 x 13"	185 x 500 x 200mm 7 5/16 x 19 11/16 x 7 7/8"	300 x 120 x 250mm 11 13/16 x 4 3/4 x 9 13/16"
<b>Plinth Dimensions H x W x D (mm &amp; inch)</b>	N/A	N/A	25 x 265 x 310mm 1 x 10 7/16 x 12 3/16"	25 x 265 x 388mm 1 x 10 7/16 x 15 1/4"	N/A	N/A
<b>Weight (each) Kg (lb)</b>	6.8 (15)	9.5 (20.88)	16.4 (36.13)	21.76 (47.88)	9.62 (21.13)	4.69 (10.38)





## GUARANTEE AND SERVICE

To validate your warranty please visit [www.monitoraudio.co.uk](http://www.monitoraudio.co.uk) within 30 days of purchase.

When you register online you'll gain free entry to our monthly prize draw! What's more you'll be the first to hear about the great things happening at Monitor Audio, including new products and events!

This equipment has been fully tested prior to dispatch from the factory. Both the craftsmanship and the performance of this product is guaranteed against manufacturing defects for the period of **three years** from the date of purchase (see conditions below), provided that the product was supplied by an authorised Monitor Audio retailer under the consumer sale agreement. (The words 'consumer sale' shall be construed in accordance with section 15 of the supply of goods act 1973). Monitor Audio accepts no responsibility for defects arising from accident, misuse, abuse, wear and tear, modification or operation outside of that specified within this instruction manual. Neither will responsibility be accepted for damage or loss occurring during transit to or from the parties claiming under this guarantee.

This guarantee covers both labour and parts. The liability of Monitor Audio is limited to the cost of repair or replacement of the defective parts (at the discretion of Monitor Audio) and under no circumstances extends to consequential losses or damage.

## CLAIMS UNDER THIS GUARANTEE

The equipment should be returned in its original packaging to the original supplier where possible, or to any other authorised Monitor Audio dealer. If it is not possible to return the equipment by hand, then it should be sent carriage prepaid via a reputable carrier. If the original packing is not available replacement packaging can be purchased from Monitor Audio.

If you have any difficulties complying with these requirements please contact us at the following address:

Customer Service  
Monitor Audio Ltd.  
24 Brook Road  
Rayleigh  
Essex  
SS6 7XJ  
England

Tel: +44 (0)1268 740580  
Fax: +44 (0)1268 740589  
Internet: [www.monitoraudio.co.uk](http://www.monitoraudio.co.uk)  
Email: [info@monitoraudio.co.uk](mailto:info@monitoraudio.co.uk)

This guarantee does not affect the statutory rights of the consumer under UK law.







## DATA PROTECTION

We at Monitor Audio are committed to respecting the wishes and privacy of our customers. Any information you provide will be held in the strictest confidence and only used within the Monitor Audio organisation for the provision of services such as warranty claims or spare parts.

We may wish to contact you in the future to ensure you are happy with the products and standards of service we provide and to keep you up-to-date with the latest products and promotions we have to offer.

Should you wish not to be contacted by us either by post, e-mail or phone, please tick the box on the warranty form on the web site. Alternatively you can request not to be contacted in future by writing to Customer Service, at the address above.

## OWNER INFORMATION

### **Product Details**

Model .....

Product Serial No .....

Date of Purchase .....

### **Dealer Details**

Dealer Name .....

Address .....

.....

e-mail address .....

Telephone Number .....

Monitor Audio reserves the right to alter specifications without notice.





## EC Declaration of Conformity

We, Monitor Audio Ltd.  
24 Brook Road  
Rayleigh  
Essex  
SS6 7XJ  
England



Declare in own responsibility, that the Silver RX products described in this manual is in compliance with Technical Standards/Council Directives:

### **(LVD) 2006/95/EC Low Voltage Directive**

**EN60065: 2002+A1:** 2006 Safety requirements for mains operated electronic and related apparatus for household and similar use.

### **(EMC) 89/336/EEC Electro Magnetic Compatibility**

**EN55013: 08.90+A12:08.94+A13:12.96** Limits and methods of measurement of radio disturbance characteristics of broadcast receivers and associated equipment.

**EN55020: 12.94+A11:12.96** Electro magnetic immunity of broadcast receivers and associated equipment.

**EN61000-3-2: 04.95+A1:1998+A2:1998** Electro magnetic compatibility (EMC) – Part 3: Limits – Section 2: Limits for harmonic current emissions (equipment input current up to and including 16 Ampere per phase).

**EN6100-3-3: 01.95** Electro magnetic compatibility (EMC) – Part 3: Limits – Section 3: Limits of voltage fluctuations and flicker in low-voltage supply systems for equipment with rated current up and including 16 Ampere per phase.

**Signed by:**

**Name:** D.S. Hartley

**Position:** Technical Director

**Company:** Monitor Audio Ltd







Monitor Audio Ltd.  
Unit 2, 24 Brook Road  
Rayleigh, Essex  
SS6 7XJ  
England  
Tel: +44 (0)1268 740580  
Fax: +44 (0)1268 740589  
Email: [info@monitoraudio.co.uk](mailto:info@monitoraudio.co.uk)  
**monitoraudio.co.uk**  
Designed in the United Kingdom

© 2009. Version 1

