

alpha® open air

Instructions for use



Safety precautions

- Your telephone is a wall-mounted telephone and designed for operation on an analogue telephone line (analogue access with standard requirements) via the plug of the telephone connecting cord. It can be connected to main lines and extensions.
- Always remove the plug of the telephone connecting cord from the wall socket before opening the **alpha open air!** (Exception: when programming the unit. Only the SET key located on the main board of the phone may be actuated (see drawing 4).)
- Allow repairs by authorized specialists only!
- Do not use or install your phone in rooms with danger of explosion and near electromagnetic fields (e. g. domestic appliances, TV sets or video recorders)!
- The last step when beginning operation is to plug the telephone connecting cord into the wall socket!
- The first step when ending operation is to remove the plug of the telephone connecting cord from the wall socket!
- The telephone connecting cord is only to be plugged into the designated socket!
- The telephone connecting cord is immediately to be removed from the socket if there is danger of touching conductive parts due to improper use!
- Using the phone during thunderstorms is on one's own risk!
- Your telephone should only be passed on to third parties if the operating instructions are included!
- When the telephone has reached the end of its service life, it should be disposed of in an environmentally friendly manner!
- Danger in case of noncompliance with safety precautions
Your telephone is state of the art. However, it may be dangerous if the telephone is not mounted and installed by qualified personnel.
- Prohibition to make any changes or modifications
The mechanical design as well as all safety-related matters of the telephone may not be changed or modified without prior and express consent of the manufacturer. In no event shall FMN be liable for any damages caused by such unauthorized modification of the unit. Especially all kinds of repair and soldering works on the main board (PCB) are prohibited.

ESD protection measures

Comply with the ESC protection measures according to DIN EN 61340-5-1/-2 when opening the unit (potential equalization between body and ground of the unit as well as ground of the casing via high-value resistance (approx. 1 MOhm) e. g. usual wrist band).



Table of contents

Safety precautions	2
Table of contents	3
Versions of the alpha open air / Mounting	4
1. Versions of the alpha open air	4
2. Delivery scope	4
3. Mounting instructions	4
3.1 Mounting on a wall with cable entry at the bottom of the casing	4
3.2 Mounting on a wall with the cable leading through the back panel of the casing	5
Installation	6
4. Installation	6
Telephone with 4 destination dialling keys	7
5. Settings	7
5.1 Notes	7
5.2 Telephone with 4 destination dialling keys	7
5.2.1 Default setting	7
5.2.2 Normal telephone function (Default setting)	8
5.2.3 Programming the flash key	8
5.2.4 Programming manual direct station selection	8
5.2.5 Programming automatic direct station selection	9
5.2.6 Programming the destination dialling keys	9
Telephone with automatic direct station selection	9
5.3 Telephone with automatic direct station selection	10
5.3.1 Default setting	10
5.3.2 Programming the destination dialling key	10
Connection permit/Warranty/Consumer Advice/Conformity	10
6. Connection permit	10
7. Warranty	11
8. Consumer Advice	11
9. Conformity	11

1. Versions of the alpha open air

Following versions are covered by these instructions for use:

alpha open air with 4 destination dialling keys

telephone with 4 programmable destination dialling keys; can be used in several operating modes (see point 5.2)

alpha open air without keypad (automatic direct station selection)

with automatic direct station selection, when lifting the handset the number preprogrammed in the telephone is automatically dialled out (see point 5.3)

Mounting and installation of both versions is according to points 3 and 4. Features of each version and their programming are described in point 5.

2. Delivery scope

- 1 alpha open air
- 1 folding ferrite
- 1 instructions for use
- 1 offset screw driver
- 4 hexagon head wood screws 6x50
- 4 sealing washers (plastic)
- 4 washers (steel)

3. Mounting instructions

You can mount the **alpha open air** on a wall or a pole.

It can be mounted on a pole using two mounting clips (not within the delivery scope) which are screwed on the 4 fixing holes of the back panel of the casing.

The cable entry for the telephone connecting cord is foreseen at the bottom of the back compartment (as supplied). It can also be lead through the back panel of the back compartment if the telephone connecting cord is not to be accessible from outside. Please follow the instructions below:

3.1 Mounting on a wall with cable entry at the bottom of the casing

1. Mark the 4 fixing points on the wall according to drawing 1 or the drilling template (see last page of instructions).
2. For mounting on a solid wall: drill holes into the marked fixing points and put dowels into the drilled holes (e. g. 8 mm dowels); for mounting on a wood wall etc.: drill holes (\varnothing 4 mm) into the marked fixing points.
3. Take the **alpha open air** out of the packaging. Remove the front panel from the back compartment by loosening the 4 Security-TORX screws (tool: offset screw driver). Unplug the connector of the handset and the telephone connecting cord from the main board (PCB), lay the front panel aside.
4. Fix the back compartment of the casing into the wall using the 4 hexagon head wood screws supplied each together with one steel and one plastic washer (for sealing purposes); further with point 4: Installation.

Mounting

3.2 Mounting on a wall with the cable leading through the back panel of the casing

1. Mark 4 fixing points and the drilling for the cable leading (back panel) on the wall according to drawing 1 or the drilling template (see last page of instructions).
2. For mounting on a solid wall: drill holes into the marked fixing points and put dowels into the drilled holes (e. g. 8 mm dowels);
for mounting on a wood wall etc.: drill holes $\varnothing 4$ mm into the marked fixing points.
3. Cable entry on the back panel: drill a hole (min. $\varnothing 6$ mm) into the marked point.
4. Take the **alpha open air** out of the packaging. Remove the front panel from the back compartment by loosening the 4 Security-TORX screws (tool: offset screw driver). Unplug the connector of the handset and the telephone connecting cord from the main board (PCB), lay the front panel aside.
5. Remove the connecting cord by unscrewing the 2 pin screw terminal, pull the cord out of the ferrite ring, the protection sleeve remains in the casing. Pull the connecting cord through the drill hole in the fixing panel and through the protection sleeve in the back panel. Pull the cord twice through the ferrite ring and screw it back onto the 2 pin screw terminal.
6. Fix the back compartment of the casing to the wall using the 4 hexagon head wood screws supplied each together with one steel and one plastic washer (for sealing purposes).

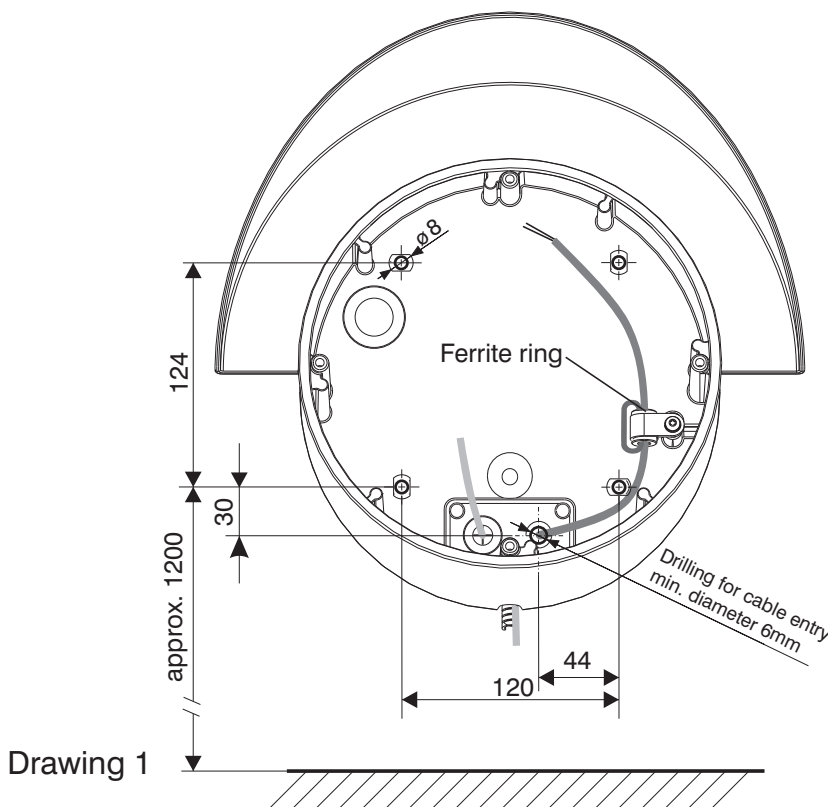

Dimensions with protection-frame:
height: 332 mm
(without handset cord)
width: 326 mm
depth: 130mm (with handset)

Dimensions without protection-frame:
height: 260 mm
(without handset cord)
width: 250 mm
depth: 130mm (with handset)

Drawing 1

Installation

4. Installation

1. Plug the connectors of the telephone connecting cord and the handset cord back onto the main board; place the folding ferrite supplied at least 10 cm behind the end of the armoured metal handset cord (according to drawings 2 / 3) and snap it into place. (Note: Take care of the distance of at least 10 cm when assembling the phone. The handset cord needs to be laid in a loop into the casing.)
2. If you do not want to change the settings (see point 5 Settings) fix the front panel back onto the casing using the 4 Security-TORX screws. (tool: offset screw driver)
3. Plug the plug of the connecting cord back into the telephone socket.

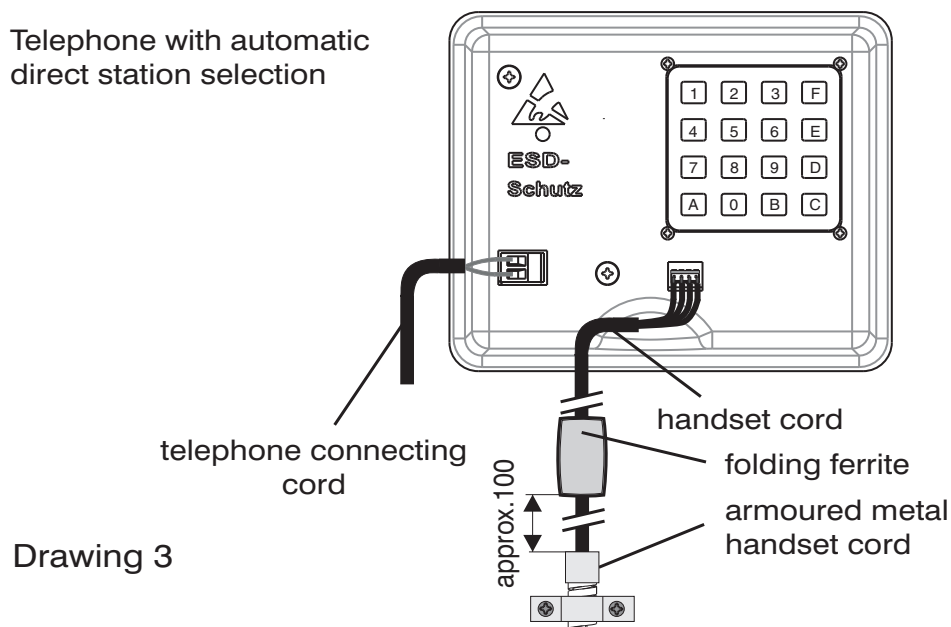
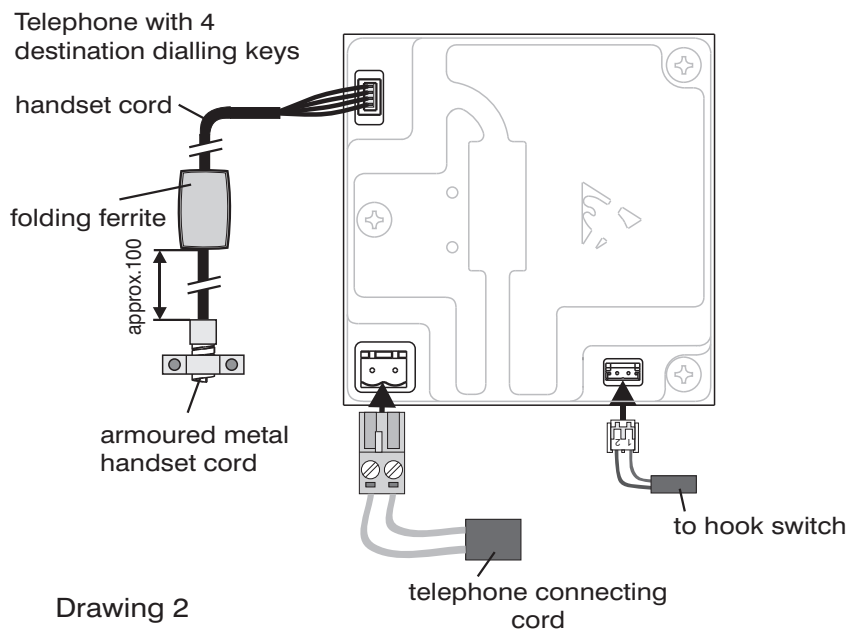

Each version of the **alpha open air** has a different default setting. The default settings are described in points 5.2.1 and 5.3.1. If you want to make any changes, follow the instructions on the following pages.

Telephone with 4 destination dialling keys

5. Settings

The **alpha open air** needs to be opened in order to be able to make settings and program the destination dialling keys (remove the front panel from the casing by unscrewing the 4 Security-TORX screws).

5.1 Notes

- The destination dialling memories are automatically cleared if the operation mode is changed. They need to be programmed anew if required.
- According to point 5.2.5, the telephone will be in working condition if the destination dialling key 1 (or A see drawing 3) is programmed with a call number.
- Changes of settings become effective by replacing the handset.
- The telephone can only be programmed when it is connected to the telephone line.
- The Set key can be pressed by using a small screw driver or a similar tool.
- All settings remain when the telephone is disconnected from the telephone line.
- **Important:** This telephone does not have a ringer, also pulse dialling, ground and last number redial are not possible.

5.2 Telephone with 4 destination dialling keys

Description of the operating panel: telephone with 4 destination dialling keys

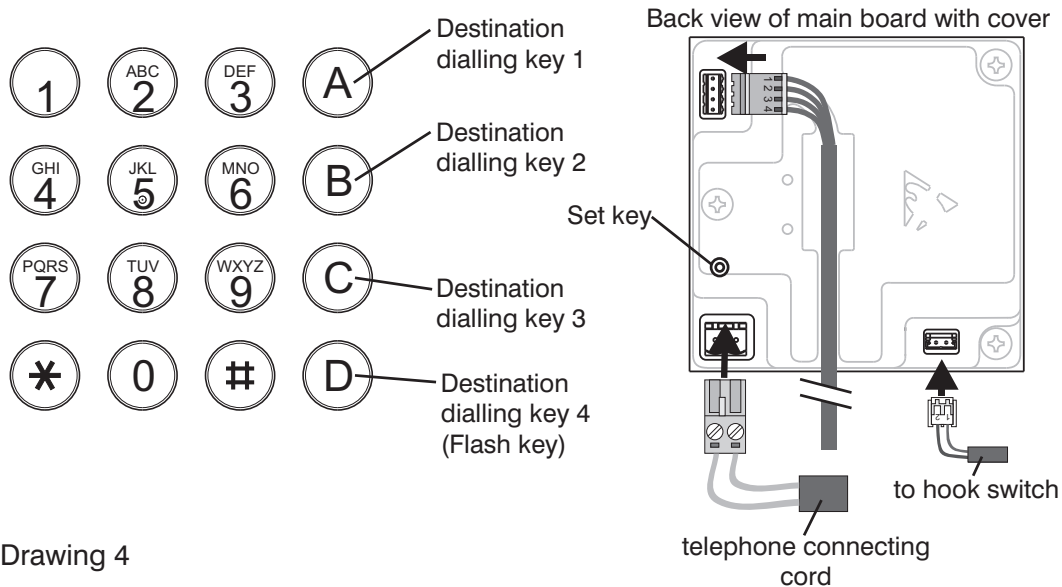

Drawing 4

5.2.1 Default setting

- Analogue standard telephone with DTMF dialling without reservation
- 4 destination dialling memories with a maximum of 20 digits each (empty)

5.2.2 Normal telephone function (default setting)

Dialling and communication is possible without reservation.

If your telephone is set in accordance with points 5.2.3 - 5.2.5, you can reset it to normal telephone function (default setting) as follows:

Telephone with 4 destination dialling keys

- handset is off-hook
- press Set key (see drawing 3)
- press Digit key 1
- press Set key

5.2.3 Programming the flash key

The second destination dialling key has a double function. It is the flash key in this mode. The flash time can be set. Dialling and communication is possible without reservation.

Setting:

- handset is off-hook
- press Set key
- press digit key 2
- press Set key

Setting the flash time:

- handset is off-hook
- press Set key
- press Digit key 0 and the relevant code (0 to 7, see below)
- press Set key

Codes and their meaning:

- | | |
|-----------|-------------------------------------|
| - Code 0: | Flash time: 80 ms |
| - Code 1: | Flash time: 90 ms (default setting) |
| - Code 2: | Flash time: 120 ms |
| - Code 3: | Flash time: 180 ms |
| - Code 4: | Flash time: 240 ms |
| - Code 5: | Flash time: 300 ms |
| - Code 6: | Flash time: 360 ms |
| - Code 7: | Flash time: 480 ms |

5.2.4 Programming manual direct station selection

Four destination dialling keys are available (for programming destination dialling keys 1 to 4 see Point 5.2.6). Generally, dialling must be started via one of the destination dialling keys. The handset microphone is deactivated until then. Once the destination dialling key is pressed, the microphone is activated and the keypad unlocked. It then can be used without reservation.

Setting:

- handset is off-hook
- press Set key
- press Digit key 3
- press Set key

5.2.5 Programming automatic direct station selection

Automatic direct station selection is activated by lifting the handset. The number pre-programmed on the destination dialling key 1 is dialled out automatically (see point 5.2.6). Once the number of destination dialling key 1 is dialled out, the microphone is activated and the keypad is unlocked. It can be used without reservation.

Setting:

- handset is off-hook
- press Set key
- press Digit key 4
- press Set key

Note: The telephone is in working condition if the destination dialling key 1 is programmed with a call number.

5.2.6 Programming the destination dialling keys

Setting:

- handset is off-hook
- press Set key
- press Destination dialling key 1, 2, 3 or 4
- enter number (previously programmed numbers will be overwritten)
- press Set key

5.3 Telephone with automatic direct station selection

In addition to point 5.1 please note the following:

- The telephone will be in working condition if key F is programmed with a call number.
- Important: This telephone does not have a ringer, also pulse dialling, ground, flash and last number redial are not possible.

One destination dialling key is available. Automatic direct station selection is activated when the handset is lifted. The number preprogrammed in the destination dialling memory is dialled out automatically (for programming the destination dialling memory, see point 5.3.2). Once the number is dialled out, the microphone is activated.

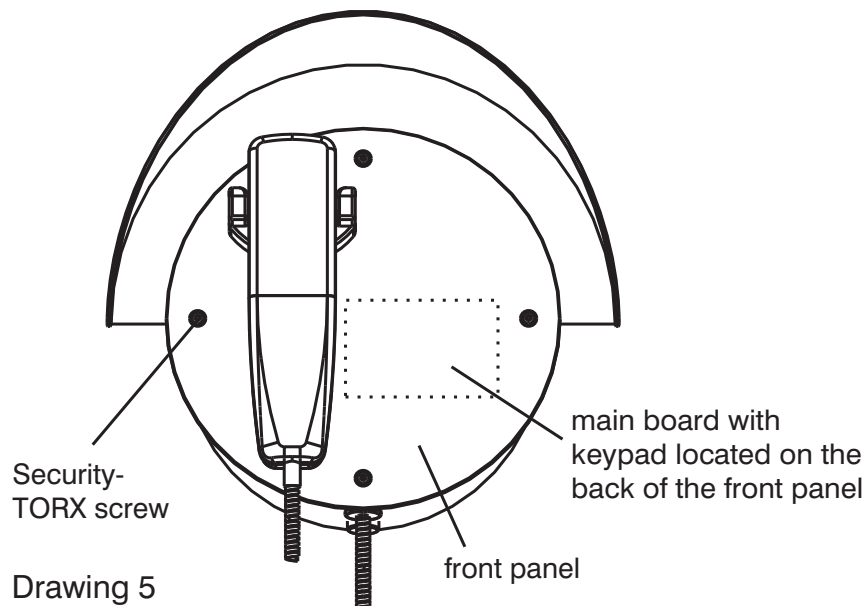

Description of the operating panel

Back view of main board

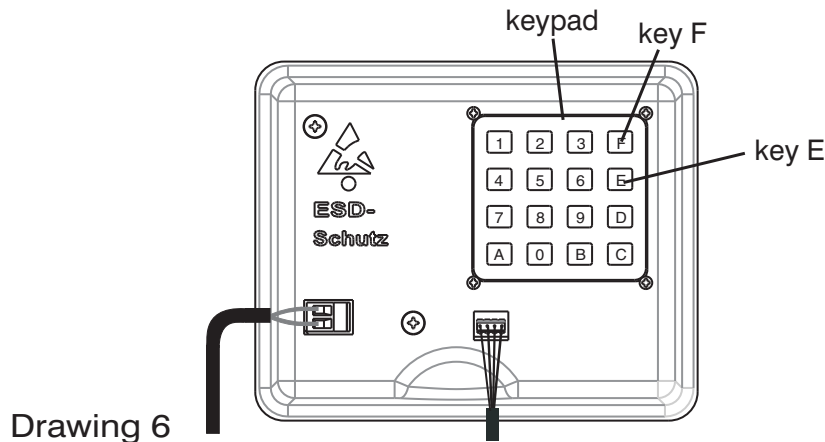

5.3.1 Default setting

- telephone with automatic direct station selection - DTMF dialling
- 1 destination dialling memory with a maximum of 20 digits, (the memory is empty or preprogrammed by default with a call number (option))

5.3.2 Programming the destination dialling key

- remove the front panel (see drawing 5)
- lift the handset
- press key E of the keypad located on the back of the front panel (see drawing 6)
- press key F of the keypad (= destination dialling key)
- enter number (previously programmed call numbers will be overwritten)
- press key E of the keypad
- replace the handset after fixing the front panel to the back compartment.

6. Connection permit

This telephone is designed for connection to analogue telephone lines (analogue access with standard requirements) of the public telecommunications network. It may be connected and operated by any person.

The telephone is compliant with the harmonized standards for connection to public telecommunications networks.

This, however, is no guarantee for successful operation of the telephone unit on each network termination point due to the differences in the public telecommunications network between the different countries.

For operating problems, contact your specialist dealer.

7. Warranty

- The liability for defects and other damages complies with the regulations of our general conditions of supply and terms of trade.
- Claims based on defects are subject to a limitation period of 12 months, as far as the law - particularly Sec. 479 para. 1 German Civil Code (“BGB”) (rights of recourse) - does not prescribe longer terms.
All parts or services where a defect as to quality becomes apparent within the limitation period shall, at our discretion, be repaired, replaced or provided again free of charge provided that the reason for the defect had already existed at the time when the risk passed. In case that the customer is consumer in terms of Sec. 3 German Civil Code, the legal requirements apply.
- Other claims for reimbursement of expenses, based on whatever legal reason, including infringement of duties arising in connection with the contract or tort, shall be excluded, as far as mandatory liability shall not apply, e. g. according to the German Product Liability Act (“Produkthaftungsgesetz”), in the case of intent, gross negligence, injury of life, body or health, or breach of a condition which goes to the root of the contract (“wesentliche Vertragspflichten”).
- Damages caused by improper use, operation, storage, maintenance as well as by influences beyond one’s control or other outside influences, do not come under the warranty, furthermore not the consumption of consumer goods.
- Claims based on defects attributable to improper modifications or repair work carried out by the purchaser or third parties and the consequences shall likewise be excluded.

8. Consumer advice

In case that our customer is **consumer** in terms of Sec. 13 German Civil Code, an absolute right of return of 2 weeks after receipt of the goods - without giving any reasons - is granted according to Sec. 356 German Civil code.

For the observance of the prescribed period, it is sufficient to send back the goods within the prescribed period or to send the written request for return to

FMN communications GmbH, Grimmelallee 4, 99734 Nordhausen. In case the goods have a value of up to 40 Euro, the regular costs of sending back the goods will have to be paid by the consumer.

9. Conformity

The FMN communications GmbH declares that the telephone “alpha open air” complies with the essential requirements and the other relevant provisions of the directive 1999/5/EG (R&TTE Directive).

The complete declaration of conformity can be found and downloaded on our website <http://www.fmncom.com>.

Copyright

All rights reserved. Duplication of these instructions for use or parts thereof by any reproduction method whatsoever is not permitted without prior permission of the manufacturer.

Amendments may be published without prior notification.

Notwithstanding the above declaration, the manufacturer accepts no liability for errors in these instructions or their consequences.

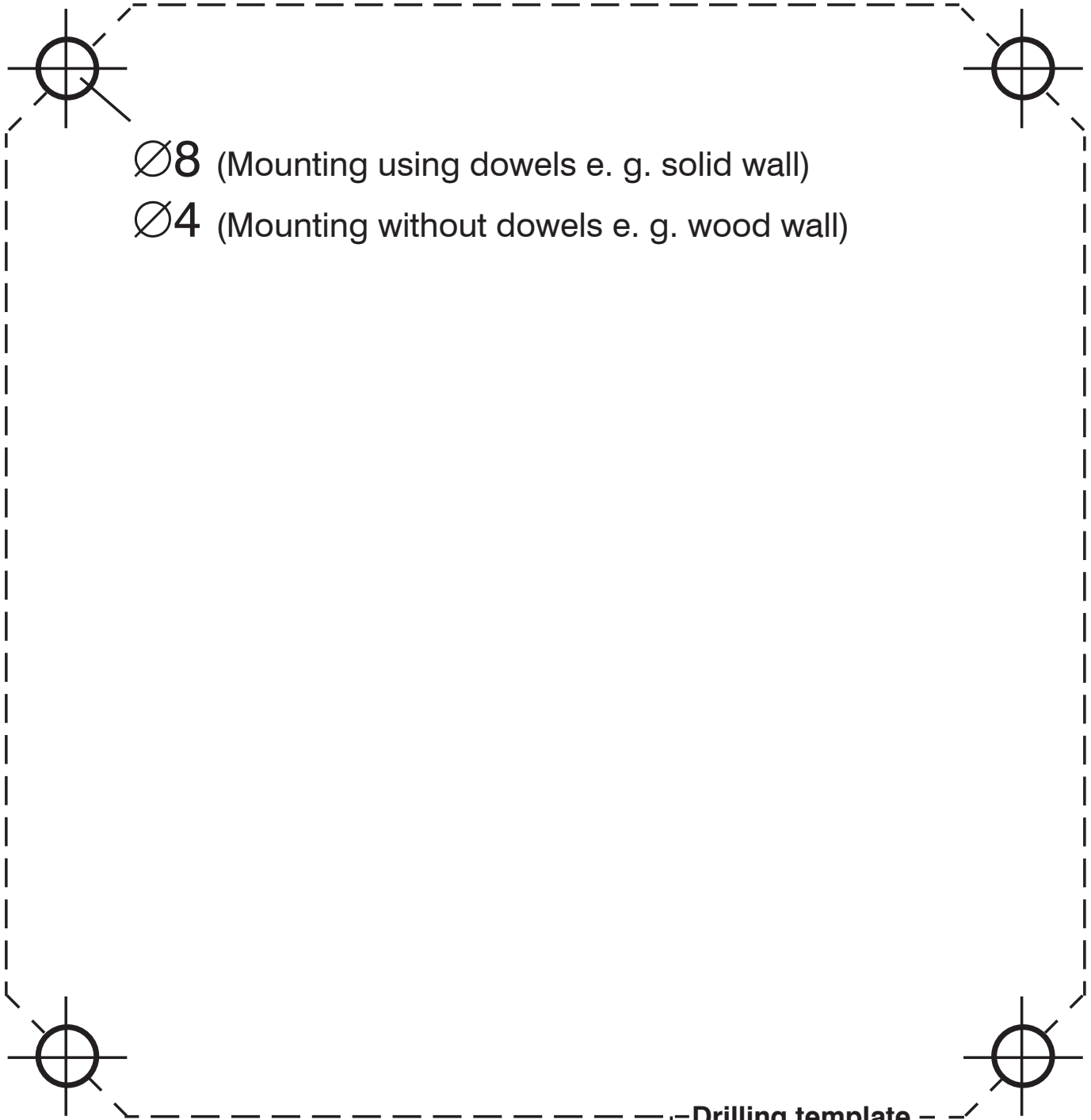

Ø8 (Mounting using dowels e. g. solid wall)

Ø4 (Mounting without dowels e. g. wood wall)

Drilling template

FMN communications GmbH

Grimmelallee 4

P. O. Box 10 04 65

Phone

Fax

Email

Internet

HOTLINE

99734 Nordhausen

99724 Nordhausen

+49 (36 31) 56-50 00

+49 (36 31) 56-32 24

info@fmn.de

www.fmncom.com

+49 (36 31) 56-34 16

We are at your disposal to answer your questions.

min. Ø6



Subject to change.

Instructions for use 2006.3.0160.02

Edition: No. 05/09 (1111-5385)