

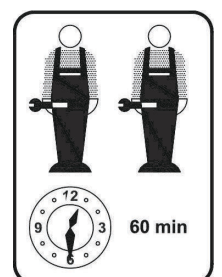

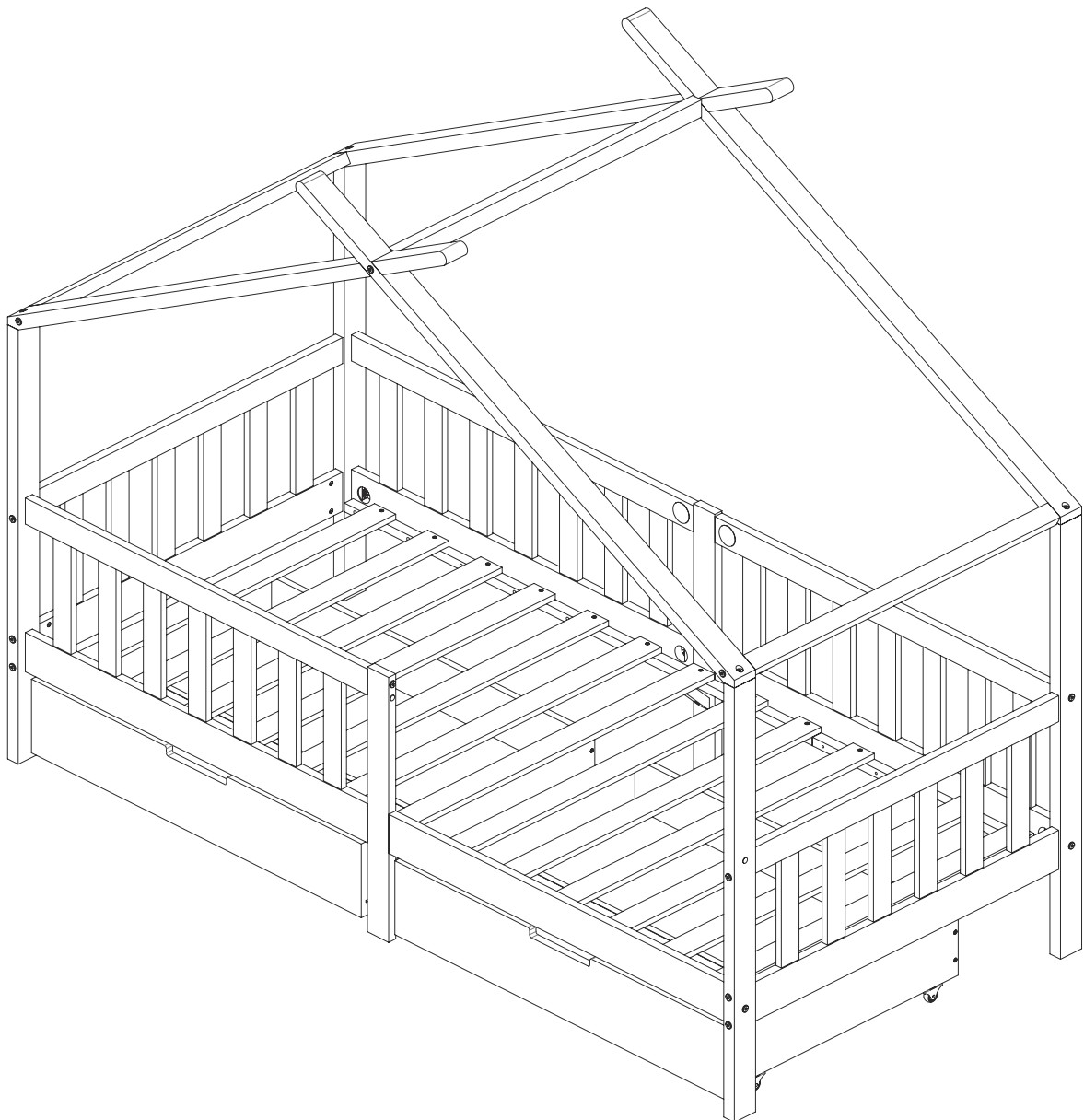

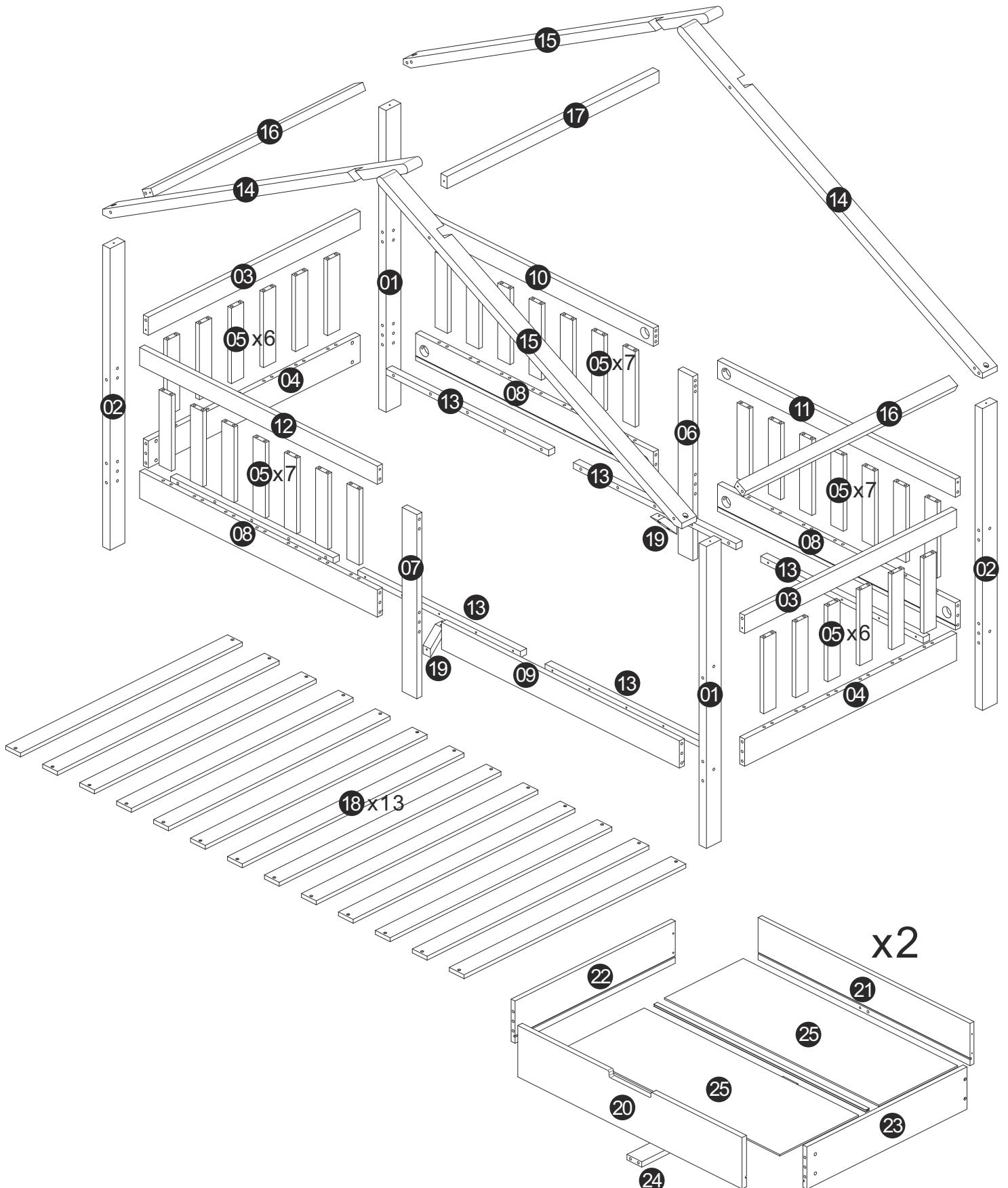





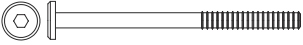

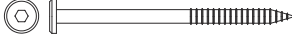

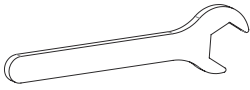
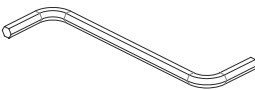

WF281830AAW

Hausbett Kinderbett mit Zaun 200x90cm

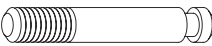

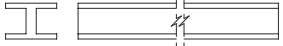
Stückliste

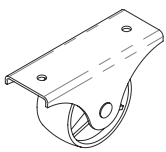

A x8  M6x100	B x8 	C x11  Φ6x100	D x4  M6x80
E x7  Φ6x80	F x3  M6x140	G x10 	H x176  Φ8x30
J x60  Φ4x30	K x1 	L x1 	M x4 
N x2 	P x12 	Q x8  Φ4x40	R x2  880mm
S x12 	T x8 	U x16  Φ3x16	

Important information:

Check all the components and screws before assembly. Please don't hesitate to contact us if the package you received is missing parts or screws.

Wichtiger Hinweis:

Bestätigen Sie bitte alle Komponenten und Schrauben vor der Montage. Bitte wenden Sie sich an uns, falls etwa Teile oder Schrauben im Paket fehlt ist.



Bitte keinen elektrischen
Schrauber verwenden!

Please do not use an electric screwdriver.
Bitte keinen elektrischen Schrauber verwenden.

Schritt 1

H



Φ8x30

36

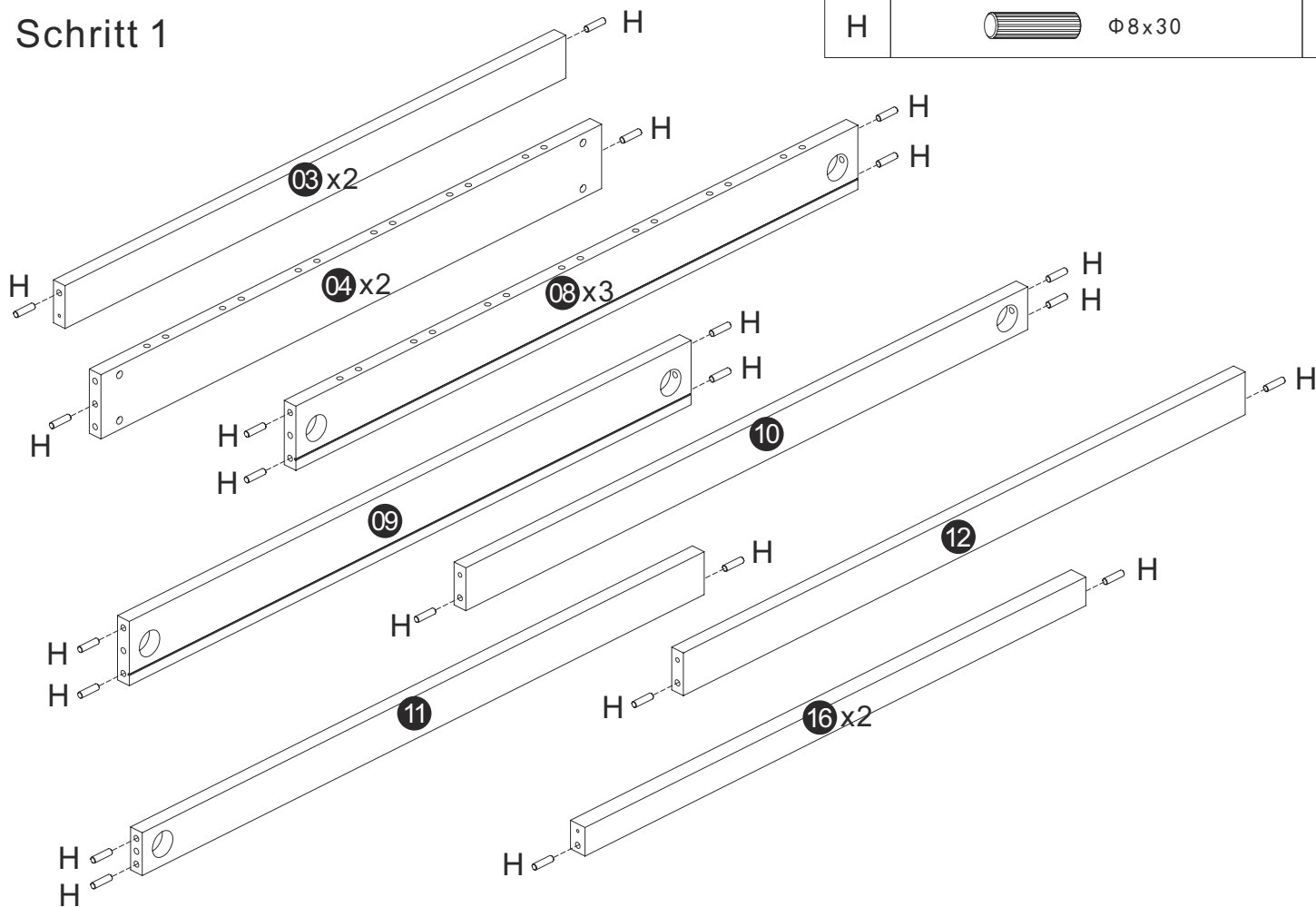

Schritt 2

H



Φ8x30

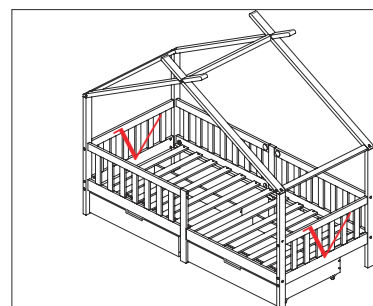
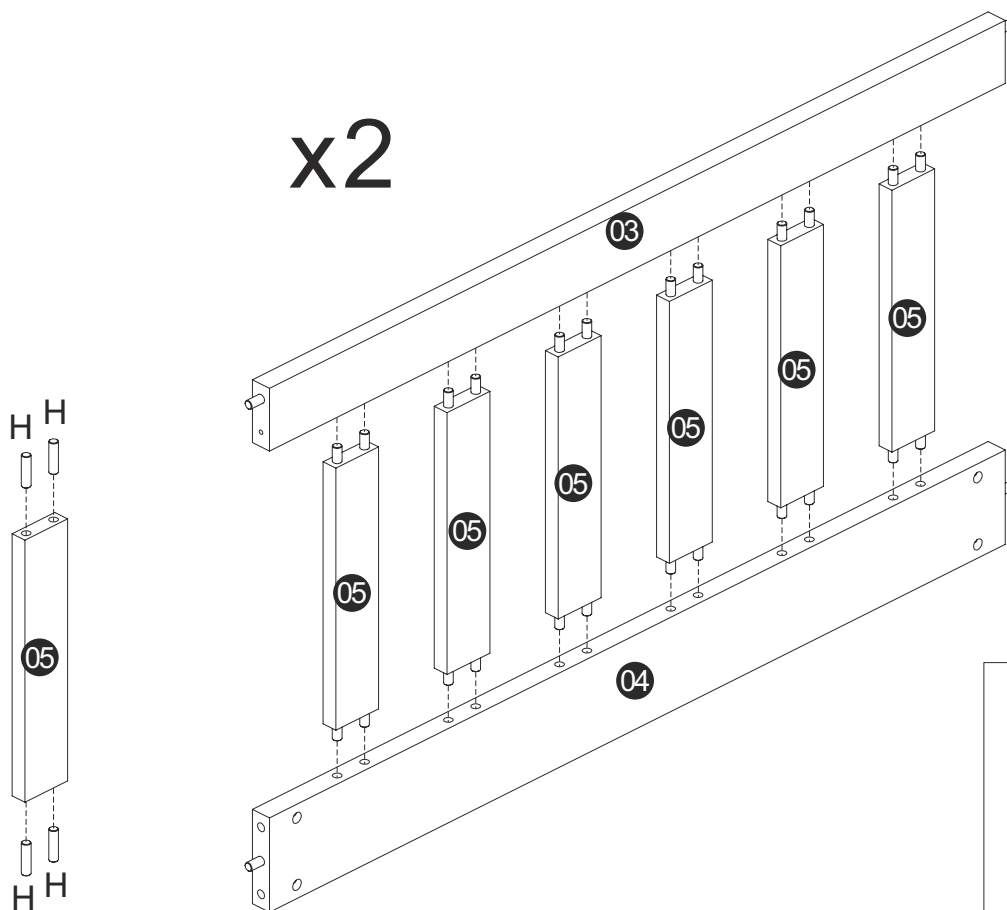

48

x2



Schritt 3

x2

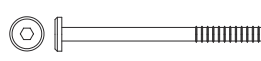
A		8
B		8
C		4

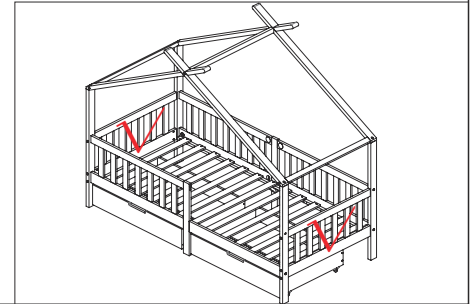
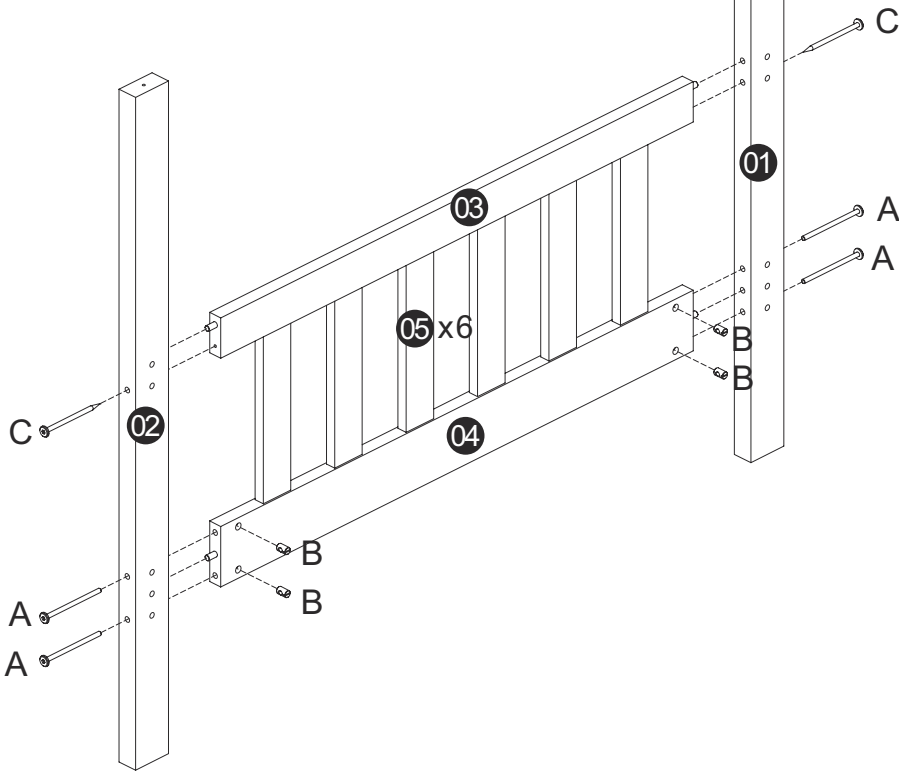

Schritt 4

H		28
---	---	----

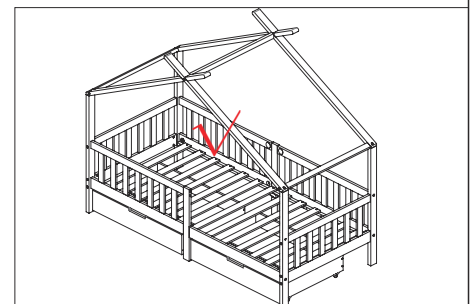
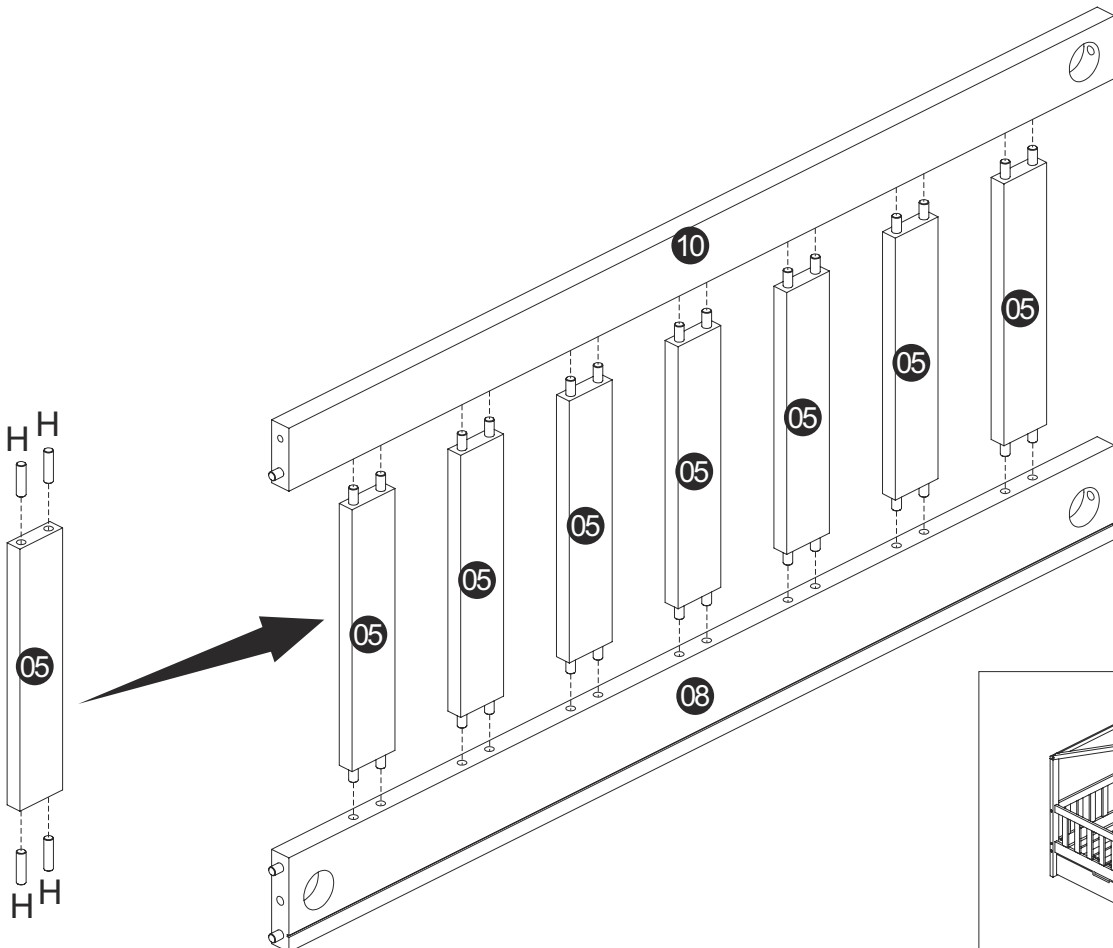

Schritt 5

H



Φ8x30

28

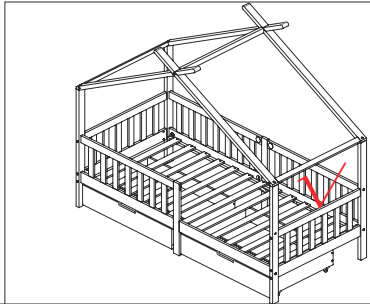
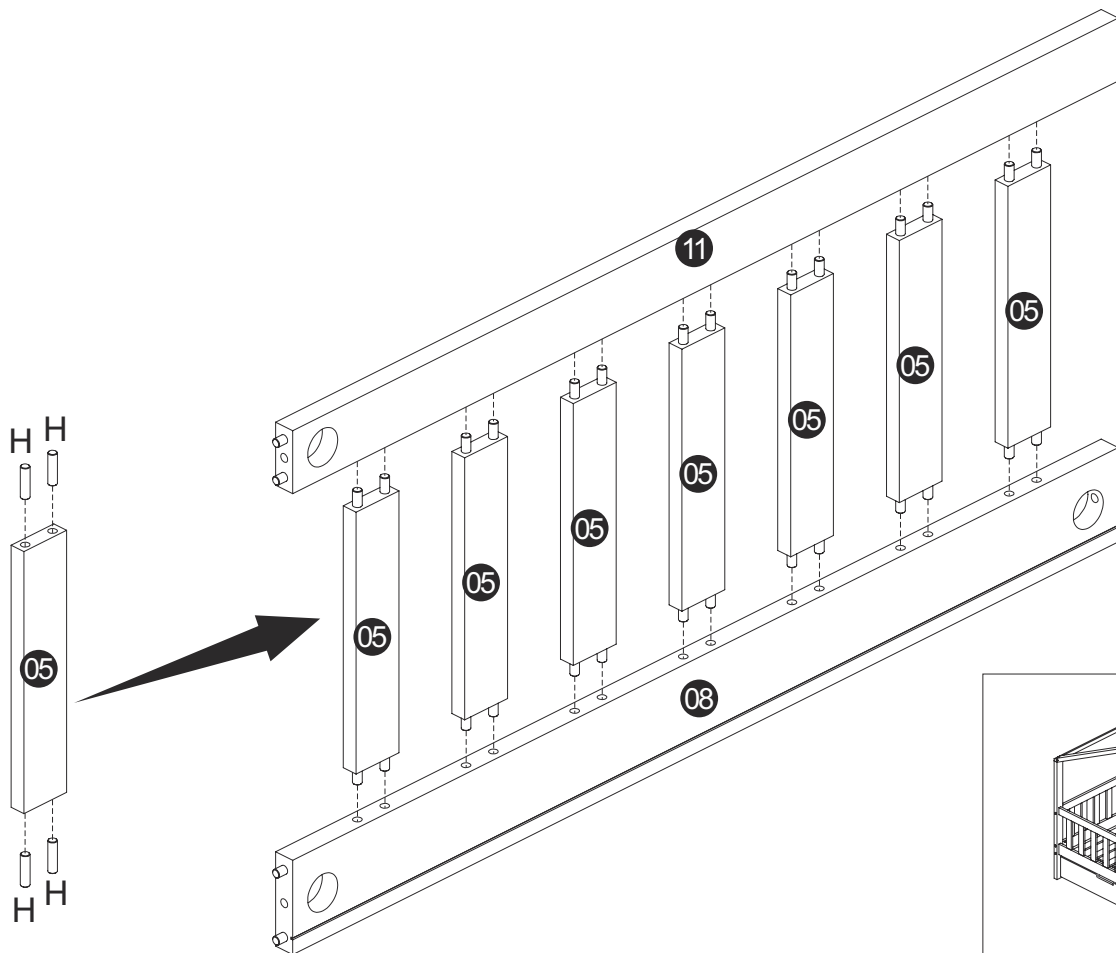

Schritt 6

F



2

G



4

K



1

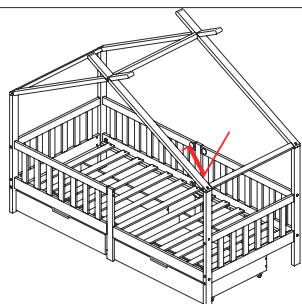
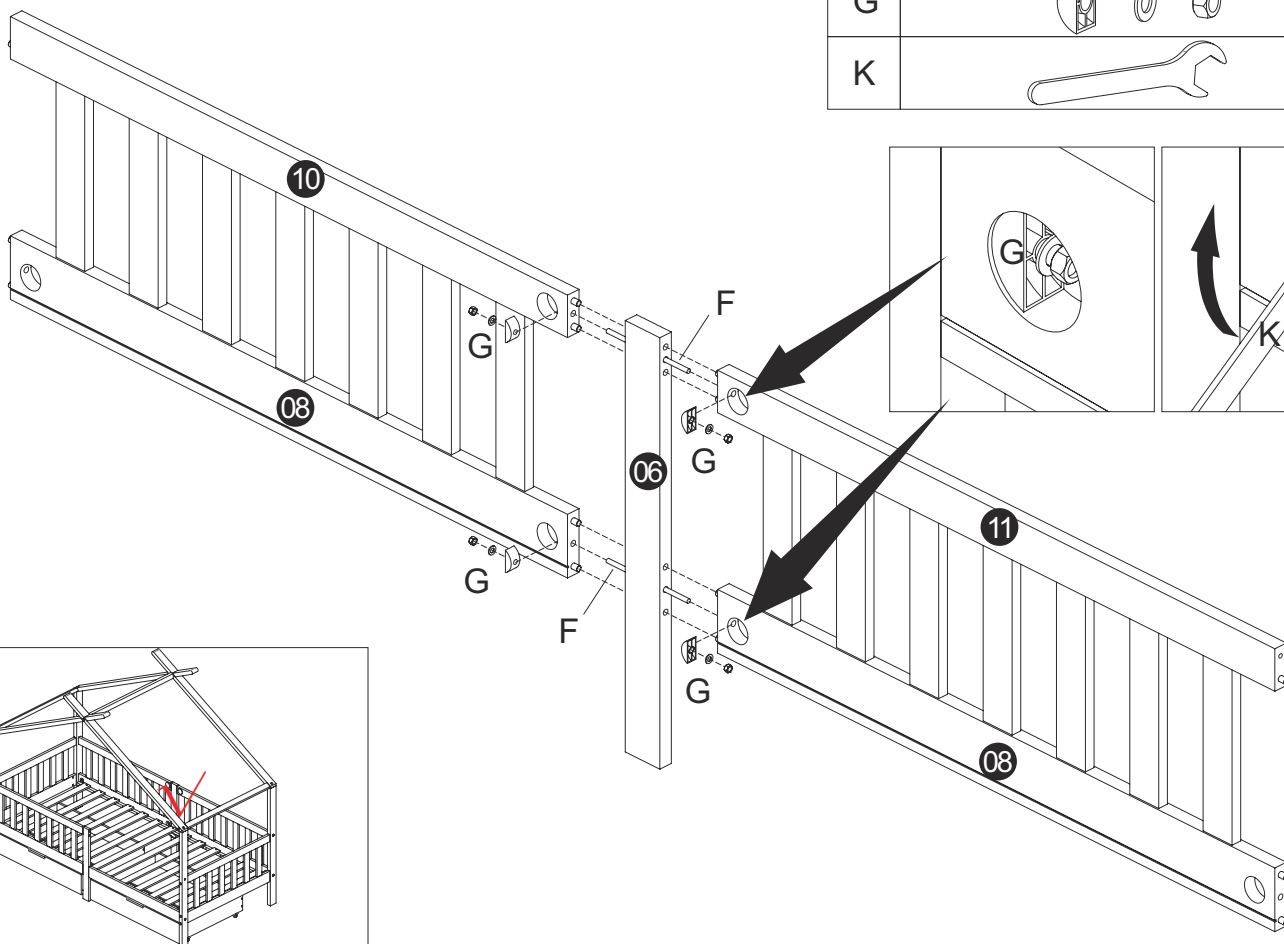

Schritt 7

J



Φ4x30

15

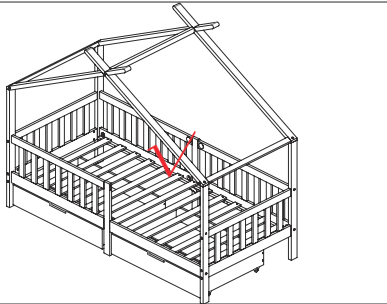
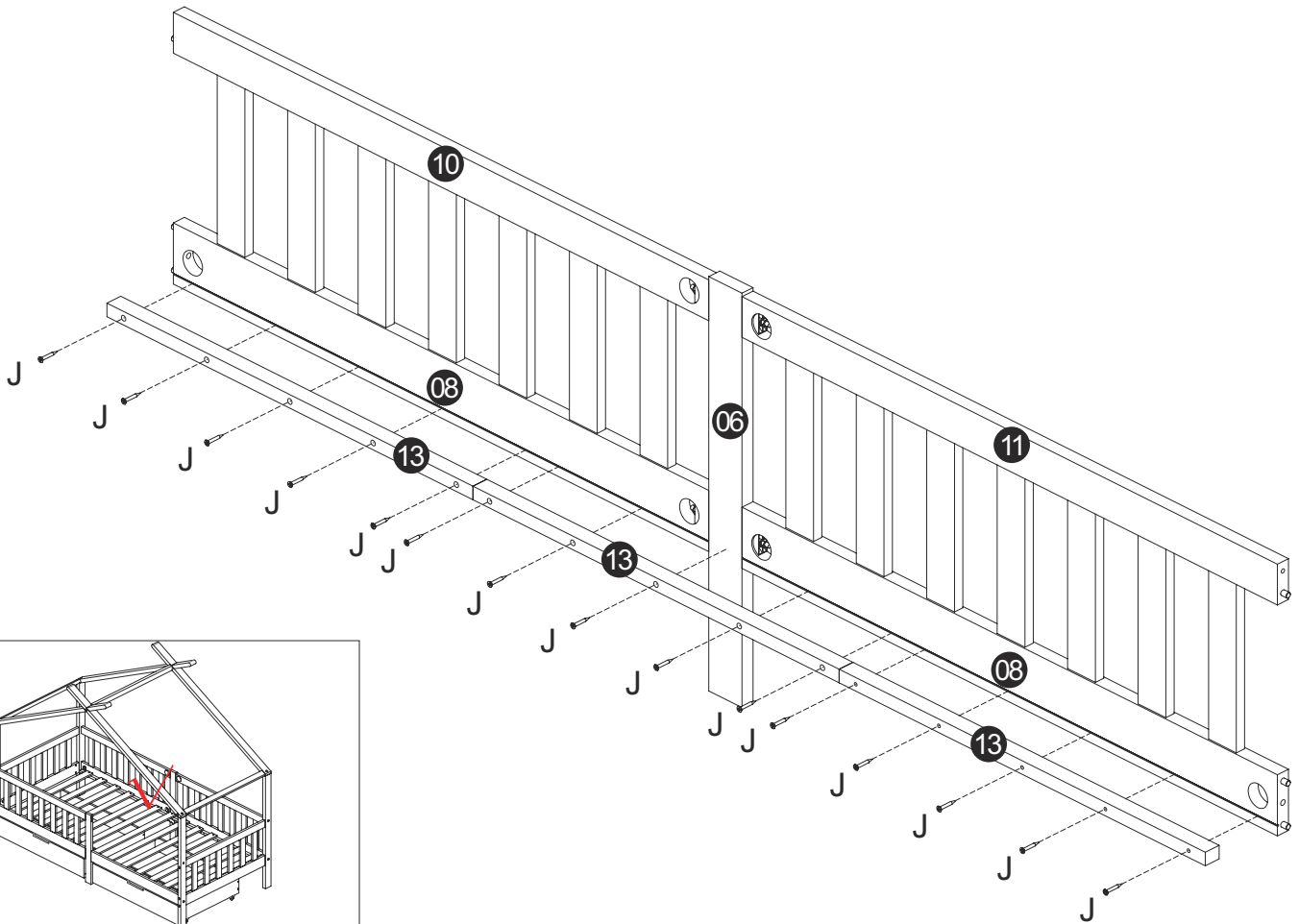

Schritt 8

H



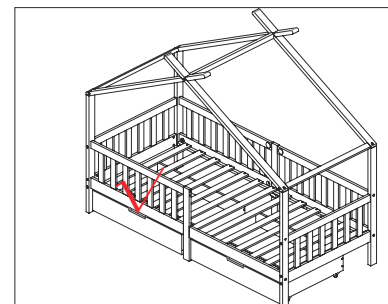
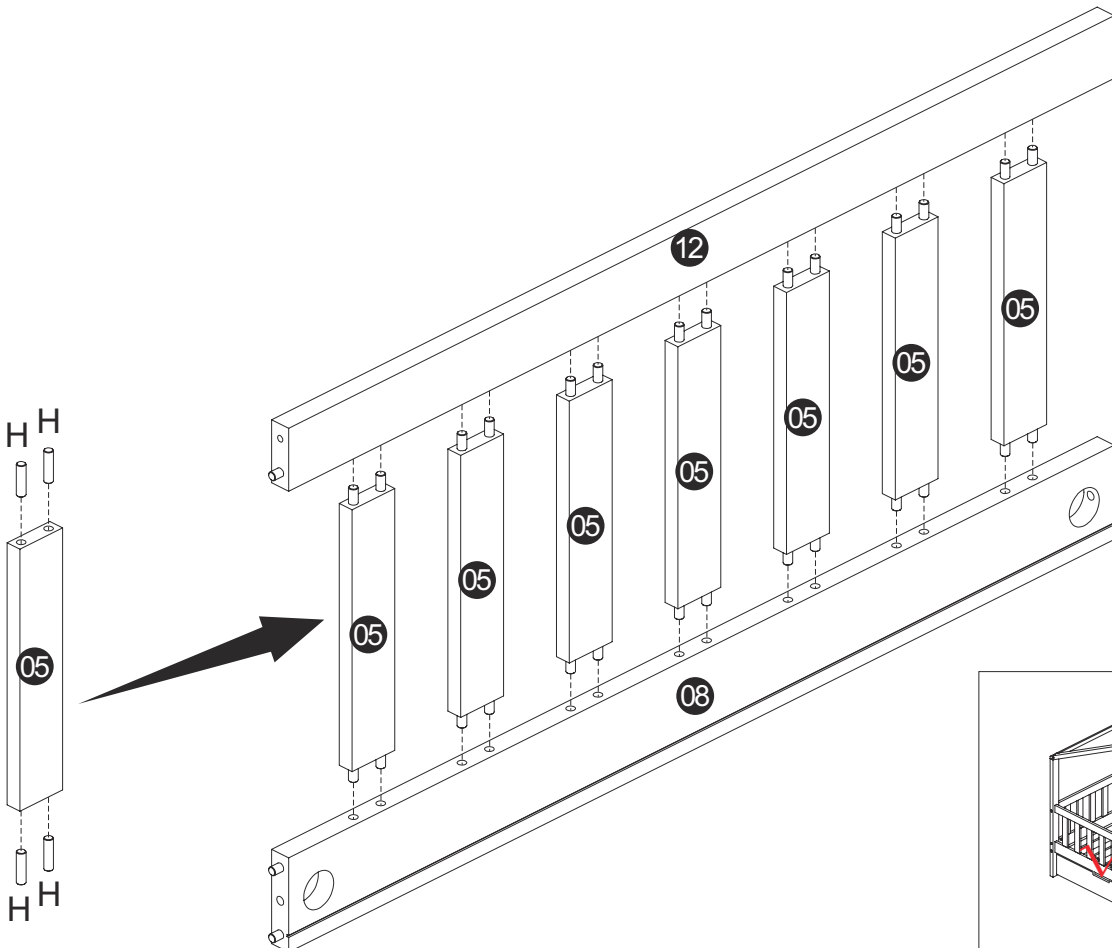

Φ8x30

28



Schritt 9

C		1
---	--	---

F		1
---	--	---

G		2
---	---	---

K		1
---	---	---

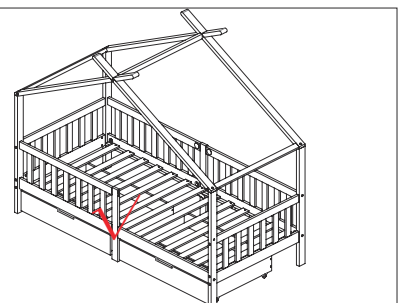
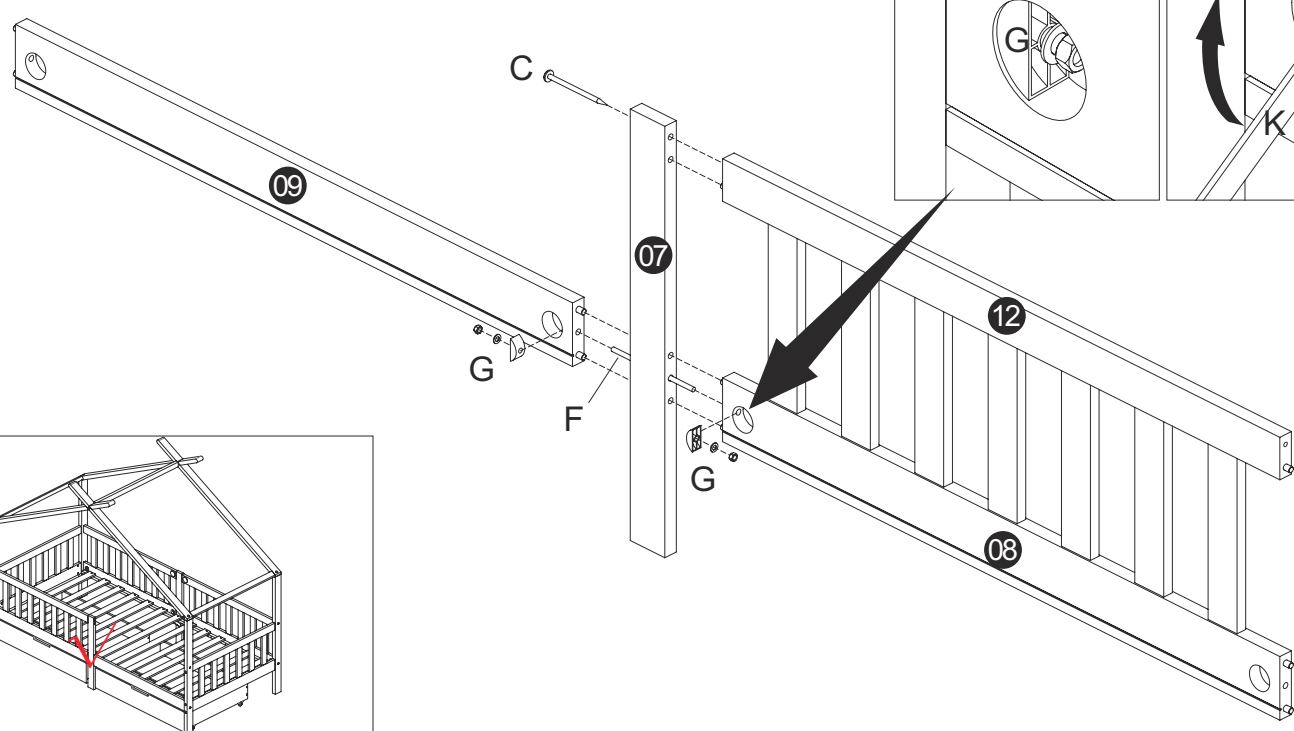
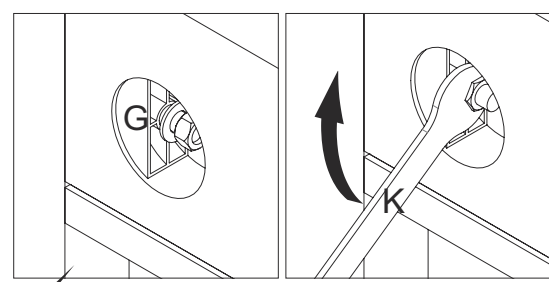

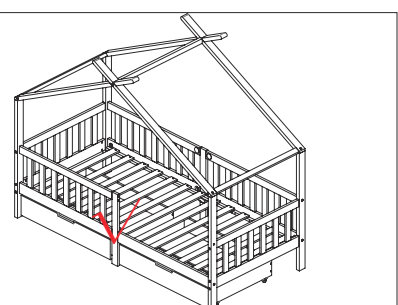
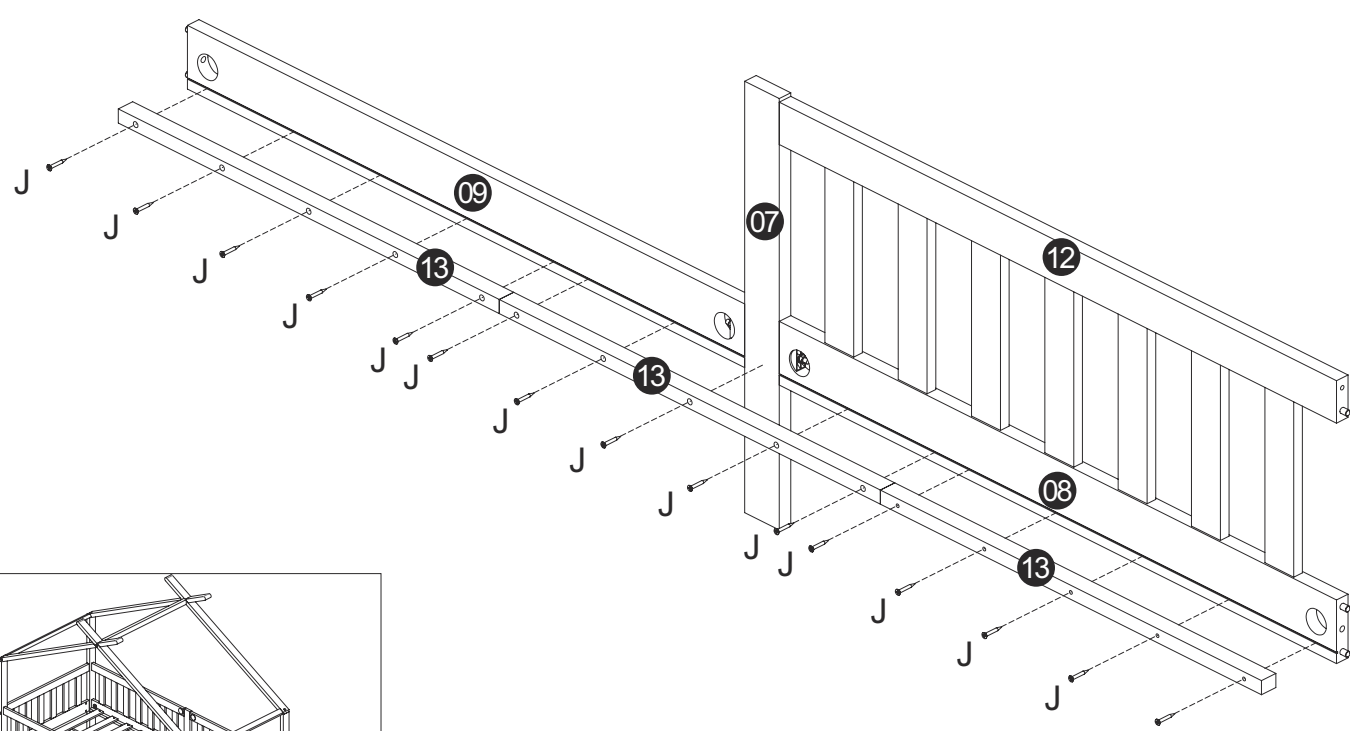

Schritt 10

J		15
---	---	----

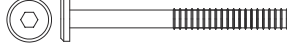
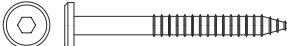

Schritt 11

D		M6x80	4
E		Φ6x80	3
G			4
K			1

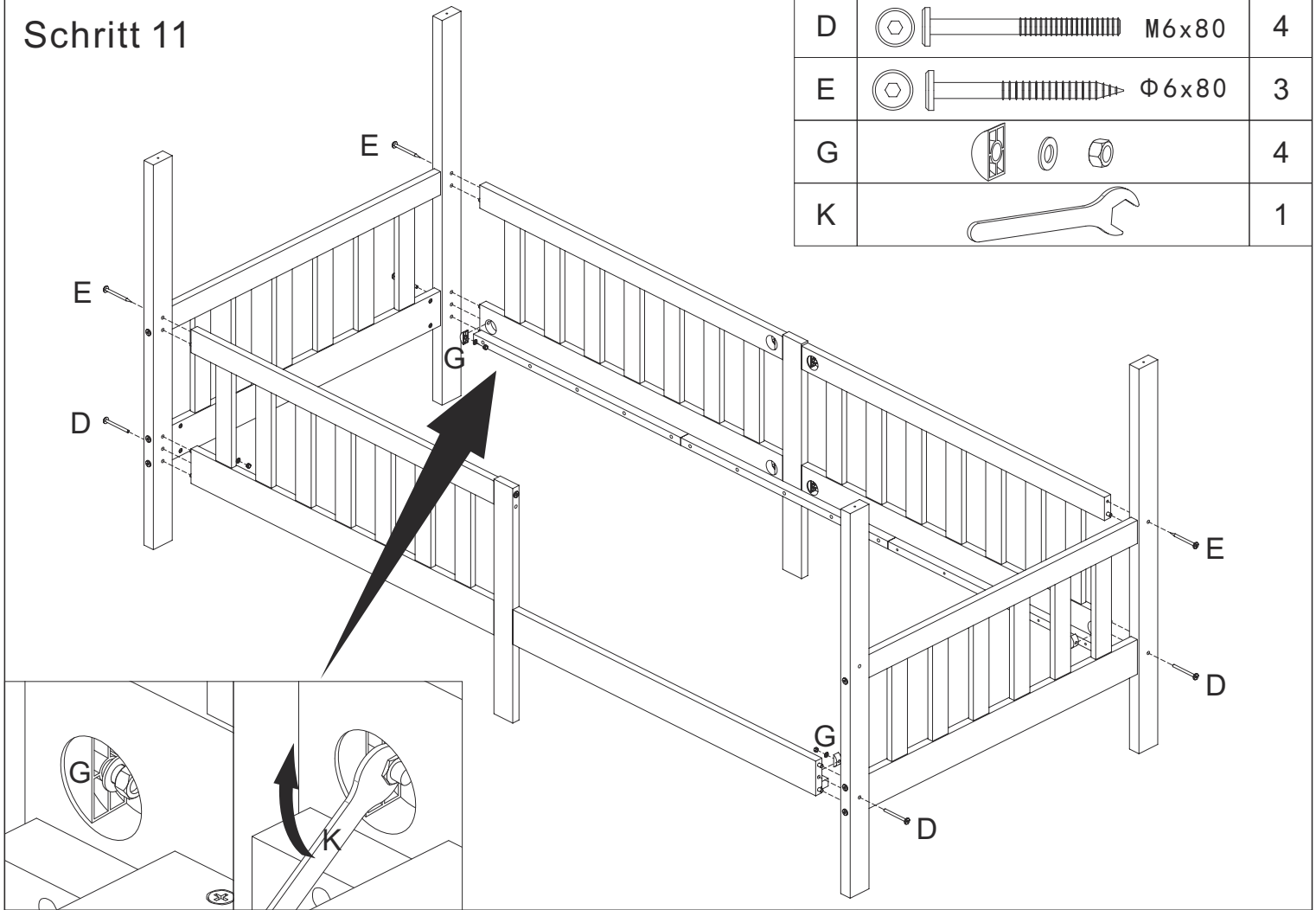

Schritt 12

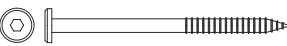
C		Φ6x100	6
---	---	--------	---

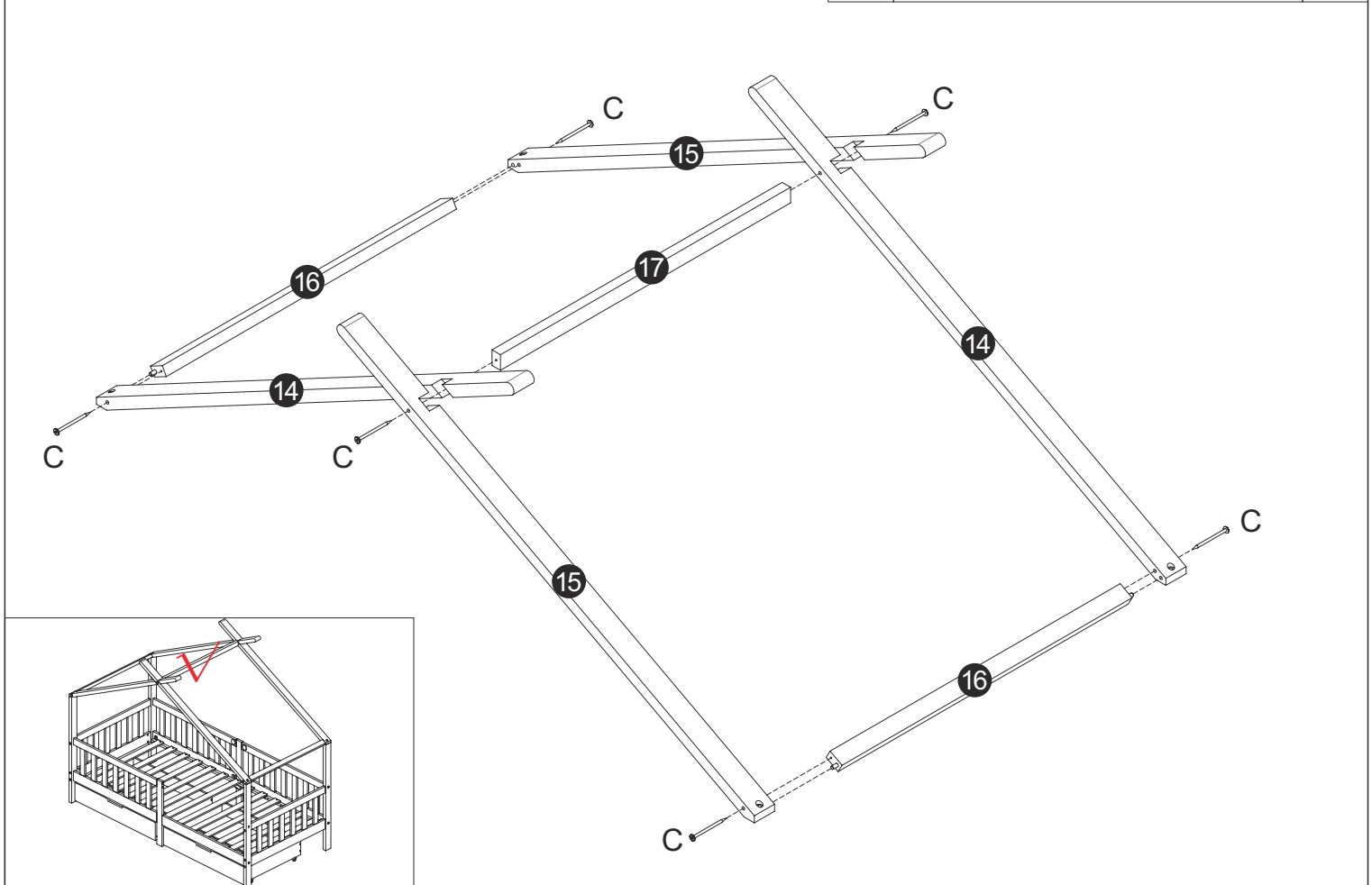

Schritt 13

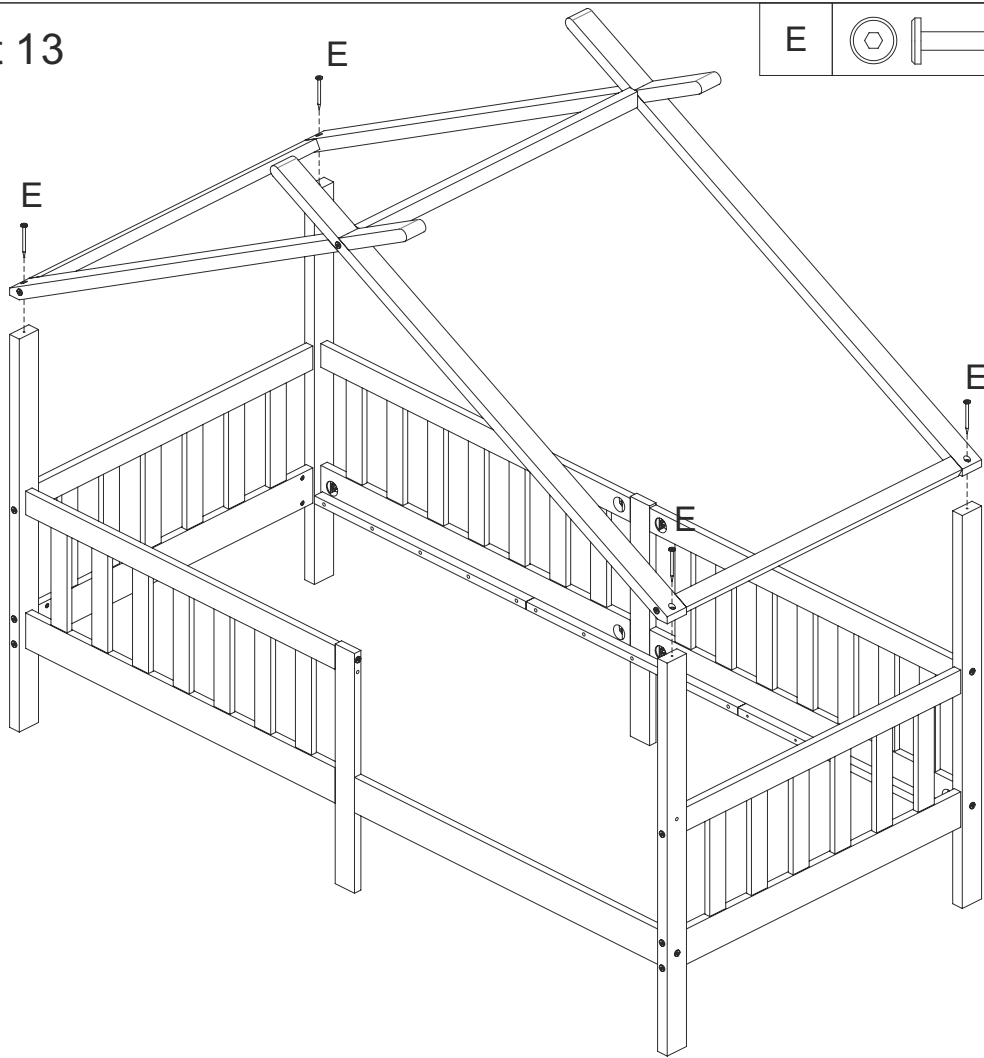

E



Φ6x80

4

Schritt 14

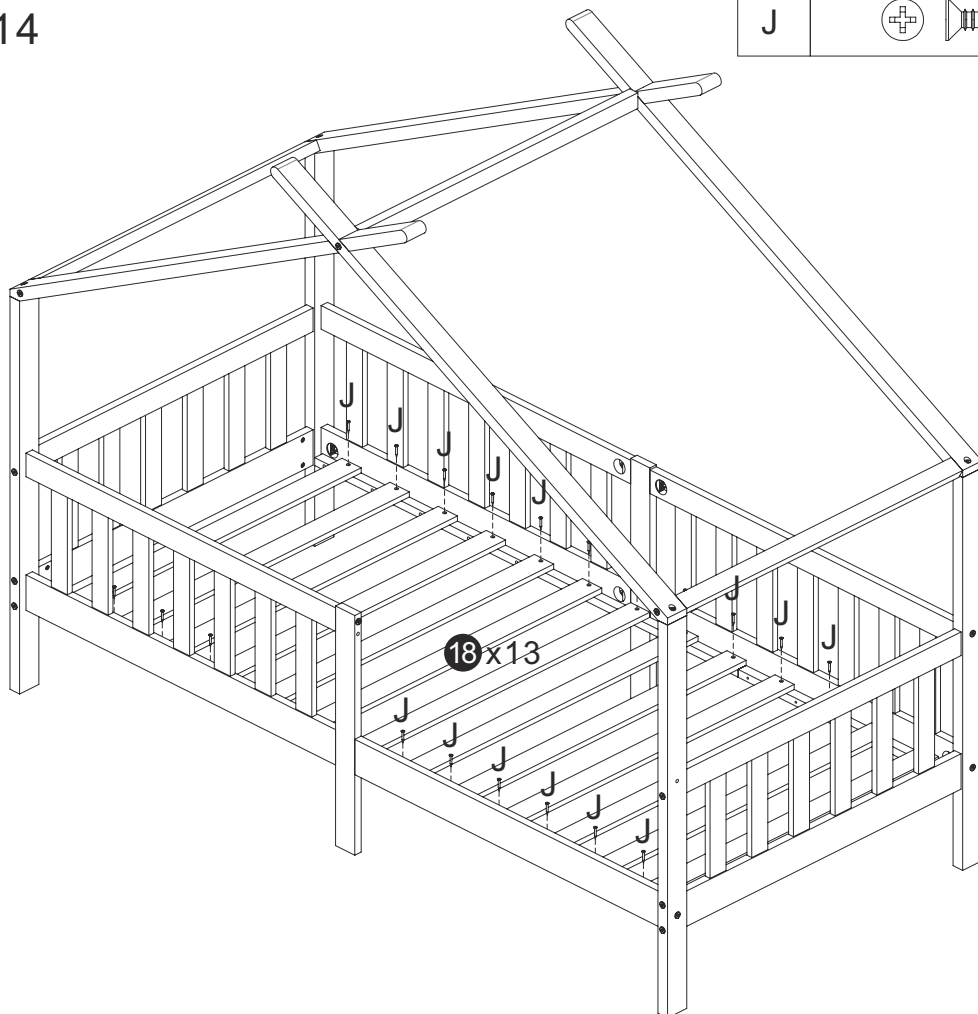

J



Φ4x30

26

18x13

Schritt 15

J



Φ4x30

4

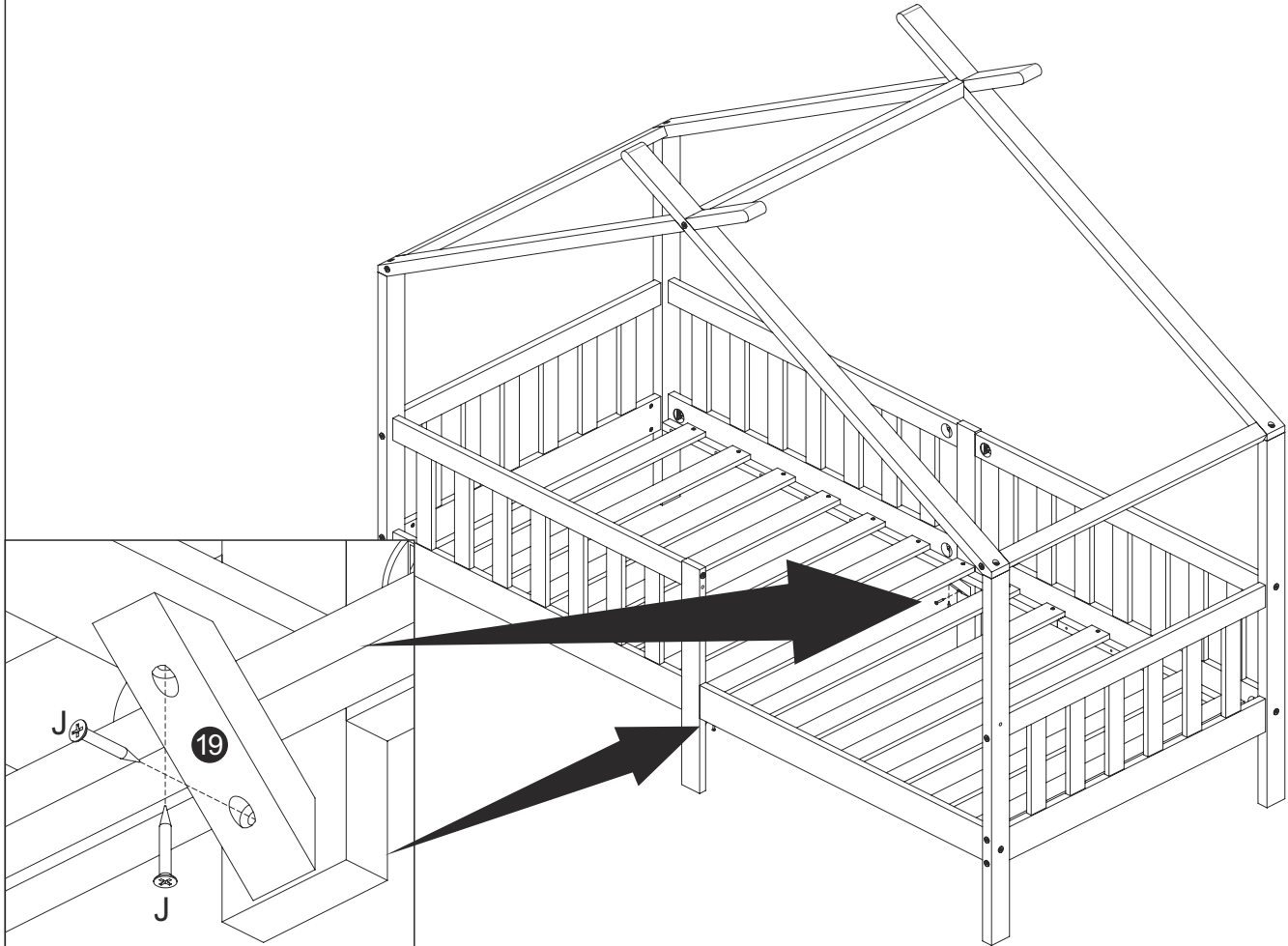

Schritt 16

M



4

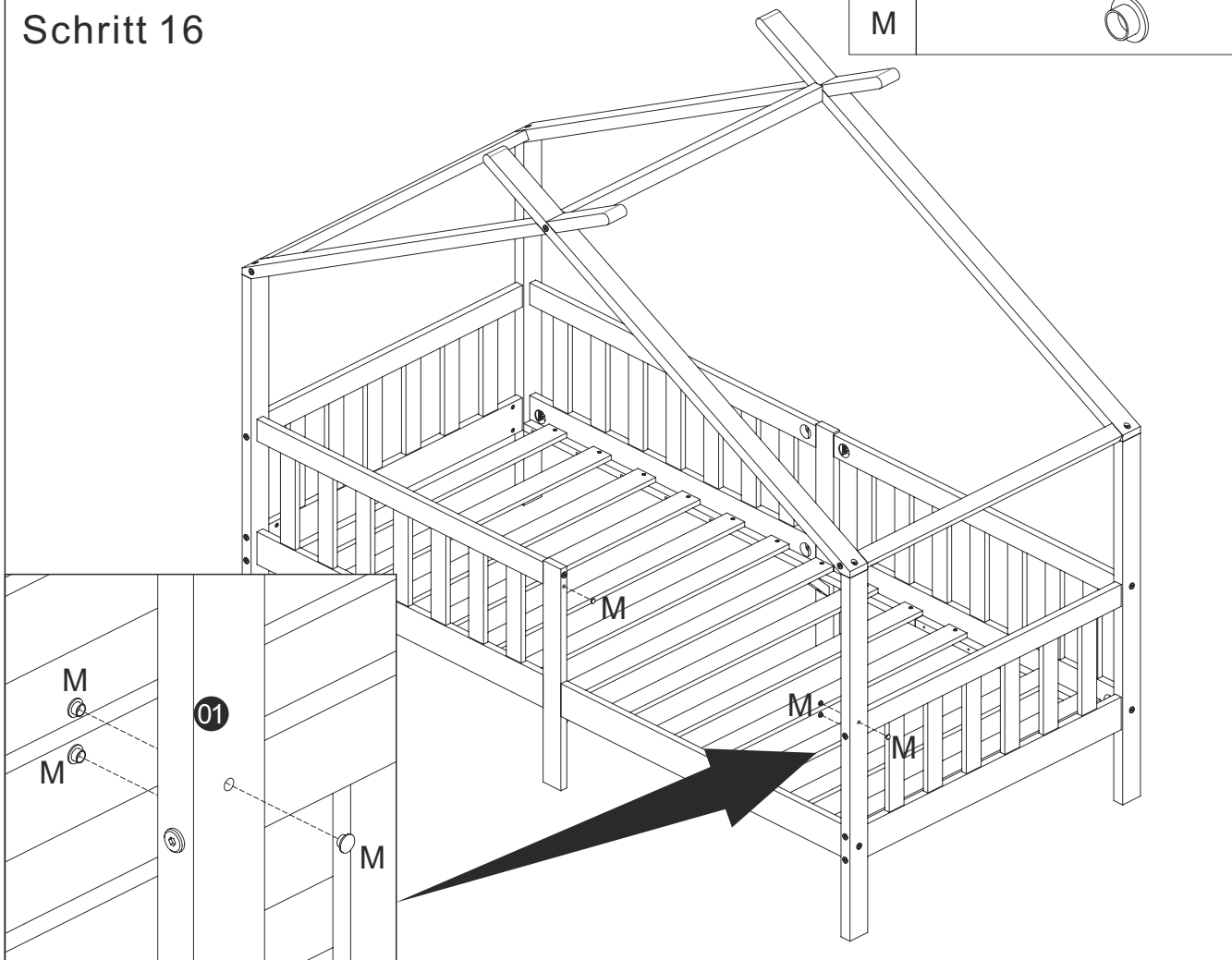

Schritt 17

N

2

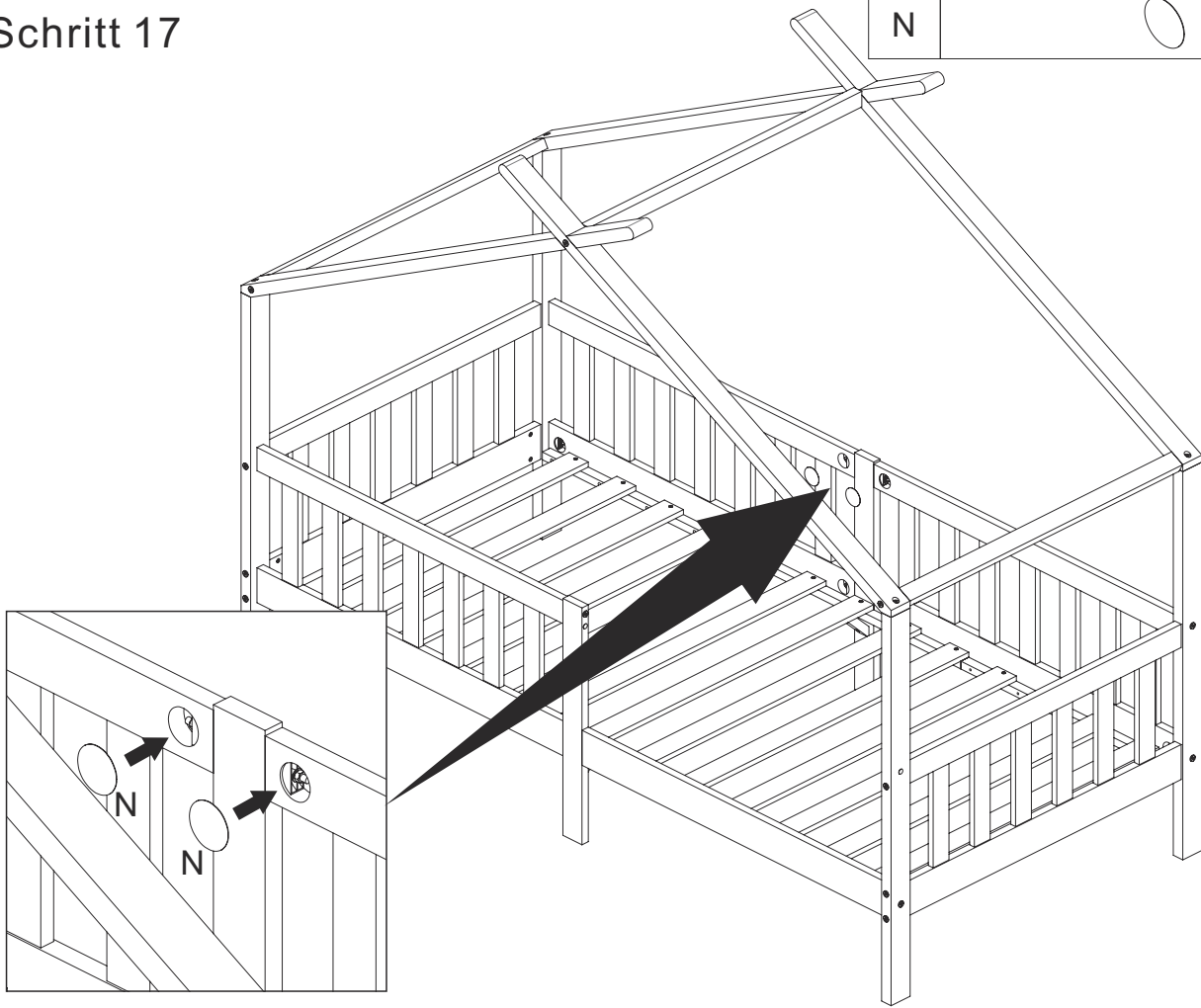

Schritt 18

H

 $\Phi 8 \times 30$

8

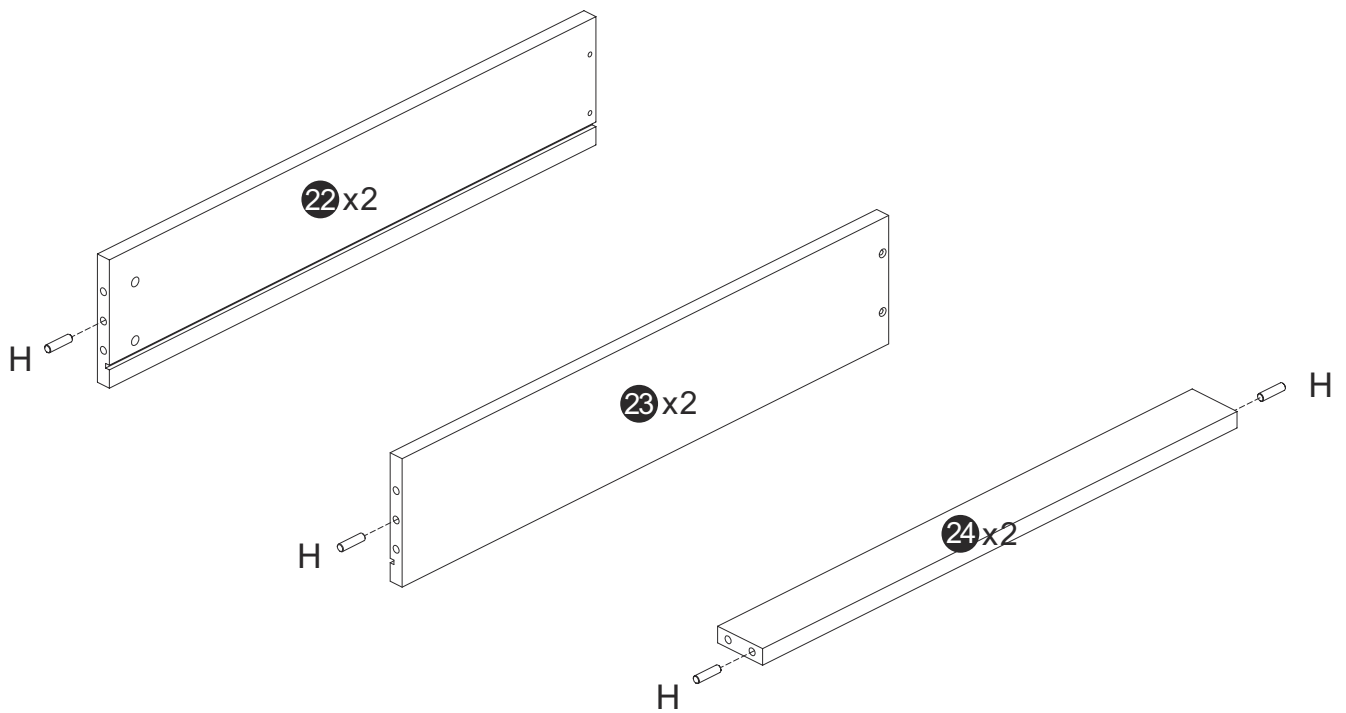

Schritt 19

P



12

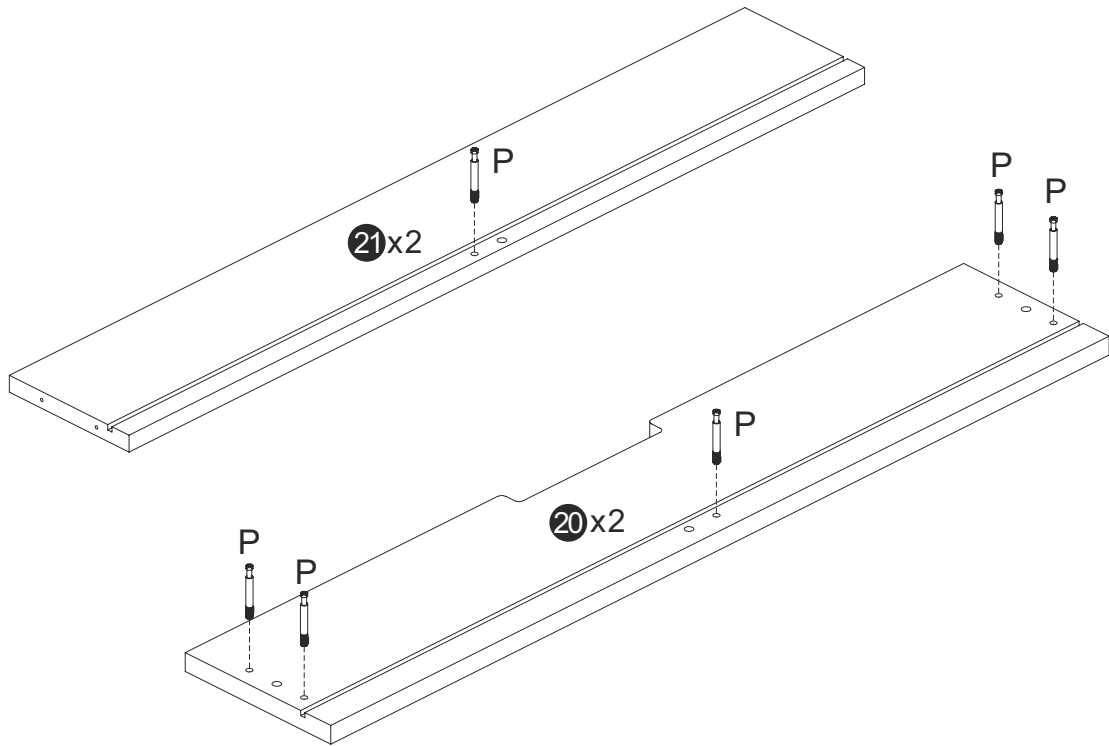

Schritt 20

Q



Φ4x40

8

x2

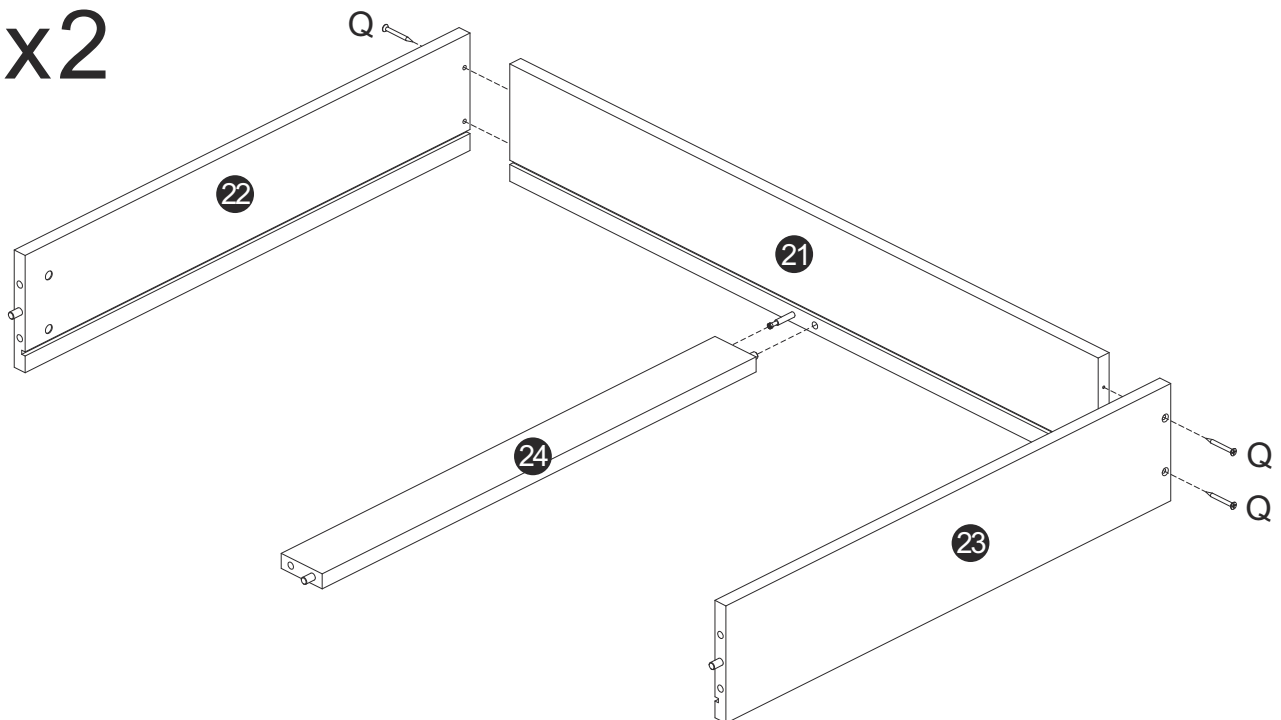

Schritt 21

R



2

x2

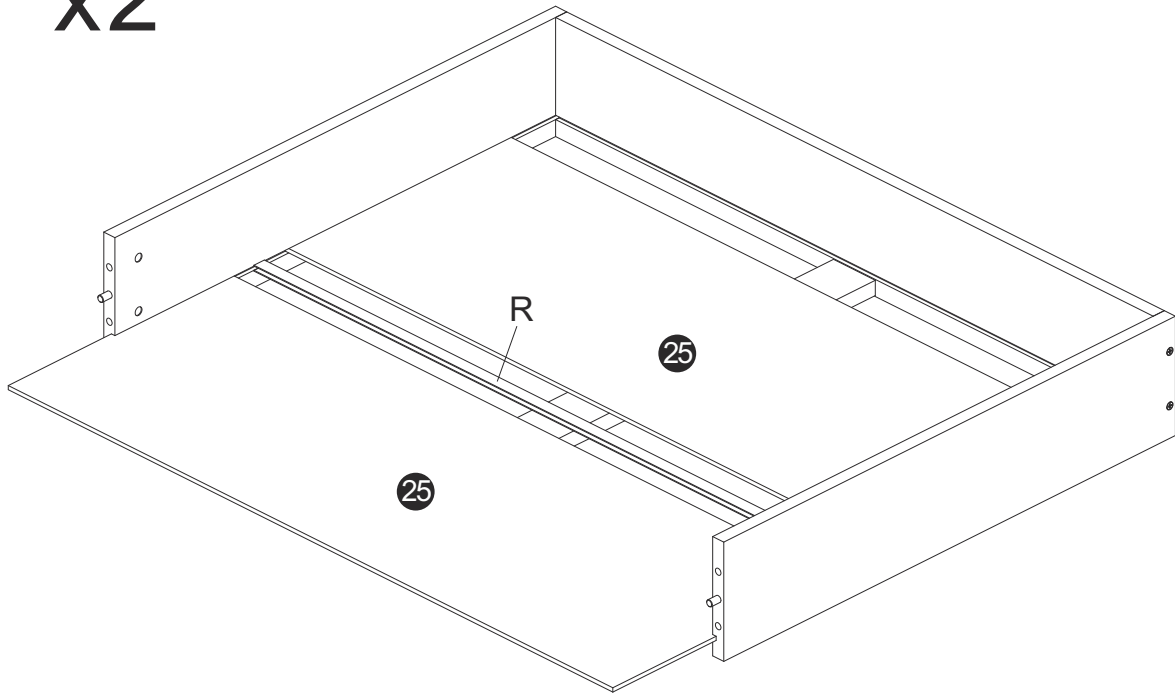

Schritt 22

S



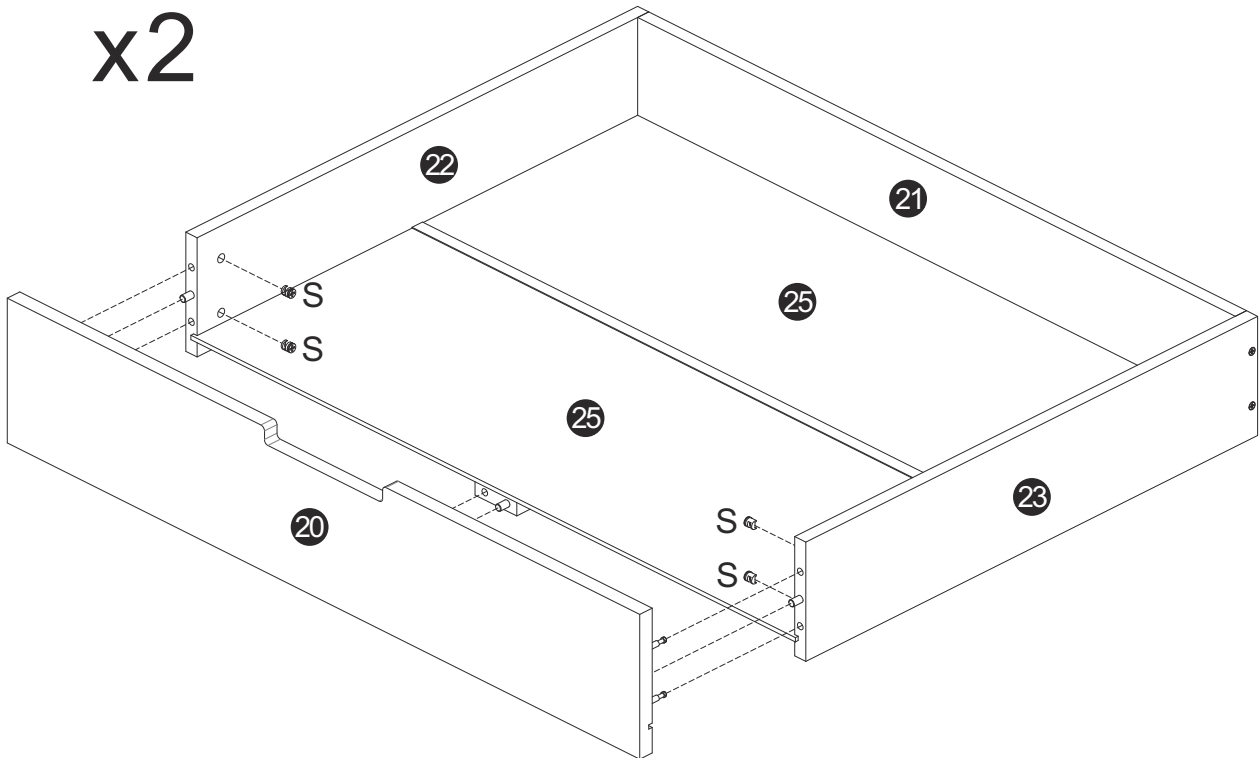

8

x2



Schritt 23

x2

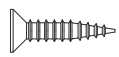
S		4
T		8
U	  $\Phi 3 \times 16$	16

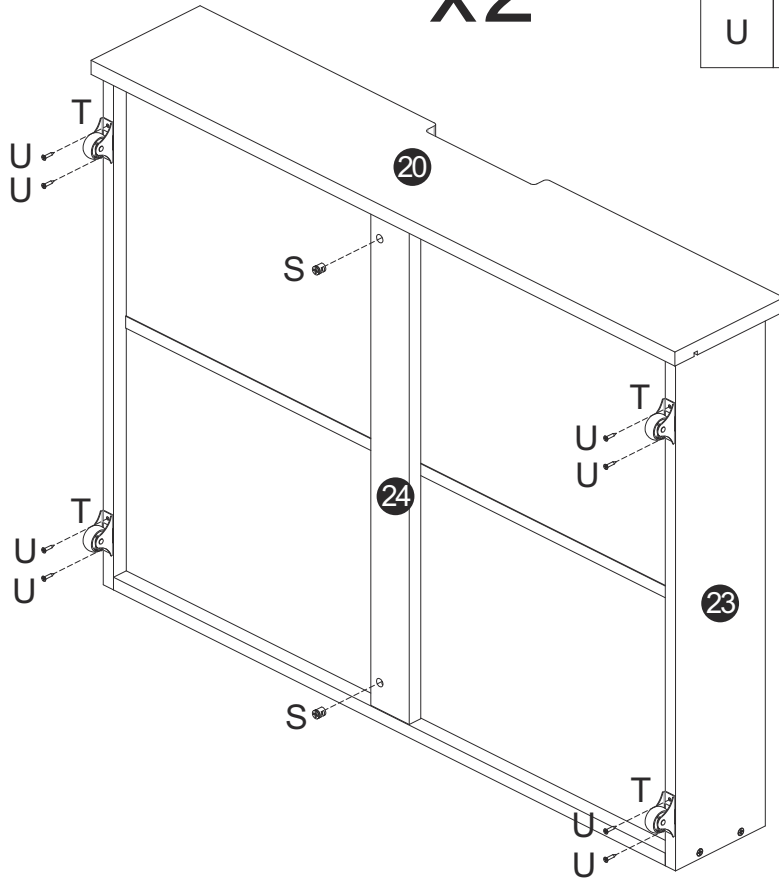

Schritt 24

