

# CHiQ

## Freezer

MODEL:FSD166NE4E

CLIMATE CLASS	SN/N/ST
RATED VOLTAGE	220-240V~
RATED CURRENT	0.5A
RATED FREQUENCY	50HZ
Defrosting Power	165W
ENERGY CONSUMPTION OF E <sub>16</sub>	0.359kWh/24h
ENERGY CONSUMPTION OF E <sub>32</sub>	0.671kWh/24h
FREEZER STORAGE VOLUME	166L
INSULATION BLOWING GAS	Cyclopentane
CLASS OF PROTECTION AGAINST ELECTRIC SHOCK	Class I
REFRIGERANT/AMOUNT	R600a/43g
FREEZING CAPACITY	7.5kg/24h
TEMPERATURE RISE TIME	8h
NET WEIGHT	46Kg
PRODUCT DIMENSIONS(W*D*H)	540x641x1440mm

Diagram of Circuit Principles

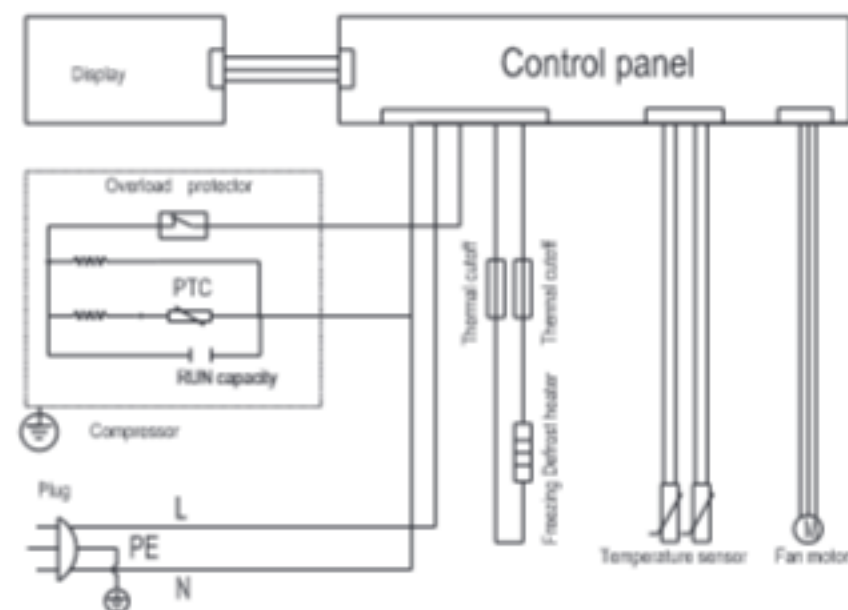

Made in PRC

Serial Number:



68 mm

98 mm