

Montageanleitung | Instructions de montage Assembly Instructions | Instrucciones de montaje

SKU NUMBER: N616P189651/N616P189652
N616P189653/N616P189654
N616P189655/N616P189656

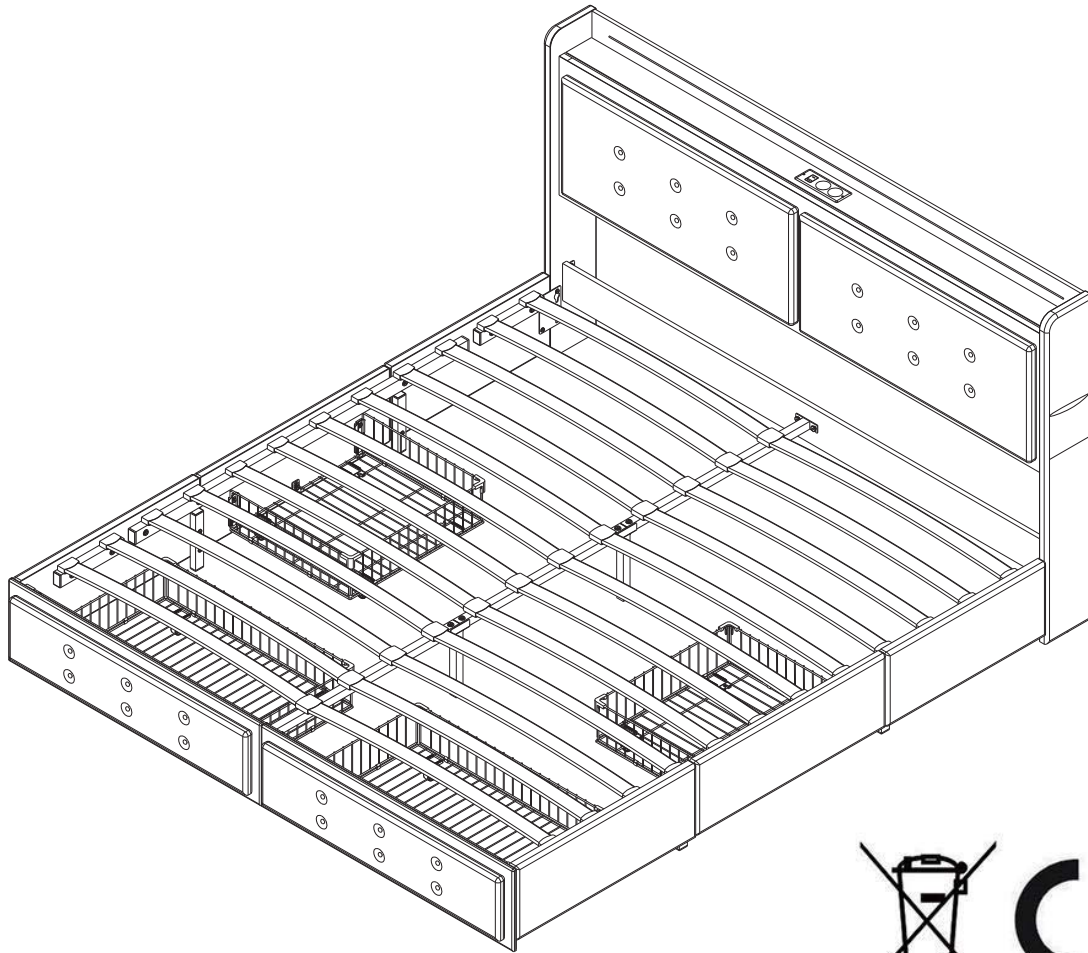

GB This set comes in 2 boxes. If you do not receive a full set of 2 boxes, please contact our customer service.

DE Dieses Set wird in 2 Schachteln geliefert. Wenn Sie nicht ein komplettes Set von 2 Boxen erhalten, kontaktieren Sie bitte unseren Kundenservice.

FR Ce set est livré en 2 boîtes. Si vous ne recevez pas un jeu complet de 2 boîtes, veuillez contacter notre service clientèle.

English

IMPORTANT ! KEEP FOR FUTURE REFERENCE : READ CAREFULLY

- To be assembled by an adult. Assembly must be checked by an adult before use
- WARNING ! Keep all screws, small parts and plastic bags out of the reach of children
- Properly identify all parts before assembling
- Never use your item if any of its parts are broken or missing
- Should any problems arise, please contact our After Sales Service
- Manufacturer's instructions shall be followed at all times
- Care: Clean with a soft, dry cloth. In case of larger stains, carefully rub with a slightly damp, non-abrasive sponge
- Avoid the risk of fire by not placing furniture near sources of ignition or hot items
- Do not jump on the bed

Deutsch

WICHTIG ! ZUM SPÄTEREN NACHSCHLAGEN AUFBEWAHREN: SORGFÄLTIG LESEN

- Muss von einem Erwachsenen zusammengebaut werden. Der Zusammenbau muss vor dem Gebrauch von einem Erwachsenen überprüft werden
- WARNUNG! Bewahren Sie alle Schrauben, Kleinteile und Plastikbeutel außerhalb der Reichweite von Kindern auf
- Kennzeichnen Sie vor dem Zusammenbau alle Teile richtig
- Benutzen Sie Ihren Artikel niemals, wenn Teile gebrochen sind oder fehlen
- Sollten Probleme auftreten, wenden Sie sich bitte an unseren Kundendienst
- Die Anweisungen des Herstellers sind stets zu befolgen
- Pflege: Mit einem weichen, trockenen Tuch reinigen. Bei größeren Flecken vorsichtig mit einem leicht feuchten, nicht scheuernden Schwamm abreiben. nicht scheuernden Schwamm
- Vermeiden Sie die Gefahr eines Brandes, indem Sie die Möbel nicht in der Nähe von Zündquellen oder heißen Gegenständen aufstellen
- Nicht auf das Bett springen

Français

IMPORTANT ! CONSERVER POUR RÉFÉRENCE ULTÉRIEURE : LIRE ATTENTIVEMENT

- Le montage doit être effectué par un adulte. Le montage doit être vérifié par un adulte avant Utilisation
- ATTENTION ! Tenir les vis, les petites pièces et les sachets en plastique hors de portée des enfants
- Identifiez correctement toutes les pièces avant de les assembler
- N'utilisez jamais votre article si l'une de ses pièces est cassée ou manquante
- En cas de problème, veuillez contacter notre service après-vente
- Les instructions du fabricant doivent être respectées à tout moment
- Entretien : nettoyer avec un chiffon doux et sec. En cas de taches plus importantes, frotter soigneusement avec une éponge non abrasive légèrement humide. légèrement humide et non Abrasive
- Évitez les risques d'incendie en ne plaçant pas les meubles à proximité de sources d'inflammation ou d'objets chauds
- Ne pas sauter sur le lit

Italiano

IMPORTANTE! CONSERVARE PER RIFERIMENTO FUTURO: LEGGERE ATTENTAMENTE

- Deve essere assemblato da un adulto. L'assemblaggio deve essere controllato da un adulto prima dell'uso
- **ATTENZIONE!** Tenere tutte le viti, le piccole parti e i sacchetti di plastica fuori dalla portata dei bambini
- Identificare correttamente tutte le parti prima dell'assemblaggio
- Non utilizzare mai l'articolo se alcune parti sono rotte o mancanti
- In caso di problemi, si prega di contattare il nostro Servizio Post Vendita
- Le istruzioni del produttore devono essere sempre seguite
- Cura: Pulire con un panno morbido e asciutto. In caso di macchie più estese, strofinare accuratamente con una spugna leggermente umida e nonspugna leggermente umida e non abrasiva
- Evitare il rischio di incendio, non collocando i mobili vicino a fonti di accensione o a oggetti caldi
- Non saltare sul letto

Español

¡ IMPORTANTE ! CONSERVELO PARA FUTURAS CONSULTAS: LEA ATENTAMENTE



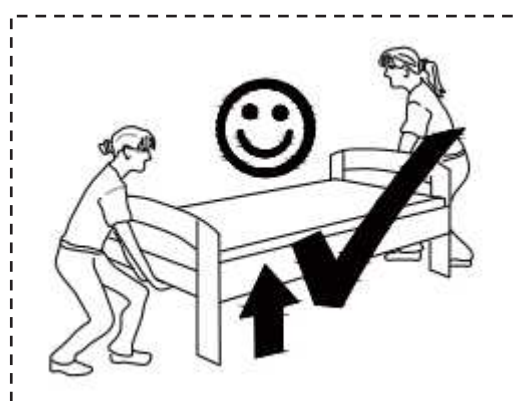
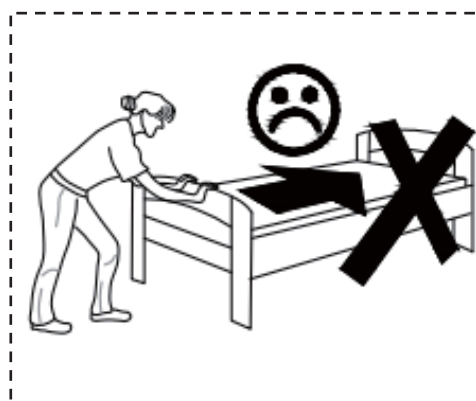

- Debe ser montado por un adulto. El montaje debe ser comprobado por un adulto antes del uso
- ADVERTENCIA Mantenga todos los tornillos, piezas pequeñas y bolsas de plástico fuera del alcance de los niños.
- Identifique correctamente todas las piezas antes de montarlas
 - Nunca utilice su artículo si alguna de sus piezas está rota o falta
 - Si surge algún problema, póngase en contacto con nuestro Servicio Postventa
 - Las instrucciones del fabricante deben seguirse en todo momento
 - Cuidado: Limpiar con un paño suave y seco. En caso de manchas más grandes, frote cuidadosamente con una esponja no abrasiva ligeramente humedecida.
 - Evite el riesgo de incendio no colocando los muebles cerca de fuentes de ignición u objetos calientes.
 - No saltar sobre la cama.

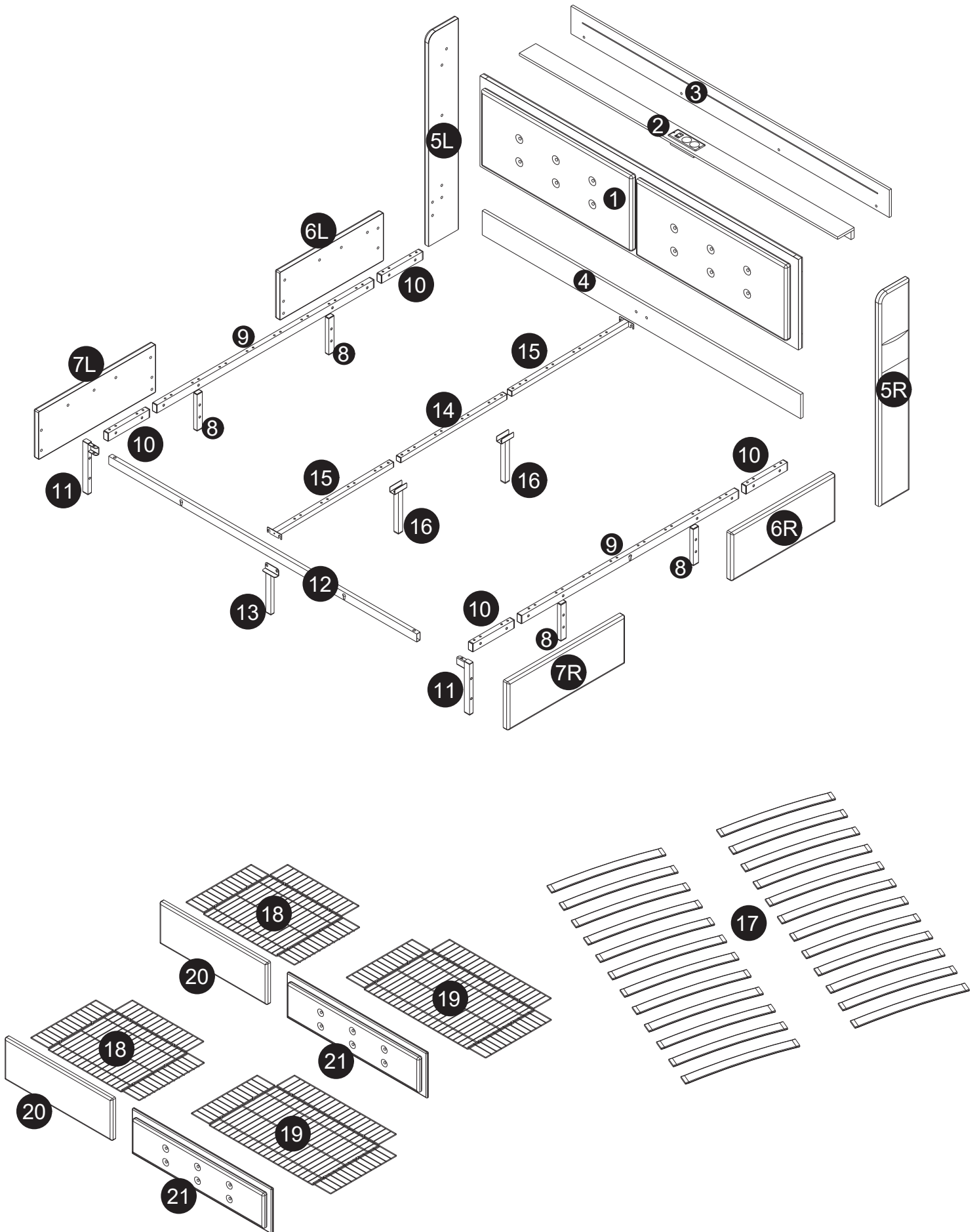

Stückliste

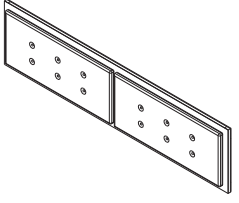

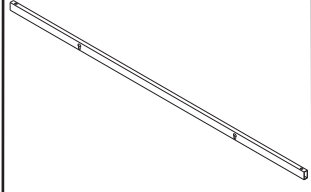
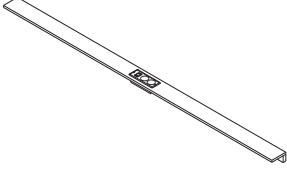
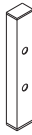
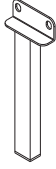
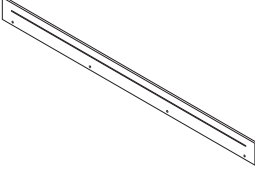
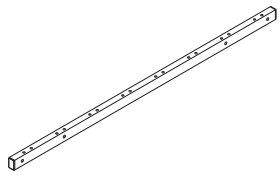
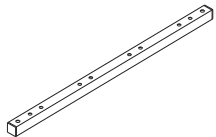
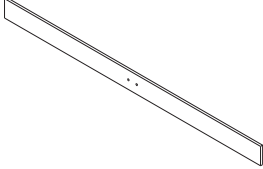
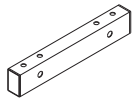
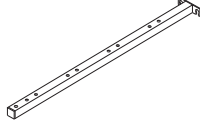
N616P189651/N616P189653/N616P189655

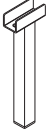

1		X1	5R		X1	12		X1
2		X1	8		X4	13		X1
3		X1	9		X2	14		X1
4		X1	10		X4	15		X2
5L		X1	11		X2	16		X2

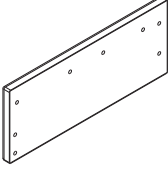
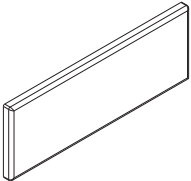
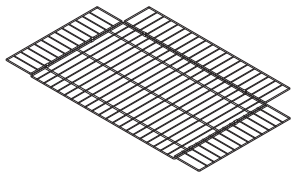
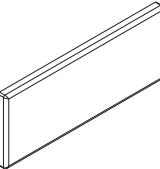
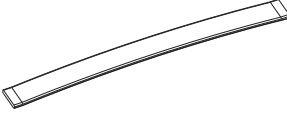
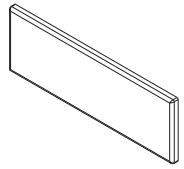
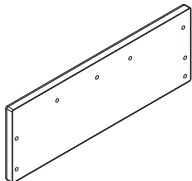
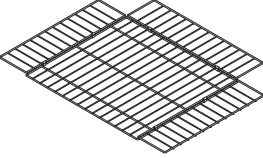
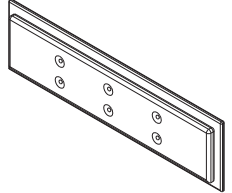
N616P189652/N616P189654/N616P189656

6L		X1	7R		X1	19		X2
6R		X1	17		X24	20		X2
7L		X1	18		X2	21		X2



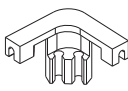

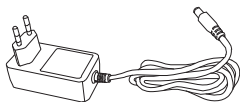
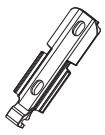
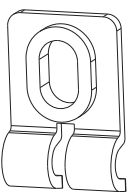
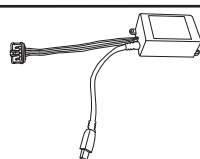
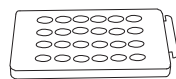
Hardware List-Hardware-Liste-Liste du matériel

N616P189651/N616P189653/N616P189655

T		X8	V		X16	X		X1
U		X8	W		X4	Y		X1
						Z		X1

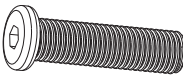
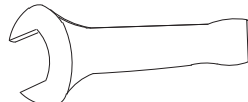
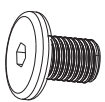
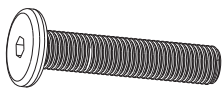
Hardware List-Hardware-Liste-Liste du matériel

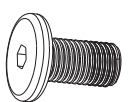
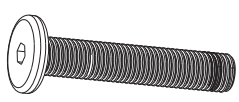
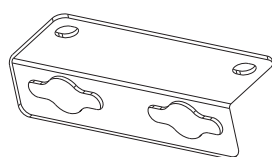
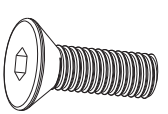
N616P189652/N616P189654/N616P189656

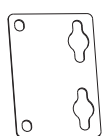
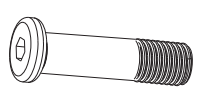
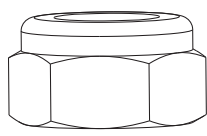
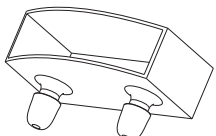
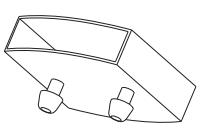
A		X1	F	 M8x30mm	X12	L		X1
B	 M8x10mm	X6	G	 M8x40mm	X24	M		X10
C	 M8x16mm	X50	H	 M8x50mm	X2	N		X2
D	 M8x18mm	X4	J		X24	P		X2
E	 M8x25mm	X4	K	 M8	X2	Q		X24
						S		X12

1

A x 1



B x 6



M8 x 10mm

M x 6

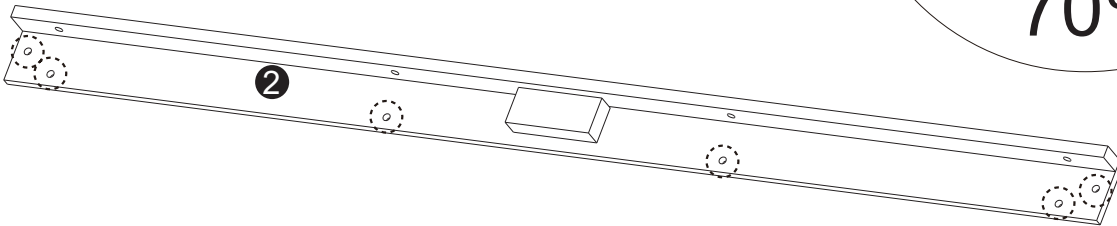
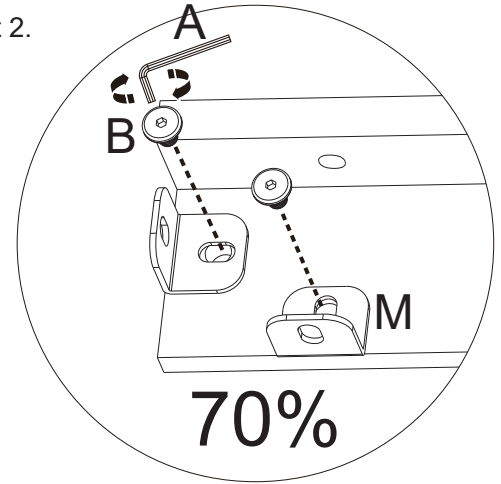

The bottom of the iron sheet needs to be flush with the edge of the part 2.
 Le fond de la tôle doit être affleuré avec le bord de la partie 2.
 Das blech muß mit der kante Von teil 2 ebenert werden.

**2**

A x 1



C x 4



M8 x 16mm

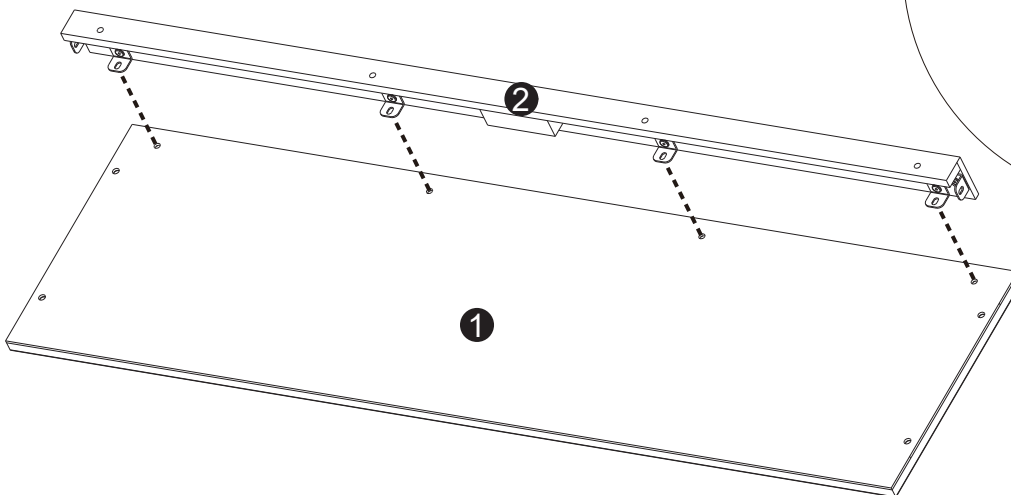
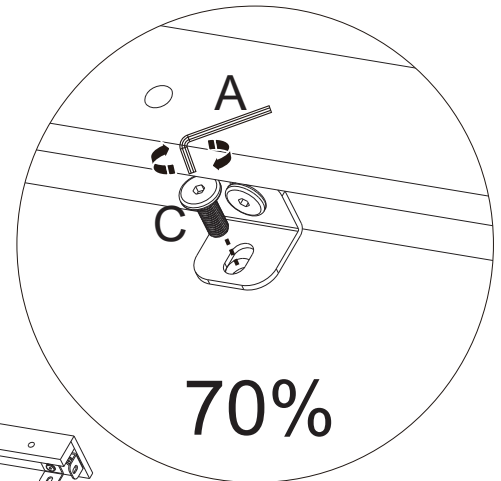

3

A x 1

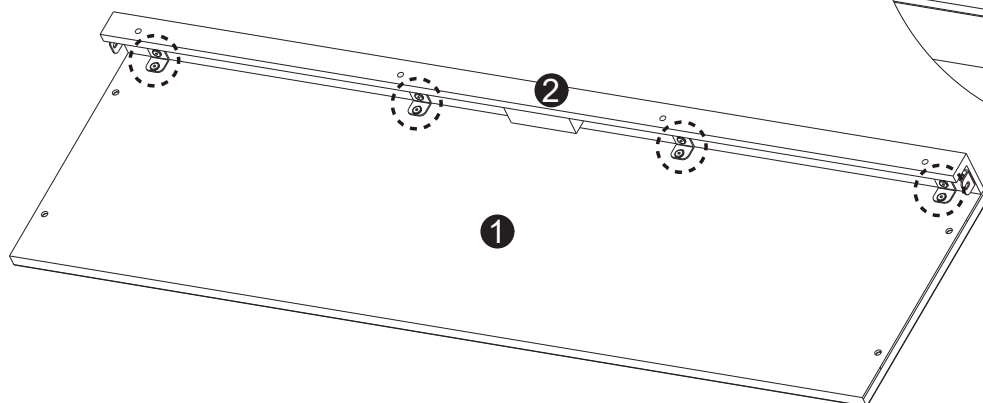
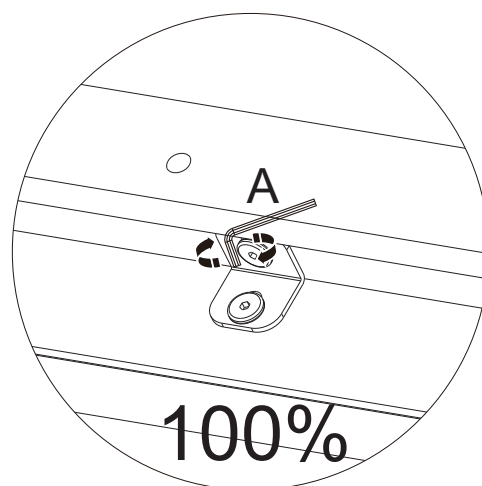

4

A x 1



F x 4



M8 x 30mm

J x 4

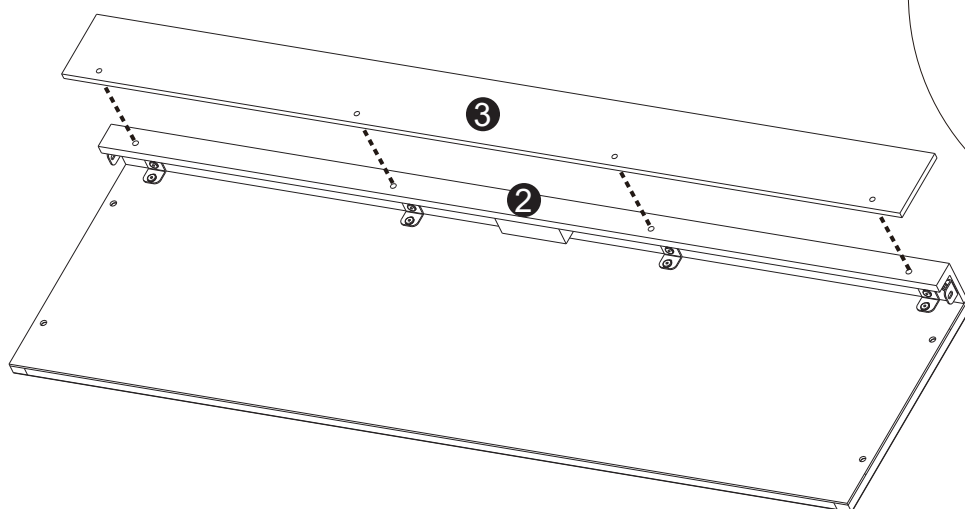
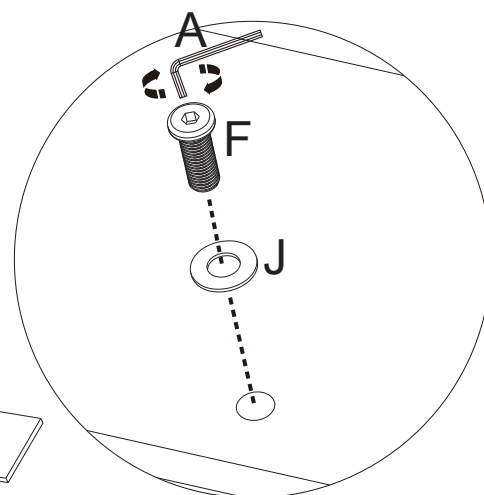

5

A x 1



C x 18



M x 4



N x 2

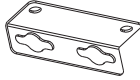

5R

1

5L

4

A

100%

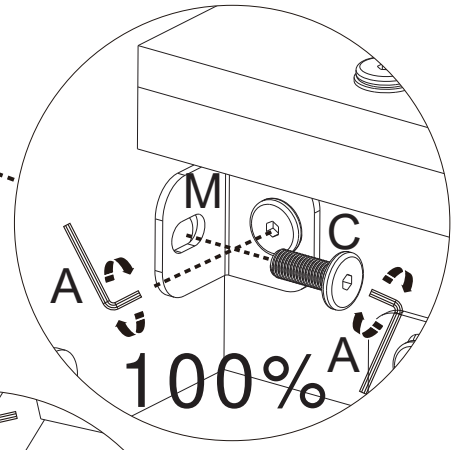
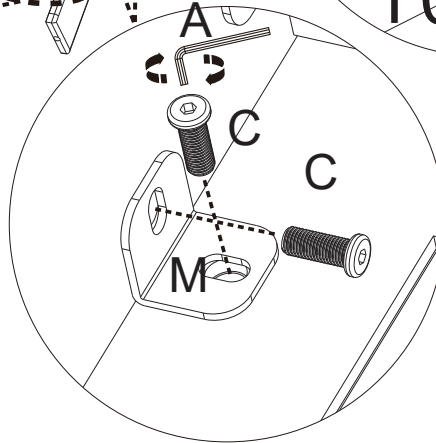
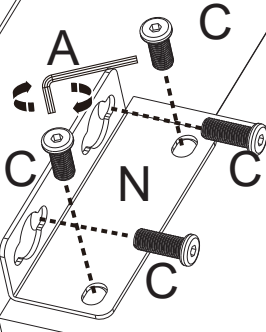
**6**

A x 1



C x 4



P x 2

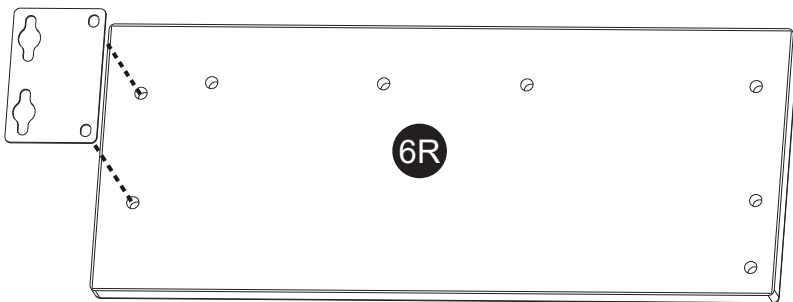
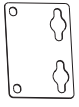

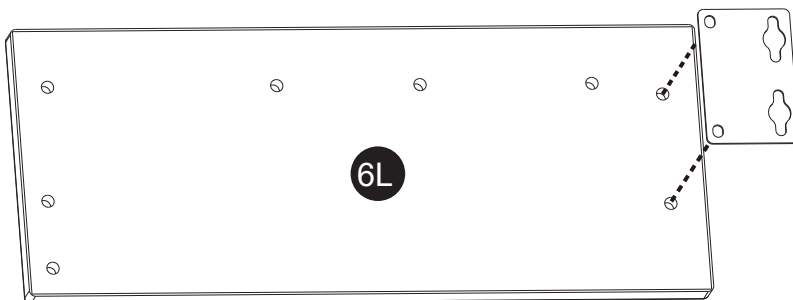

6R



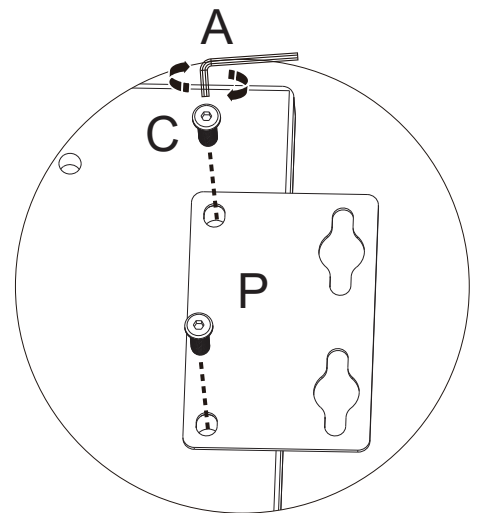

6L



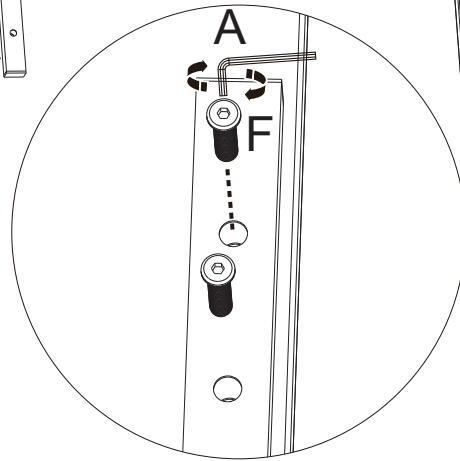
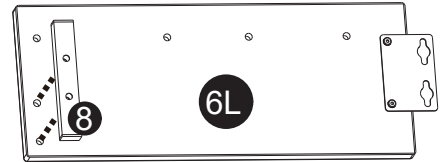
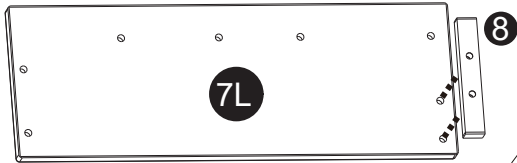
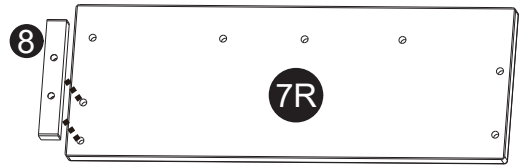
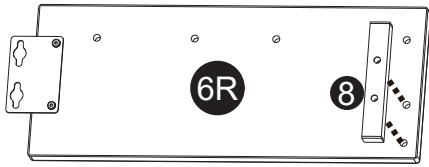

7	A x 1	F x 8
		 M8 x 30mm

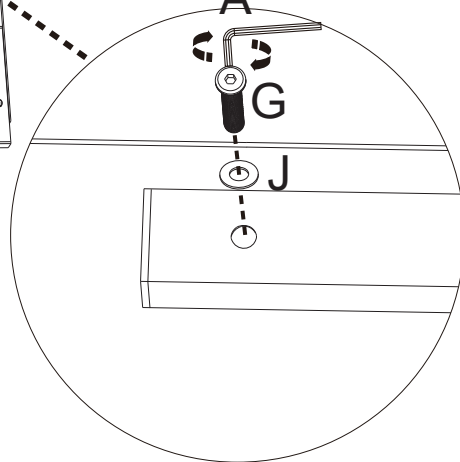
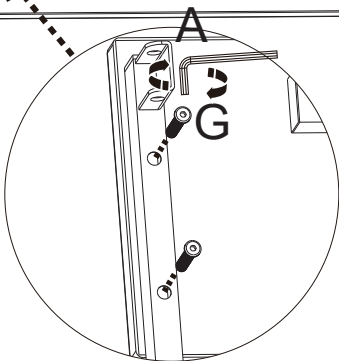
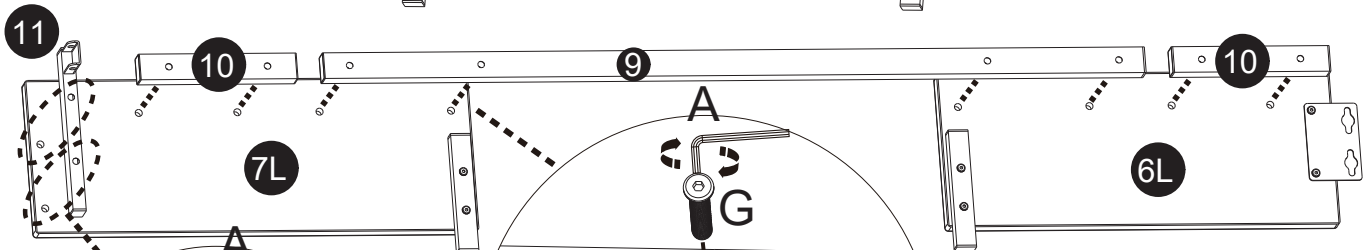
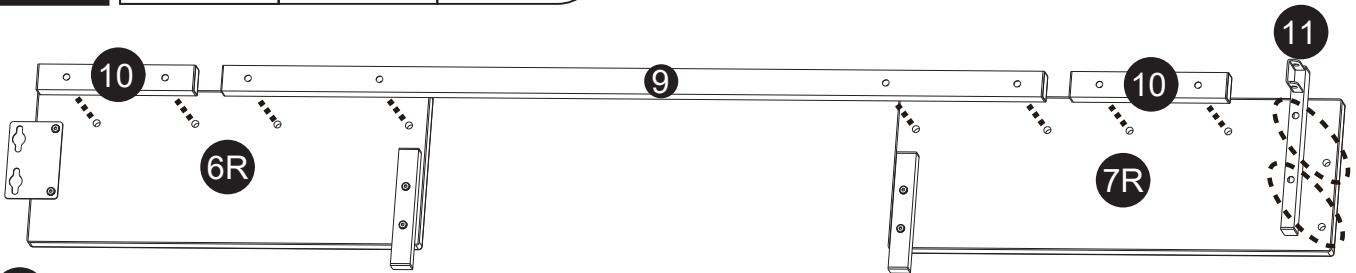

8	A x 1	G x 20	J x 16
		 M8 x 40mm	





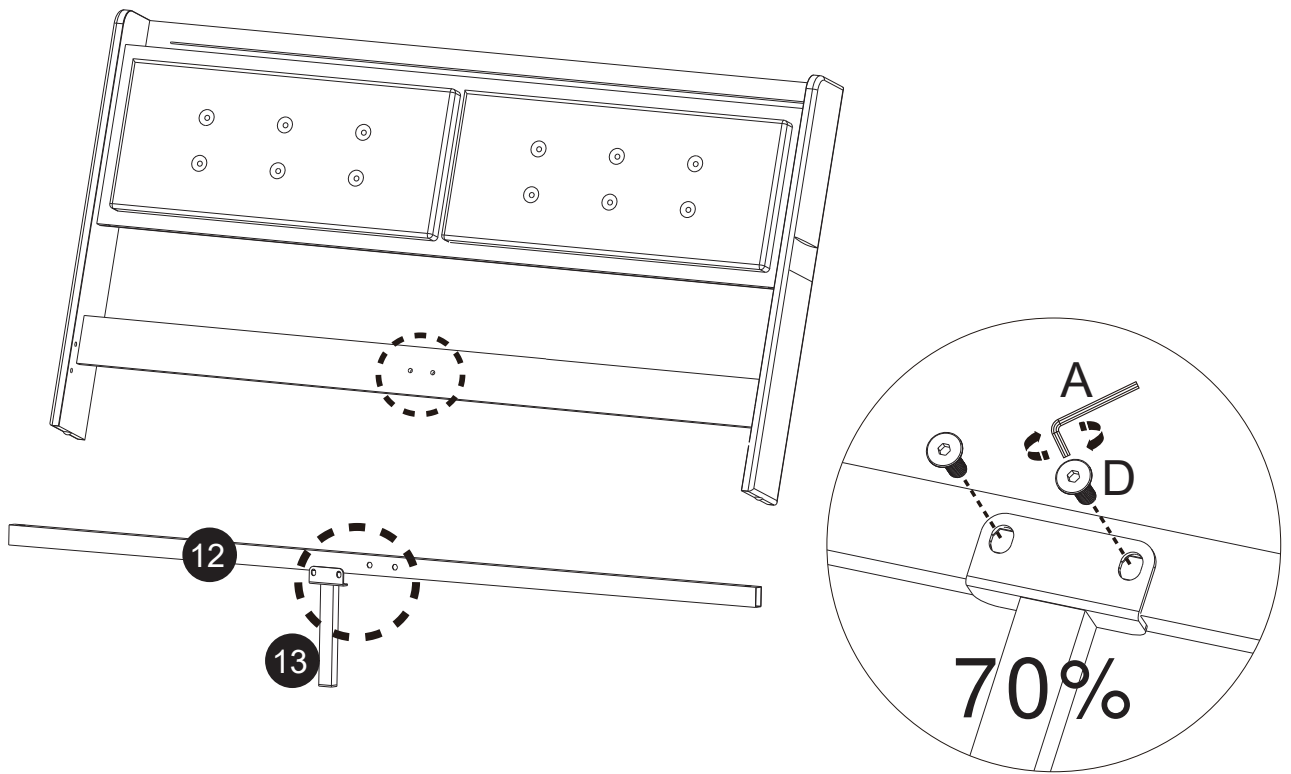

9

A x 1	D x 4
	
	M8 x 18mm



10

A x 1	H x 2	K x 2	L x 1
			
	M8 x 50mm		

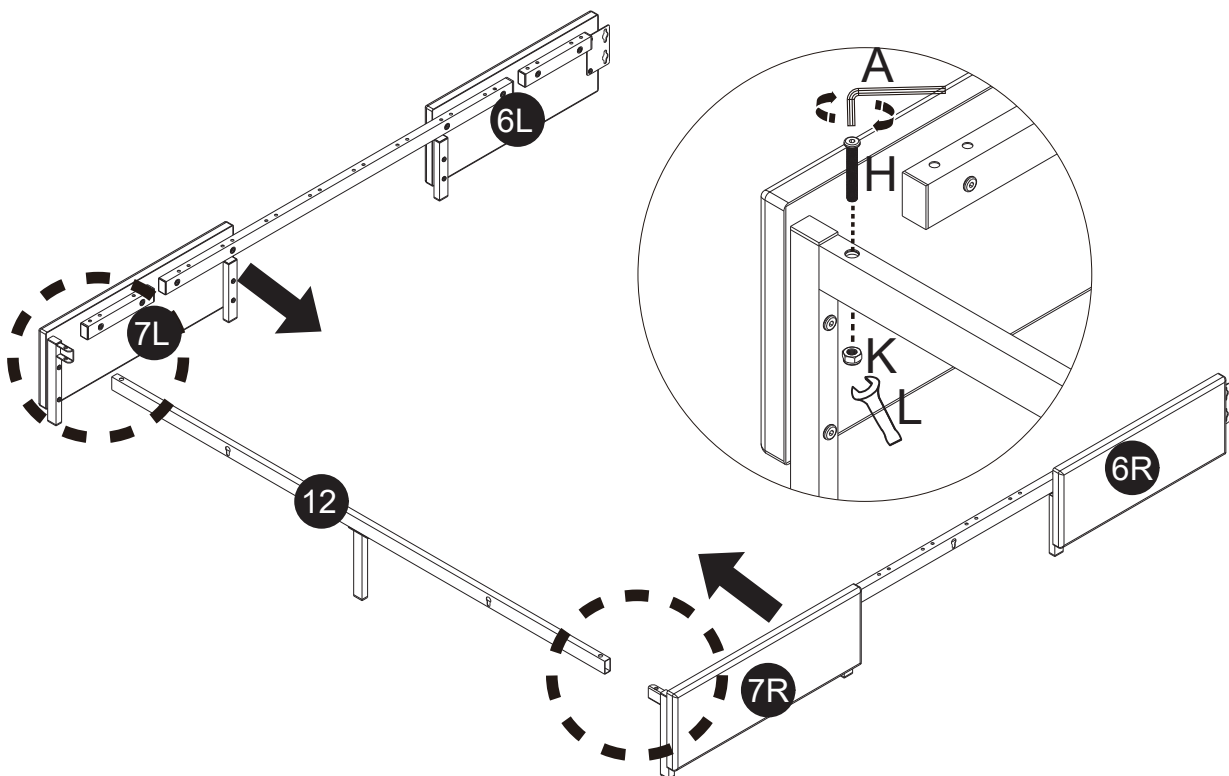

11

A x 1



C x 4



M8 x 16mm

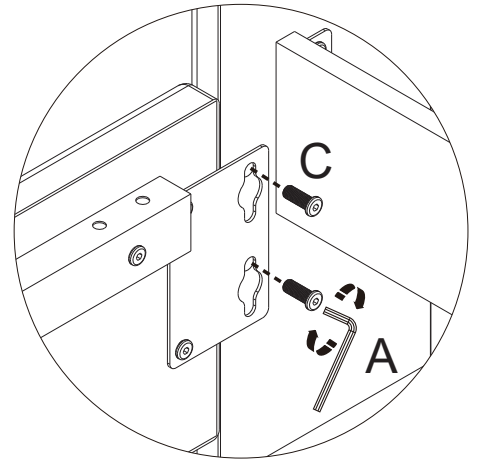
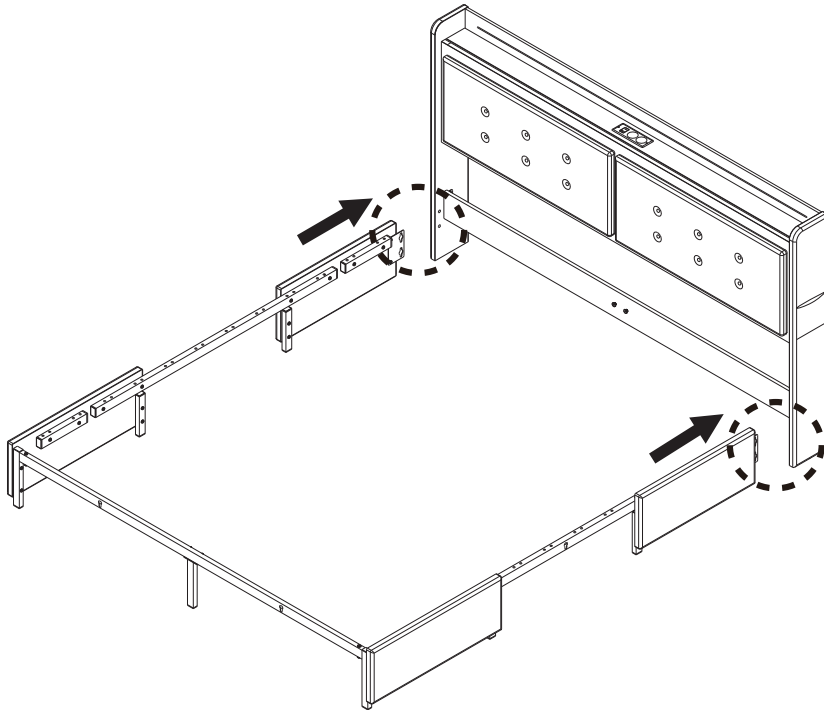

12

A x 1



G x 4



M8 x 40mm

J x 4

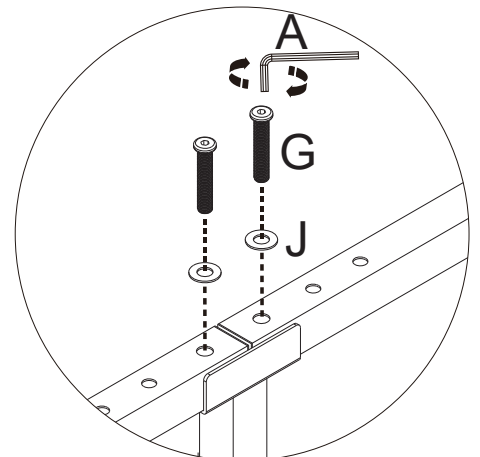
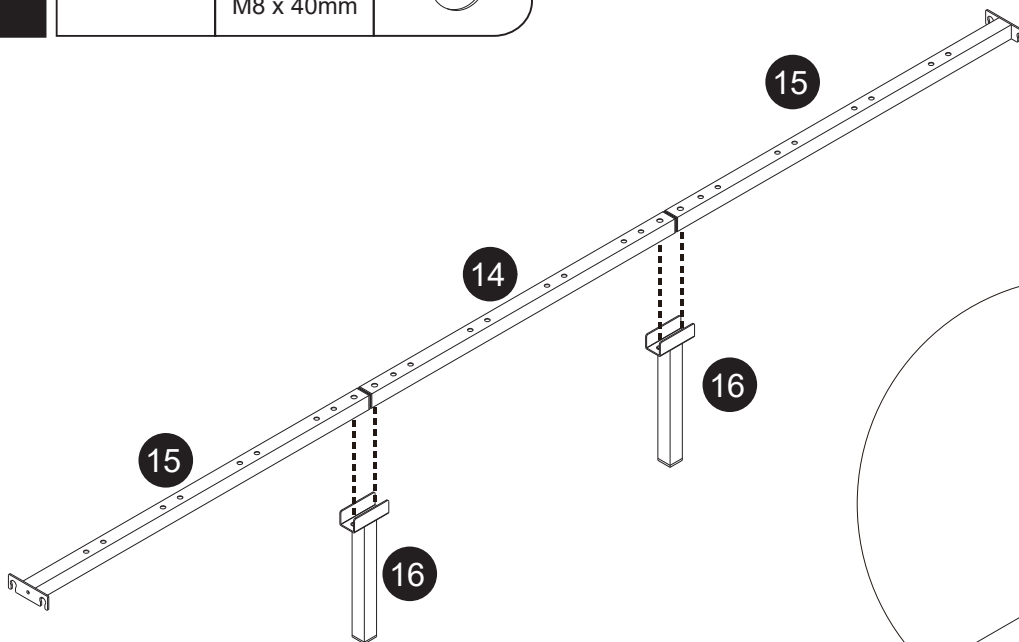

13

A x 1

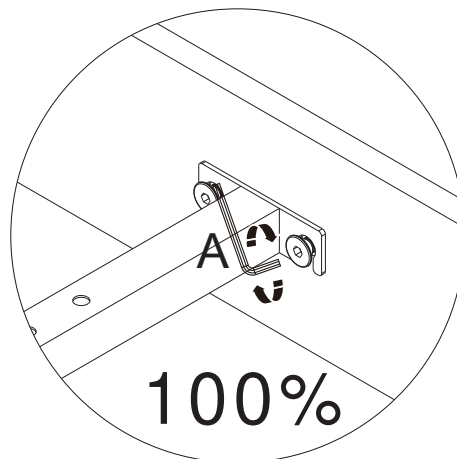
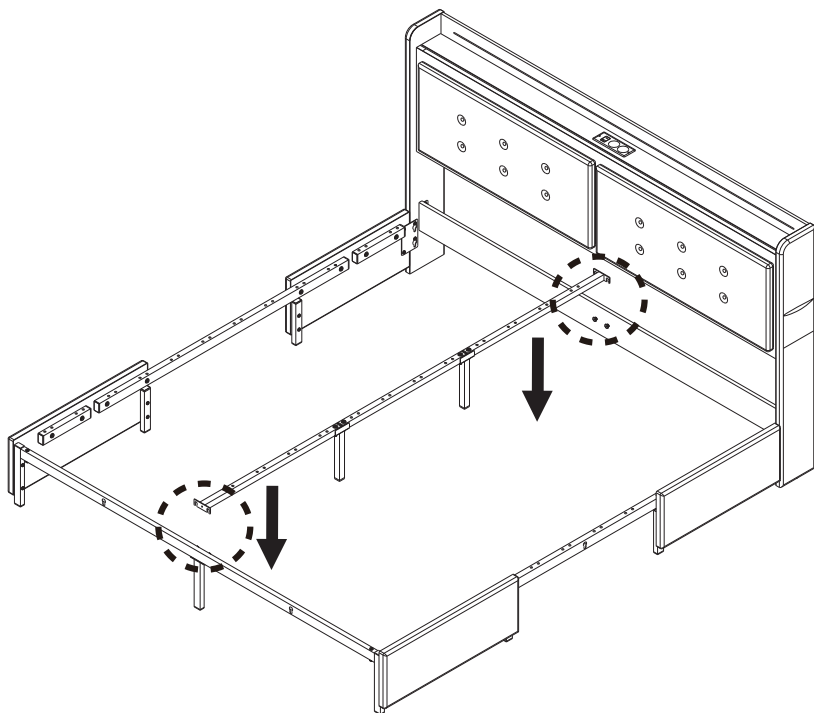

14

Q x 24

S x 12

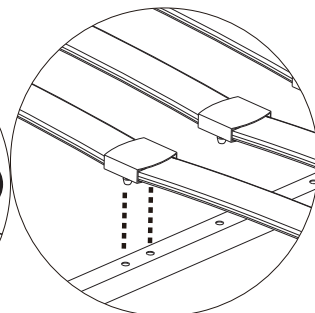
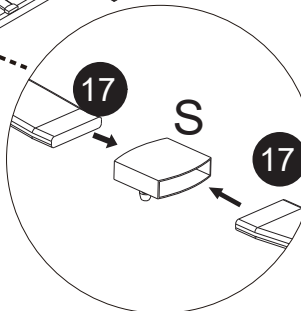
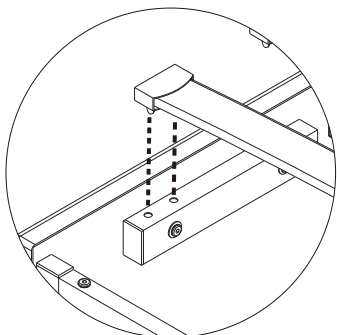
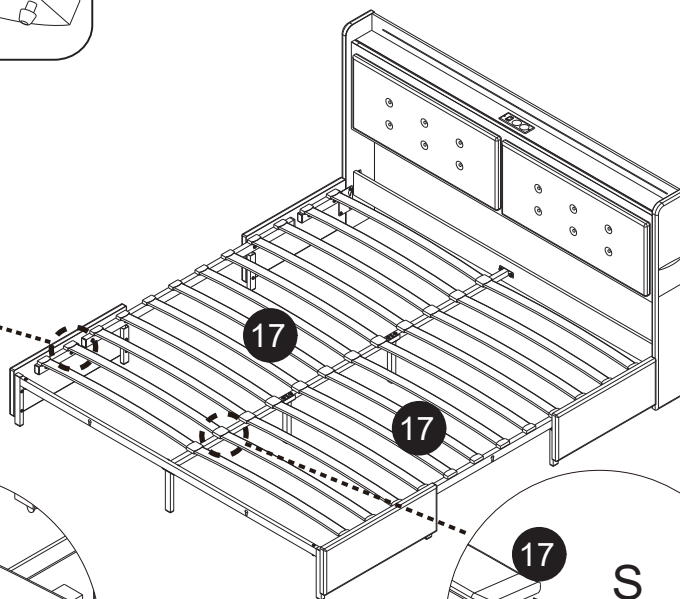
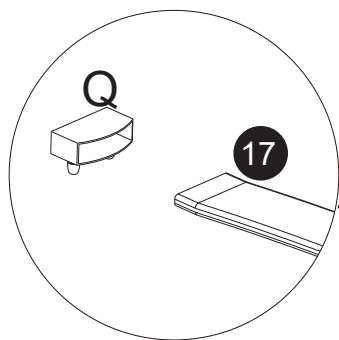
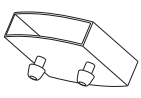
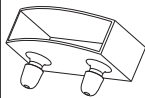

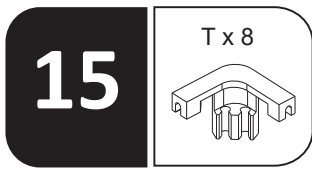

X 4

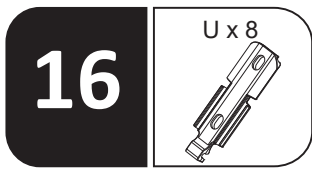
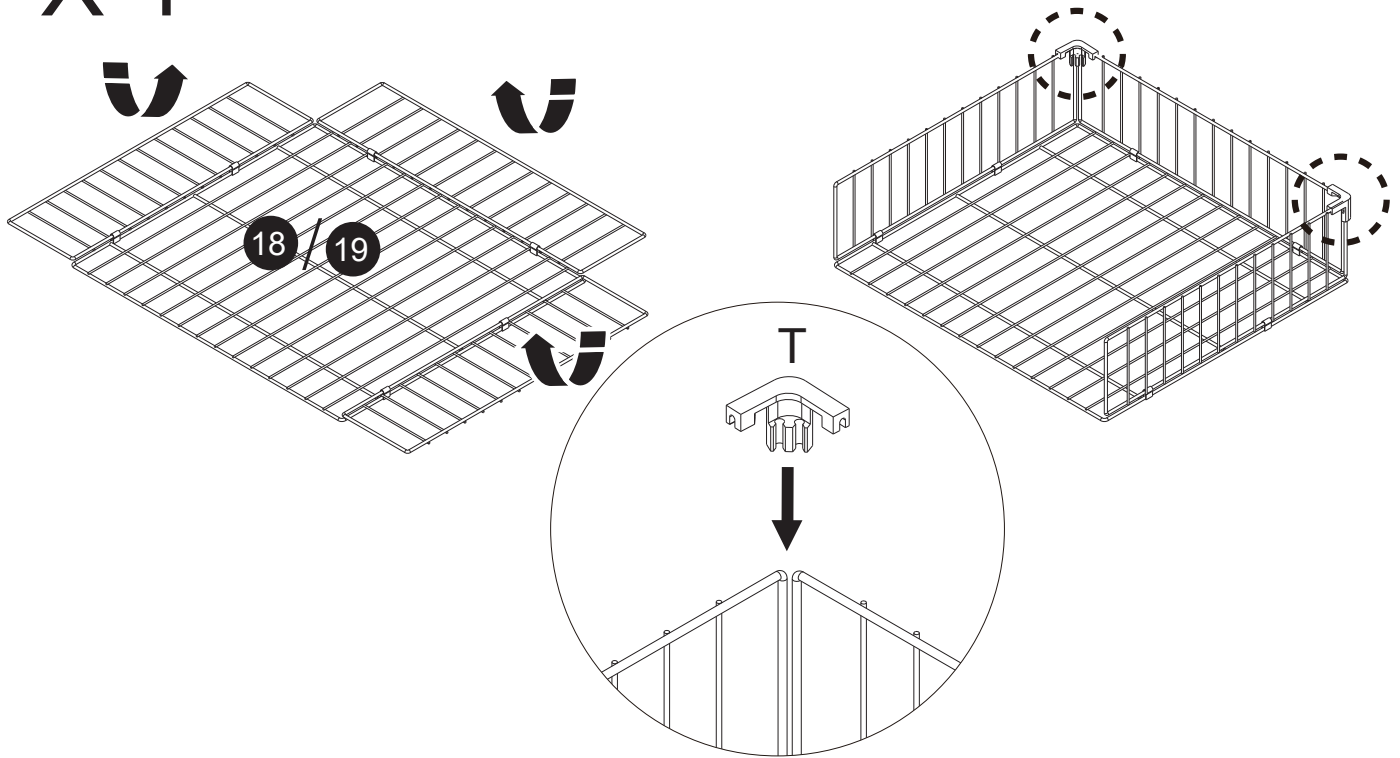

X 4

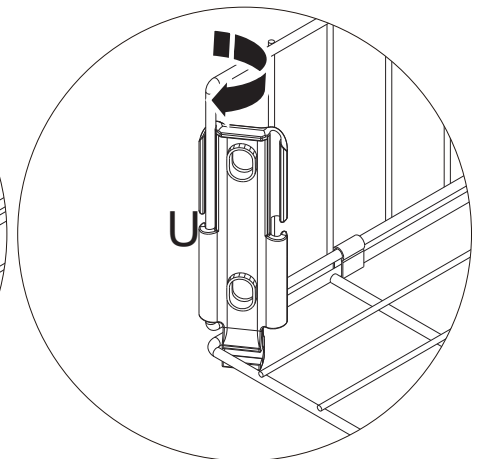
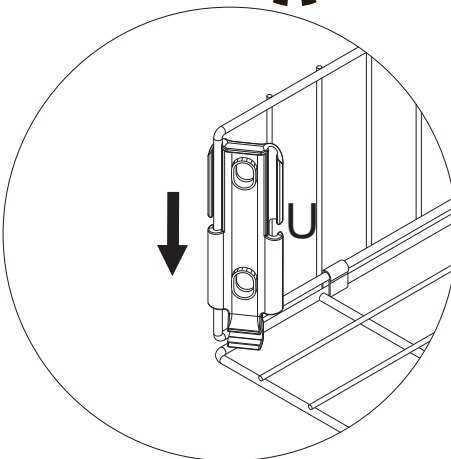
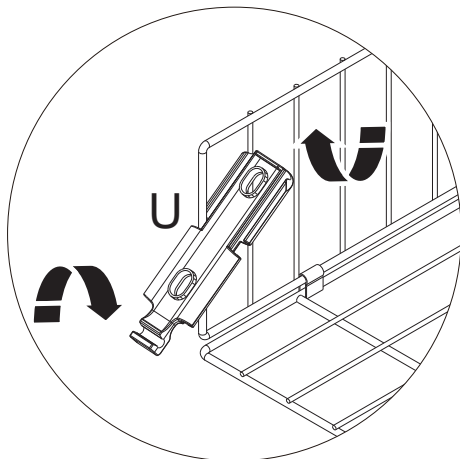
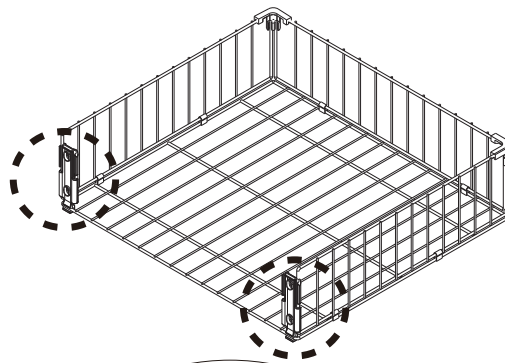

17

V x 16



X 4

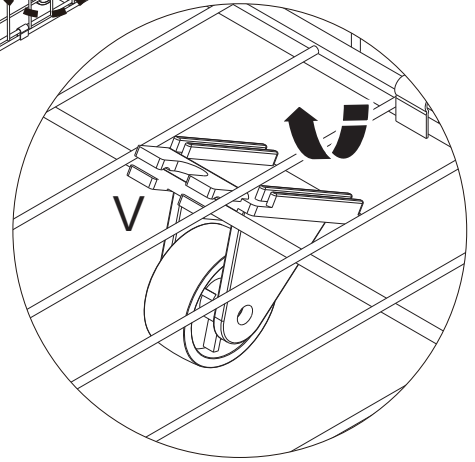
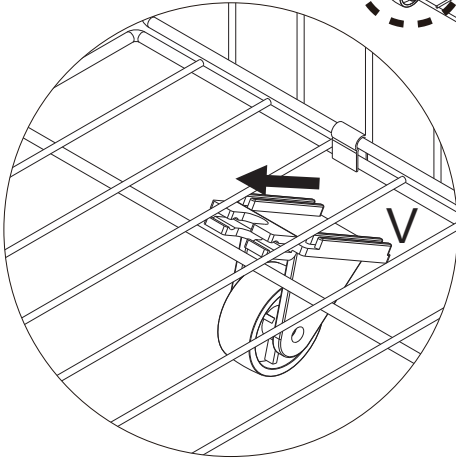
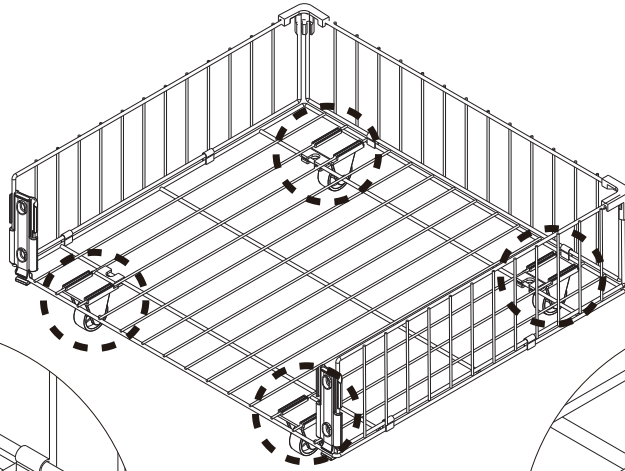

18

A x 1



C x 20



M8 x 16mm

E x 4



M8 x 25mm

W x 4



X 2

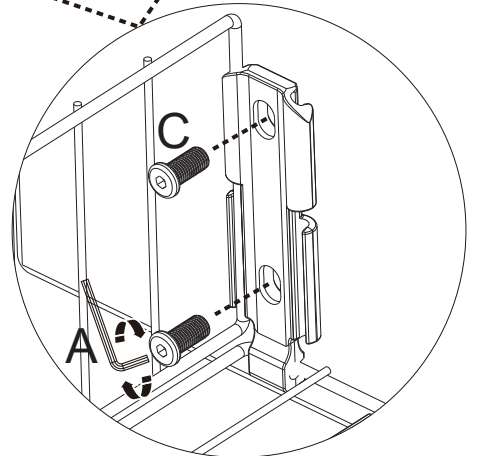
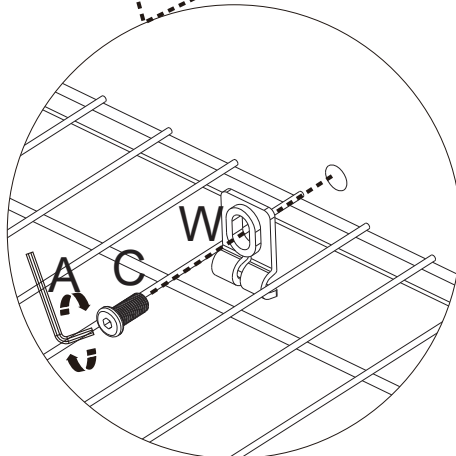
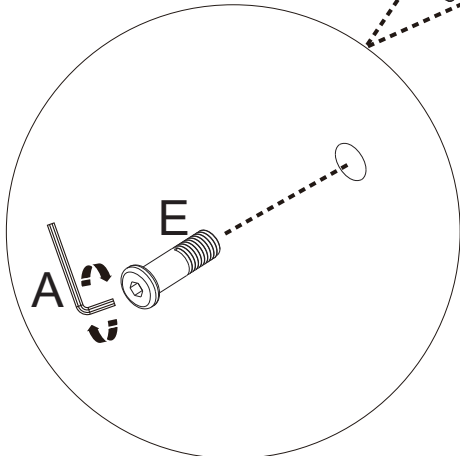
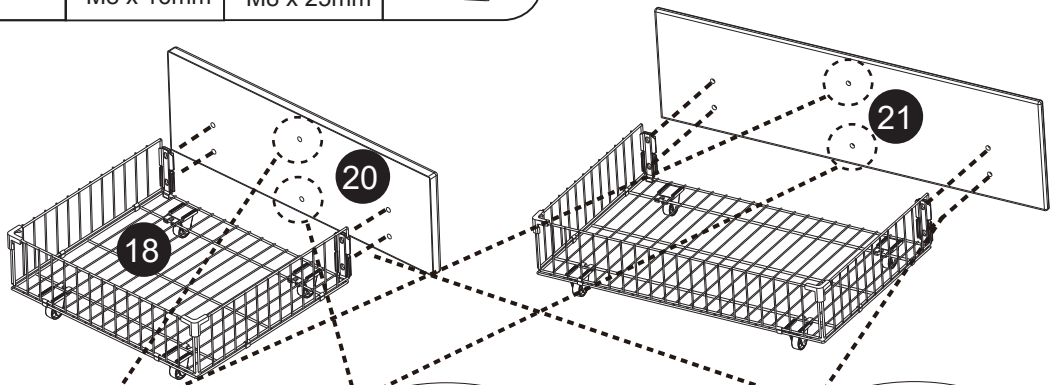

19

X x 1



Y x 1

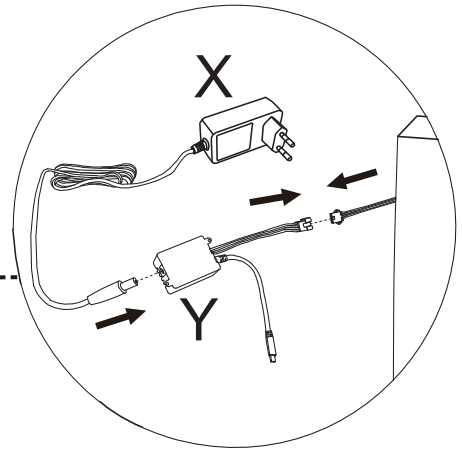
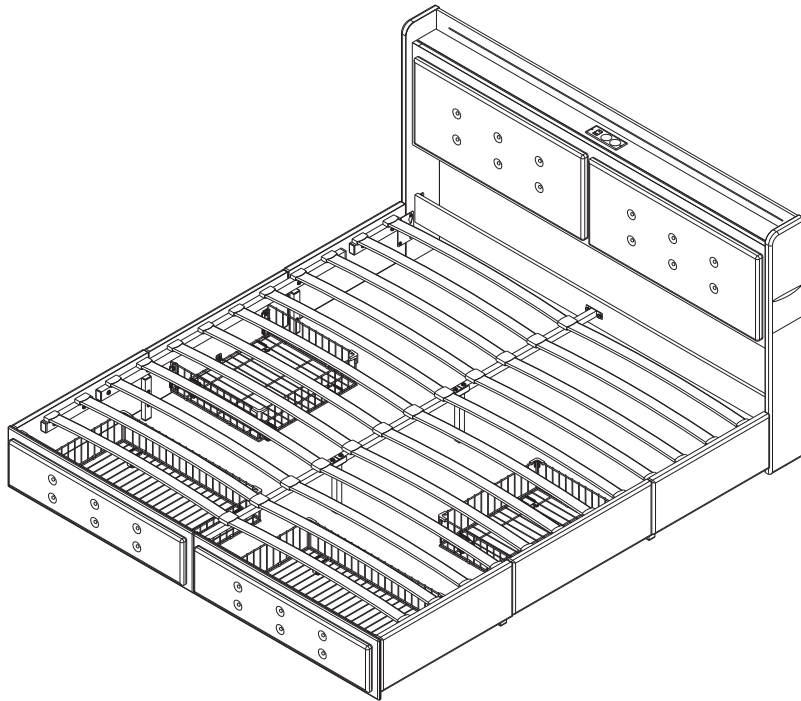

20

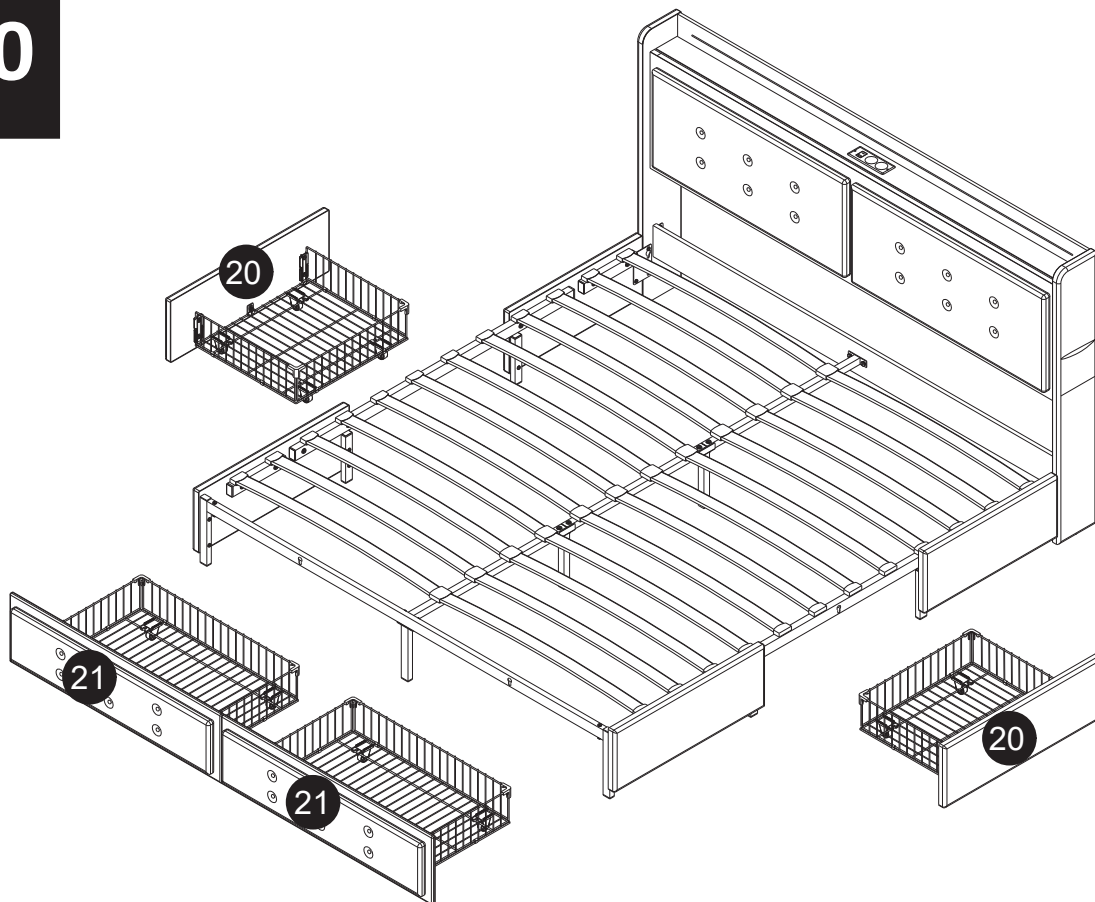

LED light

If you can't let the lights work successfully, please check the following:

1. Please check the direction of the connect, try it in the opposite direction, according to the following picture.
2. Please check the remote control, it need you to tear down the plastic septum before use it.
3. Don't let the remote control too far from the receiver, make sure there is no obstruction between them.
4. If one of the colors is not bright, please check whether the four wires in the plug are skewed, and move the main line to make the four wires flush.

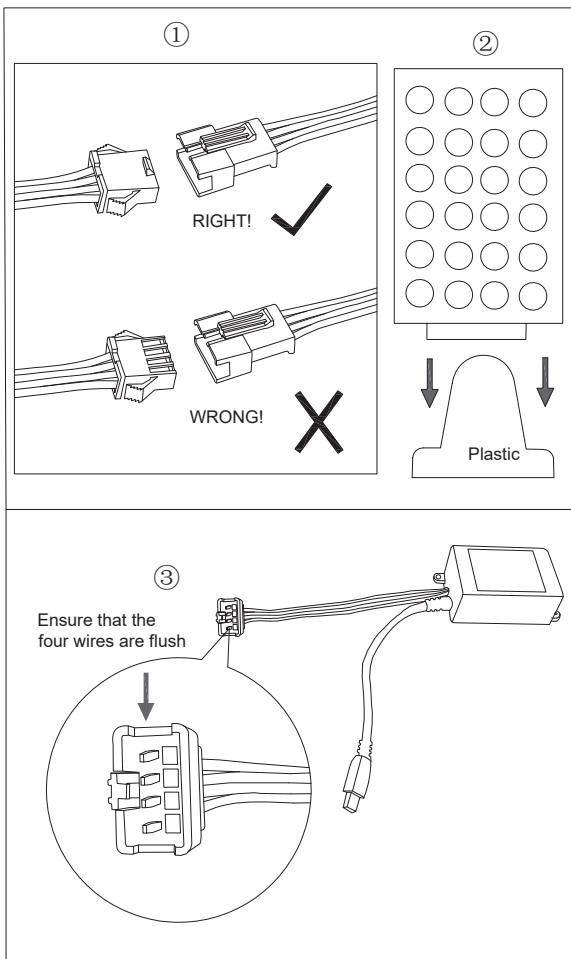

- 1 Please check the direction of the arrow
- 2 Please pull the plastic block out of the remote control
- 3 Please check whether the four wires of the plug are neat

Operation Instructions of Controller

I .Specifications:

Working temperature: -20-60 ℃ Supply voltage: DC12V
 Output: Three CMOS drain- open output Connecting Mode: Common anode
 Max load current: 2 A each color

II .Control Method:

Adopt IR remoter to control the led controller, which has 24 buttons, the function of each button as the table below:

Brightness +(Speed up)	Brightness -(Speed down)	Off	On
Static red	Static green	Static blue	Static white
Static orange	Static pea green	Static dark blue	7 color jumpy change
Static dark yellow	Static cyan	Static brown	All fade out&fade in
Static yellow	Static light blue	Static pink	7 color fade change
Static straw yellow	Static sky blue	Static purple	3 base color jumpy

III. Panel specification and connecting drawing as follows:

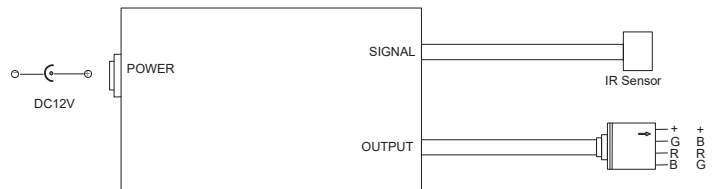

IV. Warning:

1. Supply voltage of this product is DC12V never connect to DC24V or AC220V.
2. Never connect two wires directly in case of short circuit.
3. Lead wire should be connected correctly according to colors that connecting diagram offers.
4. Warranty of this product is one year, in this period we guarantee replacement or repairing with no charge, but exclude the artificial situation of damaged or overload working.

! WARNING

THIS PRODUCT CONTAINS A BUTTON BATTERY
 If swallowed, a lithium button battery can cause severe or fatal injuries within 2 hours.
 Keep batteries out of reach of children.
 If you think batteries may have been swallowed or placed inside any part of the body, seek immediate medical attention.

Certificate of Compliance

Certificate No.: PRMS2205006SC

Holder : Shenzhen Boyaxuan Technology Development Co., Ltd.
3 / F, building 1, No.8, Xingye 1st Road, Fenghuang
community, Fuyong Street, 518103 Shenzhen, PEOPLE'S
REPUBLIC OF CHINA

Manufacturer : Shenzhen Boyaxuan Technology Development Co., Ltd.
3 / F, building 1, No.8, Xingye 1st Road, Fenghuang
community, Fuyong Street, 518103 Shenzhen, PEOPLE'S
REPUBLIC OF CHINA

Trade Mark : N/A

Product : AC/DC Adapter

Model(s) : BYX2-XXXYYYYZ
(‘XXX’=050 to 252, indicates 3 digit numbers which represents output
voltage in V after diving by 10; ‘YYYY’=0010 to 4000, indicates 4 digit
numbers which represents output current in A after diving by 1000;
Z= E, C or blank)

Rating : Input: 100-240Vac, 50/60Hz, 0.5A Max.
Output: See report

Test Standard : EN 62368-1:2014+A11:2017

The EUT described above has been tested by us with the listed standards and found in compliance with the council LVD directive 2014/53/EU. It is possible to use CE marking to demonstrate the compliance with this LVD Directive. It is only valid in connection with the test report number, PRMS2205006SR.



This Certificate of Conformity is based on single evaluation of the submitted sample(s) of the above mentioned product. It does not imply an assessment of the whole product and relevant . Directives have to be observed.



Shenzhen Promise Testing Technology Co., Ltd.
103, Building 1, Yibaolai Industrial City, Qiaotou Community,
Fuhai Street, Bao'an District, Shenzhen, Guangdong, China



Certificate of Compliance

Certificate NO.: PRMS2205006EC01

Holder : Shenzhen Boyaxuan Technology Development Co., Ltd.
3 / F, building 1, No.8, Xingye 1st Road, Fenghuang community,
Fuyong Street, 518103 Shenzhen, PEOPLE'S REPUBLIC OF CHINA

Manufacturer : Same as Hodler

Product : AC/DC Adapter

Model(s) : BYX2-0504000, BYX2-2521100 (See section 2.2 of the report)

Trade Mark : 

Test Standard : EN 55032:2015/A11:2020
EN 55035:2017/A11:2020
EN IEC 61000-3-2:2019/A1:2021
EN 61000-3-3:2013/A2:2021

The EUT described above has been tested by us with the listed standards and found in compliance with the council EMC Directive 2014/30/EU. It is possible to use CE marking to demonstrate the compliance with this EMC Directive. It is only valid in connection with the test report number: PRMS2205006ER-01.



Approved by

Authorized signatory May. 25, 2022



This Certificate of Conformity is based on single evaluation of the submitted sample(s) of the above mentioned product. It does not imply an assessment of the whole product and relevant Directives have to be observed.



+86-0755-23319501

info@pnms-test.com

www.pnms-test.com



CERTIFICATE OF CONFORMITY

Electromagnetic Compatibility (EMC) Directive 2014/30/EU

This Certificate of Conformity is hereby issued to the product designated below:

Certificate No. : 23EP08001E01
Report No. : EP2308001E01
Date Issue. : 2023-08-23
Applicant's name : Shenzhen MingFuXin Furniture Electrical Appliances Co., Ltd.
Address : 4 F, building a, No. 8, Chenwu Road, Dakang community, Yuanshan street, Longgang District, Shenzhen
Manufacturer's name : Shenzhen MingFuXin Furniture Electrical Appliances Co., Ltd.
Address : 4 F, building a, No. 8, Chenwu Road, Dakang community, Yuanshan street, Longgang District, Shenzhen
Product Description : Socket
Model(s)/Type References : OAZ-XXXX(The 1st "X" represents the switch, 0-1, the 2nd "X" represents the number of sockets 1-4, the 3th "X" represents the number of USB 1-3 (1 is double A, 2 is A+C,3 is double C), and the 4th "X" represents the wireless charge 0-1)
Parameters : See attachment for details
Standard(s) : EN 55032:2015+A11:2020+A1:2020
EN 55035:2017+A11:2020
EN IEC 61000-3-2:2019+A1:2021
EN 61000-3-3:2013+A1:2019+A2:2021

On the basis of the referenced test report(s), sample(s) tested of the above product have been found to comply with the standards harmonized with the directives listed on this verification at the time the tests were carried out. Other standards and Directives may be relevant to the product. This verification is part of the full test report(s) and should be read in conjunction with it(them).

Once compliance with all product relevant CE mark directives are verified, including any relevant e.g. risk assessment and production control, the manufacturer may indicate compliance by signing a Declaration of Conformity themselves and applying the mark to products identical to the tested sample(s).

Approved By

Eric Liu
Director of engineering department

Dongguan Pubiao Testing Technology Co., Ltd

No. 3, 1/F., Building A, No.30, Minghua Road, Juzhou, Shijie, Dongguan, Guangdong, China

Tel: +86 769 81813516 E-mail: service@pubiaotest.com Web: www.pubiaotest.com



CERTIFICATE OF CONFORMITY

Electromagnetic Compatibility (EMC) Directive 2014/30/EU

Appendix of Certificate No.: 23EP08001E01

Parameters:

Input: 220-250Vac, 50Hz, 10A

Output: AC socket: 2500W max

1)For USBA+Type-C output:

Type-C: 5VDC3A/9VDC2.22A/12VDC1.67A

USBA:5VDC3A/9VDC2A/12VDC1.5A

Type-C&USB: 5VDC/3A

Wireless:15W max

2)For double C output:

Type-C1: 5VDC3A/9VDC2.22A/12VDC1.67A

Type-C2:5VDC3A/9VDC2A/12VDC1.5A

Type-C1&Type-C2: 5VDC/3A

Wireless:15W max

3)For double A output:

USBA1:5VDC 2.1A

USBA2:5VDC 2.1A

USBA1&USBA2:5VDC/2.1A

Wireless:15W max



Dongguan Pubiao Testing Technology Co., Ltd

No. 3, 1/F., Building A, No.30, Minghua Road, Juzhou, Shijie, Dongguan, Guangdong, China

Tel: +86 769 81813516 E-mail: service@pubiaotest.com Web: www.pubiaotest.com