

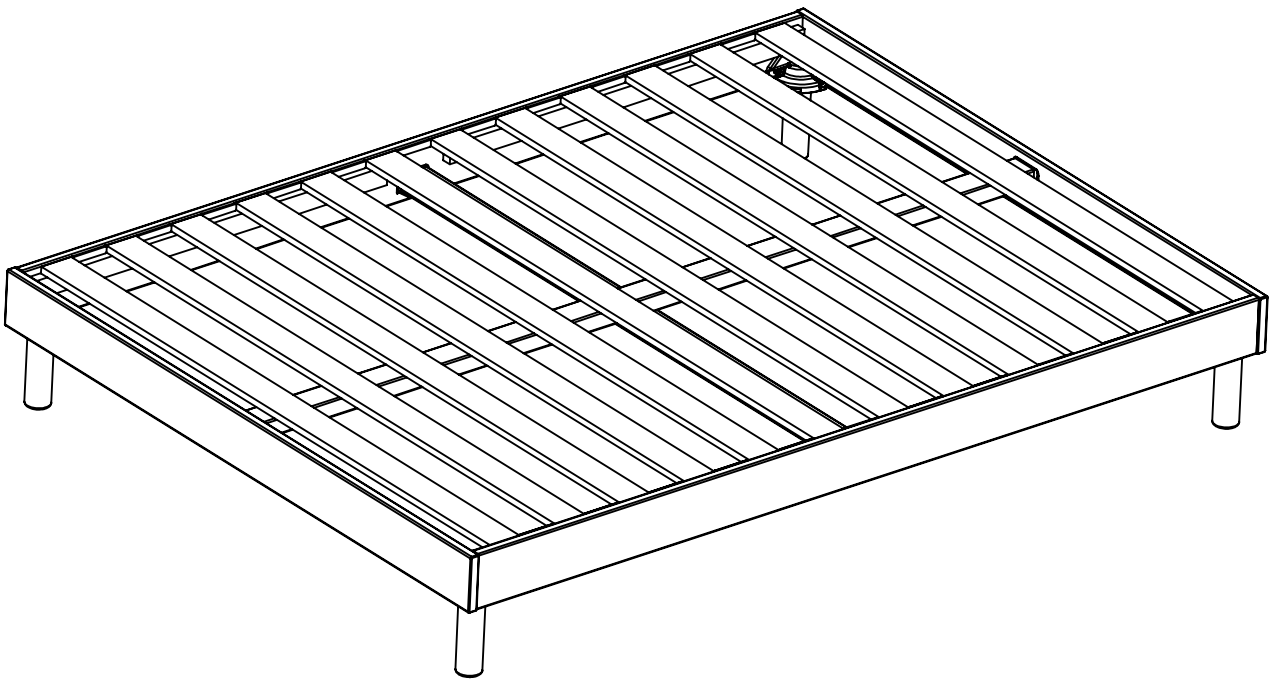







	<p>6@5B7</p>	<p>- \$L% \$'Wb  - \$L&amp;\$\$'Wb  %&amp;\$L% \$'Wb  %(\$L% \$'Wb  %(\$L&amp;\$\$'Wb  %*\$L&amp;\$\$'Wb</p>

V\ u@- ) - U\ Vu° 8-

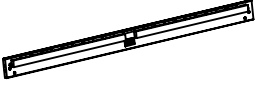

?' \$6

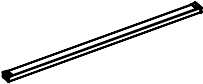

		- \$L% \$' # - \$L&\$\$	%&\$L% \$	%( \$L% \$' # %( \$L&\$\$	%* \$L&\$\$
8 9G7 "					
		6@B 7	6@B 7	6@B 7	6@B 7
	FYZ'	5	5	5	5
	5 ft'	&\$" "\$%"\$\$\$\$") * - '# &\$" "\$%"\$\$\$\$") +-	&\$" "\$%"\$\$\$\$") * -	&\$" "\$%"\$\$\$\$") * - '# &\$" "\$%"\$\$\$\$") +-	&\$" "\$%"\$\$\$\$") +-
	E hf"	&L	&L	&l	&l
	FYZ'	6	6	6	6
	5 ft'	&\$" "\$%"\$\$\$\$")(((	&\$" "\$%"\$\$\$\$")((	&\$" "\$%"\$\$\$\$")(( *	&\$" "\$%"\$\$\$\$")(( +
	E hf"	&L	&L	&l	&l
	FYZ'	7	7	7	7
	5 ft'	&\$" "%&"\$\$\$\$" * ,	&\$" "%&"\$\$\$\$" * ,	&\$" "%&"\$\$\$\$" * ,	&\$" "%&"\$\$\$\$" * ,
	E hf"	(L	(L	(l	(l
	FYZ'	b"U"	8	8	8
	5 ft'	b"U"	&\$" "\$%"\$\$\$\$") +%	&\$" "\$%"\$\$\$\$") +%	&\$" "\$%"\$\$\$\$") +%&
	E hf"	b"U"	%L	%L	%L
	FYZ'	b"U"	9	9	9
	5 ft'	b"U"	&\$" "\$%"\$\$\$\$") +'	&\$" "\$%"\$\$\$\$") +(	&\$" "\$%"\$\$\$\$") +)
	E hf"	b"U"	%L	%L	%L
	FYZ'	:	:	:	:
	5 ft'	%\$"\$\$\$\$"\$\$\$%& &	%\$"\$\$\$\$"\$\$\$%&( -	%\$"\$\$\$\$"\$\$\$%&) \$	%\$"\$\$\$\$"\$\$\$%&) %
	E hf"	%&L	%&L	%&L	%&L

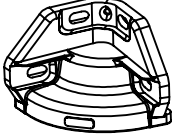
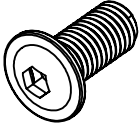
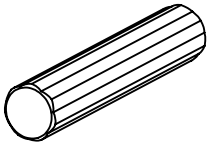
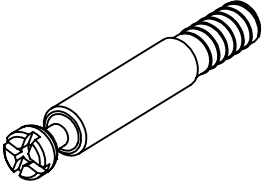
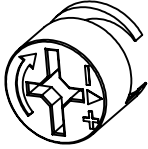
FYZ'	8YgW'	5 fh'	E hf''
<		%\$"\$%%"\$\$\$\$"&(&	(l
FYZ'	8YgW'	5 fh'	E hf''
%			%*l
&			(l
'			(l
(			(l

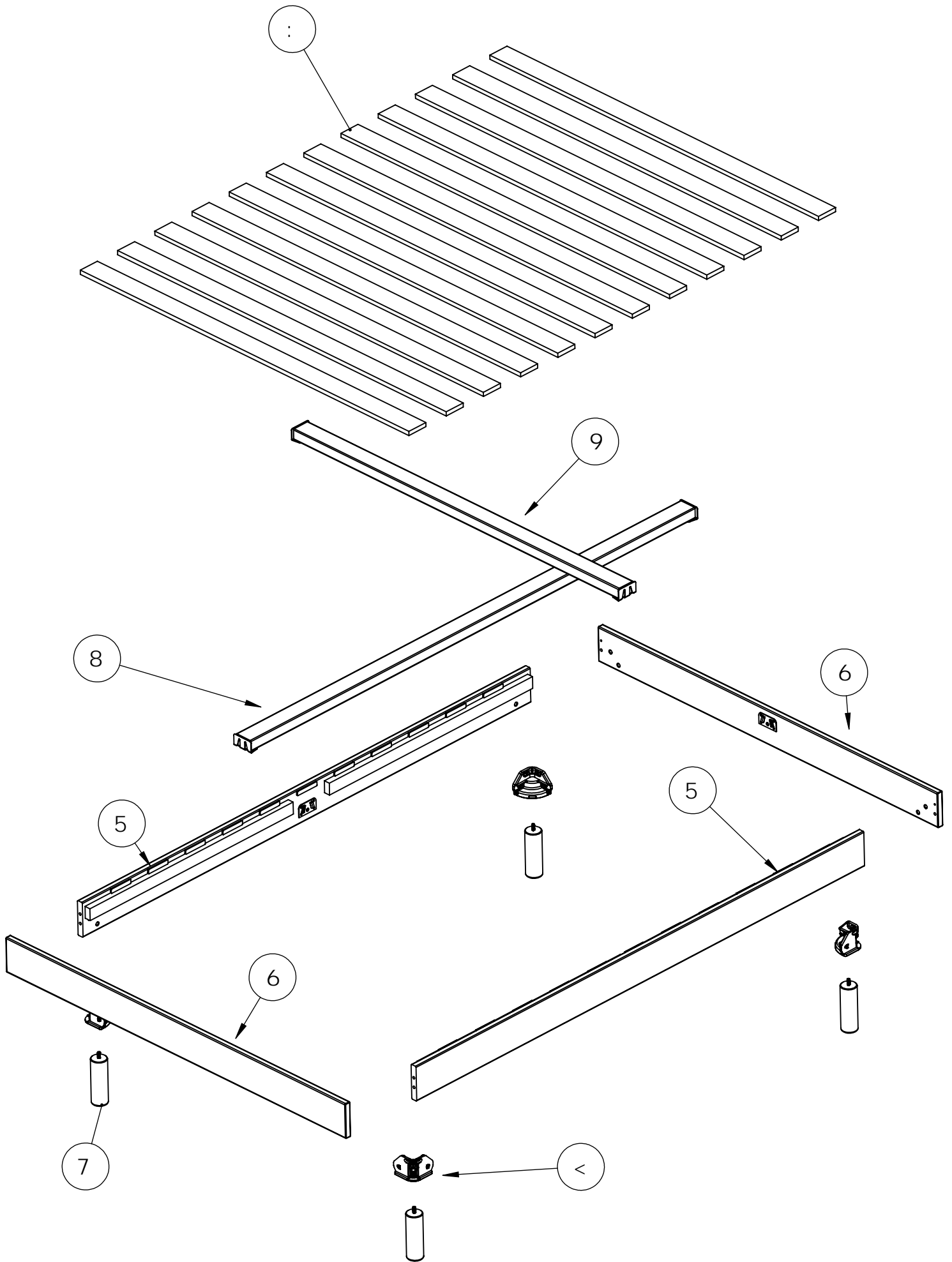

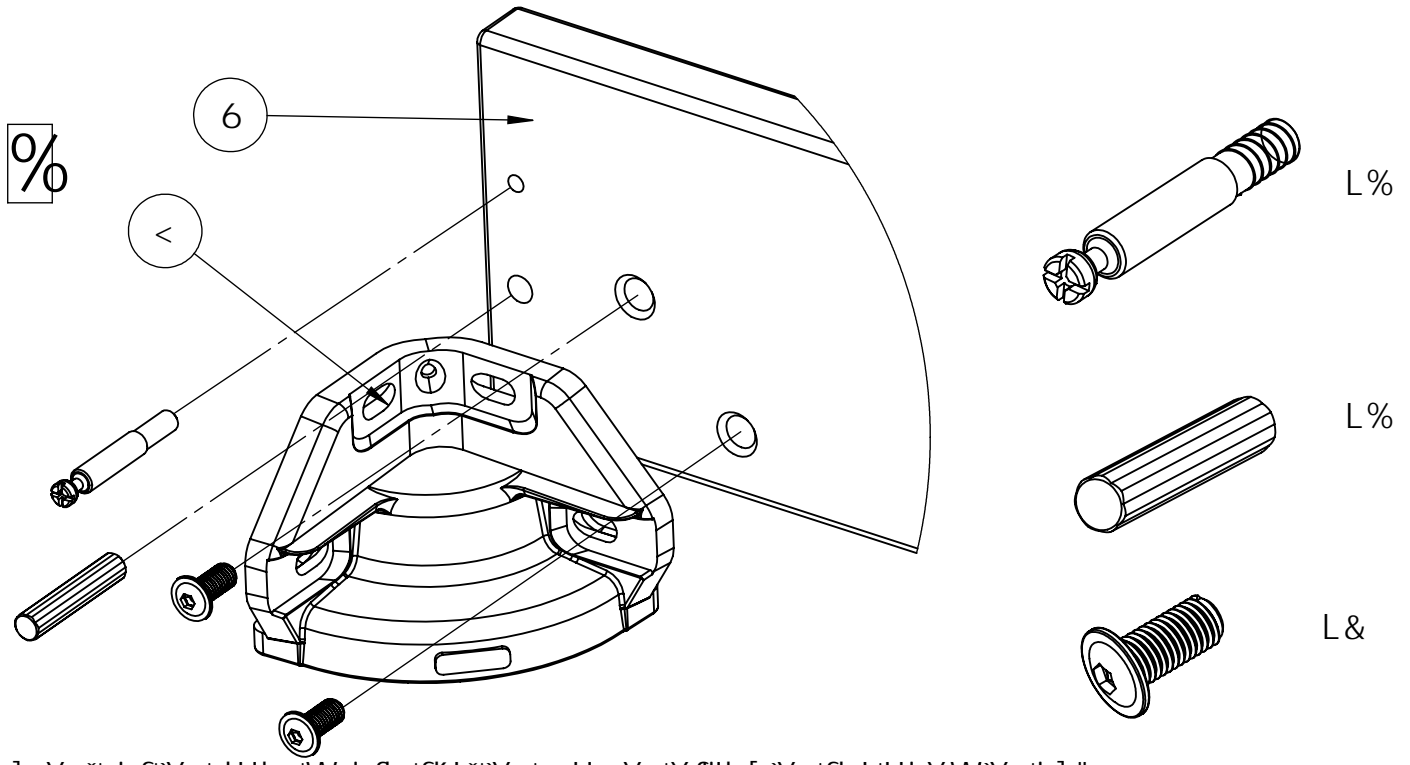

J ]ggYnžg f`YgdUbgWci fngf6Ł`Yga UggYgXfłb[ `YgfkŁUj YWYgj ]g'  
 G] "d" bY`dUggYffYf`Ygj ]ghcd `ZcfhYh`U]ggYnXi `Yi `↑gei fi `U Zp Xi `a cbhU[ Y"  
 ðgf fYn`Yghci f]`cbgYb`Vc ]gXUbgWUei Y`YI hf a ]f`XYgdUbgWci fng'

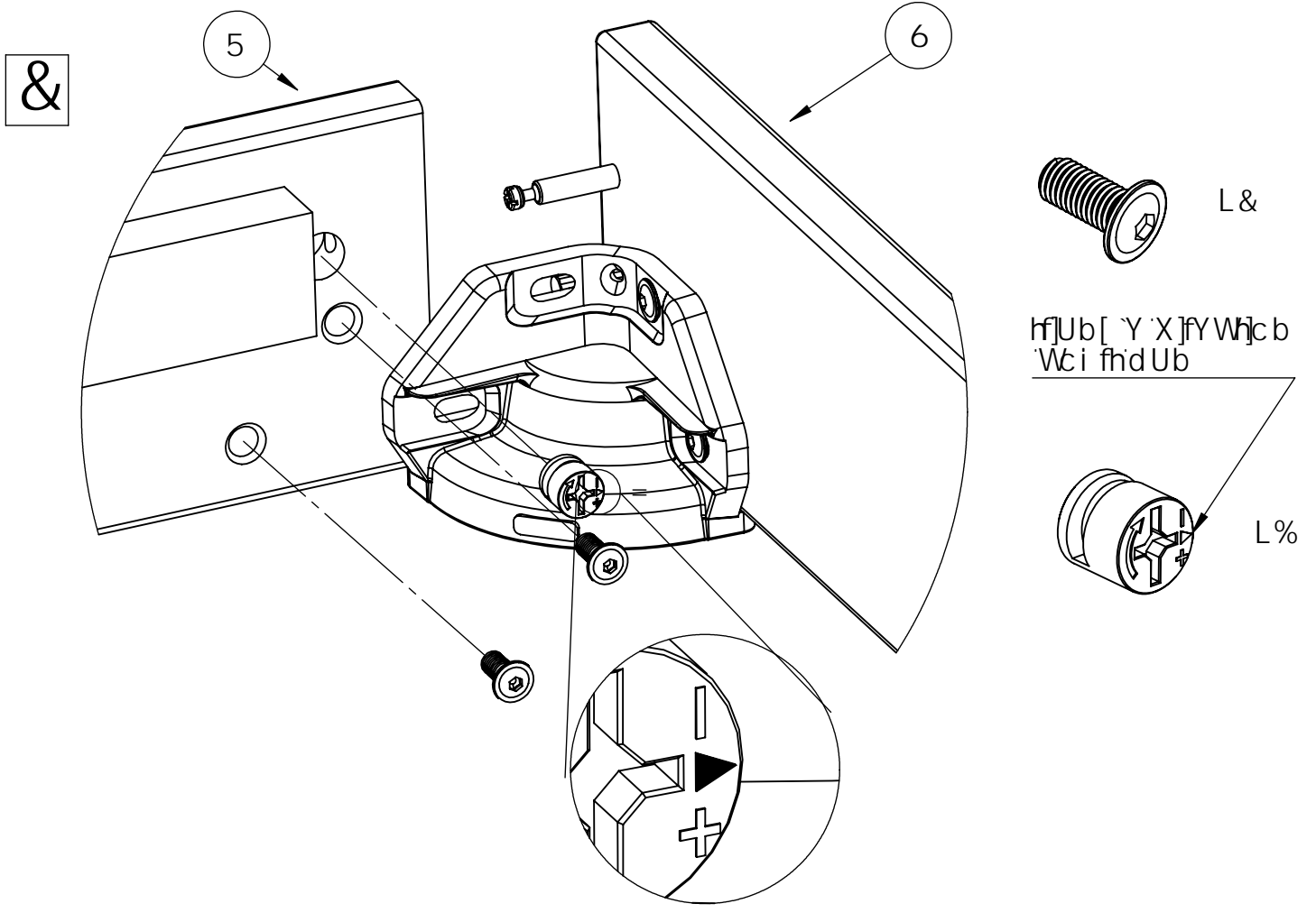

5 ][ bYn`Y`cb[ `dUb`Uj YWY`dUb`Wci fh'  
 ðgf fYn`U`ZYffi fY`YI W`bh]ei Y" G] "d" ZU]hYgUHybh]cb { `Ńcf]YbhU]cb XY`ŃW bY`Yb`hf]Ub[ Y`  
 [ fUj f`ei f]`gY`X]f[ Y`j Yfg`Y`dUb`Wci fh'  
 J ]ggYn`Yga UggYgXfłb[ `YgfkŁXUbg`Yg`cb[ g`dUbgYhgYffYn`U`ZYffi fY`YI W`bh]ei Y"



5

<

6

7

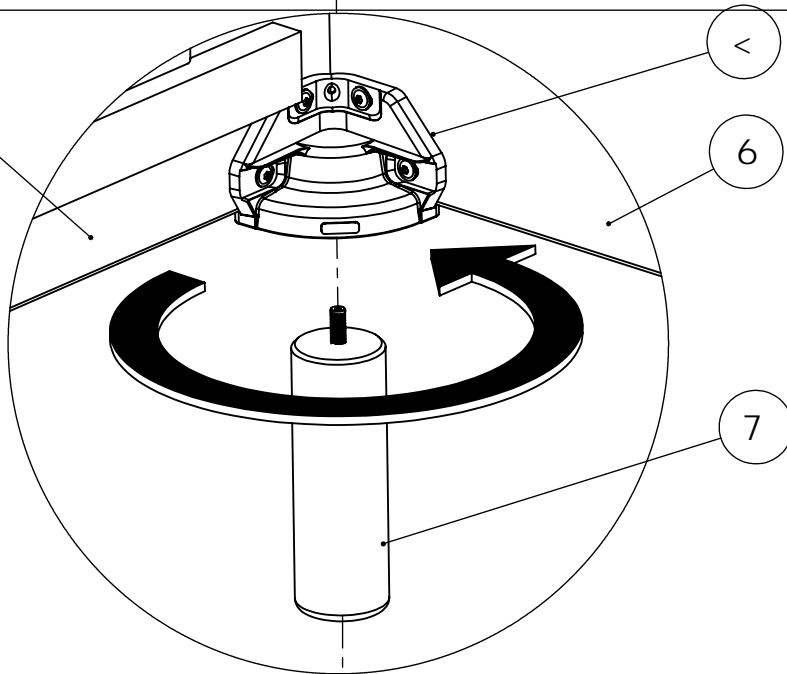

J lggYf`Yg( 'd]YXgf7 ŁXUbg`Y( 'a UggYgXfłb[ `YgfkŁ

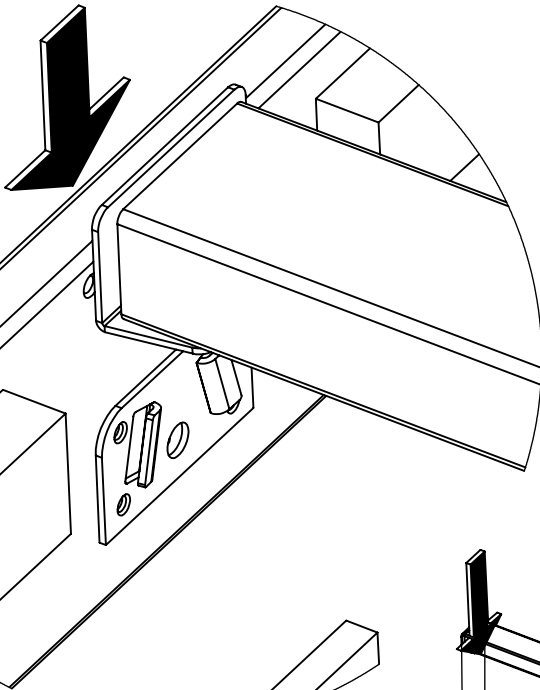

I b]ei Ya Ybhdci f`Yg\_]hgYb %&\$L% \$Z  
% \$L% \$Z% \$L&\$\$"

: ]Yn`U`hfUj YfgY `c f]ncbhU`Y`fBŁg f`YgXYi I`  
`cb[ gdUbgfBŁ": U]hYgUHYbhcb { `V]yb`]bgf fYf`  
`U`hfUj YfgY `gei flwi `ZcbX`XYg[ `]gg, fYg`"  
: ]Yf`U`hfUj YfgY`WbhfU`Y`fBŁg f`YgXYi I`  
dUbg`Wci ffgfBŁ": U]hYgUHYbhcb { `V]yb`  
]bgf fYf`U`hfUj YfgY `gei flwi `ZcbX`XYg`  
[ `]gg, fYg`"

5

9

5

8

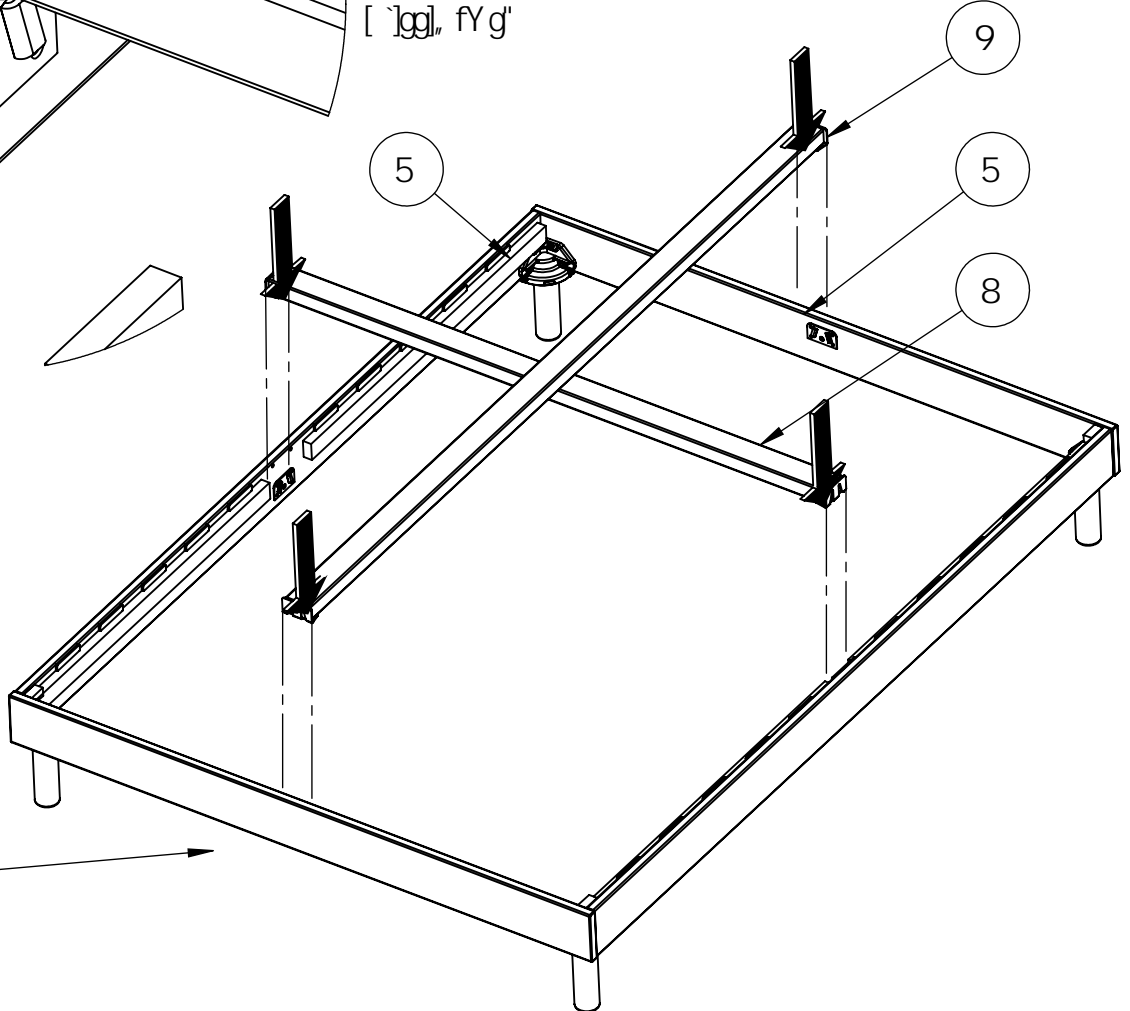

6



DcghcbbYf`Yg`UHYggj dff]i fYgflE`YbhfY`Yg`Ya Vci hgd`Ughe Yg`  
g f`Yg`cb[ gdUbgf5E`  
JffZ]YnV]Yb`ei Y`Yg`UHYggc]YbhV`cei fYgYbhfY`XYi I`Ya Vci hg`

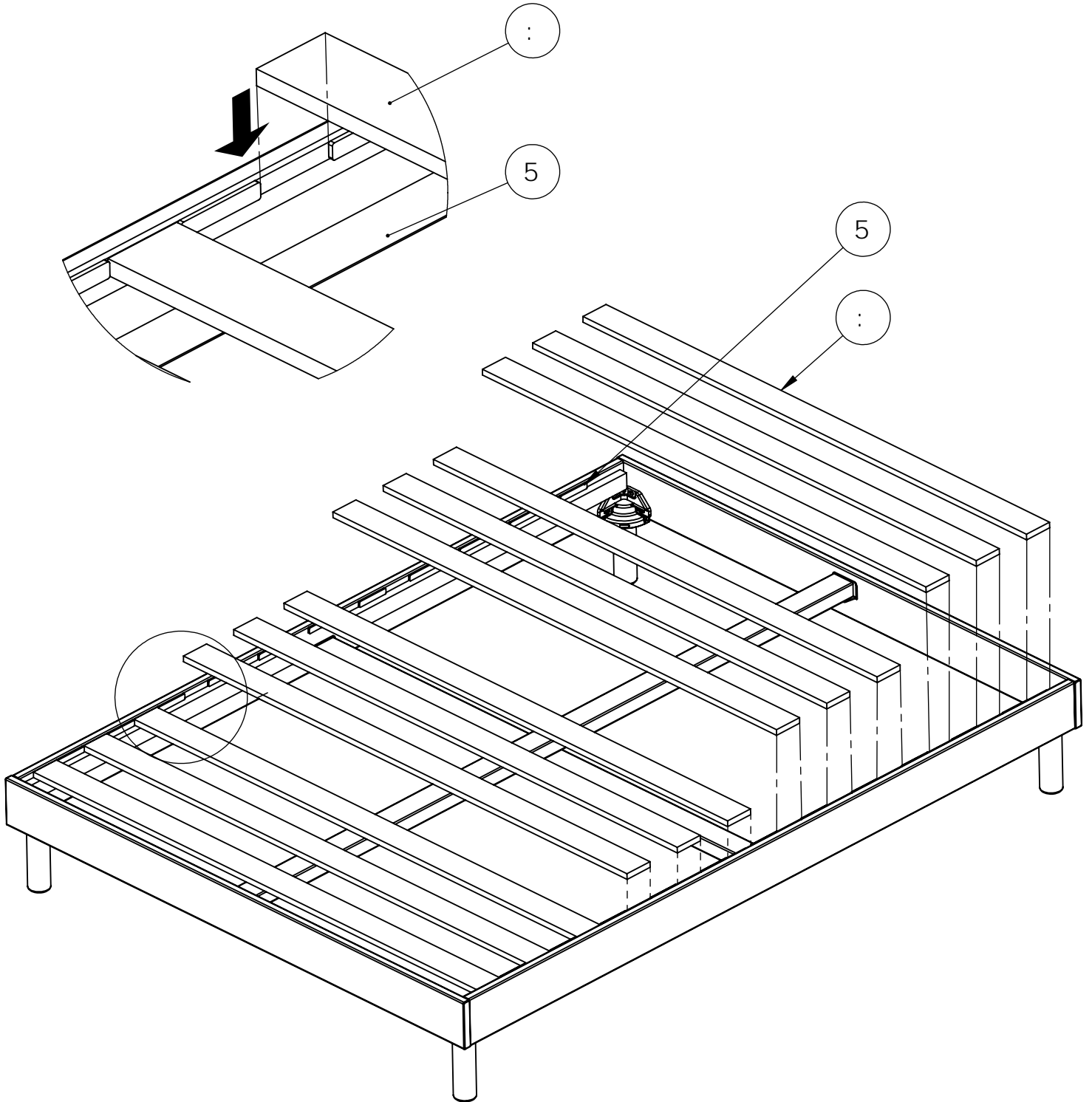

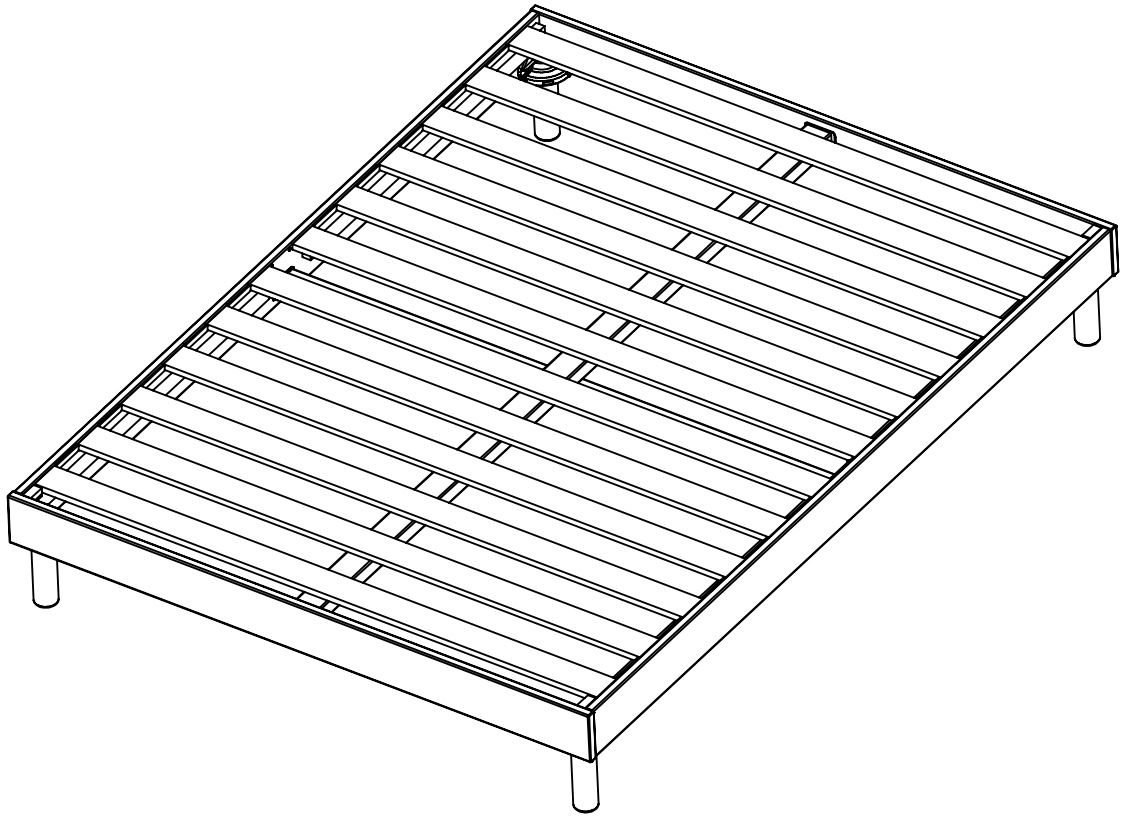

%"\$\$\$+"\$\$\$\$"&\$+