

**Nissin**  
DIGITAL

  
**NASS**  
Ready!

Compatible with  
Nissin Air System

# Di700A

for Canon/ Nikon digital SLR cameras

## INSTRUCTION MANUAL



NISSIN.JAPAN

**Changes or modifications not expressly approved by the party responsible for compliance could void the user's authority to operate the equipment.**

**This device complies with Part 15 of the FCC Rules.**

**Operation is subject to the following two conditions: (1) this device may not cause harmful interference, and (2) this device must accept any interference received, including interference that may cause undesired operation.**

## **Thank you for purchasing a Nissin product**

Before using this flash unit, please read this instruction manual and refer your camera owner's manual carefully to get a better understanding of the proper operation to enjoy flash photography.

Nissin Di700A type Canon and Nikon is designed for Canon and Nikon digital SLRs, with the latest TTL flash control system. Please note that Di700A Canon and Nikon are not usable with other branded cameras for TTL operation.

### **SPECIAL FEATURES**

The Di700A features the use of a selector dial to quickly move through all settings and can be easily operated by one finger-tip.

The Di700A with wireless flash shooting using Nissin Air System/ radio transmission.

Flash protection function:

When the red LED lamp starts blinking, it means that flash is overheating.

The LED turns red when charging.

When the LED lamp turns green, the flash is charged and you can start to shoot.

**Remark:**  Nissin Air System (NAS) is designed for Nissin flash and Nissin commander.

## **Compatible cameras**

Please refer Nissin's compatibility chart shown at its home page for details and recent updates: <http://www.nissin-japan.com> or <http://www.nissindigital.com>

# SAFETY INSTRUCTIONS

These safety instructions refer to important information on how to use this product safely and properly. Please read the following instructions before using the product.



## WARNING

This symbol refers to the possibility of personal injury, death or property damage if not followed as described.

- The flash unit contains high voltage electric parts. Do not try to open or repair the flash unit. Return it back to the repair service station or the store where you bought it from.
- Do not touch the inside parts from the opening when the unit was dropped or broken.
- Do not shoot the flash directly to the eyes at short distance. It may damage the eyes.
- When taking a flash picture, especially toward a baby, it is recommended to keep the flash unit at least 1 meter (3.3feet) away from the subject. Or use diffuser or bounce the light to the ceiling or wall to soften its intensity.
- Do not place the flash unit near any flammable gas, chemicals or such liquids. It may cause fire or electric shock.
- Do not touch the flash unit with wet hands or use in the water. The flash unit carries high voltage inside and it may cause an electric shock.
- Do not shoot the flash unit directly at the driver of automobiles or such vehicles.
- Do not set the flash window close to the human body and shoot, which may get scalded.
- Place the batteries correctly in position. Placing the batteries in wrong polarity may cause leakage, exothermic heat or explosion.



## CAUTIONS

This sign refers to conditions which may cause damage or defect.

- Do not leave or store the flash unit in the temperature over 40°C/ 104°F, such as in the automobile.
- The flash unit is not water resistance. Keep the unit away from rain, snow and humidity.
- Do not use benzene, thinner or other alcoholic agents to clean the unit.
- Do not use this flash unit with cameras which are not recommended in the compatibility list at official website, otherwise it may damage the camera's circuitry.
- Remove the batteries when not in use for a longer period of time.
- Do not have a heavy impact to the flash unit, nor throw it onto a hard surface floor.
- When using the external power pack, read the safety instructions carefully and follow the operation manual.

# Names of the Components

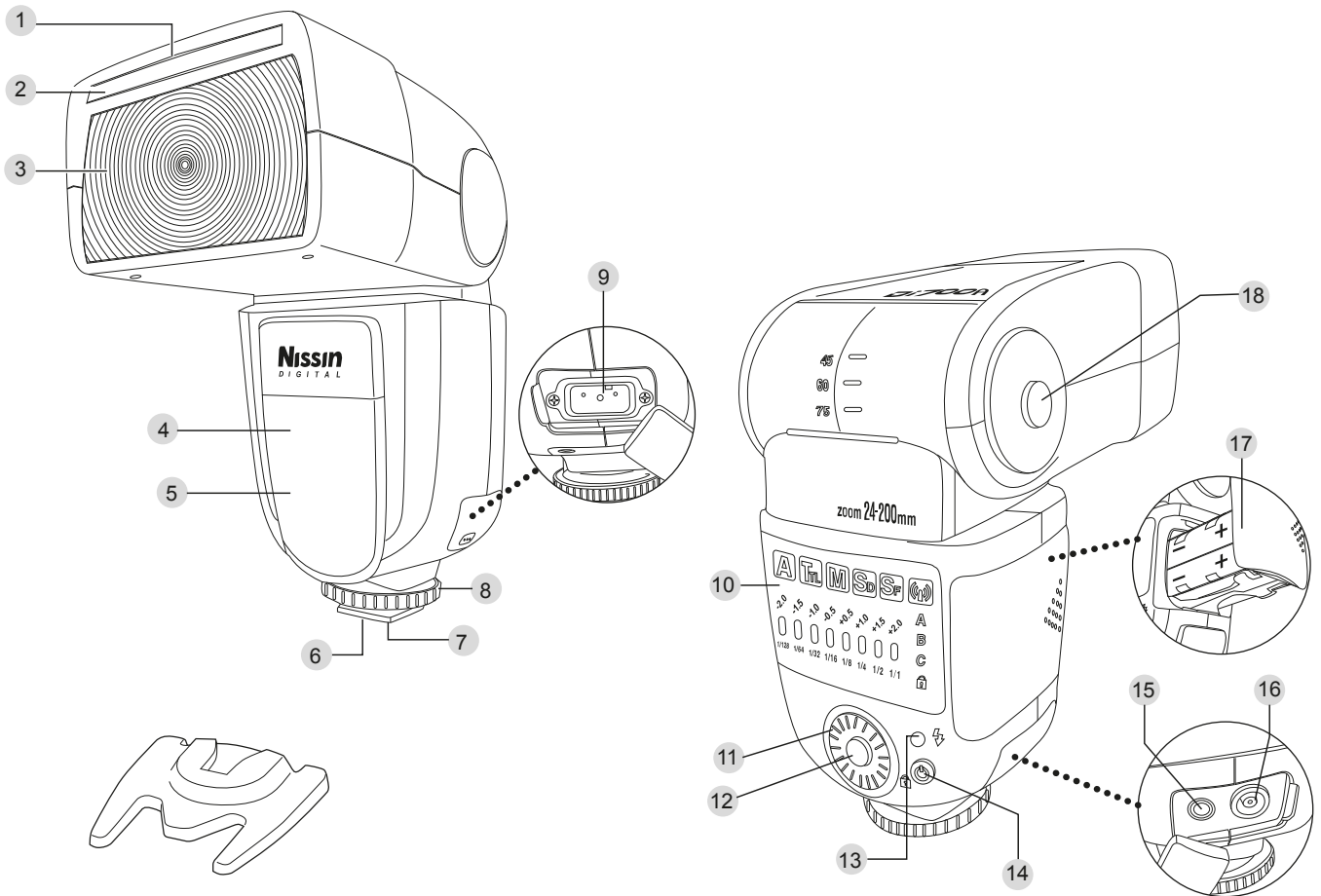

Flash stand

- |   |                       |    |                                    |
|---|-----------------------|----|------------------------------------|
| 1 | Fill-in reflector     | 10 | Display screen                     |
| 2 | Light diffusing panel | 11 | Selector dial                      |
| 3 | Flash head            | 12 | Set button                         |
| 4 | Remote/ Slave sensor  | 13 | Pilot button (Test flash button)   |
| 5 | AF-assist light       | 14 | On/Off switch (System lock button) |
| 6 | Mounting foot         | 15 | 3.5mm sync socket                  |
| 7 | Hotshoe contacts      | 16 | X-terminal                         |
| 8 | Lock ring             | 17 | Battery magazine BM-02             |
| 9 | Power Pack socket     | 18 | Rotate lock                        |

# Basic Operation

## Inserting batteries

Usable batteries - Alkaline batteries, Lithium batteries or NiMH batteries.

1. Remove the battery magazine and insert 4 x size AA batteries as shown in the picture.
2. The battery compartment is specially designed so that every battery is placed in the same direction to avoid confusion in poor lighting conditions.
3. +/- symbol is clearly marked in the battery compartment.
4. Place the battery magazine back into the body.

When the recycle time becomes longer than 30 seconds, replace the batteries with fresh ones or recharge the batteries (rechargeable batteries).

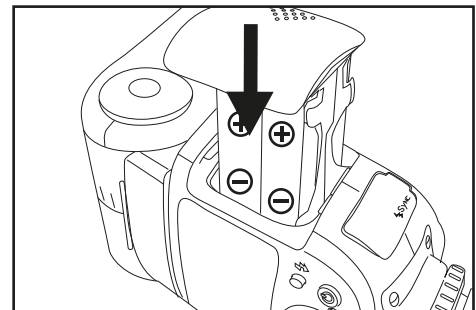
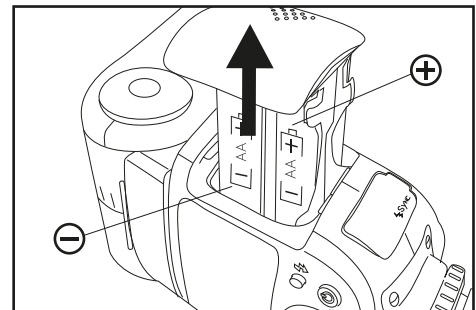
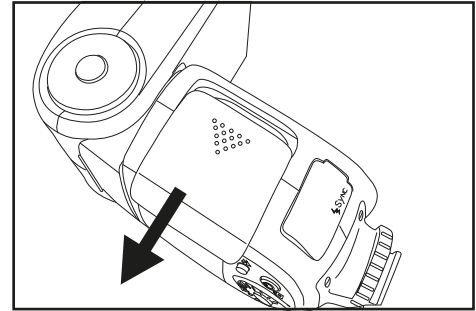

### NOTE

It is recommended to use all 4 batteries of the same brand and type, and replace them all at the same time.

Wrong insertion of each battery would not make electric contact.

## Basic Operation

### Di700A has an energy saving power off function

To save battery energy, the power is automatically turned off (switch to stand-by mode), in A mode, TTL mode & Manual Power mode, in about 2 minutes of idle use; in SD mode, SF mode & Wireless TTL Slave mode, in about 5 minutes of idle use.

While Di700A is in the stand-by mode a Pilot button blinks every 2 seconds showing the flash unit is in stand-by mode. To turn on Di700A again, press the camera's shutter button halfway or press any button of the flash unit.

In case Di700A is not in use for over 60 minutes, the unit is completely turned off.

To turn on Di700A again, take the first step of turning the flash unit on.

### Reset setup Option

Press the Set button for 5 seconds to reset the setup menu  
The flash will be automatically reset to the factory default "A" mode.

## Mounting Di700A on the camera

1. Turn off the power switch of both Di700A and the camera.
2. Turn the lock ring of Di700A to loosen it all the way as shown in the picture.
3. Slide the mounting foot of Di700A into the hotshoe of the camera.
4. Turn the lock ring in the opposite direction and tighten it.
5. Lock pin comes out to hook the foot at the hotshoe for sure contact.

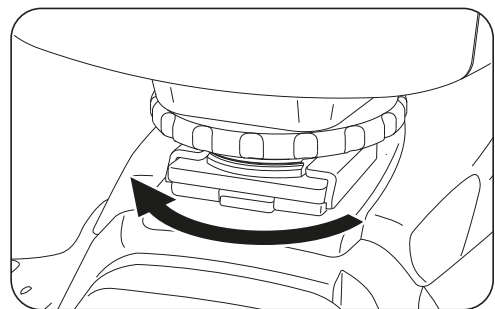
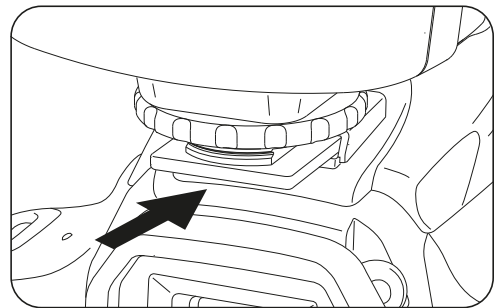
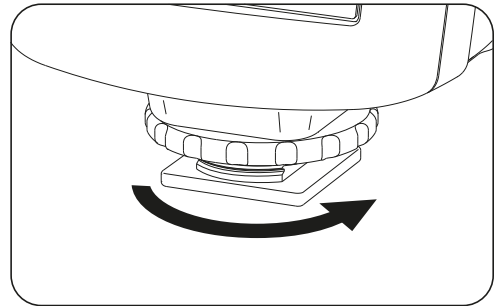

## Removing Di700A from the camera

- Loosen the lock ring and slide the mounting foot of Di700A off the hotshoe of the camera. Make sure to turn the lock ring all the way to completely clear the lock pin off the hooking slot on the hotshoe.

## Turn on the flash unit

- Press the On/ Off switch and Pilot button turns red, showing the unit is turned on.
- In a few seconds, the Pilot button turns green. The Di700A is ready to shoot.
- For a test flash, press the Pilot button. When using the test flash as an open flash, please note that the reference guide number in this case is G.No.10 (ISO 100).
- To turn off the flash unit manually, press the On/Off switch for 1 second.



## MENU SCREEN

### Di700A Flash Mode and Functions

Rotate the dial to select a function.

- A** ... Full Automatic Mode  
Flash light is fully controlled by the camera for the most proper exposure.
- TTL** ... TTL Program Mode  
Flash light is automatically controlled by the camera but the flash exposure value can be compensated.
- M** ... Manual Setting Mode  
Manual Mode -Selecting the desired manual power on the flash unit.
- SD** ... Slave Digital
- SF** ... Slave Film
- Wireless** ... Wireless TTL Slave Mode - Optical Transmission  
Placing multiple numbers of flashes (slave flash) off camera and controlling the creative TTL lighting or Manual power output.



### Wireless TTL Slave Mode - Radio Transmission (NAS)

Using a Nissin Flash (master/ slave) with a NAS shooting function makes it easy to shoot with advanced wireless multiple flash lighting, in the same way as normal E-TTL II/ E-TTL (Canon), i-TTL (Nikon) autoflash shooting.

\*For details on setting the master unit functions, see the Nissin commander's instructions.



# A

## Shooting Di700A automatically

### Canon cameras

[**P**] (Program), [**□**] (Full Auto), [**Av**] (Aperture priority), [**Tv**] (Shutter priority) or [**M**] (Manual);

### Nikon cameras

[**P**] (Program), [****] (Full Auto), [**A**] (Aperture priority), [**S**] (Shutter priority) or [**M**] (Manual);

In all of the camera's shooting modes listed above, Di700A will fully work in TTL (ETTL, ETTL-II for Canon and i-TTL for Nikon) automatic-flash system.

- Set Di700A to the camera's hotshoe and press the on/off switch to power on.
- Rotate the dial to "A" mode then press the Set button.
- Di700A is now set for the camera's automatic flash control system.
- Press the on/ off switch once again to lock this condition on your flash. (Press it again to release the lock)
- Press the shutter button of your camera halfway to focus the subject.
- Shutter speed, aperture and flash mark (  ) are indicated in camera's view finder.
- Take the picture. Di700A is fired and the result is immediately shown on the camera's LCD display.
- When you change the focal length, the power zoom flash head of Di700A responds without delay and immediately sets its position to match the lens focal length you selected.
- The flash illumination coverage of Di700A responds to the lens focal length of 24mm to 200mm (35mm film camera standard).

Set the camera's shooting mode, select focal length and take pictures with Di700A on your camera.

Di700A is a supplement to help you in taking a creative and live picture. Almost all tasks are automatically done by the camera and you just control the camera only.

| Mode   |   | Shutter Speed | Aperture Setting | Control on the camera                           |
|--------|---|---------------|------------------|---|
| Canon  | Nikon   |               |                  |   |
| [ □ ]  | [  ] | Automatic     | Automatic        | Automatic                                       |
| [ P ]  | [ P ]   | Automatic     | Automatic        | Automatic                                       |
| [ Tv ] | [ S ]   | Manual        | Automatic        | Any available shutter speed can be set          |
| [ Av ] | [ A ]   | Automatic     | Manual           | Any available f-stop can be set                 |
| [ M ]  | [ M ]   | Manual        | Manual           | Any available shutter speed / f-stop can be set |

## Synchro Terminal

Di700A is equipped with a Synchro terminal (X terminal) to connect an off-camera cable. This allows photography with flash units separate from the camera. This feature can be applied in Manual mode only.

## TTL flash power compensation

With the latest TTL flash control system, the flash power level is always automatically controlled by the camera for the most appropriate exposure. If you wish, if you can soften or weaken the flash light, or give more light to the subject without changing the environmental or background exposure effect. The Di700A can make it possible to quickly adjust the exposure for each particular flash picture as needed.

- Set Di700A to the camera's hotshoe and press the on/off switch to power on.
- Rotate the dial to "TTL" mode then press the Set button.
- To set the Flash power compensation level rotate the dial to the power level you desire.
- TTL flash power compensation is provided in 9 steps by half Ev increments for -2.0, -1.5, -1.0, -0.5, 0, +0.5, +1.0, +1.5 and +2.0 Ev.
- When Di700A shows no level indication LED turned on, the flash power compensation level is at even (0 Ev) level as default value.
- Press the on/ off switch once again to lock this condition on your flash. (Press it again to release the lock)
- Take a picture and the subject is shown with required lighting effect by keeping the background exposure level as originally expected.
- On some cameras, the TTL flash power compensation setting is provided in its menu mode. When setting the TTL flash power compensation on your camera, any compensation which is also set on the Di700A will be counted in addition to the compensation you selected in the camera's menu mode. ( i.e. Having a +1 compensation set on the flash and a +1.3 compensation set in the camera would yield a total compensation of +2.3 EV.)

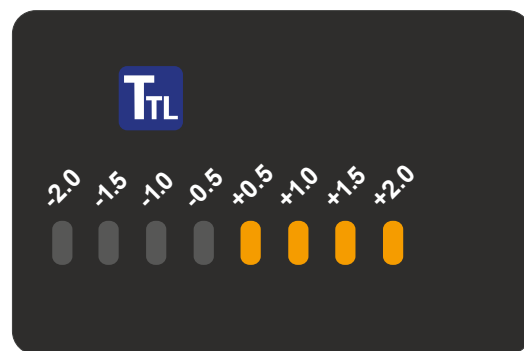

# M

## Manual Exposure Flash

In some occasions, or for special expression, you may need your own flash exposure instead of the automatic controlled exposure. You can set Di700A for non-automatic flash mode, and select the desired flash power from 8 different levels

- Set Di700A to the camera's hotshoe and press the on/off switch to power on.
- Rotate the dial to "M" mode then press the Set button.
- You can select the power by rotating the dial, from the left to right, 1/128 – 1/64 – 1/32 – 1/16 – 1/8 – 1/4 – 1/2 – 1/1 (Full) power.
- Press the on/ off switch once again to lock this condition on your flash. (Press it again to release the lock)
- Set the camera shooting mode to either [ AV ](Canon), [ A ](Nikon) or [ M ].
- Select your desired F--stop and / or shutter speed. Point the subject and press the shutter.

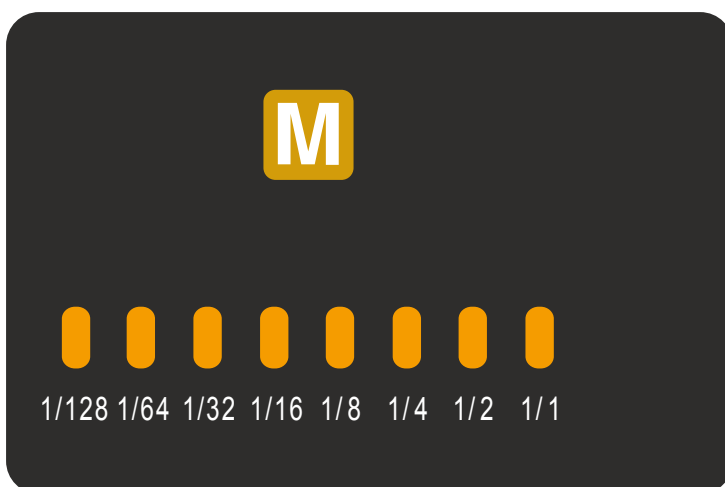



## Wireless Slave Flash

Di700A has a wireless remote flash system as a slave unit. You can enjoy creative flash photography with multiple lightings from the various directions. 3 slave modes are provided, Slave Digital (SD) for digital pre-flash system; Slave Film (SF) for analogue flash system and Wireless TTL slave (Ⓜ) for wireless remote. All channels and groups A/B/C may be used.

**SD:** In this mode, Di700A synchronizes to the pre-flash system. The master flash is to be set at TTL (E-TTL for Canon, i-TTL for Nikon) mode.

- You can select the power by rotating the dial, from the left to right, 1/128 – 1/64 – 1/32 – 1/16 – 1/8 – 1/4 – 1/2 – 1/1 (Full) power.
- Press the on/ off switch once to lock this condition on your flash. (Press it again to release the lock)

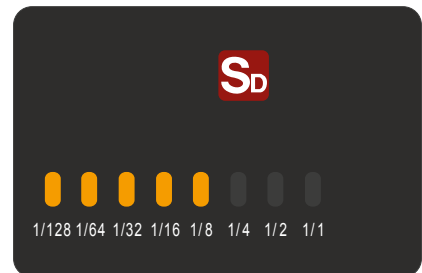

**SF:** In this mode, Di700A synchronizes to the traditional single flash system. The master flash is to be set at manual mode. Studio lighting system synchronizes to this mode. This mode is also available for open flash, and for a standard flash in the market.

- You can select the power by rotating the dial, from the left to right, 1/128 – 1/64 – 1/32 – 1/16 – 1/8 – 1/4 – 1/2 – 1/1 (Full) power.
- Press the on/ off switch once to lock this condition on your flash. (Press it again to release the lock)

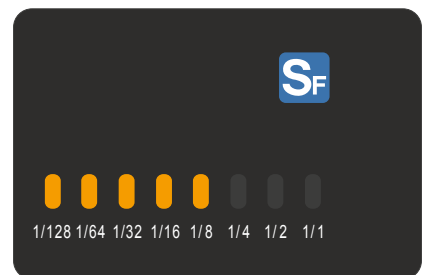

### Wireless TTL Slave - Optical

**Transmission :** For Canon and Nikon systems: In this mode, Di700A synchronizes to the wireless remote flash system. For remote All channel group A/B/C digital flash.

- You can select the group by rotating the dial then press Set button.
- Press the on/ off switch once to lock this condition on your flash. (Press it again to release the lock)
- Press the Set button to leave the group.





## Wireless Slave Flash

**Wireless TTL Slave - Radio Transmission (NAS)**  : For Canon and Nikon systems: In this mode, Di700A synchronizes to the wireless remote flash system. For remote All channel group A/B/C digital flash.

Using Di700A with a NAS shooting function makes it easy to shoot with advanced wireless multiple flash lighting, in the same way as normal E-TTL II/ E-TTL/ i-TTL autoflash shooting.

Once Di700A linked to NAS, function are control directly by the NAS master. User only need to select the group on Di700A

- You can select the group by rotating the dial then press the Set button.
- Press the on/ off switch once to lock this condition on your flash. (Press it again to release the lock)
- To leave the group, press the Set button.

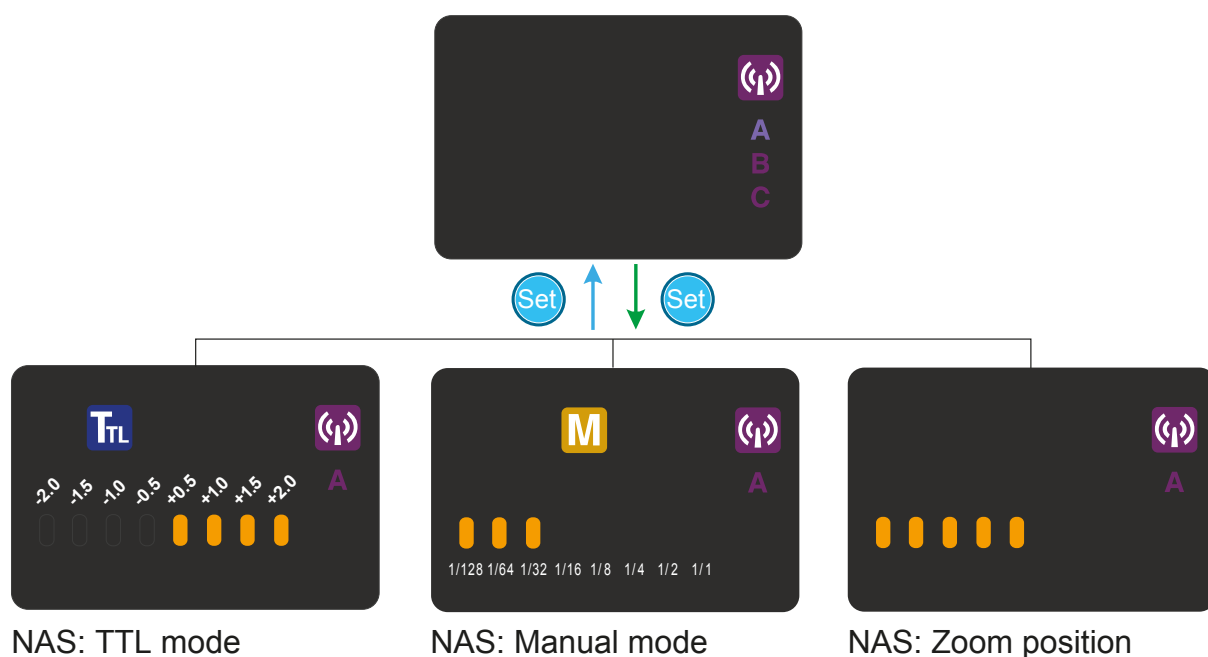

### NOTE

The Nissin commander attached to the camera is called master unit. When a NAS master is on, Di700A will automatically set to radio transmission mode. Otherwise the Di700A will automatically set to Optical Transmission.

## Setting slave flash Di700A

- Switch Di700A on and while the ready lamp is on, rotate the dial and press Set button to select desired mode.
- When flash is set to SD or SF mode, the of flash power level is indicated by the lighted LED's. Rotate the dial to select different flash power levels of 1/128 – 1/64 – 1/32 – 1/16 – 1/8 – 1/4 – 1/2 – 1/1 (Full) power.
- The power you selected is memorized and remains unchanged.
- When the flash is set to the Wireless mode, the power level will be controlled by the Master flash. The remote works on all channels and with group A/B/C.
- Set slave flash at any place and direct the flash head as you desire. Slave sensor may not respond to the master flash in a poor sensing situation such as extremely bright condition.
- Use the flash stand included. Place Di700A on to the flash stand which can be placed either on a flat surface, or on the tripod by the screw.

### NOTE

Metal type accessory shoe is not recommended since it may give electric damage on the electrical contact of the flash hotshoe.

## Shooting the subject

Set the camera for flash shooting mode. Point at the subject and shoot. The slave flash will synchronize to the master flash and gives additional lighting from the different direction you desired.

Energy saving system for stand-by mode will not work when it's in slave mode.

Automatic shut off function is however in effect. It automatically turns-off when not in use for over 60 minutes.

The zoom setting position is automatically set for the focal length of 35mm while using Di700A as a slave unit.

To reset the flash unit to another mode, press the mode select button for TTL and or Manual mode.

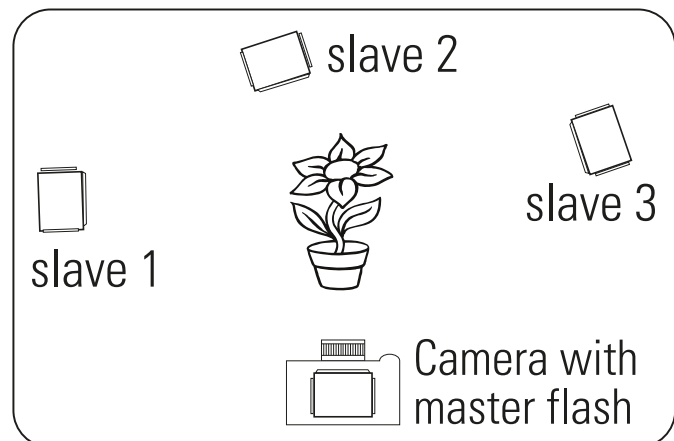

## HSS High-Speed Synchronization

- Di700A supports shutter speeds up to 1/8,000 second.
- High-speed Sync: In A, M, TTL, Wireless mode.
- Enable HSS (Canon)/ Auto FP (Nikon) function on camera body.
- For set up details please refer to Camera operation Manual.
- High-speed mode use higher flash energy. To protect the flash from overheat. The recycling time will be extended to a minimum 7 seconds.



## Fill-in flash and Light diffusing panel

For short distance or portrait flash photography, if the light is not too sharp or too strong to the subject. Use fill-in reflector flash or diffuse the light.

- If the subject is close (within 2 meters), turn the flash head 90° upward and pull out the fill-in reflector as shown in the picture.
- Take a picture as usual. A blink of fill-in flash freshens up the subject in natural image.
- This small blink of flash is also useful when taking a picture of a baby without scaring him.
- This technology is also useful to eliminate the shadow on the subject under the tree.

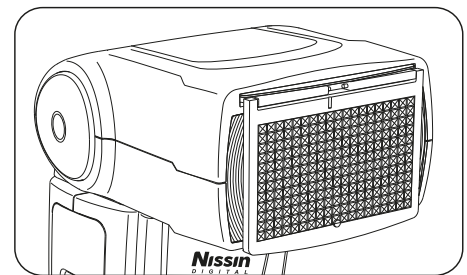
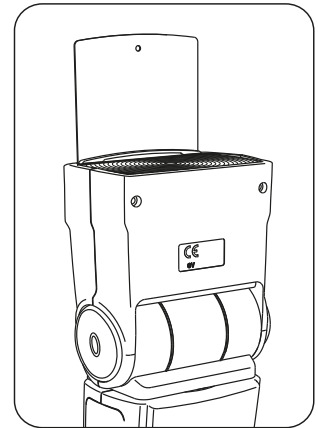

- For portrait photography, pull out the light diffusing panel and place it over the flash window as shown in the picture. The diffusing panel makes the flash light soften and creates a lively color effect on the subject.



- Since the light diffusing panel expands the lighting area, it covers the range of 16mm focal length lens.

## Bounce lighting

When lighting a subject in front of the wall, an unnecessary sharp shadow may appear on the wall behind the subject resulting in a disappointing picture. Bounce the light off the ceiling or wall to soften the light on the subject, and the shadow will fade.

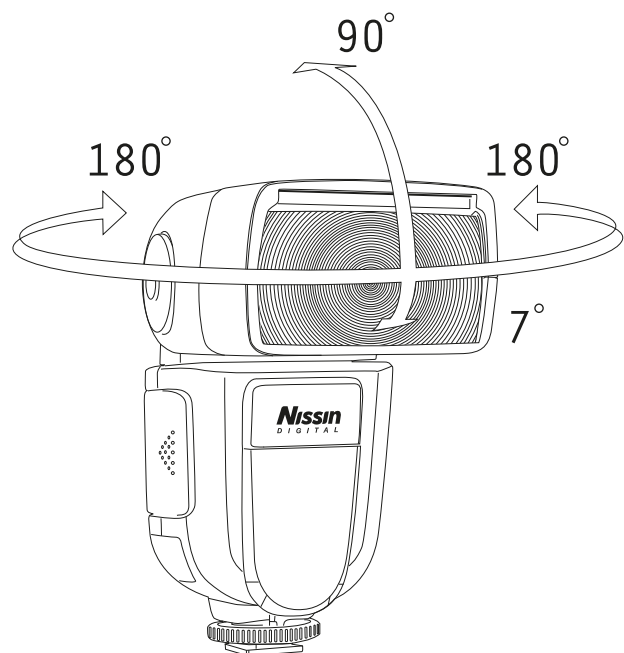

- Press the rotate lock to turn the flash head up and down. It turns upward to 45° >60° >75° >90° and downward to 7°
- Press the rotate lock to tilt the flash head sideways to left 30° >60° >90° >120° >150° >180° or to right 30° >60° >90° >120° >150° >180°.
- Or mixing it upward/downward/ sideways, you can set it in multiple directions as shown.
- When the flash head stays at turning or tilting position, the zoom setting position of Di700A is automatically set at the position for a 50mm focal length lens.
- The wall or ceiling in this case should be a flat surface and white color is preferable. Colored ceiling or wall may reflect its color on the subject.

## AF assist light emitter

Under a low light condition, or in a dark place, the AF assist light will automatically emit the beam and illuminate the subject, so that the camera can easily focus on the subject in darkness. The beam is however not shown in the picture.

## External Power Pack Socket

When using an external power source, the number of flashes is increased and the recycling time is shortened. The following external power packs are available as an option.



| Battery = NiMH battery  | Recycle time                            |
|-------------------------|---|
| Nissin Power Pack PS 8  | 0.8 seconds                             |
| Nissin Power Pack PS300 | 0.8 seconds                             |
| Canon CP-E4             | about 2 seconds                         |
| Nikon SD-8A/ SD-9       | 3.8 seconds (SD-8A)<br>2 seconds (SD-9) |

Di700A is automatically turned off when repeating flash continuously over 20 to 30 times to protect the flash circuitry from overheating. It will automatically recover after 15 minutes of inactivity. The pilot button will blink in the red color every 1.5 seconds.

Please note that the basic operation is controlled by the main batteries(battery magazine) in the flash unit and when the main batteries are exhausted, the flash control system does not work. Replace the batteries when recycle time becomes longer than 30 seconds by main batteries only.

## Flash Power Lock

When the back ground of the main subject is too bright, the camera's exposure reading system adjusts the flash light intensity for such back ground condition and it results in the main subject being underexposed. Or in case the main subject is not placed in the center of the viewfinder, the flash picture may result in the aimed targeted subject being under or over exposed.

You can lock the correct flash exposure for the targeted subject in such a condition. This flash exposure pre-set remains locked in, even if you change the aperture or zoom the lens in and out. This mode can only be set on the camera.

With Canon cameras: FE lock

- Focus the subject.
- Aim the viewfinder center over the main subject and press [\*] button on the camera (or [FEL] button on some cameras).
- Pre-flash is fired to pre-set the correct light amount for the main subject.

Remarks: FEL only works on P, TV, AV, M & A-Dep mode.

(It depends on different type of camera, please check you camera instruction manual.)

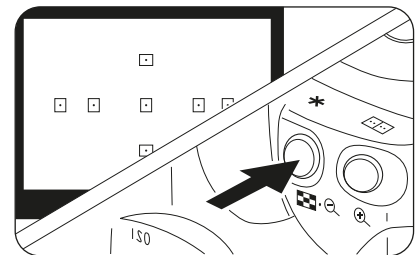

With Nikon cameras: Fv lock

- Set the Fv lock mode at the menu on your camera.
- Focus the subject.
- Aim the viewfinder center over the main subject and press [AE-L] button on the camera (or [AF-L] button on some cameras).
- Set the picture frame as you desire and release the shutter.

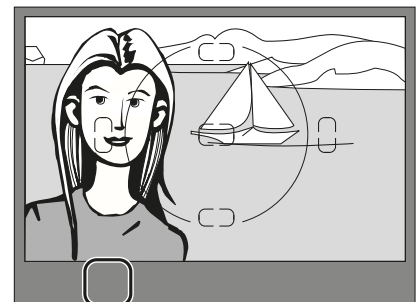

(It depends on different type of camera, please check you camera instruction manual.)

## For Nikon Version only

Following functions are available on Nikon cameras.  
Refer to camera owner's manual for details.

### Slow shutter synchronization

The flash is controlled at a slow shutter speed to the correct exposure for both the main subject and background in low light conditions or at night.

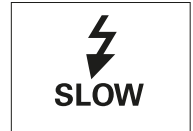

### Red-eye reduction

To prevent the subject's eyes from appearing red, Di700A fires three controlled flashes just before the picture is taken. Red-eye reduction can be combined with slow sync.

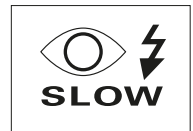
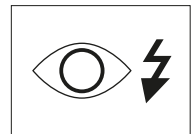

### Rear curtain synchronization

In rear-curtain sync., the flash fires just before the rear curtain closes. By using this function at slow shutter speeds, a moving subject will appear with such moving marks behind.



## Specifications

|                                |  |
|--------------------------------|--|
| Type                           | for Canon and Nikon Digital SLR cameras  |
| Guide no. (at ISO 100 in m)    | GN54 (at 200mm zoom head position)/<br>GN48 (at 105mm zoom head position)  |
| Focal length coverage          | 24 - 200mm<br>(16mm when using built-in wide panel)  |
| Power Source                   | 4 x LR6 batteries<br>(Size AA Ni-MH or lithium batteries usable)   |
| Battery loading system         | Quick loading – Battery Magazine BM-02   |
| Recycling Time                 | about 5 seconds  |
| Number of flashes (Approx.)    | 200 - 1500 flashes   |
| Flash duration                 | 1/800 - 1/30,000 Sec   |
| Color Temperature              | 5,600k   |
| Exposure control               | E-TTL II/ E-TTL (Canon) and i-TTL (Nikon)  |
| Wireless Mode                  | Wireless TTL Slave: Optical Transmission and<br>Radio transmission (NAS).<br>Non-TTL Slave (SD mode and SF mode)   |
| TTL compensation on flash      | -2 to +2 EV in increments of 1/2 EV  |
| Bounce position                | Up: 90°, Down: 7°, Left: 180°, Right 180°<br>(with flash head tilting/ rotating lock release button)   |
| Flash exposure control         | 1st -Curtain synchronization, 2nd-Curtain<br>synchronization, High-speed synchronization,<br>Red-eye reduction, Slow synchronization<br>(only available on Nikon Model),<br>FE / FV Lock (set on camera) |
| AF-assist beam effective range | 0.7 – 6m/ 2.3 – 19.7 feet  |
| Operation panel                | Color display panel (LED), selector dial   |
| External service ports         | External power source socket, PC terminal,<br>3.5mm sync socket  |
| External Power Pack            | Service socket for the external power pack<br>(optional accessory)<br>Nissin Power Power Pack PS300/ PS 8  |
| Accessories                    | Soft case, flash stand (with screw)  |
| Dimensions                     | 140(H) x 75(W) x 115(D) mm/<br>5.5(H) x 3(W) x 4.5(D) inches   |
| Weight                         | 381g/ 13.4oz (without batteries)   |

## Guide Numer table

Guide No. at manual exposure mode (ISO 100 in meters)

| Zooming Position | Flash Power Level |     |     |     |      |      |      |       |
|------------------|-------------------|-----|-----|-----|------|------|------|-------|
|                  | Full              | 1/2 | 1/4 | 1/8 | 1/16 | 1/32 | 1/64 | 1/128 |
| 24mm             | 22                | 15  | 11  | 8   | 5    | 4    | 3    | 2     |
| 28mm             | 25                | 18  | 13  | 9   | 6    | 4    | 3    | 2     |
| 35mm             | 28                | 20  | 14  | 10  | 7    | 5    | 4    | 3     |
| 50mm             | 32                | 22  | 16  | 11  | 8    | 6    | 4    | 3     |
| 70mm             | 41                | 29  | 21  | 15  | 10   | 7    | 5    | 4     |
| 85mm             | 47                | 33  | 23  | 16  | 12   | 8    | 6    | 4     |
| 105mm            | 48                | 34  | 24  | 17  | 12   | 9    | 6    | 4     |
| 135mm            | 49                | 35  | 25  | 17  | 12   | 9    | 6    | 4     |
| 200mm            | 54                | 38  | 27  | 19  | 14   | 10   | 7    | 5     |

## Trouble Shooting

### **The flash unit does not start charging.**

- Batteries are not correctly installed  
>>> Install batteries to correct direction.
- Batteries are exhausted  
>>> Replace the batteries if the recycle time is beyond 30 seconds.

### **The flash unit does not fire.**

- The flash unit is not firmly clipped on the camera  
>>> Mount the flash unit firmly on the camera's hot shoe.
- The flash unit is automatically powered off  
>>> Turn on the switch again.

The flash picture is overexposed or underexposed.

- A reflective object or strong lighting is near the subject  
>>> Use FE or Fv lock.
- The unit is set for manual exposure mode  
>>> Set to TTL mode or other power level.

# Warranty

In case of the following reason of the defect, it may void the warranty. Please refer the respective warranty condition for details which depends on the country of purchase.

1. The product is not used in accordance with the instruction of the owner's manual.
2. The product is repaired or modified by the one who is not an authorized repair service.
3. When the product is used with the cameras not applicable, lens, adaptors or such accessories produced by the third party.
4. Fault or defect caused by fire, earthquake, flood, public pollution and such natural accident.
5. In case that the product is stored in dust, moisture, extremely high temperature or such poor condition.
6. Scratch, blemish, crush or worn out by a violent use or treatment.
7. Guarantee card without name of place purchased or date of purchase stamped, or no guarantee card.



***Nissin***

Nissin Japan Ltd., Tokyo  
<http://www.nissin-japan.com>

Nissin Marketing Ltd., Hong Kong  
<http://www.nissindigital.com>