



**New EU Toys Directive
(2009/48/EC)**

TECHNICAL FILE

Item No. : 56217

Item Name: My First Frame Pool

Prepared by: Kyrie

Date: 2016-7-14

Checked by: Mi. Huang

Date: 2016-7-14

Table of Contents

1 Declaration of Conformity	3
2 Risk Assessment	5
3 BOM	10
4 Scheme of Components and Subassemblies.....	11
5 MSDS.....	ANNEX A
6 Test Report.....	ANNEX B
7 Internal Production Control and Quality Assurance Procedure.....	ANNEX C
8 The Print of the Packaging	ANNEX D
9 Instruction.....	ANNEX E



DECLARATION OF CONFORMITY

We, the Manufacturer

Bestway (Europe) s.r.l.,

Via Resistenza, 5, 20098 San Giuliano Milanese (Milano), Italy



declare with all responsibility that the products:

Model No. 56217

Model Name: My First Frame Pool

Product Description:

- * Easy set up*
- * Rust-resistant metal frames*
- * Easy to take down for off-season storage*
- * 3 assorted colors*
- * Heavy-duty repair patch*
- * Full color box*



is in conformity with follow European directives

2009/48/EC Directive on the safety of toys

Conformity with the requirements of above Directives is testified by complete adherence to the following harmonized standards

EN 71-1:2014

EN 71-2:2011+A1:2014



EN 71-3:2013+A1:2014

EN 71-8:2011

The product of the declaration described above is in conformity with the requirements of the following specifications / test reports:

Test Report No. **SHTY150400006117; SHTY150400006114-01**

issued by: **SGS-CSTC STANDARDS TECHNICAL SERVICES (SHANGHAI) CO.,LTD**

Signed for and on behalf of:

Place: Via Resistenza, 5, 20098 San Giuliano Milanese (Milano), Italy

Date: 2016-06

Name: Mi Huang

Function: Certification Engineer

Signature:

PRODUCT RISK ASSESSMENT

SECTION 1 – Description

Item/Concept Name:	56217		
Detailed Description:	My First Frame Pool		
Materials Used:	PVC		
Age Grading:	Over 2 years		



Executive Summary

SECTION 2 – Applicable Standards

Product Category	Toy
Applicable Standards	<p>US</p> <p>ASTM F963 Standard Consumer Safety Specification for Toy Safety / CPSC</p> <ul style="list-style-type: none"> - Physical & Mechanical Test - Flammability Test - Total Lead Content (coating) <p><i>Effective Date: 90 ppm requirement is effective one year after the date of enactment or August 14, 2009.</i></p> <p>ASTM F963 Standard Consumer Safety Specification for Toy Safety</p> <ul style="list-style-type: none"> - Soluble Migrated Elements (coating) <p><i>Under the terms of the Consumer Product Safety Improvement Act (CPSIA), ASTM-F963 became a federally mandated safety specification on February 10, 2009.</i></p>

	<p>Consumer Product Safety Improvement Act (CPSIA)</p> <ul style="list-style-type: none"> - Section 108 - Phthalates Content (DEHP, DINP, DIDP, DBP, BBP & DNOP) - Section 101 - Total Lead in Substrate <p><i>Effective Date: 300 ppm requirement is effective one year after the date of enactment or August 14, 2009. The limit goes down to 100 ppm after three years, or August 14, 2011, unless the Commission determines that it is not technologically feasible to have this lower limit.</i></p> <p>Federal Communications Commission (FCC) Part 15 Verification</p> <p>Coalition of Northeastern Governors (CONEG) / Toxics in Packaging Clearinghouse (TPCH) – Heavy Elements (Pb + Cd + Hg + Cr VI) in Packaging</p> <p>EU</p> <p>Toy Directive (2009/48/EC)</p> <ul style="list-style-type: none"> EN 71-1 Safety of toys - Mechanical and physical properties EN 71-2 Safety of toys - Flammability EN 71-3 Safety of toys - Migration of certain elements EN71-8 Safety of toys - Swings, slides and similar activity toys for indoor and outdoor family domestic use <p>EN 71-9 Safety of toys – Organic chemical compounds</p> <ul style="list-style-type: none"> Monomers Solvent Migration Plasticizers <p><i>The item will need to comply with EN71 Parts 9, 10 and 11(Organic Chemical Compounds) when they are published in the Official Journal of the EU</i></p> <p>Phthalates Directive (DEHP, DINP, DIDP, DBP, BBP & DNOP) (2005/84/EC)</p> <p>Cadmium Directive (91/338/EEC)</p> <p>Benzene (82/806/EEC)</p> <p>Toluene (2005/59/EC)</p> <p>PentaBDE / OctaBDE (2003/11/EC)</p> <p>Organotin (2009/425/EC)</p> <p><i>Effective Date: July,2010</i></p> <p>REACH (EC 1907/2006)</p> <p>Packaging Waste Directive (Pb + Cd + Hg + Cr VI) (94/62/EC)</p> <p><i>The requirements listed above represent our best efforts to include the applicable requirements for the countries in which these products will be distributed.</i></p>
Other Test Recommendations	<p>US California Proposition 65 Phthalates (DEHP, BBP, DBP, DIDP & <u>DnHP</u>)</p> <p>German Polycyclic Aromatic Hydrocarbons (PAHs)</p> <p>German DIN 53160 Colourfastness to Perspiration and Saliva</p> <p><i>The requirements listed above do not cover possible additional national Member States (EU) legislation and Individual States (US) Regulation.</i></p>

SECTION 3 – Product Design Evaluation

Compliance Findings	<p>US</p> <p>The product should comply with the requirements for children more than 24 months based on the play feature, construction and design.</p> <p>Non-conformity was not identified during this review, but the following requirements should be noted,</p> <ul style="list-style-type: none"> ▪ There shall be free of sharp point before and after abuse testing
---------------------	---

	<p>Europe The product should comply with the requirements for children more than 24 months based on the play feature, construction and design.</p> <p>Non-conformity was not identified during this review, but the following requirements should be noted,</p> <ul style="list-style-type: none"> ▪ The stopper shall be capable of being pushed into the toy so that it does not stand more than 5 mm from the surface of the toy ▪ The stopper, if detached when tested according to torque and tension test according to EN 71-1, it shall not be small part. <p>Note: Above compliance requirement is checked according to the physical and mechanical hazard only.</p>
--	---

Risk Assessment Findings:	
<p>Physical/mechanical risk Risk level-Low</p>	<p>Fall/Impact Children may play with the pool by inappropriate way which was not designed for. Children may jump into/out from the swimming pool and it may pose fall hazard to children. The risk of this hazard is increased because of wet and slippery surface. This hazard is coherent to all inflatable pools and there is no special feature showed it would increase the risk.</p> <p>Drowning The inflatable pool may pose drowning hazard to children without adult supervision. The risk of this hazard is slightly reduced because of providing warning. This hazard is coherent to all inflatable pools and there is no special feature showed it would increase the risk.</p> <p>The warning shall be clearly visible by the supervising adult during use of the paddling pool.</p>
<p>Chemical risk Risk level-Low</p>	<p>Dermal exposure During the period of playing with the toy, plastic components could come into direct short-term repetitive contact with human skin, under normal or reasonably foreseeable use. Some chemical substances may cause slightly allergic or irritant after exposure.</p> <p>Oral exposure Children may put the toy or other detachable component into their mouth for licking, sucking or swallowing .</p> <p>This assessment would focus on assessing the likelihood of the presence of hazardous substances in toy materials that are prohibited or restricted for the use in standards and directives such as under the Toy Safety Directive (TSD) (2009/48/EC) and REACH (Regulation (EC) No 1907/2006 and its amendments).</p>
<p>Flammability Risk level-Low</p>	<p>Selecting non-flammable materials or reduce the flammability, but not prohibited or restricted flame-retardant additives. The toy shall not contains flammable liquid and the flash point shall be control > 60 °C.</p>
<p>Radioactivity</p>	<p>Declaring that radioactive materials have not been intentionally added and compliance to Chapter III (Health protection from radiation) of the treaty establishing the European Atomic Community.</p>
<p>Hygiene</p>	<p>Toy has to be designed and manufactured in such a way that they can be cleaned. Cleaning here means removing impurities or dirt from the toy in general. The maintenance instructions shall include how to clean. Water remained in the pool could be contaminated after play may induce bacterial growth, the below labeling is recommended "Dried and Emptied the toy after use."</p>
<p>Critical Manufacturing Concerns</p>	<p>Heavy elements content of incoming paints and raw materials should be controlled, especially lead in paint and Phthalates, which are involved large number of US CPSC and RAPEX recall cases.</p> <p>Mould flash and process burrs should be controlled throughout production in order</p>

to minimize the laceration hazard from sharp points or edges on the items.

SECTION 4 – Labelling Requirements

CE Mark Required?	Yes for EU (in correct format)
Labelling on the item	<p>All texts required shall be written in the official language of the country in which the toy is to be sold.</p> <p>US ASTM F963 Standard Consumer Safety Specification for Toy Safety Either a principal component of a toy or the package of a toy shall be marked with the name and address of the producer or the distributor (clause 7.1)</p> <p>Consumer Product Safety Improvement Act (CPSIA) Tracking Labels for Children's Products (Section 103(a)) The tracking label must contain certain basic information, including the source of the product, the date of manufacture and more detailed information on the manufacturing process such as a batch or run number. A label stating only the date of distribution, production date and trademark information would not satisfy the requirements of section 103. Such a label would lack information identifying the manufacturer or private labeller, the place of production and cohort information. The law requires that markings with the specified information be permanent. Hangtags and adhesive labels are not permanent.</p> <p>EU The CE marking must be affixed to the product or to its data plate. The CE marking must be affixed visibly, legibly and indelibly.</p>
Labelling on the packaging	<p>All texts required shall be written in the official language of the country in which the toy is to be sold.</p> <p>US ASTM F963 Standard Consumer Safety Specification for Toy Safety Either a principal component of a toy or the package of a toy shall be marked with the name and address of the producer or the distributor (clause 7.1)</p> <p>19 CFR 134 Country of Origin Marking Consumer Product Safety Improvement Act (CPSIA) Tracking Labels for Children's Products (Section 103(a)) The tracking label must contain certain basic information, including the source of the product, the date of manufacture and more detailed information on the manufacturing process such as a batch or run number. A label stating only the date of distribution, production date and trademark information would not satisfy the requirements of section 103. Such a label would lack information identifying the manufacturer or private labeller, the place of production and cohort information. The law requires that markings with the specified information be permanent. Hangtags and adhesive labels are not permanent. <i>Effective Date: The requirement for tracking labels is effective one year after the date of enactment or August 14, 2009.</i></p> <p>EU EN 71-1 Safety of toys - Mechanical and physical properties The manufacturer or his authorized representative or the importer into the community shall in a visible, easily legible and indelible form affix his name and/or trade name and/or mark and address on the toy packaging together with the CE-marking. (clause 7.1 & 2009/48/EC New Toys Safety Directive)</p>



Supporting Risk Assessment Documentation

SECTION 5 – Relevant Data Analysis Findings

US Consumer Product Safety Commission (CPSC) Recalls

Inflatable Toys

There is a recall of inflatable toy related to choking hazard. The inflator plug was detached from the toy and presents a potential choking hazard to young children.

EU RAPEX Recalls

Inflatable Toy and Pool

There are significant numbers of RAPEX recalls of inflated toys and pools, due to part which could cause excessive phthalates. There are some recall cases because of the detaching inflator plug and posing choking hazard.

US NEISS (National Electronic Injury Surveillance System) Injury Database

A detailed injury data analysis was conducted to determine if any hazards may exist related to the pull toy. The CPSC NIESS data, Incident Reports and Death Certificate Files for the years 1980-2006 were reviewed looking for specific injuries caused by items with the characteristics of the item under review.

Wading Pools

A total of 633 incidents were identified in the CPSC NEISS data, Incident Reports and Death Certificate Files for product code 1246 [Wading Pools] for children up to age 14. This data was reviewed to determine how many injuries were caused by toys with similar characteristics to inflatable pools. Examination of these showed that the predominant cause of injury was due to falling hazard while children leaving / entering to the inflatable pool.

Conclusion:

Although the data indicates a number of injuries and a number of fatalities involving inflatable pool and toy, given the exposure of these items to the population it is thought that there may be a relatively low probability of injury resulting from their use and that injuries may be unlikely to be severe.

BOM (Bill of Materials)

Product Name : My First Frame Pool					
Date : 2016-4-27					
Item No :56217					
Description or level number	Part Number	Number Used (g)	Material, Substance, Component	CAS or Einecs	MSDS Required Y/N
WATER PLUG	1	7	PVC 60.4%	9002-86-2	Y
			DOTP 36.2%	6422-86-2	Y
			ESO 1.8%	8013-7-8	Y
			Organic Tin compounds Heat Stabilizer 0.6%	13463-67-7	Y
			Barium zinc Heat Stabilizer 1.0%	/	Y
BLUE PVC SHEET	2	1220(3660)	PVC 60.3%	9002-86-2	Y
WHITE PVC SHEET			6422-86-2	Y	
ORANGE PVC SHEET			8013-7-8	N	
GREEN PVC SHEET			/	Y	
STEM WATER(FYF005)			3	24.34908	
500#BLACK OIL(FYB016)	4	0.65448	Polymerization of the prepolymer 50%	/	N
M4910/M6910/403#PURPLE/GREEN/BLUE OIL(FYB037/036/012)		10.54238	photosensitive monomer 30%	/	N
104#WHITE OIL(FYB002)		11.19282	photoinitiator 15%	/	N
408#BLUE OIL(FYJ014)		0.65448	pigments 5%	/	N
302#RED OIL(FYB007)		0.65448		/	N
33498#ORANGE OIL(FYB029)		0.65448		/	N

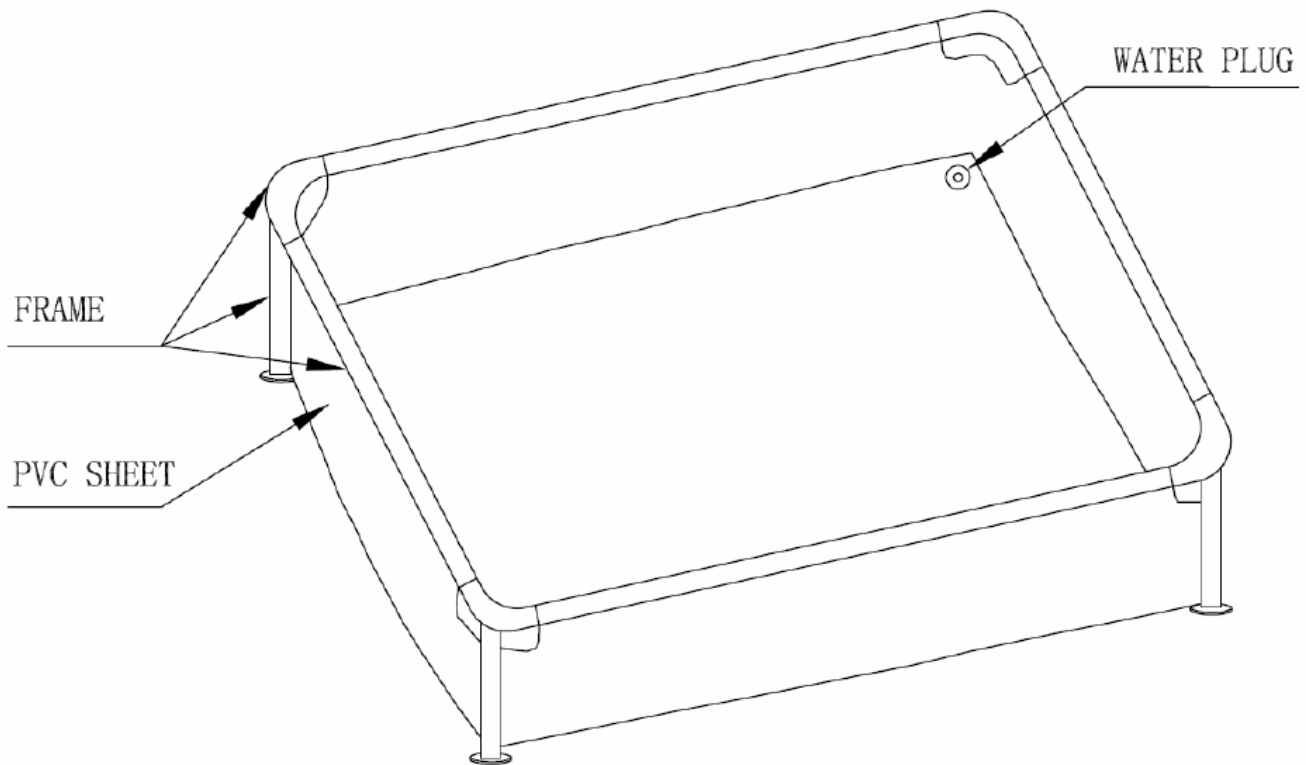

Addresses of the places of manufacture and storage:

Bestway (Europe) s.r.l. (Via Resistenza, 5, 20098 San Giuliano Milanese (Milano), Italy) license to Bestway inflatables and material corp. (No.3065 Cao An Road,Shanghai,201812,China) for production and storage of Bestway (Jiang Su) Plastics Corp. (No.8 Garden Road, Funing Economic Development Zone, Jiang Su, 224400, China)