

# Haier

Heat Pump Water Heater

## Installation and Service Manual

### Model

HP200M3

HP250M3

HP250M3C

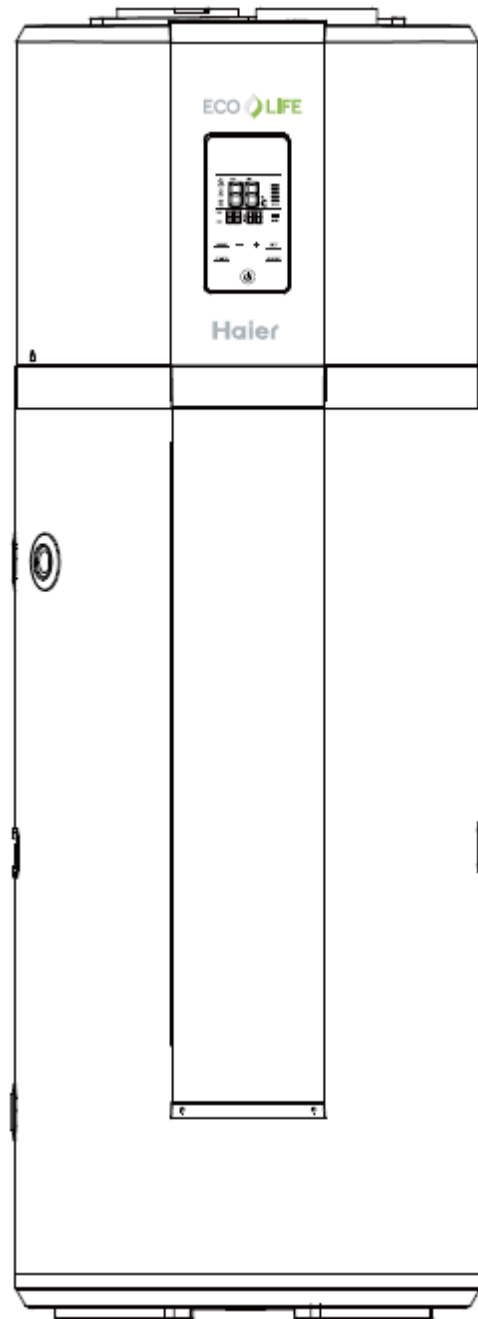

Please read this manual carefully prior to your use of this water heater.

The appearance of the water heater given in this manual is for reference only.

# Contents

1. Product safety statement.....	3
2. Functionings & principles .....	4
3. Technical parameters .....	5
4. Description of parts and components .....	6
5. Installation introduction .....	11
6. Operating and settings.....	22
7. Faults and protection .....	25
8. Faults and protection .....	26
9. The method of dismantling products .....	33
10. Repairs common tools .....	38

## 1. Product safety statement

1. This appliance can be used by children aged from 8 years and above and persons with reduced physical, sensory or mental capabilities or lack of experience and knowledge if they have been given supervision or instruction concerning use of the appliance in a safe way and understand the hazards involved. Children shall not play with the appliance. Cleaning and user maintenance shall not be made by children without supervision.

2. Children shall be closely supervised to make sure they stay away from this product.

3. The method of installing safety valve please refer to Page 16.

4. The water may drip from the discharge pipe of the pressure relief device and this pipe must be left open to the atmosphere.

5. The water heater is to be drained according to the instructions specified on page 27.

### Safety instructions (to be followed at any time)

Refrigerant: R134a; When handling product, you should

- No smoking
- Prevent the accumulation of electrostatic charges
- Work in a well ventilated place.
- Avoid contact with the skin and eyes
- Do not inhale the vapours
- Evacuate the hazardous area
- Stop the leakage

## 2. Functionings & principles

A low-pressure liquid refrigerant is vaporized in the heat pump's evaporator and passed into the compressor. As the pressure of the refrigerant increases, so does its temperature. The heated refrigerant runs through a condenser coil within the storage tank, transferring heat to the water stored there. As the refrigerant delivers its heat to the water, it cools and condenses, and then passes through an expansion valve where the pressure is reduced and the cycle starts over.

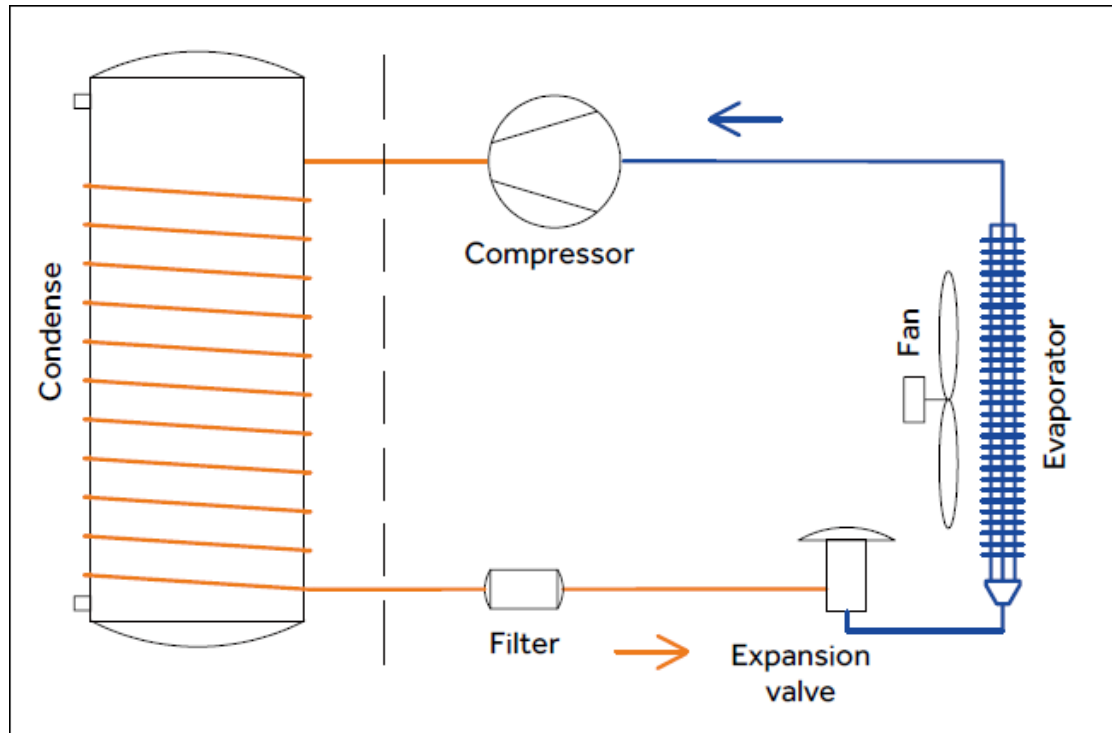

### 3. Technical parameters

Model	HP200M3	HP250M3	HP250M3C
Tank			
Tank volume	195L	246L	240L
Rated voltage/frequency	220V~240V/50Hz	220V~240V/50Hz	220V~240V/50Hz
Tank rated pressure	0.7MPa	0.7MPa	0.7MPa
Corrosion protection	Magnesium rod	Magnesium rod	Magnesium rod
Water proof grade	IPX4	IPX4	IPX4
Performances			
Type of extraction	Ambient / Exterior	Ambient / Exterior	Ambient / Exterior
COP@7°C/EN16147	3.04	3.02	3.10
COP@14°C/EN16147	3.39	3.41	3.56
Tapping cycle	L	L	L
Power input by electric backup	1500W	1500W	1500W
Rated power input by heat pump	495W	495W	495W
Maximum power input by heat pump	865W	865W	865W
Maximum power input	2365W	2365W	2365W
Standby power input/ Pes	27W	27W	27W
Max volume of usable hot water at 40°C setting at 55°C	224L	311L	332L
Heating uptime (7°C)	5.5 h	7.35h	6.92h
Heating uptime (14°C)	4.68h	6.17h	6h
Default temperature setting	55°C	55°C	55°C
Temperature setting range- with heater	35°C-75°C	35°C-75°C	35°C-75°C
Maximum length of air inlet duct	2.5m	2.5m	2.5m
Maximum length of air outlet duct	2.5m	2.5m	2.5m
Max working pressure of refrigerant	0.8/2.8MPa	0.8/2.8MPa	0.8/2.8MPa
Refrigerant type / weight	R134a/0.9kg	R134a/0.9kg	R134a/0.9kg
Sound power level	57dB	58dB	59dB
Ambient temperature for use of product	-7~35°C	-7~35°C	-7~35°C
Operating temperature of heat pump	-7~35°C	-7~35°C	-7~35°C
Dimension and connections			
Water inlet and outlet connection	G3/4"F	G3/4"F	G3/4"F
Safety valve connection	G3/4"F	G3/4"F	G3/4"F
Drain & Water inlet connection	G3/4"F	G3/4"F	G3/4"F
Product Dimensions	600*629*1692mm	600*629*1987 mm	600*629*1987 mm
Packing dimension without pallet	736*695*1810 mm	736*695*2120 mm	736*695*2120 mm
Packing dimension with pallet	736*695*1940 mm	736*695*2250 mm	736*695*2250 mm
Net/Gross weight	91/103kg	102/115kg	119/132kg
* The COP and noise level data was tested in Haier lab			

## 4. Description of parts and components

Heat pump structure (HP200M3/HP250M3)

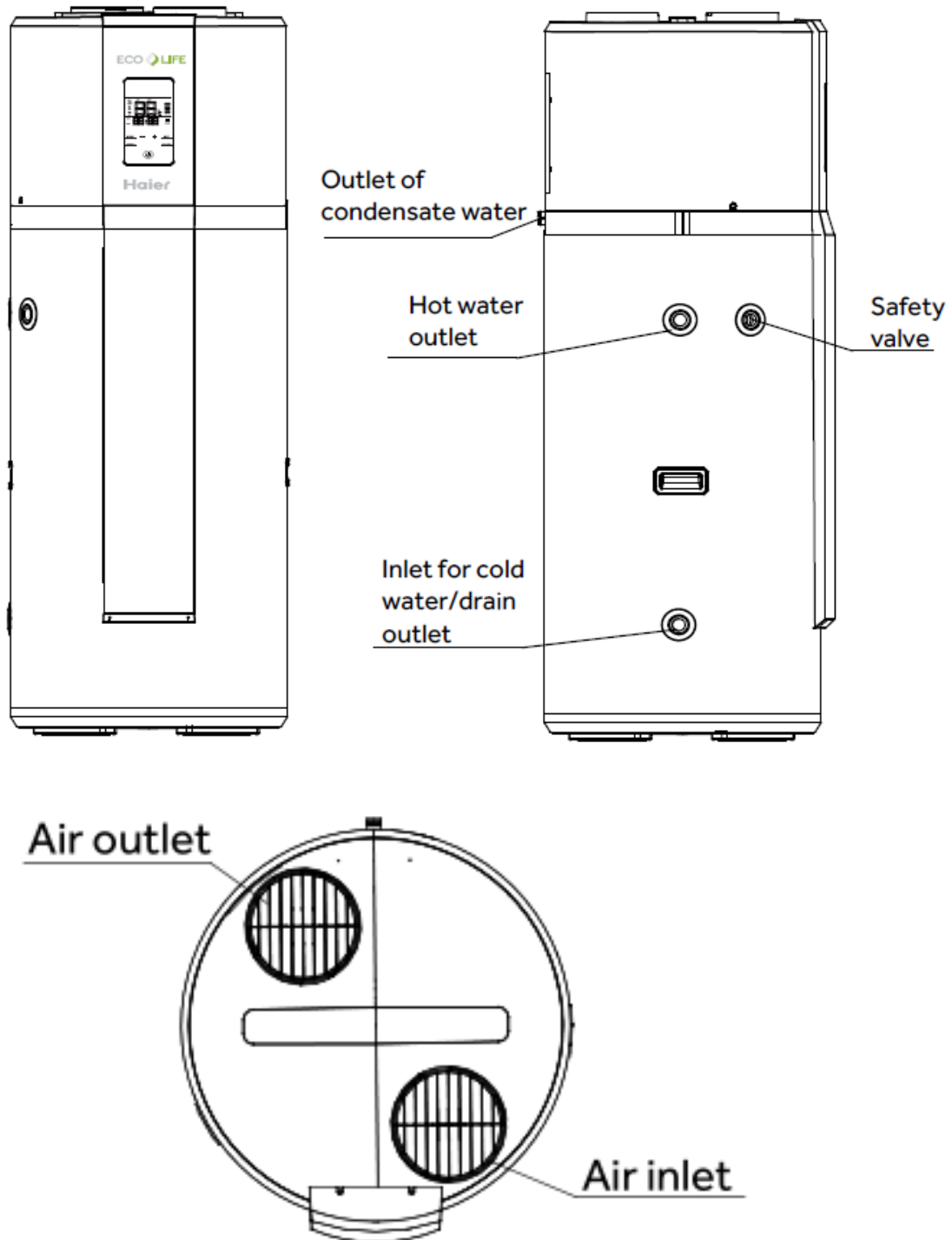

Heat pump structure (HP250M3C)

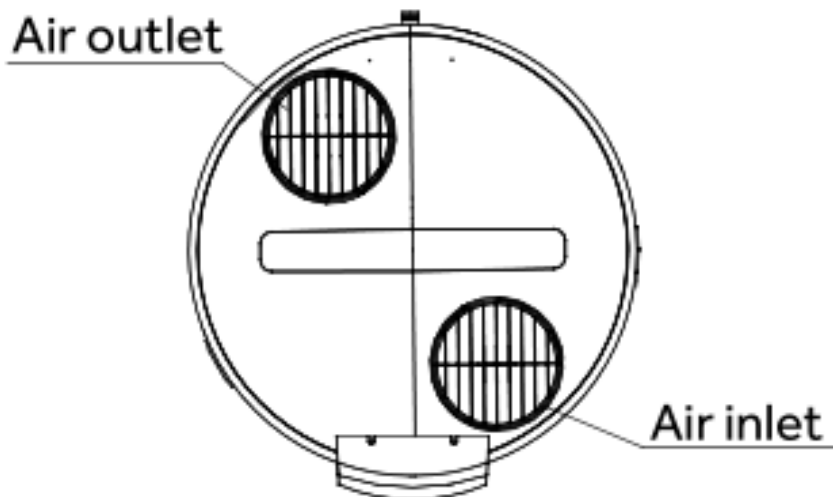
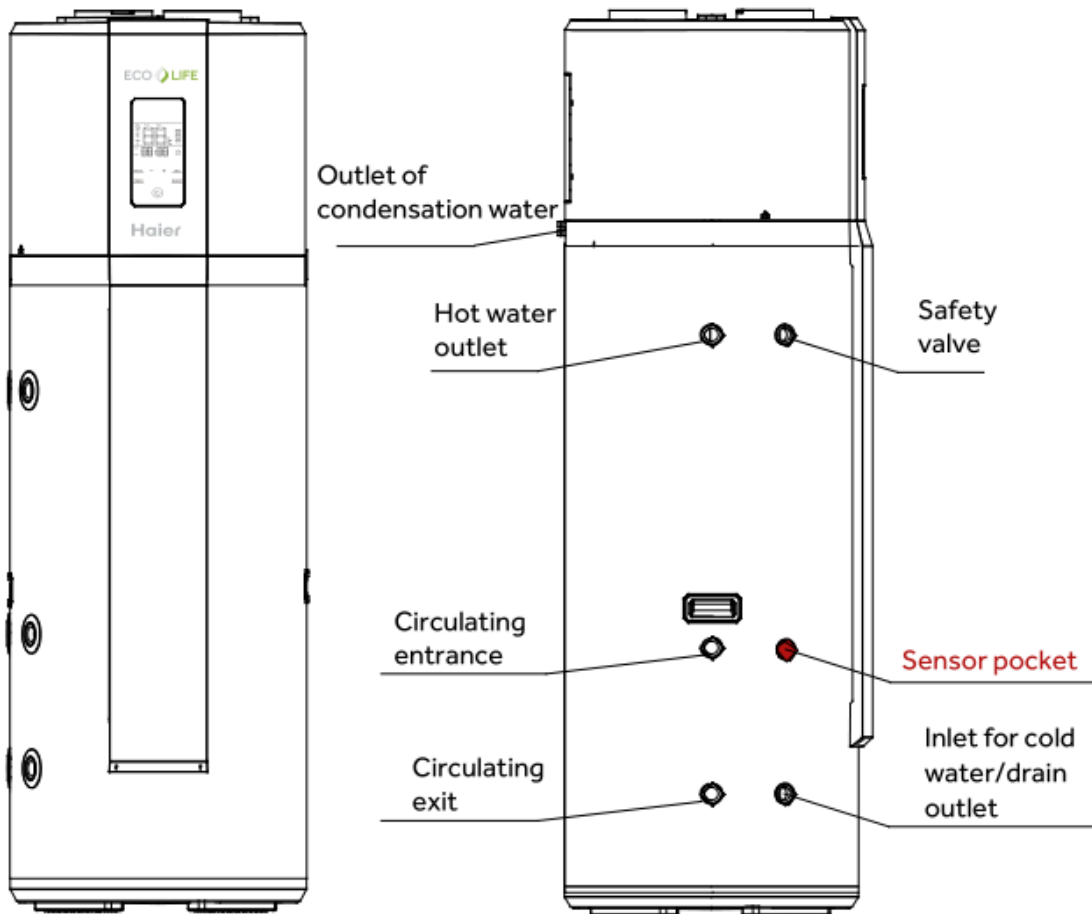

# Exploded view

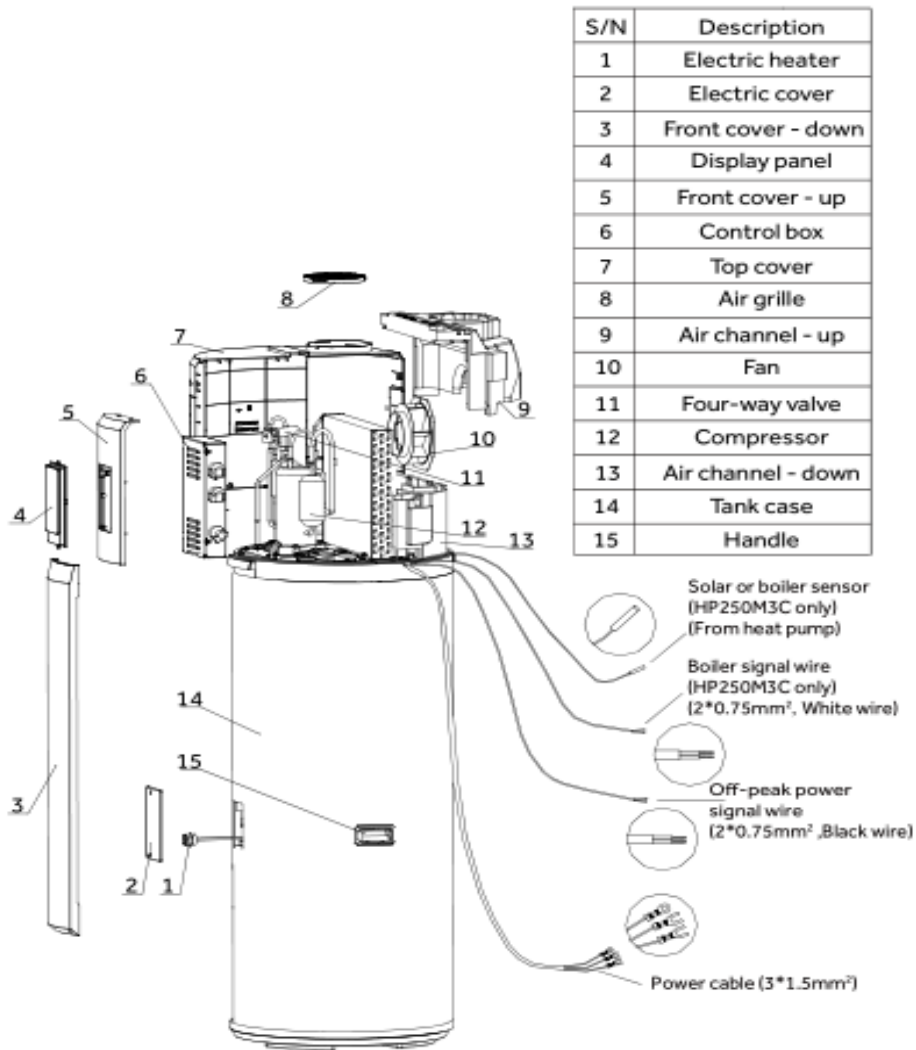

## Heat pump system components

### 1. Compressor

The compressor is to effect a low-temperature low-pressure evaporator refrigerant vapor sucked and compressed into high temperature and pressure of the superheated vapor, and then discharged to the condenser heat exchanger.

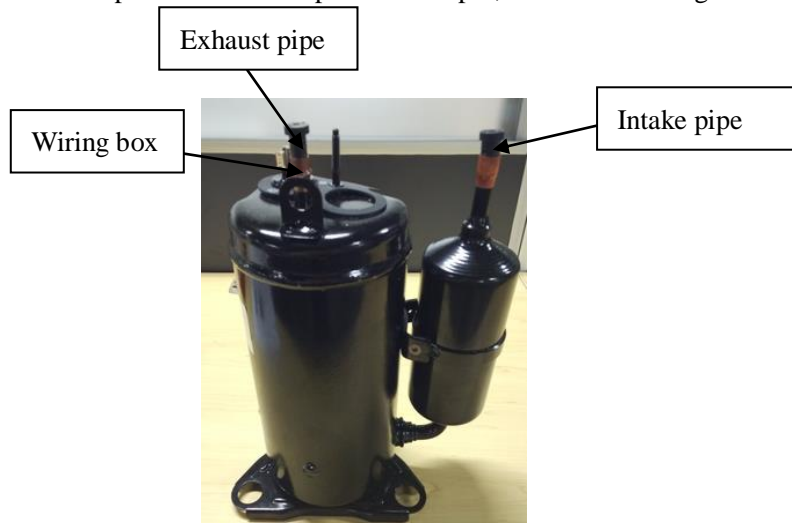



## 2. Evaporator

Evaporator effects: it makes the liquid refrigerant absorb heat and is evaporated into steam.



## 3. Condenser

A condenser: high-temperature high-pressure refrigerant vapor is condensed into liquid, during condensation, the refrigerant vapor discharge heat, the heat is absorbed by the heating medium.



## 4. Electronic expansion valve:

The refrigerant passes through the electric expansion valve, the pressure from the condensing pressure is reduced to the evaporation pressure, part of the refrigerant will evaporate into gas in the throttling process.

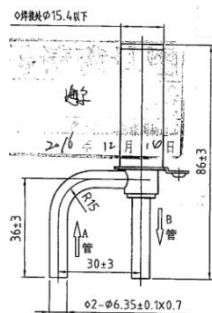

## 5. Filter

It's interior has a filter and desiccant, the desiccant absorbs moisture from the refrigerant, the filter can filter out impurities in the refrigerant.



#### 6. High Voltage Switchgear

High-voltage switch is to prevent excessive pressure in the system, thus affecting the life of the system components, high-pressure of the high-voltage switch is 2.8MPa.



#### 7. Service valve

Service valve is mainly used for filling refrigerant, after removing the nuts, it contains a valve needle, sales staff can vacuum infusion refrigerant from here.

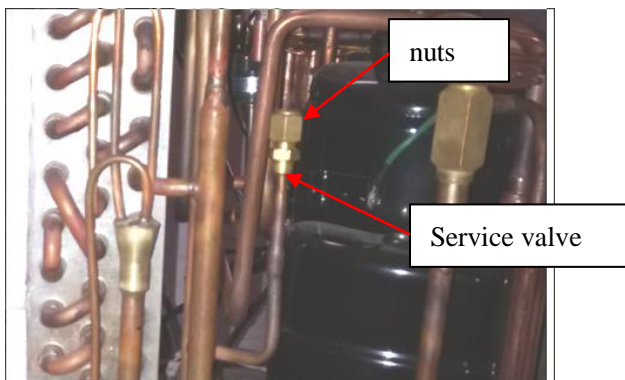

#### 8. Fan

It forced air through the duct, and then flows through a heat exchanger to improve heat transfer efficiency of the heat exchanger.



## 9. Refrigerant

Heat pump refrigerant is R134a, ODP value is 0, no damage to the ozone layer. R134a refrigerant cans appearance is as follows:



## 5. Installation introduction

### a. Installation precaution

- Do not install the water heater in the position where exposed to gas, vapours or dust.
- Install the appliance on a flat, solid surface. The surface can support the machine weight and the condensate water can be drained freely.
- Noise due to operating and air flow do not bother neighbors.
- Make sure there is sufficient space left for installation and maintenance.
- There is no strong electromagnetic interference around that may affect control functions.
- There is no sulfur gas or mineral oil existing at the installation place, which may cause corrosion of the machine and the fittings.
- The water pipe for the water heater used at temperatures below 0 °C shall not freeze.
- It shall not be set in rooms where a heating system is used so that heating supply to the room will not be affected.
- It shall not be set inside a totally-enclosed space.
- The air taken in must in no event be dusty.
- Install the appliance in a dry, frost-free room.
- Temperature of the ambient air or of the air taken in by the heat pump for optimum running:

from 10 to 35 °C.

Keep an adequate distance between the working heat-pump and the resting places.

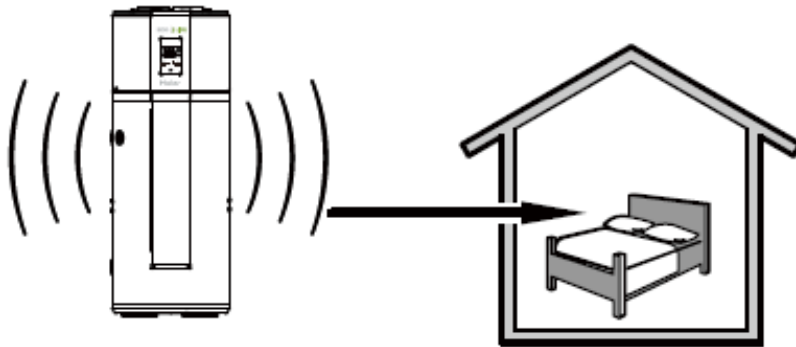

b. Installation dimensions (mm)

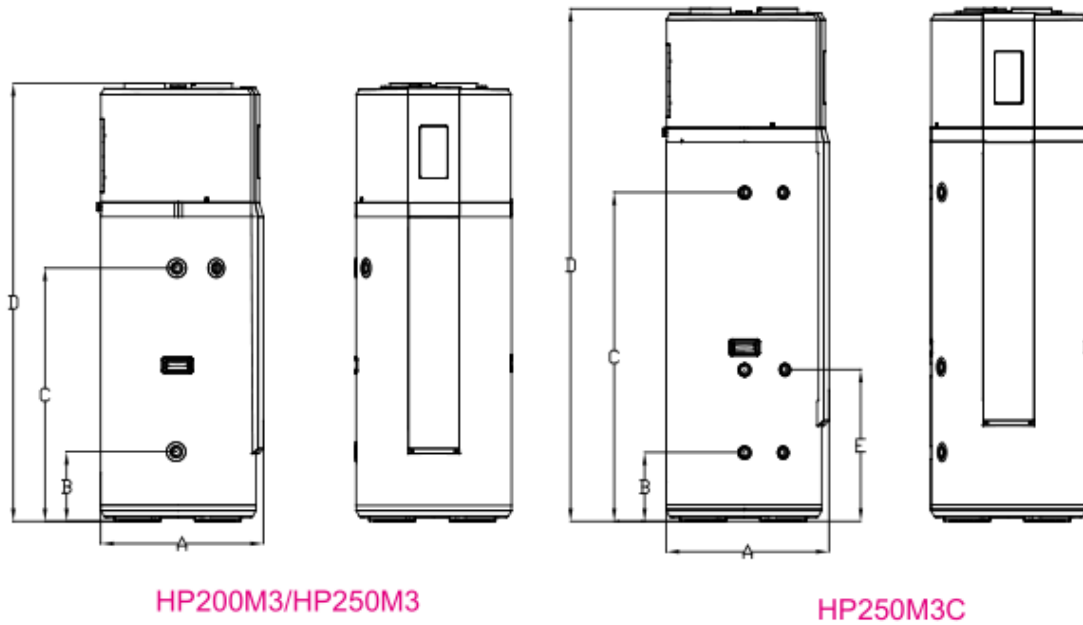

HP200M3/HP250M3

HP250M3C

Unit:mm

Model	A	B	C	D	E
HP200M3	629	270	980	1692	
HP250M3	629	270	1275	1987	
HP250M3C	629	270	1275	1987	590

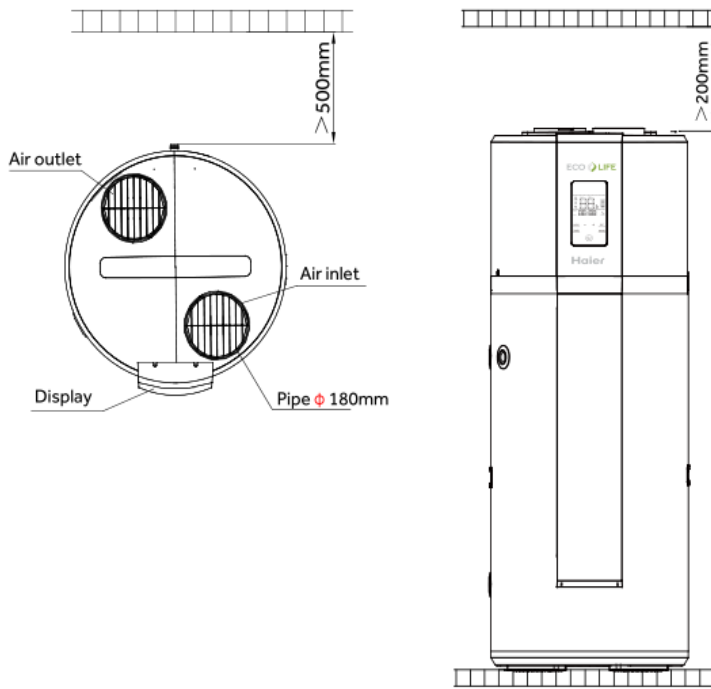

c. Installation angle refer to the following diagrams

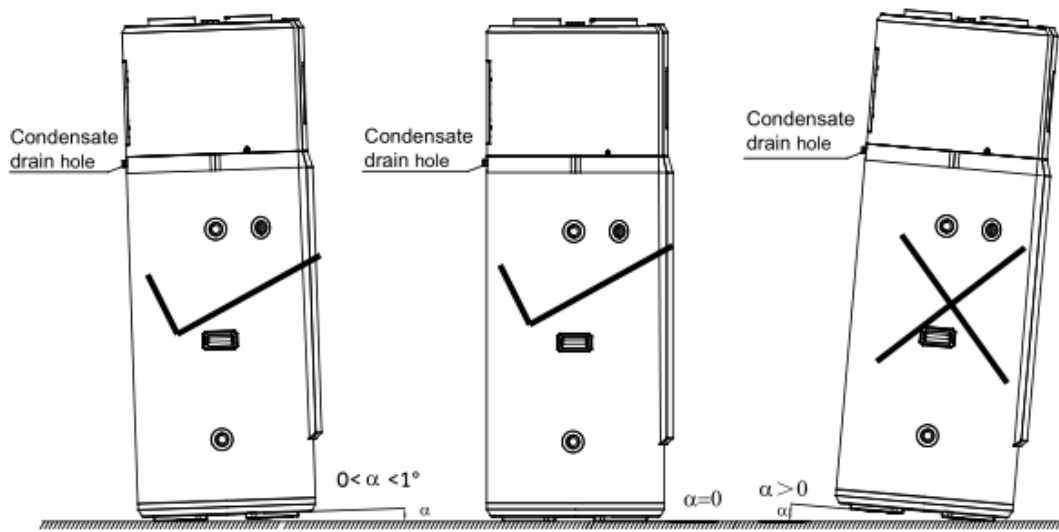

Pipe connection

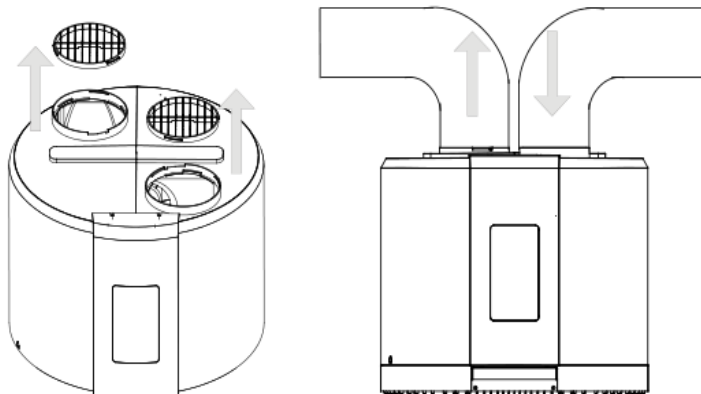

- Remove vent grid first.

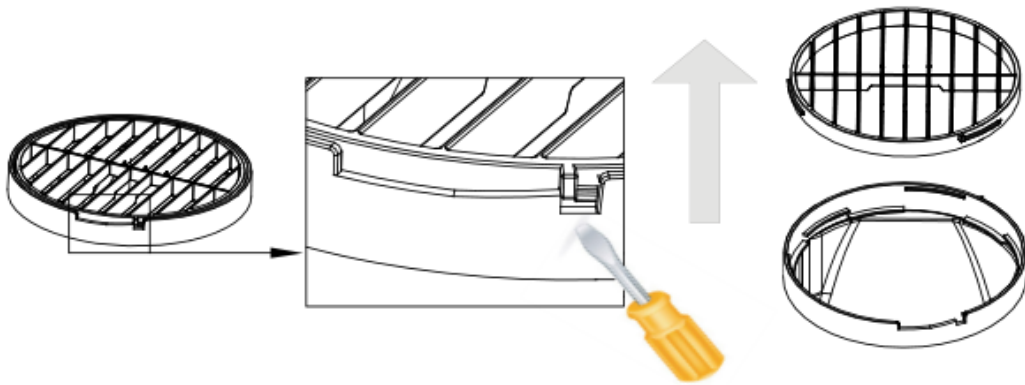

- Install diameter 180mm duct.
- Pressure drops from duct must be lower than or equal to the static pressure of the fan.
- If the pressure drops out of range, the performance of the appliance will be impaired.

Maximum length of the air connection 5m (Diameter of air connection 160 mm).

### c. Advised positions

Garage or laundry room (without ducts):

- Unheated room.
- Enables recovery of the free energy released by your vehicle's engine when switched off after use or by household appliances in operation.

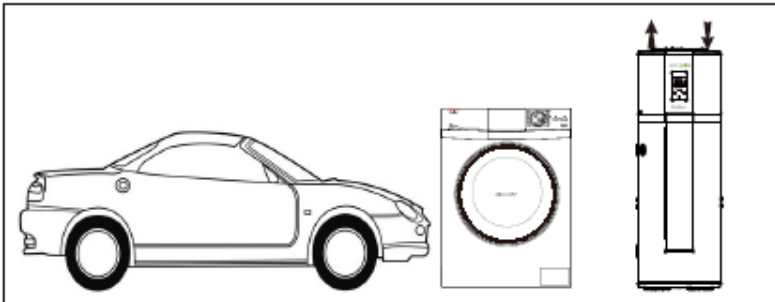

Laundry room (with one duct):

- Unheated room.
- Enables recovery of the free energy released by your vehicle's engine when switched off after use or by household appliances in operation.
- Referring installer menu, adjust the fan speed.

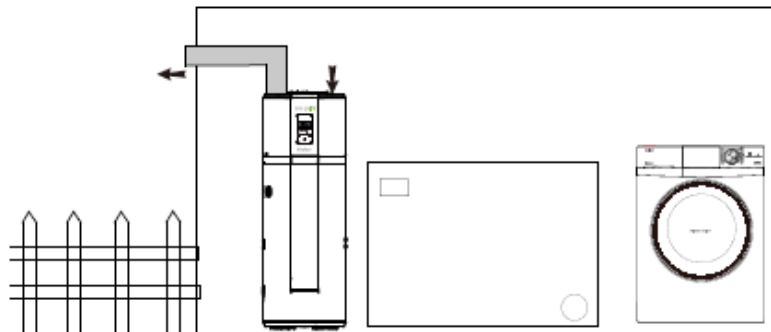

Habitable room or outside air (with two ducts):

-Can obtain free heat from the garage.

-If the outside air temperature is low, connection to the outside air may lead to overconsumption of electricity.

-Referring installer menu, adjust the fan speed

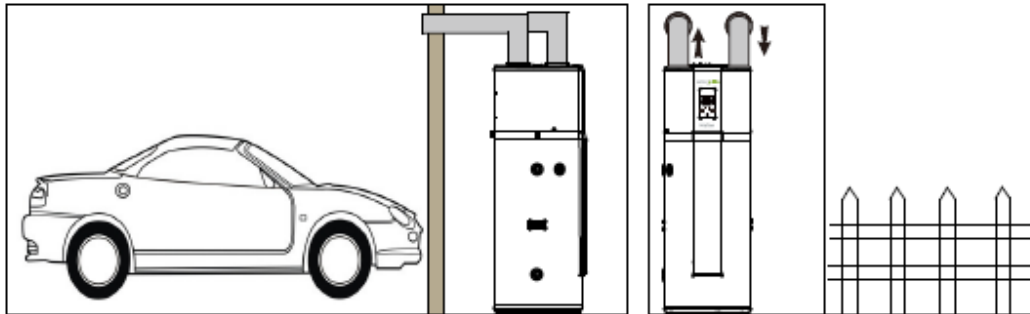

#### d. Installation caution

When making the connections, you should respect the standards and local directives.

- Before making the connection, rinse the drinking water inlet pipes and water tank exchanger (HP250CM2), in order not to introduce metal or other particles into the tank.

Select copper pipes for pipeline connection.

- The inlet water pressure is between 0.1~0.5MPa. If lower than 0.1 MPa, a booster pump shall be added at the water inlet; if higher than 0.5 MPa, a pressure relief valve shall be added at the water inlet.

- The inlet water temperature is suggested between 10-30° C.

- Outdoor water pipeline and valves should be proper insulated.

- In accordance with safety rules, a safety valve(7bar,99° C,G3/4M) must be installed on the tank. For France, we recommend hydraulic safety units fitted with a membrane with the NF marking.

Integrate the safety valve in the cold water circuit. Install the safety valve close to the tank in a place which is easy to access.

No isolating devices should be located between the safety valve or unit and the tank

The rated pressure of the safety valve shall not exceed 0.7MPa.

- The outlet pipe in the valve or safety assembly must not be blocked.

- The diameter of the safety unit and its connection to the calorifer must be at least equal to the diameter of the domestic cold water inlet on the calorifer.

- If the mains pressure exceeds 80% of safety valve, a pressure reducer must be installed upstream

of the appliance.

Do not connect the domestic hot water connection directly to copper pipes in order to prevent galvanic couples in iron/copper (risk of corrosion). It is compulsory to fit the domestic hot water connection with a dielectric connection (not supplied).

### Installation A

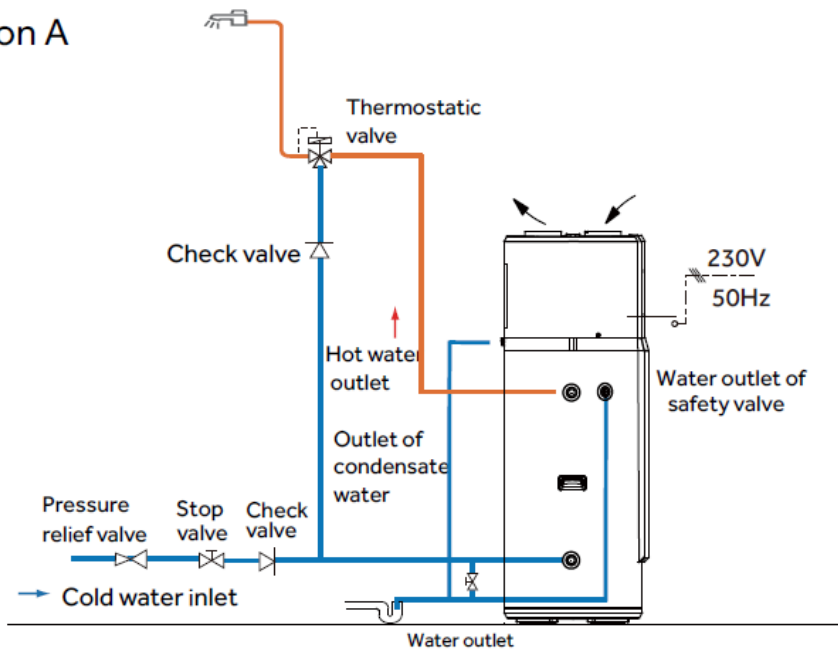

### Installation B

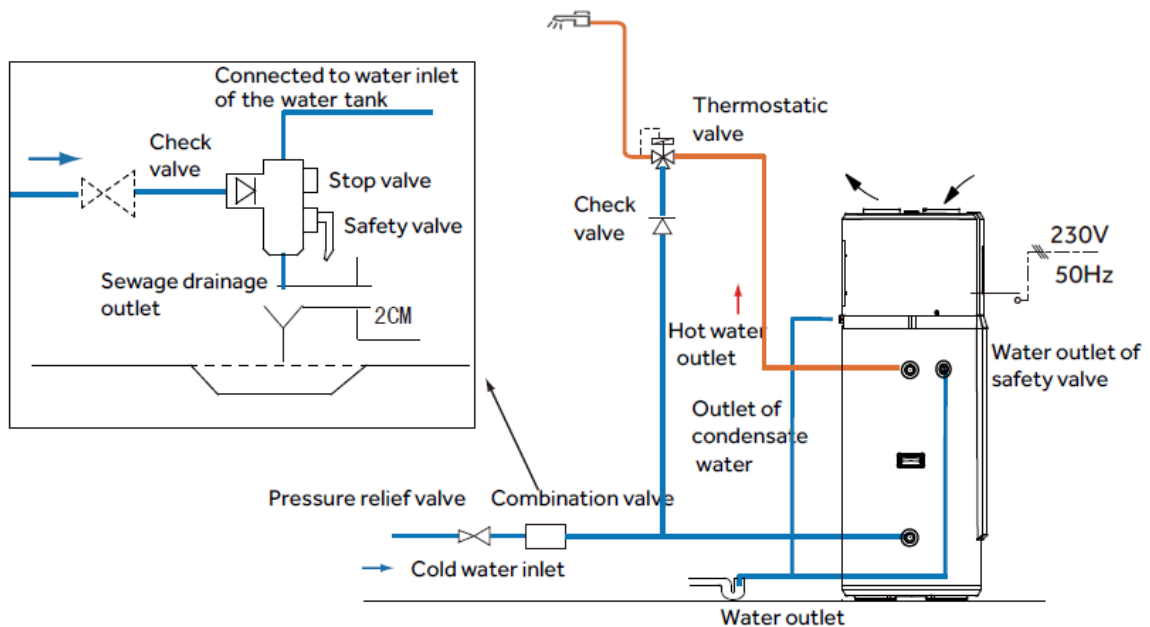

- Pressure relief valve, thermostatic valve, stop valve, check valve, T&P valve and French combination valve are not included in the accessories, please select proper fittings in local market;
- Valves with NF/CE certification are recommended



e. Connection to solar collectors (Version HP250M3C)

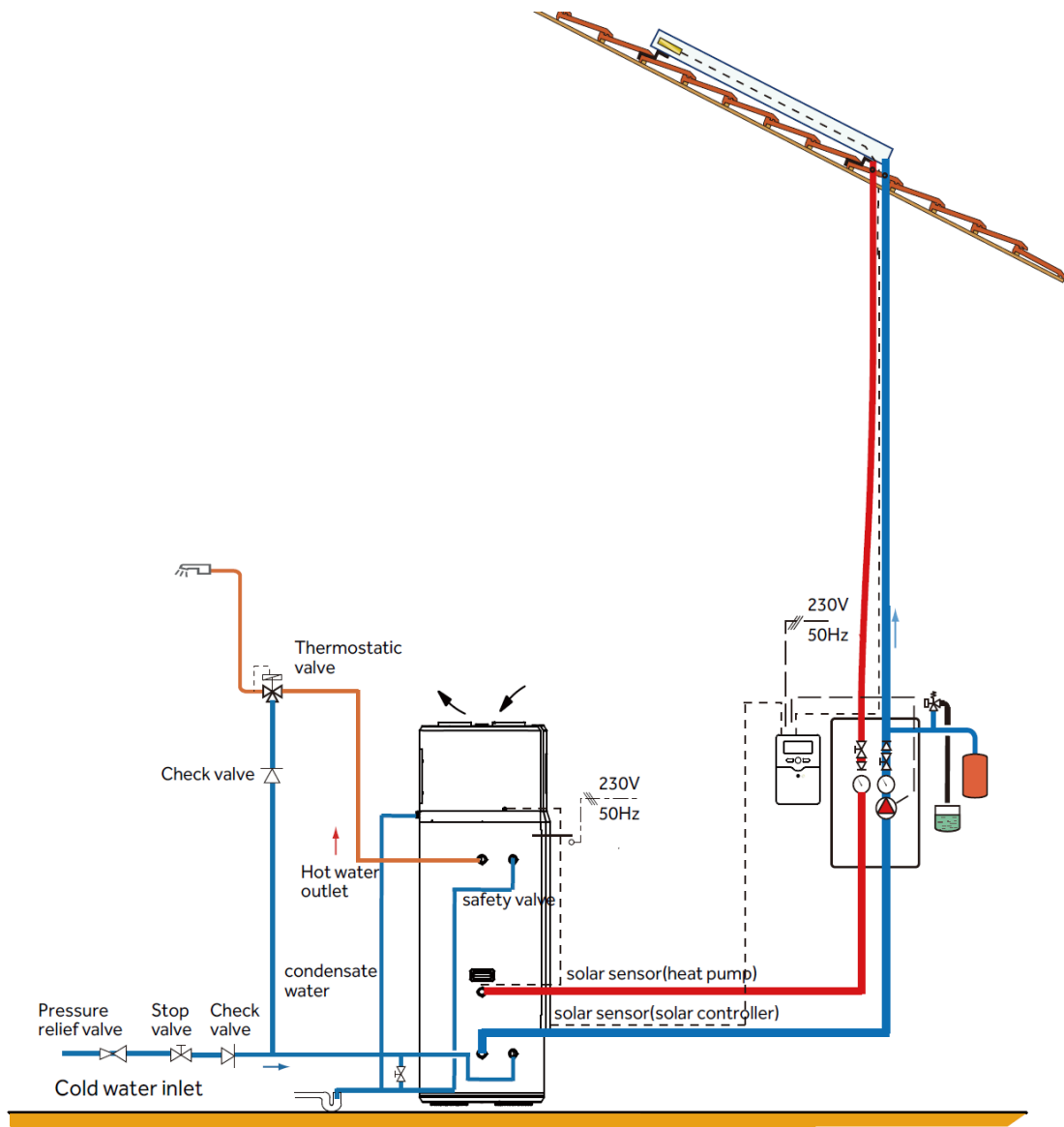

**WARNING: Plumber -Be Aware**

Using solar energy, please make sure that the heat pump water tank temperature not more than 85 °C.

f. Connection to gas boiler (Version HP250M3C)

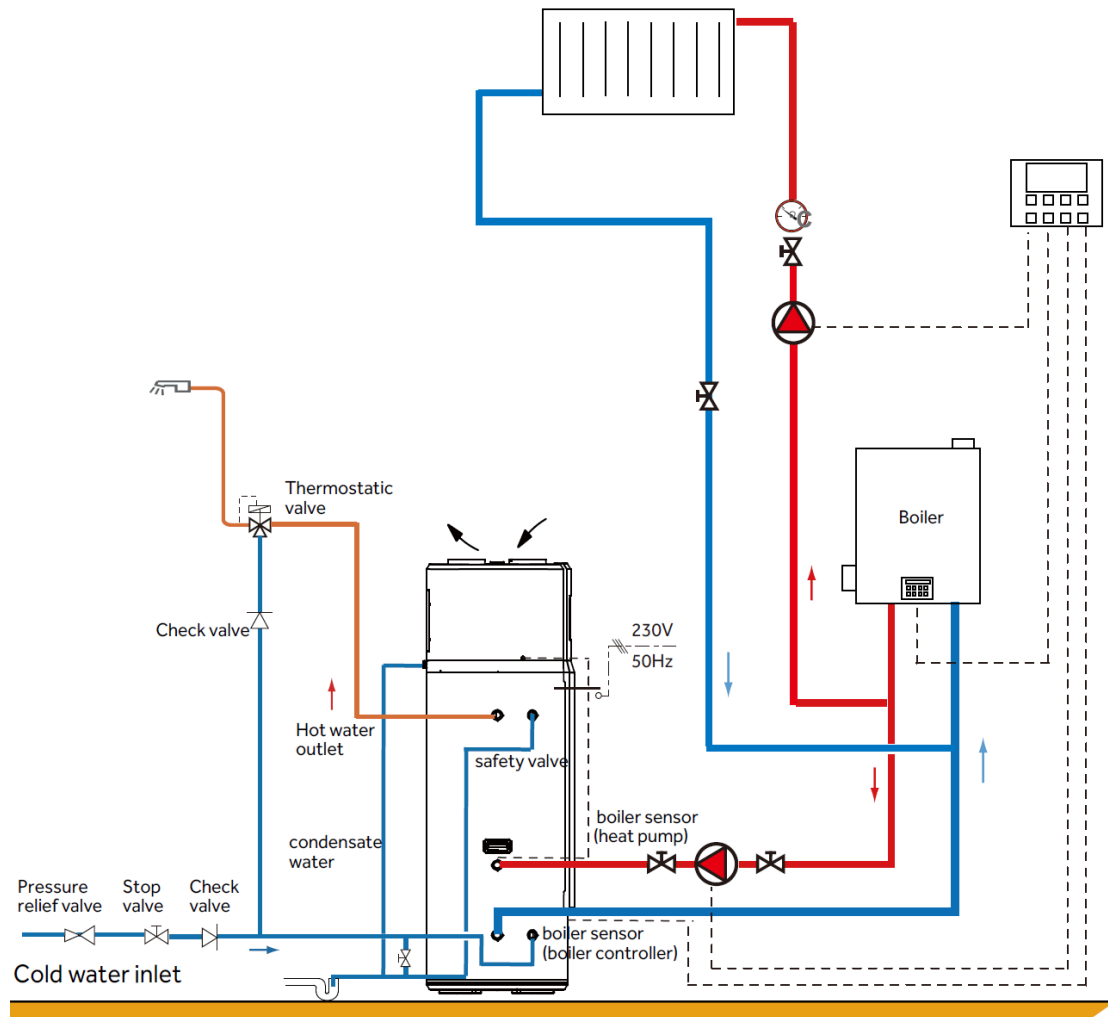

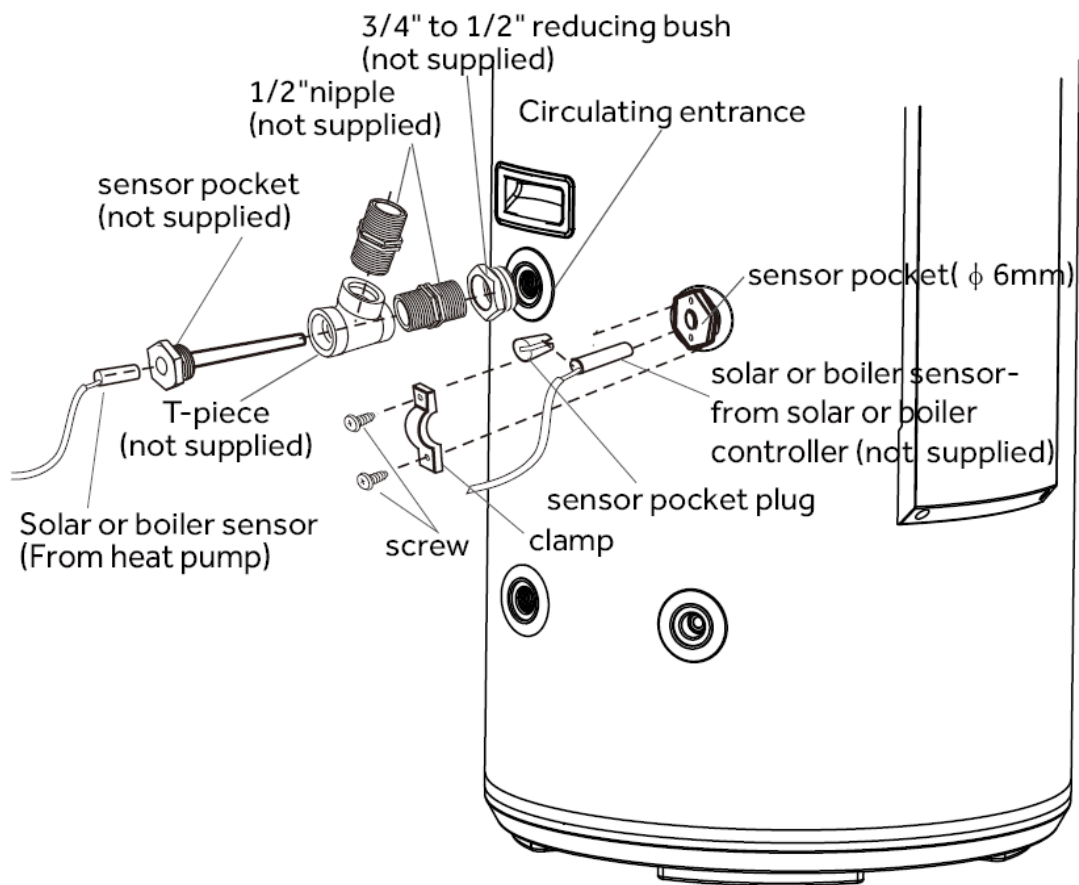

**WARNING: Plumber -Be Aware**

Using boiler auxiliary heating, please make sure that the heat pump water tank temperature not more than 85 °C.

**g. Electrical connections precautions**

**WARNING**

- Only qualified professionals may carry out electrical connections, always with the power off.
- The earthing shall comply with local standards.
  
- Water heaters shall be equipped with a dedicated power line and residual current circuit breakers. The action current shall not exceed 30 mA;
  
- The ground line and the zero line of the power supply shall be separated entirely. Connecting the zero line to the ground line is not allowed.
  
- Parameter of the power line: 3×1.5mm<sup>2</sup> or more.
  
- If a power cable is damaged, it shall be replaced by qualified professionals to avoid risks.
  
- In the case of places and walls where water may be splashed to, installation height of a power

socket shall not be less than 1.8 m, and it shall be ensured that water would not be splashed on these places. The socket shall be installed out of children's reach.

- The phase line, zero line and ground line inside a power socket used in your home shall be wired correctly without any wrong positioning or false connection, and internal short circuit shall be avoided. Wrong wiring may cause fire accidents.

### h. Connection with timer programming

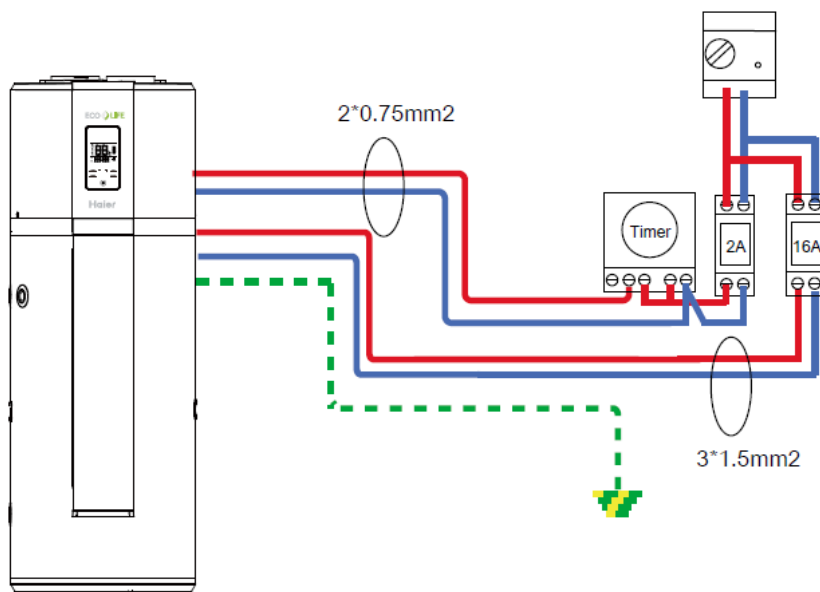

### Connection with the meter with direct contact

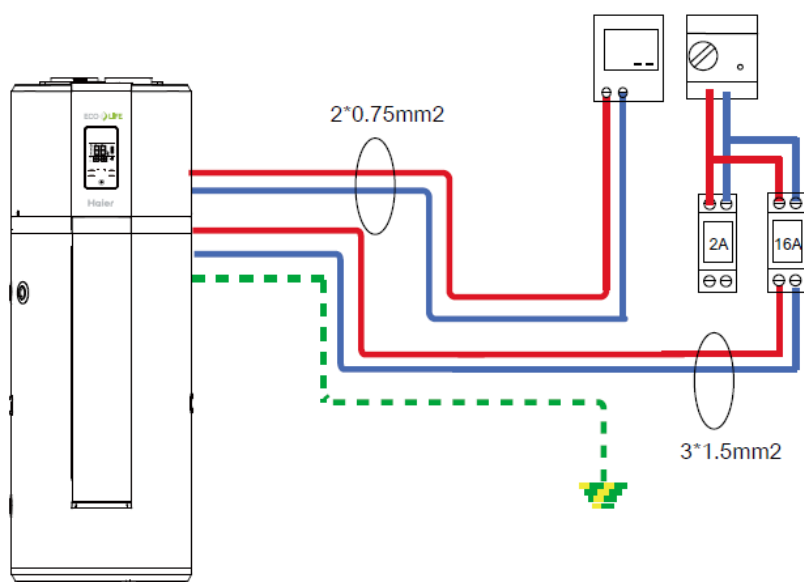

### Connection with boiler back up(only for HP250CM2)

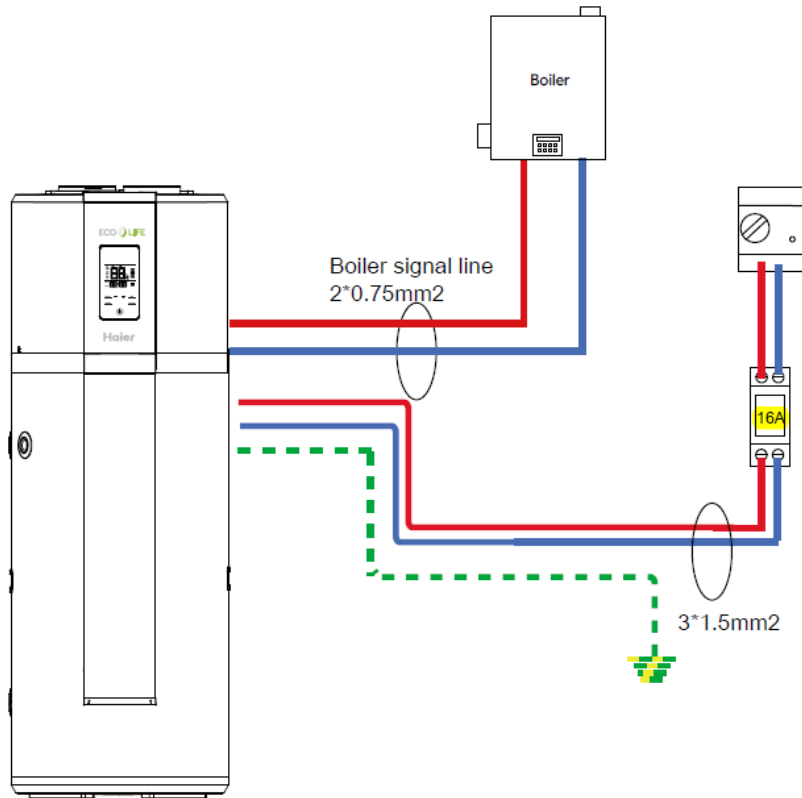

Boiler signal line 2\*0.75mm2

- Connect the boiler back-up connector (boiler back-up).refer to the boiler instruction manual.
- Referring installer menu, adjust the parameters **AH** and **65** .

### i. Wiring diagram

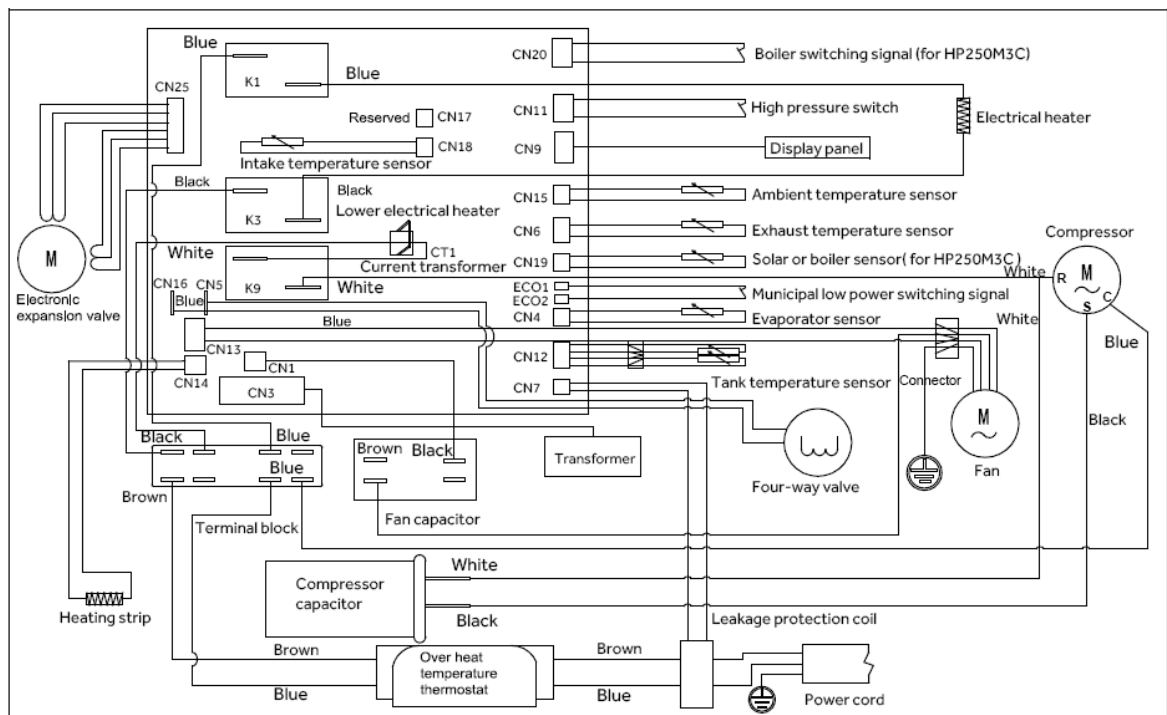

## 6. Operation and functions

### Display



### Functions:

#### Electrical leakage protection

The control system of this machine features an electricity leakage protection function.

#### 10-minutes protection

When starting the machine immediately after electricity input, the fan and the compressor will start at the same time. When starting the machine immediately after shutdown, the system goes into the protection mode and starts after 10 minutes, which is considered to be normal.

#### Automatic defrosting function

The defrosting mode is automatically activated if the ambient temperature is too low and after the compressor already runs continuously for a certain period.

#### Overload protection











The working load of the compressor will be heavy if temperature is high in summer. In order to meet hot water requirements of users and to lengthen service life of the compressor, this product automatically adjusts the fan speed to ensure reliable operation of the compressor.

#### Anti-freezing function







The heat-pump starts heating to avoid freezing of the water tank if the temperature in the water tank is too low.

The default temperature setting is 55 °C.

## Description of the pictograms

Symbol	Description
	Power ON/OFF switch
	Work made selection
	Confirm button
	Timer adjust
	Boost mode. Heat pump and electric heater are activated at the same time.
	<u>Auto mode</u> <ul style="list-style-type: none"> <li>- Prior using heat pump;</li> <li>- If heat pump works more than the default 8 hours , start the electric heater</li> <li>- The default working time can be adjust in the installer settings.</li> </ul>
	<u>ECO (off-peak) mode</u> <ul style="list-style-type: none"> <li>- In this mode ,priority using heat pump.</li> <li>- In two ways using heat pump,should set in the installer settings               <ol style="list-style-type: none"> <li>1- manually set off-peak time;</li> <li>2-switch signals by power companies.</li> </ol> </li> </ul>
	<u>Holiday mode</u> <ul style="list-style-type: none"> <li>- According to the vacation dates in advance to prepare hot water;</li> <li>- For example, you leave home for vacation on January 1st and return home on January 5th. The date shall be set as (5-1) =4 days, and corresponding temperature shall also be set. The heat-pump will start heating on 00:00 o'clock of January 5th automatically.</li> </ul>
	<ul style="list-style-type: none"> <li>- Anti-legionella</li> <li>- Anti-legionella function will be activated every 7 days to heat the tank to 65°C automatically .</li> </ul>
	Hot water volume display

## Installer settings

- To open the installer settings, press  switch off the system, then press  and  at the same time for 10 seconds.
- When menu is open, press  or  to change the value of the settings.
- Press  to confirm the settings.
- Press  to close the menu.

Parameters	Description	Factory setting	Adjustment range
LL NO, NC	<u>Off-peak signal type</u> When you use off-peak time clock control, first determine the type of signals, Only allow professional installers to operate. - NO corresponds to Normally Open Signal. - NC corresponds to Normally Close Signal.	NO	NO , NC
LP 01, 02	<u>Off-peak logic type</u> - In two ways using heat pump, should set in the installer settings -01 manually set off-peak time; -02 switch signals by power companies.	01	01 , 02
AL ON, OF	<u>Avoid Legionella</u> - This parameter is used to activate the legionella protection mode. - Once every 7 days, all domestic hot water is heated to 65°C.	ON	ON , OF
AH 1, 2, 3	<u>Auxiliary Heating</u> - 1 corresponds to electrical back-up. - 2 corresponds to electrical and boiler back-up. - 3 corresponds to electrical and solar back-up.	1	1,2,3
OS NO, NC	<u>Boiler output signal type</u> - NO corresponds to boiler Normally Open Signal. - NC corresponds to boiler Normally Close Signal.	NO	NO , NC
FS 1, 2, 3	<u>Fan speed</u> - 1 corresponds to water heaters without ducts. - 2 corresponds to semi-ducting, with a single duct installed. - 3 corresponds to ducts on both the inlet and the outlet.	1	1,2,3
AA 5-10	<u>Heat pump working time</u> - If heat pump work more than Set Time, start electric heating.	8h	5-10h



## 7. Checking and maintenance

- Installation and maintenance of the appliance must be done by a qualified professional .
- Before working on the appliance, Shut down the machine and cut off the power supply .
- Do not touch with wet hands.
- Maintenance operations are important to guarantee optimum performance and extend the life of the equipment.

### Checking the Safety valve

- Operate the safety valve at least one time per month to check if it is running correctly. Otherwise check for blocking and replace the safety valve if necessary.

### Checking the hydraulic circuit

- Check the watertightness of the water connections.

### Cleaning the fan

- Check the cleanliness of the fan one time per year.

### Checking the evaporator

- Clean the evaporator at regular intervals using a soft-haired brush.
- If they are bent. Carefully realign the evaporator using a suitable comb.
- Because the evaporator fins is very sharp. Risk of injury on your finger.
- Do not damage the fins. Avoid affecting the performance.

### Checking the condensates discharge pipe

- Check the pipe cleanliness
- An obstruction by dust may cause poor condensates flow or even a risk accumulation of water in the heat pump plastic base.

### Checking the Magnesium rod

- The magnesium anode should be replaced in time, avoid tank corrosion.
- Checking magnesium anode once every 2 years .In poor water areas need to shorten the time.

### Drain the water tank to empty

Cut off power supply and shut down water inlet valve, then drain the water tank to empty via the sewage outlet. Please stay away from the sewage outlet if there is hot water inside the water tank to avoid injury.

## 8. Faults and protection

Fault type	Action	Digital indication	Release
Compressor protection	Operating temperature protection	F2	After fault is solved, switch on power supply for release
	Air exhaust temperature protection	F3	
	Evaporation high temperature protection	F5	
Compressor over-current protection	Over-current protection	F6	
Electricity leakage alarming	The system will automatically cut off power supply if any line fault occurs	E1	After fault is solved, switch on power supply for release
Over temperature alarming	The actual water temperature $\geq 85^{\circ}\text{C}$	E2	
Fault of the inner temperature sensor	If short circuit or circuit break occurs to the sensor	E3	
Fault of the ambient temperature sensor	If short circuit or circuit break occurs to the sensor	E4	
Fault of the evaporation temperature sensor	If short circuit or circuit break occurs to the sensor	E5	
Fault of the air exhaust temperature sensor	If short circuit or circuit break occurs to the sensor	E6	
Fault of the air intake temperature sensor	If short circuit or circuit break occurs to the sensor	ED	
Communication fault	Communication of main control panel and display panel is abnormal	E7	
Pressure switch protection	Action of the pressure switch at the exhaust outlet	E8	
Ambient temperature protection	Ambient or outdoor temperature $< -7^{\circ}\text{C}$ or $> 37^{\circ}\text{C}$	E9	
Fault of the Solar or boiler temperature sensor	If short circuit or circuit break occurs to the sensor (for HP250M3C)	EE	
Fault of the Off-peak power switching signal	If not received the Off-peak signal when selecting switch signals by power companies	EF	

## Fault code identification method:

### " E1 "error code and identification process

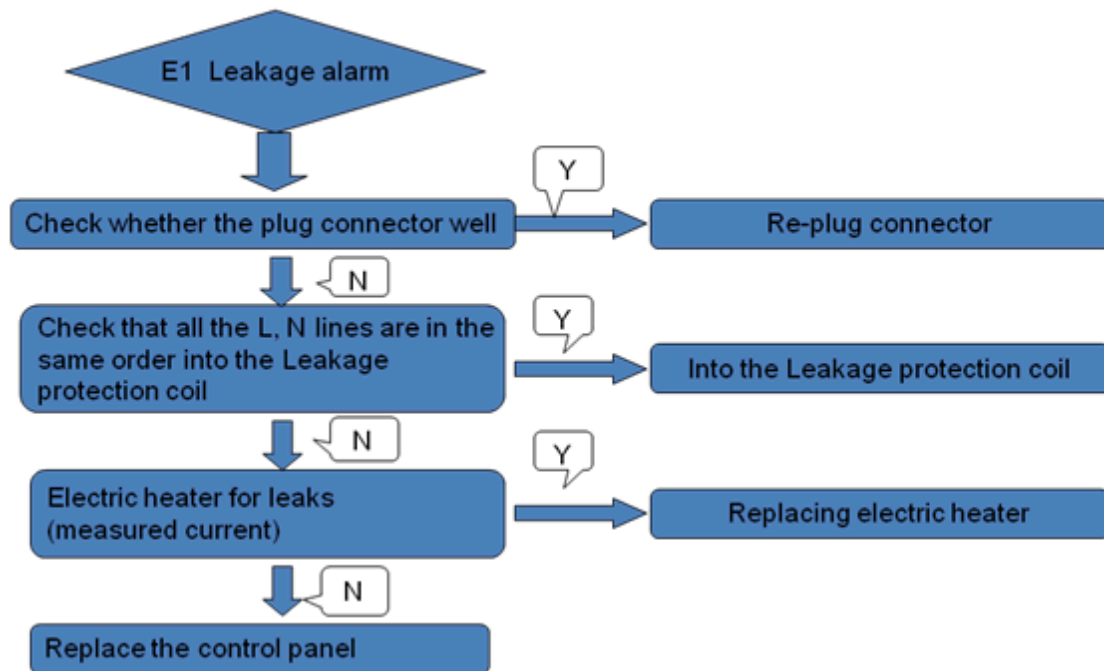

### "E2" error code and identification process

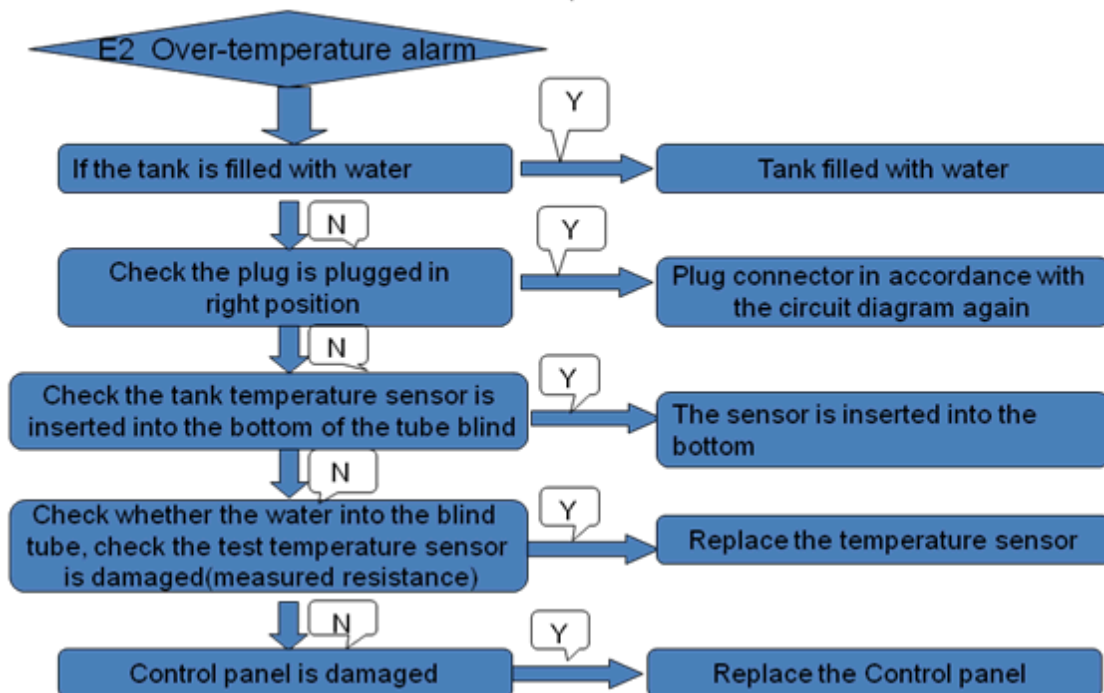

### “E3、 E4 、 E5 、 E6、 Ed” error code and identification process

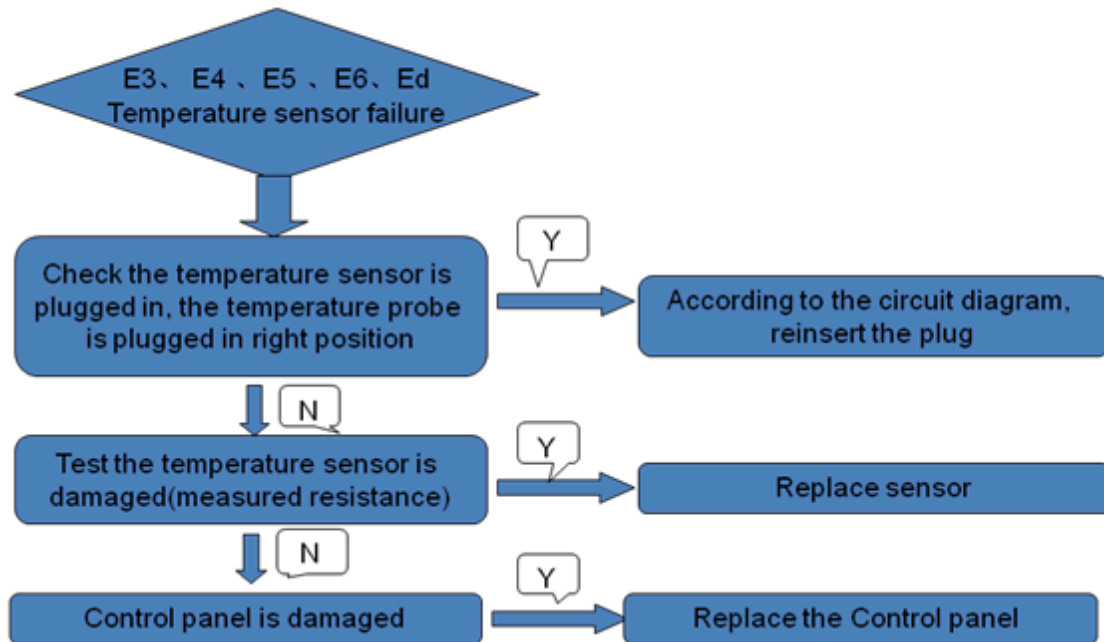

### “E7” error code and identification process

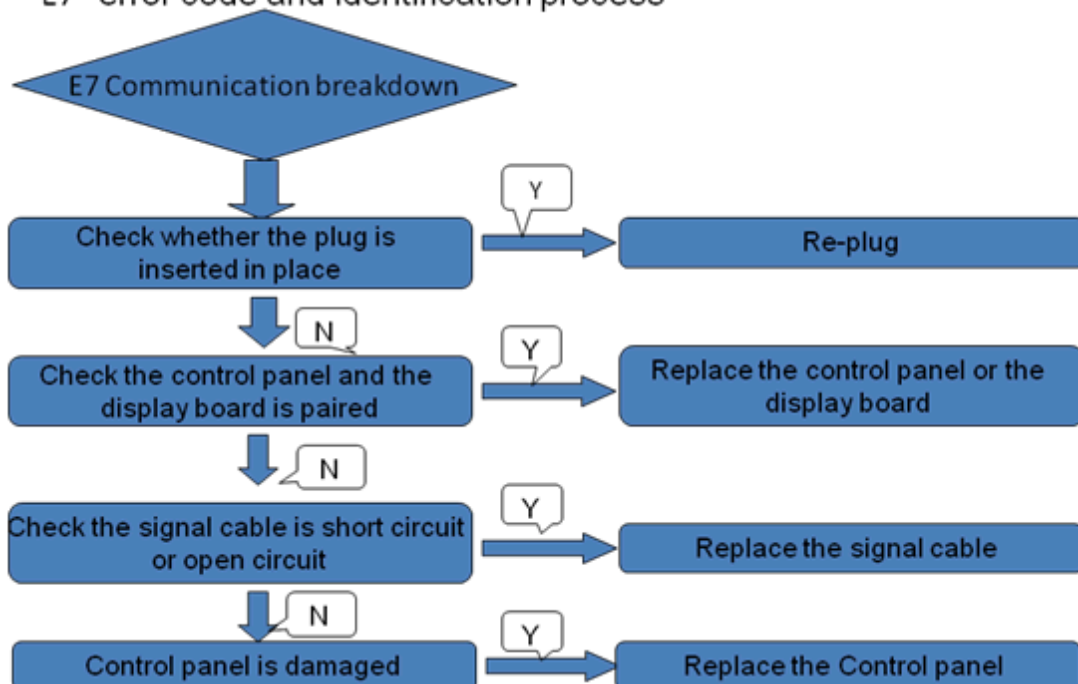

“E8” error code and identification process

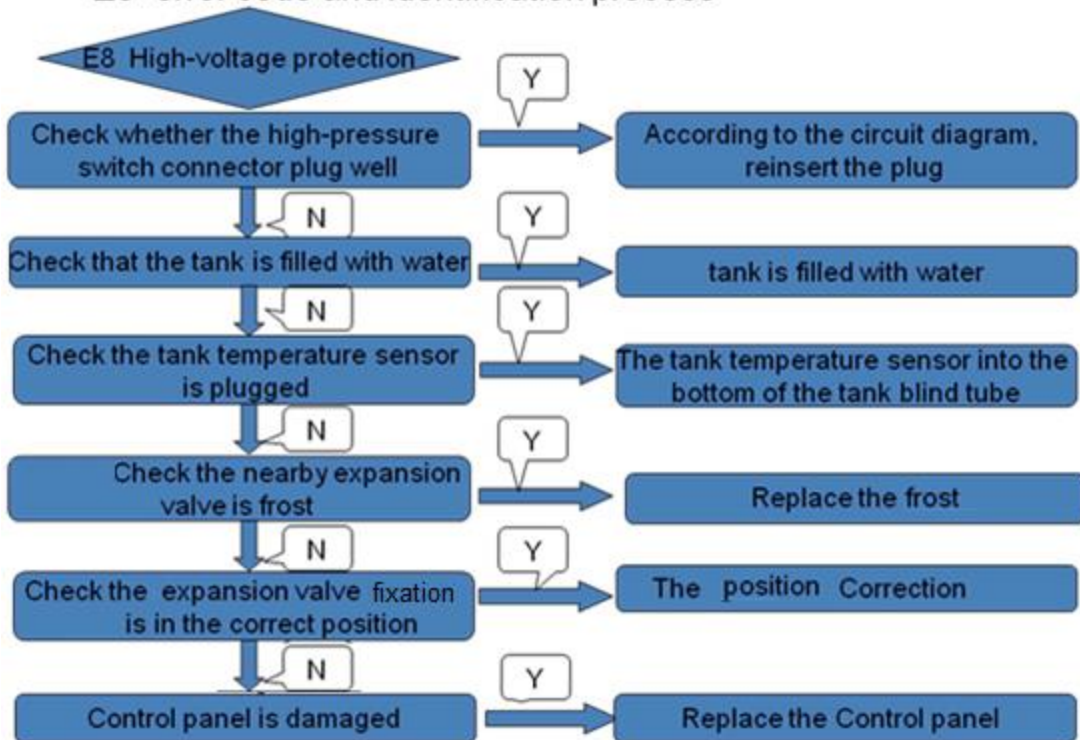

“E9 F2” error code and identification process

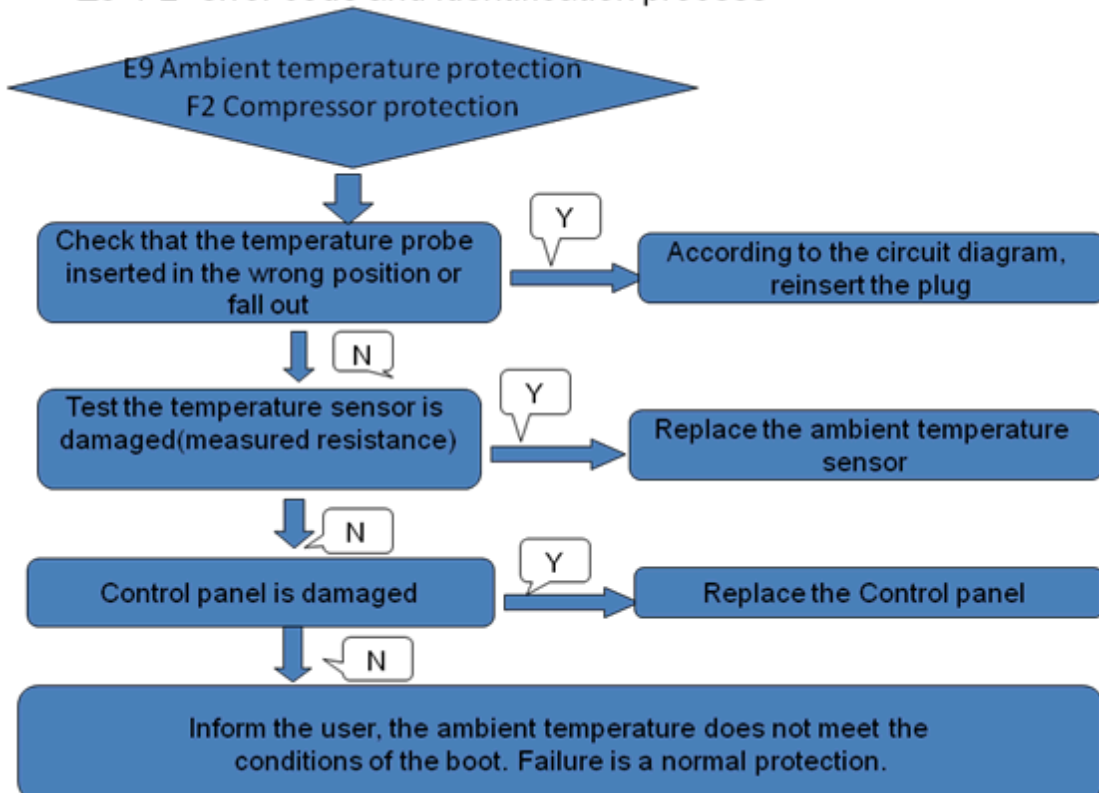

### “F3” error code and identification process

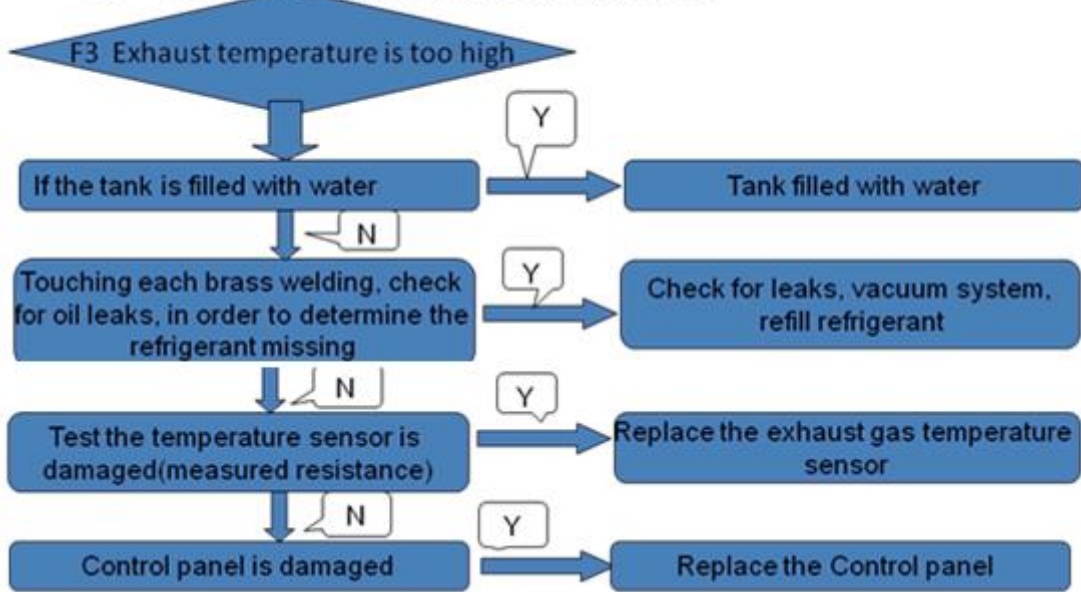

### “F5” error code and identification process

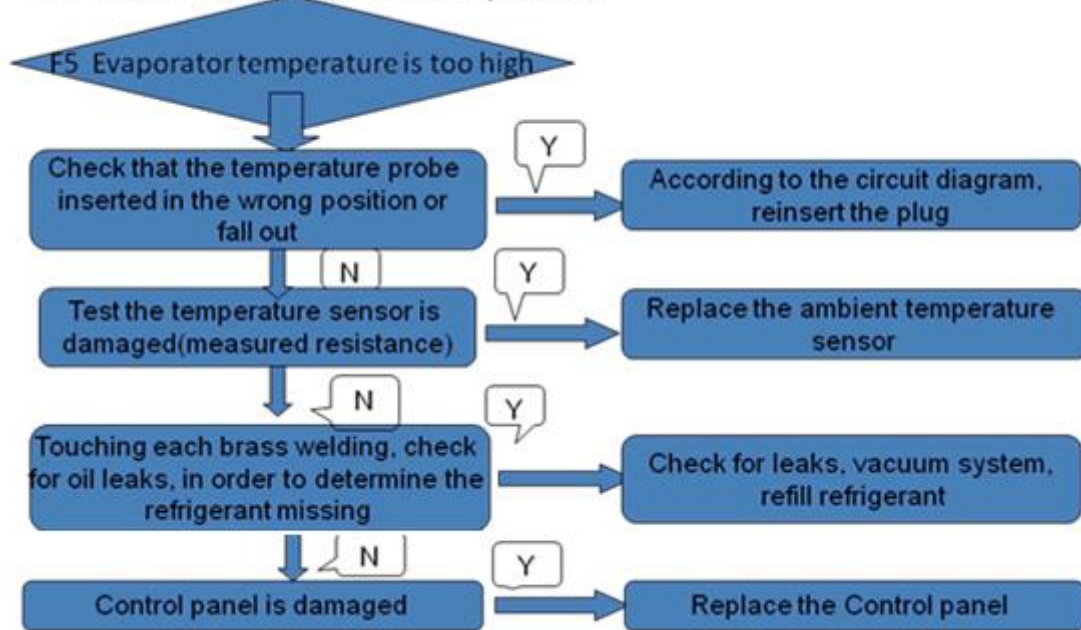

## “F6” error code and identification process

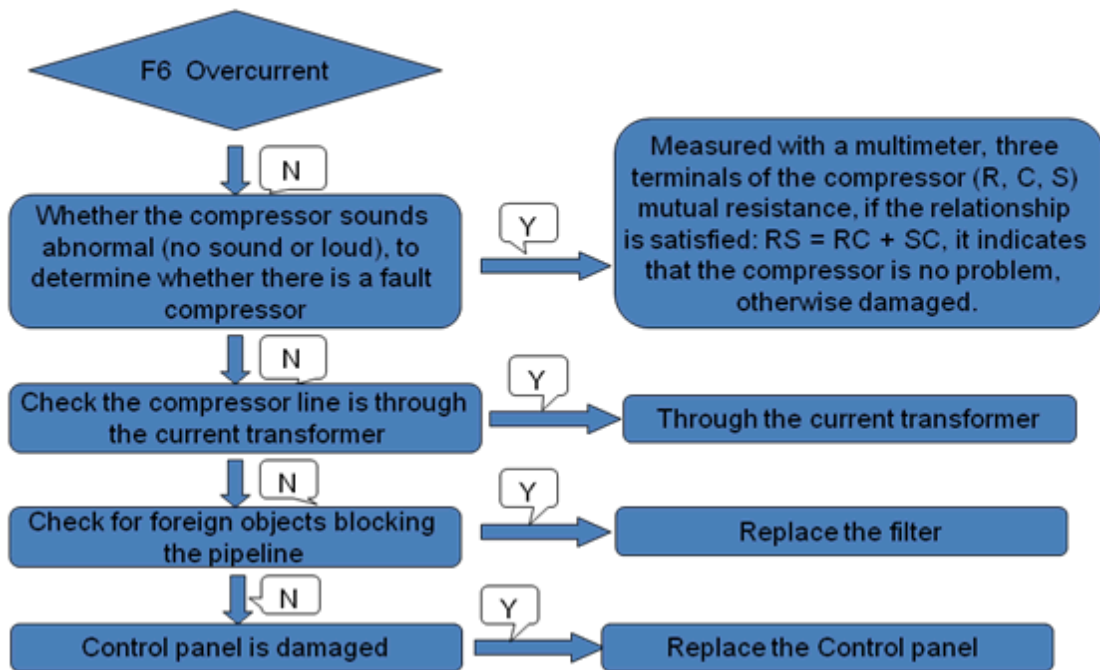

### Temperature sensor resistance measurement method

Temperature sensor resistance measurement method (method of measuring the resistance value of the compressor of the same, but is switched to the small resistance of the interface unit).

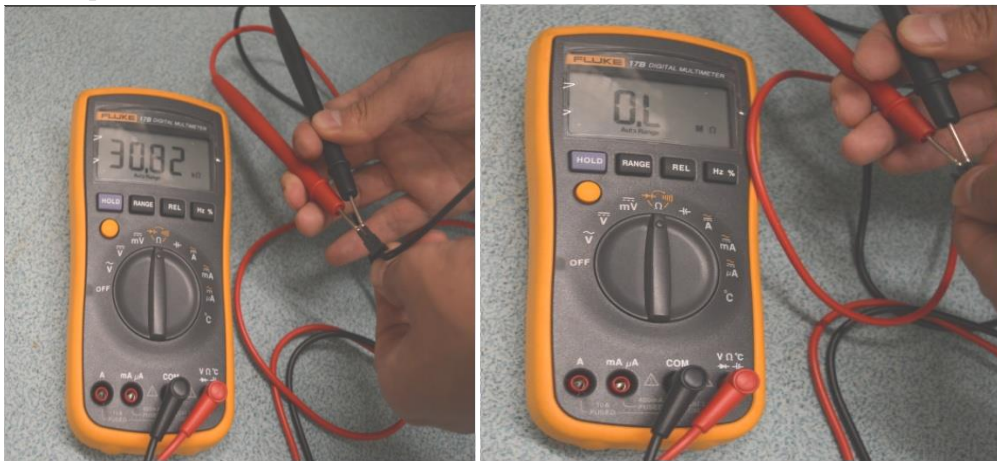

Multimeter set to Ohms, according to the picture of the method of measuring the resistance of the temperature sensor. According to the resistance table, the lower the temperature the smaller the resistance.

**Check the compressor line is through the current transformer**

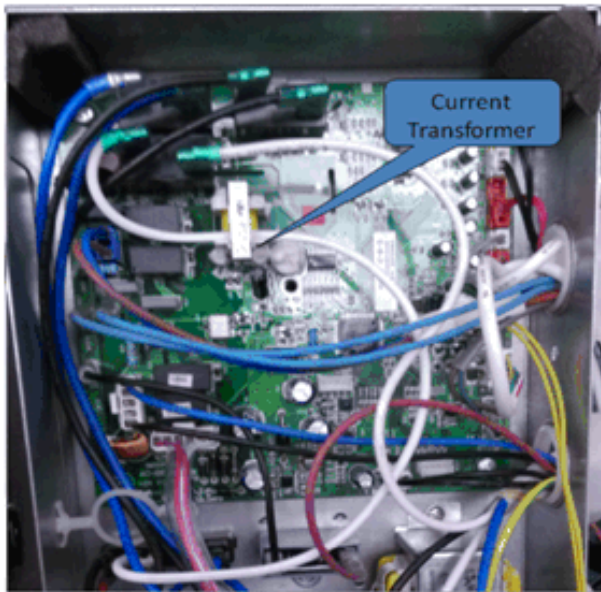

**Check the signal cable is short-circuited**

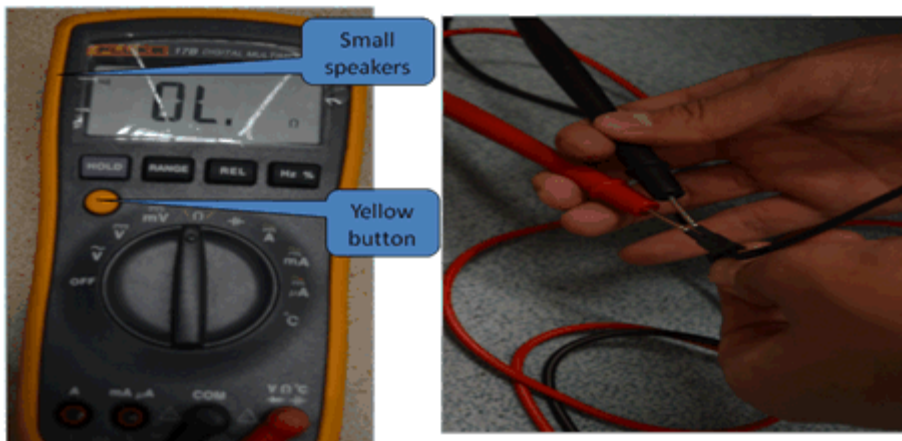

Press the yellow button to switch to the picture, when a short circuit, there is a beep, the resistance is zero.

**Check the tank heater for leaks**

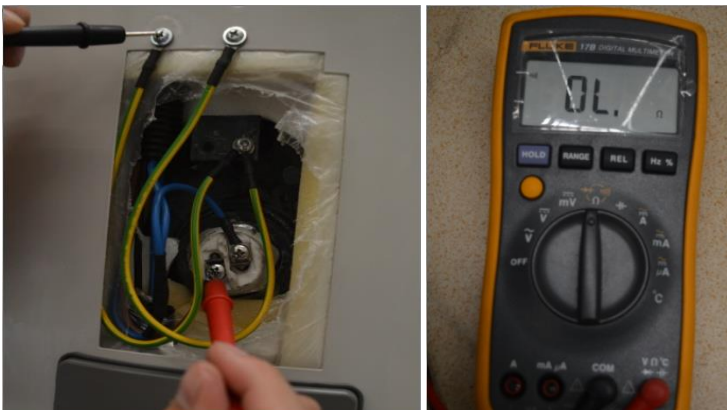

Press the yellow button to switch to the picture shown, turn the heating power measurements, if leakage resistance is zero, if not leak, show resistance.



Check that the power cord L, N lines are in the same order into the leakage protection coil

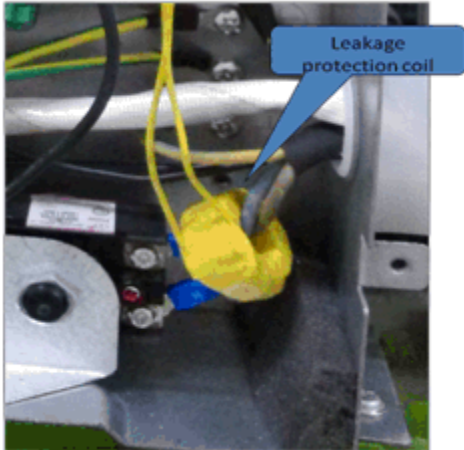

## 9. The method of dismantling products

Make sure the power cord is disconnected.

### 1、 Remove the Display

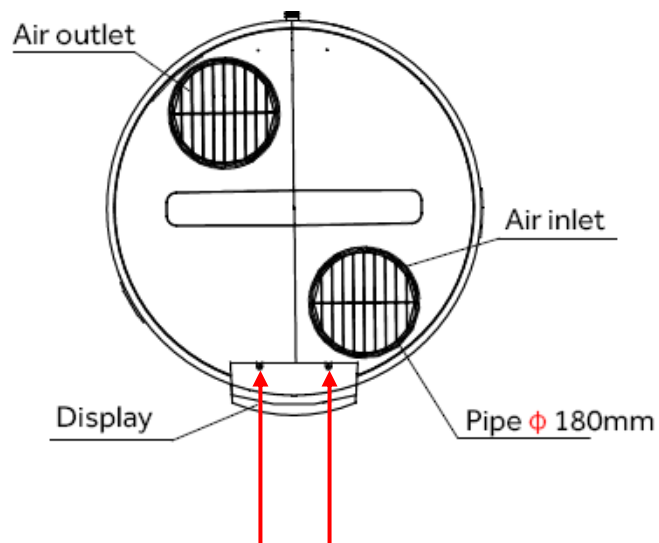

### 2、 Remove the Cover

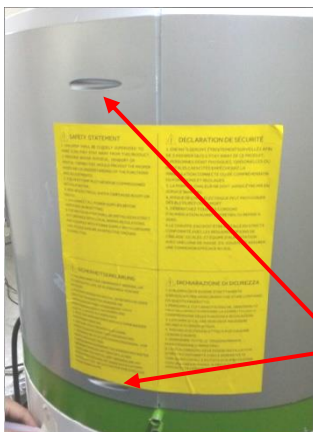

Use a screwdriver to remove the two screws

Use a screwdriver to remove the screws

### 3、 Remove the Air channel and fan

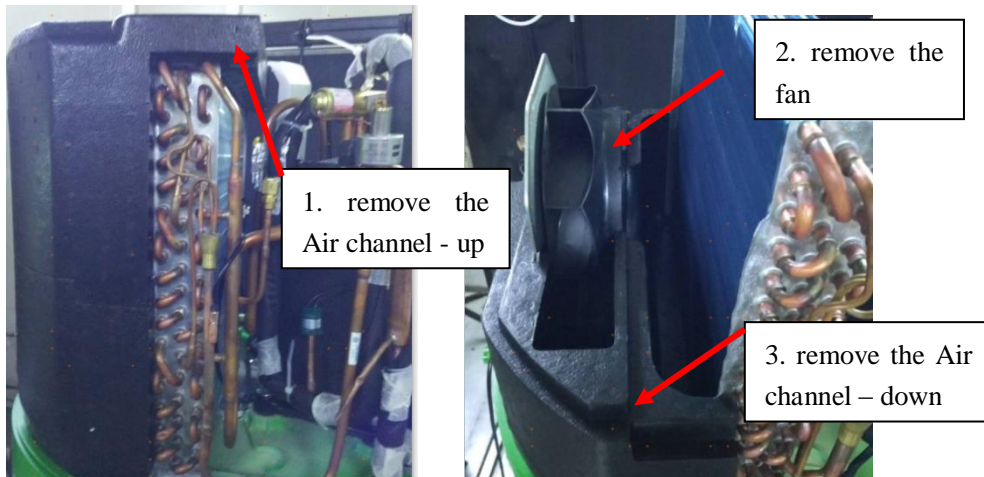

### 4、 Remove the Magnesium rod

Off the power and close the inlet valve, open any outlet valve, exhaust pressure, when no water flows out of time, turn off all the valves.

- ① Remove the magnesium rod cover;
- ② After remove the magnesium rod, according to the consumption of magnesium rod, determine whether you need to replace.

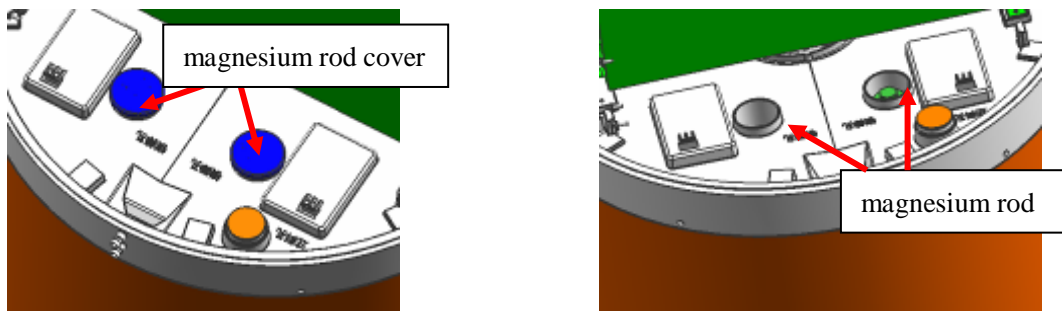

### 5、 Remove the temperature sensor

- ① Remove the fixing screws, remove the water tank flange cover;
- ② Remove the temperature sensors and thermostat temperature sensor.

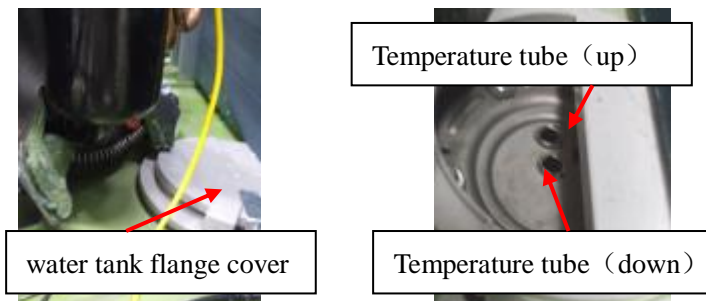

First insert the temperature sensor, and then insert the thermostat temperature sensor to Temperature tube (down) . Temperature sensor must be inserted into the bottom of the tube.

## 6、 Open the control box

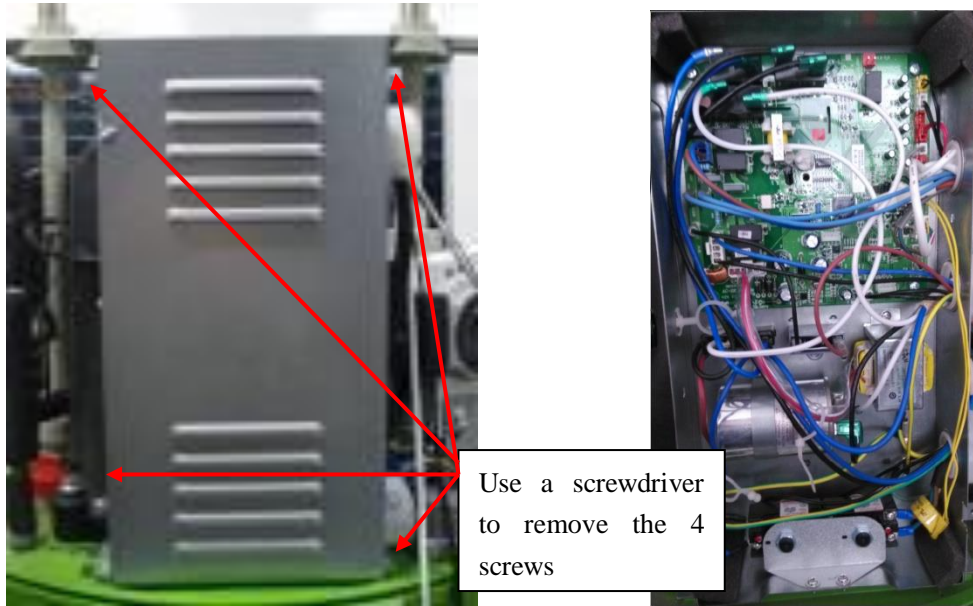

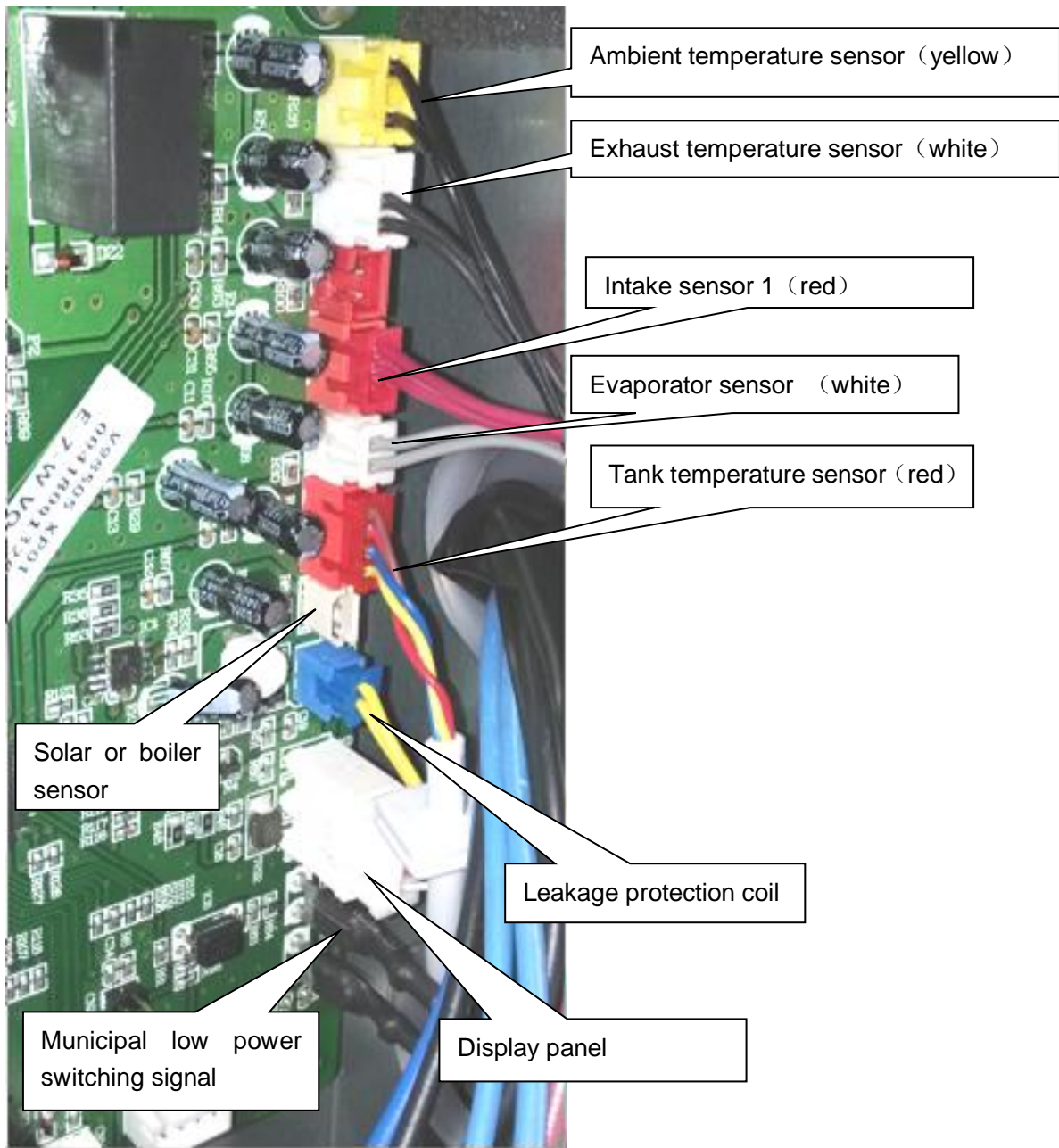

After the Cover is removed, use a screwdriver to remove the bottom two screws of the Front cover – down.

②Remove Electrical cover



Use a screwdriver to remove the 2 screws

③Remove the internal wiring and electric heater

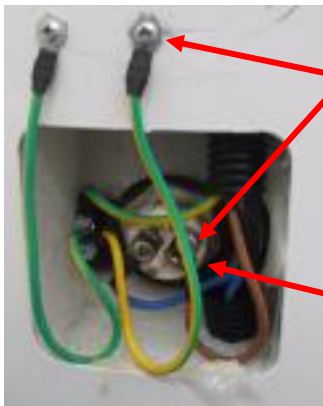

Use a screwdriver to remove the 6 screws.

After the tank has been emptied, with a socket wrench to remove the electric heater.

## 10. The method of Charge of the refrigerant gas

### 1. Check the heat pump system refrigerant leakage method:

1. In the heating process, heat pump input power has remained unchanged;
2. During heating, the temperature of the water in the tank is constant (ensure that the electric heater is not activated).

### 2. Leakage check:

If you have confirmed that the system has been leaked, please check it as follows.

1. Unscrew the maintenance valve nut, access to nitrogen, to maintain pressure 1MPa.
2. Apply soap bubbles evenly over the solder joints of the copper tube. Observe the changes in the status of soap bubbles to determine the location of leakage.
3. After the professionals repair the welding leakage point, check the leakage again with the above method until it is confirmed that the system has no leakage point.

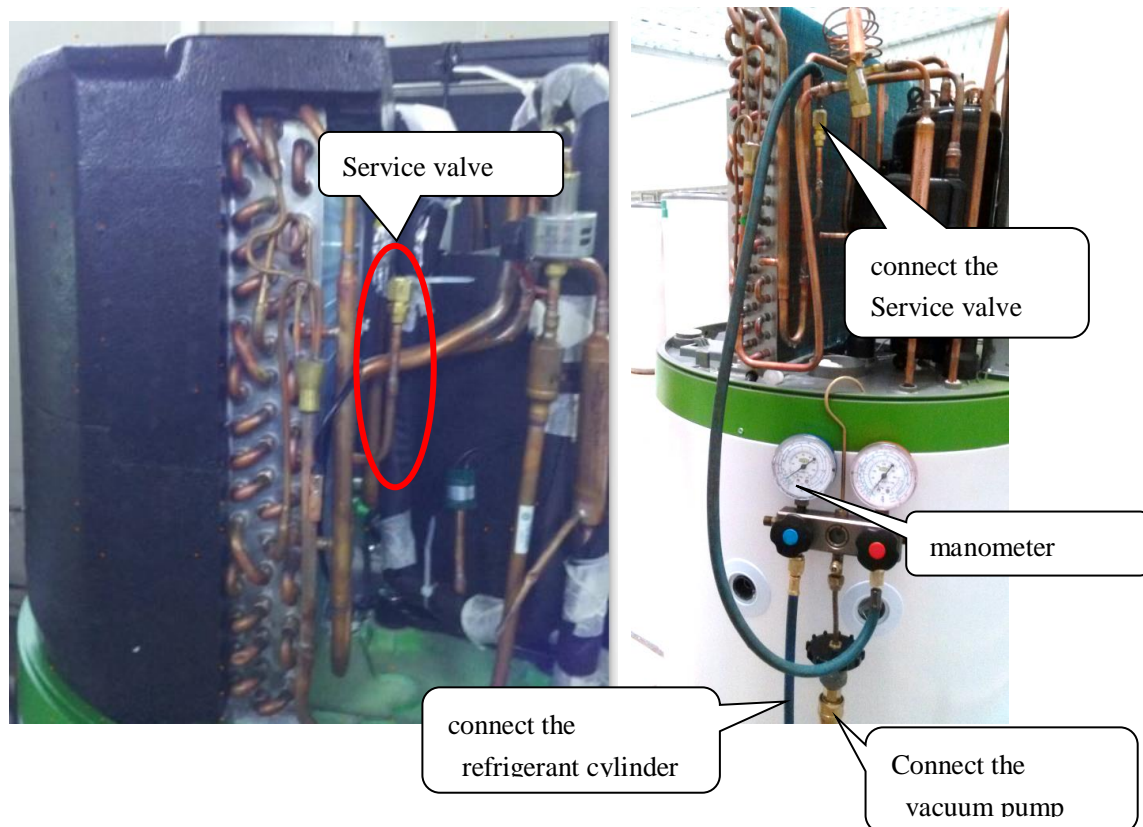

### 3. Making the vacuum & Gas Charging:







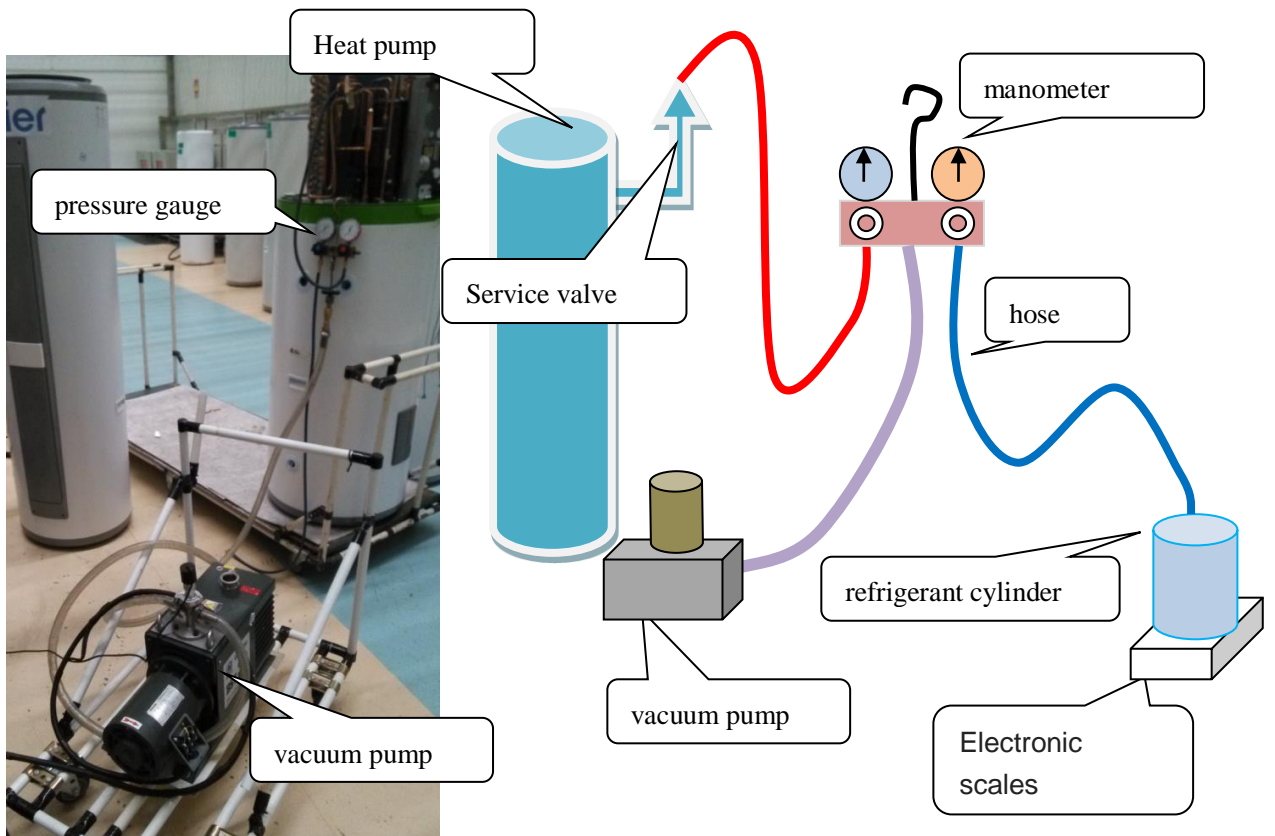

Bleeding from the circuit should take place with a vacuum pump and pressure gauge assembly suitable for R134a.

Make sure the vacuum pump is full of oil up to the level indicated by the oil gauge.

1. Connect the manometer on the low pressure service valve of heat pump, and connect the refrigerant cylinder to the other side the manometer.
2. Connect the vacuum pump to the center tap of the manometer.
3. After opened the valves of the vacuum pump, start it and let it run. Create a vacuum for about 20 / 25 minutes;
4. Close the valves of the pump and shut off. Verify that the gauge needle does not move for about 5 minutes.
5. Disconnect the vacuum pump;
6. Open the container of the refrigerant then open the main valve cap pressure gauge and adjust the needle valve until you hear the coolant leak, and release the pin and close the valve of the pipe;
7. Keep under control the weight of the refrigerant tank through the electronic scale;
8. Open the ball valve and to flow the refrigerant gradually;
9. After reaching the mass of gas to be loaded close the tap(0.9kg);
10. Remove the manometer and charging hose from the valve;
11. turn the product in heat pump mode with the detector and check for leaks of refrigerant;
12. Remove the container from the manifold and replace all the equipment.



## 10. Repairs common tools

Tools Name	Quantity	Illustration
<b>Spanner</b>	<b>2pc</b>	
<b>Hexagon Spanner</b>	<b>1pc</b>	
<b>Flathead screwdriver</b>	<b>1pc</b>	
<b>Phillips screwdriver</b>	<b>1pc</b>	
<b>Needle-nose pliers</b>	<b>1pc</b>	
<b>Measuring tape</b>	<b>1pc</b>	
<b>Pressure gauge</b>	<b>1pc</b>	
<b>Vacuum pump</b>	<b>1pc</b>	
<b>Electronic scale</b>	<b>1pc</b>	
<b>Bending device</b>	<b>1pc</b>	