



# IR-EGGS3 INFRARED EXTENDER



## ENGLISH MANUAL

### Packaging contents:



1x Receiver



1x Cable



1x AC/DC adapter

### Front receiver:



Infrared sensor

### Back receiver:

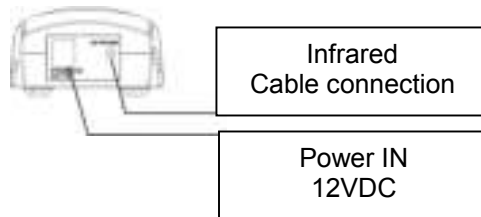

Infrared Cable connection

Power IN 12VDC

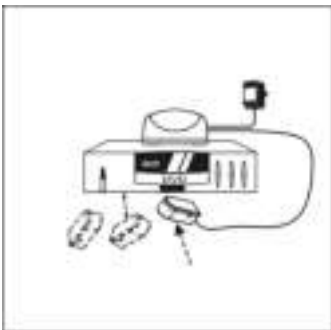

With the IR-EGGS3 it's possible to control equipment in a closed closet.

Place the sensor on the front of e.g. DVD, VCR, SAT receiver, Set Top Box or Home Cinema receiver.

Place the receiver vertical on top of the closet

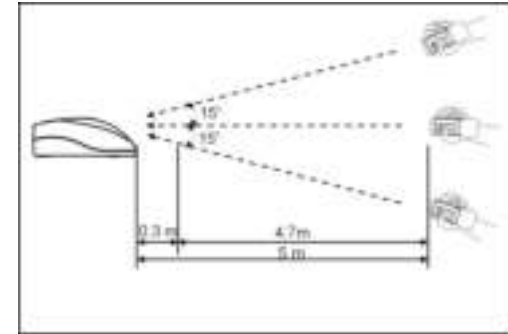

Distance not less than 30cm and not more than 5m. Angle not more than 15°.

### Specifications:

Operating voltage: 120VAC, 60Hz / 230/240 VAC, 50Hz/ 12VDC, 100mA(min)

Power Consumption: 1 Watts (max)

Effective operating range: 5M (min)

Angle: 15°

Infrared Receiver Section: 38 KHz tuning frequency

Sensors: 3

Cable length: 2m

### Warning:

To reduce risk of electric shock, this product should ONLY be opened by an authorized technician if service is required. Disconnect the product from mains and other equipment if a problem should occur. Do not expose the product to water or moisture.

### Warranty:

No guarantee or liability can be accepted for any changes and modifications of the product or damage caused due to incorrect use of this product.

### General:

Designs and specifications are subject to change without a notice.



# IR-EGGS3 INFRAROT EXTENDER



## DEUTSCHE ANLEITUNG

### Lieferumfang:



1x Empfänger



1x Kabel



1x Netzadapter

### Front Empfänger:



Infrarot  
sensor

### Rückseite Empfänger:

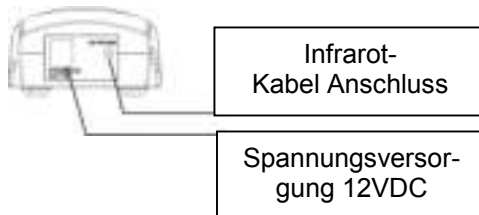

Infrarot-  
Kabel Anschluss

Spannungsversor-  
gung 12VDC

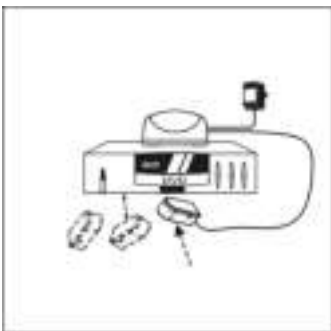

Mit IR-EGGS3 ist die Fernbedienung von Geräten in einem geschlossenen Schrank möglich.

Platzieren Sie die Sensoren vor die Front von z.B. DVD, VCR, SAT-Receiver, Set-Top Box oder Home Cinema Receiver.

Stellen Sie den Empfänger vertikal auf den Schrank.

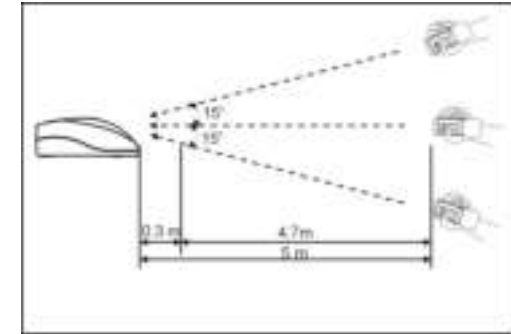

Abstand nicht weniger als 30 cm und nicht mehr als 5m. Winkel nicht größer als 15°.

### Spezifikationen:

Betriebsspannung: 120VAC, 60Hz / 230/240 VAC, 50Hz/ 12VDC, 100mA (min.)

Leistungsaufnahme: 1 Watt (max.)

Effektive Reichweite: 5m (min.)

Winkel: 15°

Infrarot-Empfänger: 38 kHz Abstimmfrequenz

Sensoren: 3

Kabellänge: 2m

### Warnung:

Um die Gefahr eines Stromschlages zu vermeiden, sollte dieses Produkt im Falle eines Defektes NUR von einem autorisierten Techniker geöffnet werden. Trennen Sie das Produkt von Stromkreis und anderen Geräten, sobald ein Problem auftritt.

Vermeiden Sie Kontakt zu Wasser oder hoher Feuchtigkeit.

### Garantie:

Es kann keine Garantie bei Änderungen und Modifikationen oder durch unsachgemäße Handhabung verursachte Schäden übernommen werden.

### Allgemein:

Design und Spezifikation unterliegen der Änderung ohne vorherigen Hinweis.



# IR-EGGS3 TRANSMETTEUR IR



## MANUEL FRANÇAIS

### Contenu de l'emballage:



1x Récepteur



1x Câble



1x Adaptateur AC/DC

### Façade récepteur:



Capteur  
infrarouge

### Arrière récepteur:



Connexion  
infrarouge câble

Power IN  
12VDC

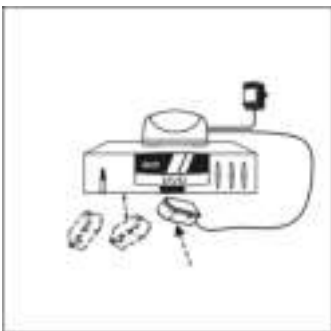

Avec le IR-EGGS3 vous pouvez contrôler l'équipement à l'intérieur des meubles.

Placez le capteur devant, p.e. le DVD, VCR, récepteur SAT, ou récepteur Home Cinema.

Placez le récepteur verticalement en haut du meuble.

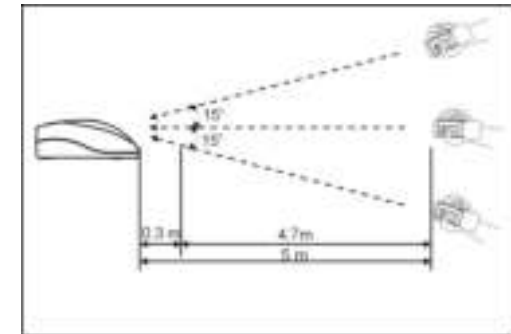

Distance pas moins de 30cm et pas plus de 5m. Pas plus de 15° d'angle.

### Caractéristiques:

Tension de fonctionnement: 120VAC, 60Hz / 230/240 VAC, 50Hz/ 12VDC, 100mA(min)

Consommation: 1 Watt (max)

Plage de fonctionnement effective: 5M (min)

Angle: 15°

Section Récepteur Infrarouge: fréquence 38 KHz

Capteurs: 3

Longueur câble: 2m

### Avertissement:

N'ouvrez pas ce dispositif, ainsi vous éviterez le choc électrique. Aucune pièce susceptible d'être réparée par vos soins ne se trouve à l'intérieur. Tout dépannage doit être effectué par un technicien qualifié !

### Garantie:

Le fabricant ne répond pas des dommages consécutifs à la modification de l'appareil ou à l'utilisation incorrecte de l'appareil, dans ce cas, la garantie n'est plus valable.

### Général:

La conception et les spécifications sont sujettes à des modifications sans avertissement préalable.



## IR-EGGS3 INFRAROOD VERLENGER



NEDERLANDSE  
GEBRUIKSAANWIJZING

### Inhoud verpakking:



1x Ontvanger



1x Kabel



1x AC/DC adapter

### Voorzijde ontvanger:



Infrarood  
sensor

### Achterzijde ontvanger:

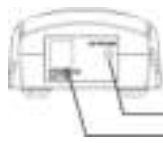

Infrarood  
Kabelaansluiting

Voeding IN  
12VDC

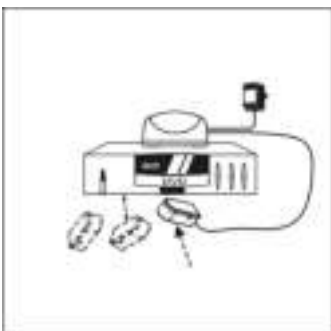

Met de IR-EGGS3 is het mogelijk om apparatuur te bedienen in een gesloten kast.

Plaats de sensor op de voorzijde van bijv. DVD, VCR, Satelliet ontvanger, Set Top Box of Home Cinema versterker.

Plaats de ontvanger op de bovenzijde van de kast.

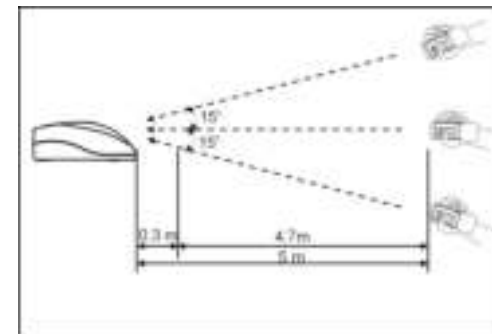

De afstand tussen de afstandsbediening en de ontvanger dient minstens 30cm te zijn. De hoek, om met de afstandsbediening op te ontvanger te richten, is maximaal 15°.

### Specificaties:

Voeding: 120VAC, 60Hz / 230/240 VAC, 50Hz/ 12VDC, 100mA(min)

Verbruik: 1 Watts (max)

Bereik: 5M (min)

Hoek: 15°

Frequentie infrarood: 38 KHz

Sensors: 3

Kabellengte: 2m

### Veiligheidsvoorschriften:

Om het risico van een elektrische schok te voorkomen, mag dit apparaat alleen, indien nodig, geopend worden door een geautoriseerd servicebedrijf. Ontkoppel het apparaat van stroom en randapparatuur, wanneer zich een probleem voordoet.

### Garantie:

Garantie of aansprakelijkheid wordt niet aanvaard als er veranderingen en/of modificaties zijn aangebracht of bij onjuist gebruik van het product.

### Algemeen:

Wijzigingen in uitvoering en specificaties voorbehouden.



# IR-EGGS3 ESTENSORE DI TELECOMANDO



## MANUALE ITALIANO

### Contenuto:



1x Ricevitore



1x Cavo



1x AC/DC adattatore

### Frontale ricevitore:



Sensore  
infrarosso

### Retro ricevitore:

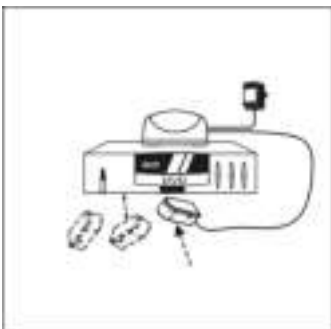
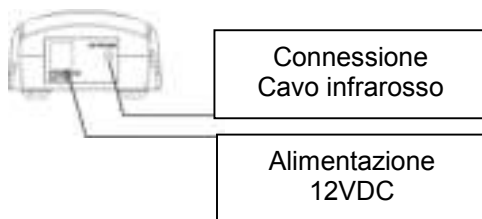

Grazie allo IR-EGGS3 è possibile controllare un apparecchio che si trova dentro un armadietto chiuso.

Posizionare il sensore di fronte, per esempio, al lettore DVD, videoregistratore, ricevitore satellitare o Set Top Box, o ricevitore di un sistema Home Cinema.

Posizionare il ricevitore verticalmente, sopra all'armadietto.

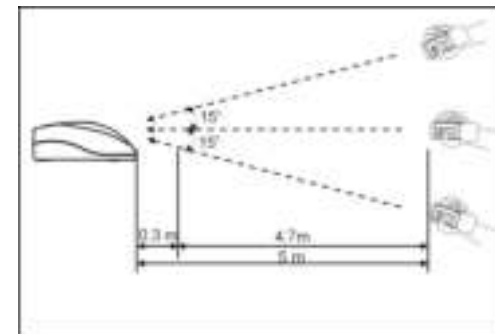

Distanza non inferiore a 30cm e non superiore a 5m. Angolo non superiore a 15 gradi.

### Specifiche:

Tensione operativa: 120VAC, 60Hz / 230/240 VAC, 50Hz/ 12VDC, 100mA(min)

Consumo: 1 Watt (max)

Portata operativa effettiva: 5m (min)

Angolo: 15°

Sezione ricevitore ad infrarossi: frequenza di sintonizzazione 38 KHz

Sensori: 3

Lunghezza del cavo: 2m

### Attenzione:

Per ridurre il rischio di scariche elettriche, questo prodotto deve essere aperto SOLO da un tecnico autorizzato, nel caso sia necessario un intervento di manutenzione. Se dovesse verificarsi un problema, staccare il prodotto dalla corrente e da altri equipaggiamenti. Non esporre il prodotto all'acqua o all'umidità.

### Garanzia:

Non si prestano garanzie né si accettano responsabilità per qualsiasi modifica o cambiamento del prodotto o per danni causati da un uso scorretto di questo prodotto.

### Generalità:

Progetti e specifiche sono soggetti a cambiamenti senza preavviso.



# IR-EGGS3 EXTENSOR DE INFRARROJOS



## MANUAL EN ESPAÑOL

### Contenido de la caja:



1 receptor



1 cable



1 adaptador CA/CC

### Parte frontal del receptor:



Sensor  
infrarrojo

### Parte posterior del receptor:

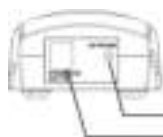

Conexión de cable  
para infrarrojo

Entrada (IN) de  
alimentación  
12V CC

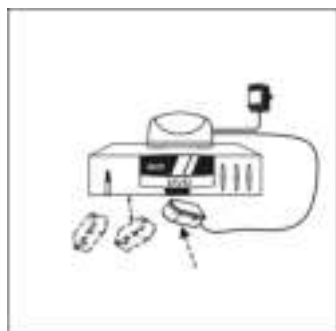

Con el IR-EGGS3 se pueden controlar equipos que se encuentran en un armario cerrado.

Coloque el sensor delante del DVD, video, receptor SAT, receptor Set-Top Box o de Cine en Casa.

Coloque el receptor verticalmente encima del armario.

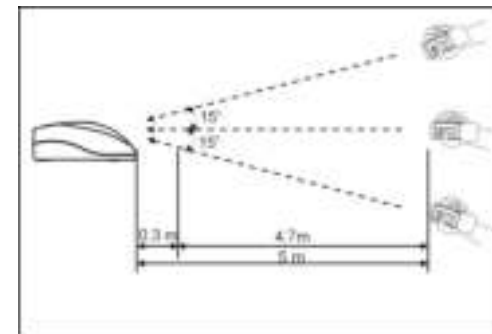

Distancia mínima: 30 cm. Distancia máxima: 5 m. Angulo no más de 15°.

### Especificaciones:

Tensión de funcionamiento: 120V CA, 60Hz / 230/240 V CA, 50Hz/ 12V CC, 100 mA (mín)

Consumo eléctrico: 1 W (máx.)

Alcance efectivo: 5 m (mín.)

Angulo: 15°

Sección de receptor infrarrojo: Frecuencia de sintonización 38 KHz

Sensores: 3

Longitud de cable: 2 m

### ¡Atención!

Para reducir el riesgo de descargas eléctricas, este equipo ÚNICAMENTE debe ser abierto por personal cualificado. En caso de fallo, desconéctelo de la red y de otros aparatos. No exponga el aparato al agua o humedad.

### Garantía:

No se acepta responsabilidad alguna por cambios y modificaciones del producto o daños causados debido a su uso incorrecto.

### General:

Los diseños y especificaciones están sujetos a cambios sin preaviso.



# IR-EGGS3 Infravörös hosszabbító



## Magyar leírás

### A csomag tartalma:



1x Vevő



1x kábel



1x AC/DC adapter

### Első vevő:



Infravörös  
szenzor

### Hátsó vevő:



Infravörös  
kábelcsatlakozás

Power IN  
12VDC

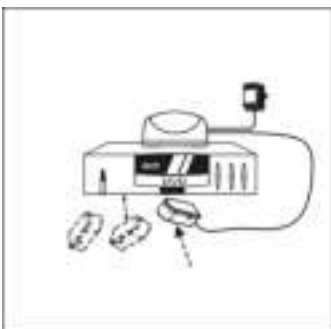

Az IR-EGGS3 segítségével zárt helységekből is lehetséges a szabályzás.

Helyezze a szenzort a . DVD, VCR, SAT vevő, Set Top Box vagy házi mozi első szektorára.

Helyezze a vevőt függőlegesen.

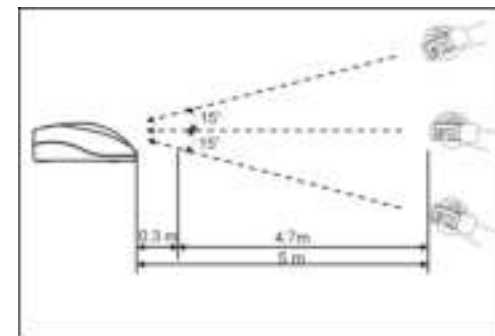

A táv ne legyen kevesebb mint 30cm és ne legyen több mint 5m. A rálátási szög max. 15°.

### Adatok::

Áramerősség: 120VAC, 60Hz / 230/240 VAC, 50Hz/ 12VDC, 100mA(min)

Energiafelhasználás: 1 Watt (max)

Hatósugár: 5M (min)

Szög: 15°

Infravörös szektor: 38 KHz frekvencia

Szor: 3

Kábelhossz: 2m

### Figyelem:

A készüléket az áramütés veszélyének elkerülése végett kizárólag hozzá értő, szakavatott szakember nyissa meg.. Amennyiben probléma készül merül fel a készüléknél kösse le az áramról. Ne tegye ki por és víz hatásának.

### Garancia:

A termék külső-belső struktúrájában okozott változást követően a garancia érvényét veszti..

### Általános:

A formaterv és a műszaki tartalom változtatása lehetséges.



# IR-EGGS3 INFRARÖD FÖRLÄNGARE



## SVENSK MANUAL

### Innehåll :



1xMottagare



1x Kabel



1x AC/DC adapter

### Front mottagare:



Infraröd  
sensor

### Bak mottagare:



Infraröd  
kabel ingång

Strömförsörjning in  
12VDC

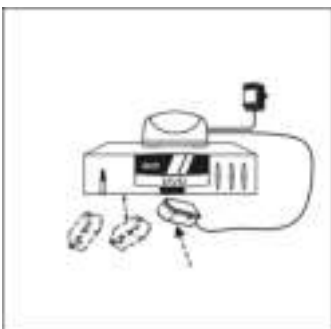

Med IR-EGGS3 är det möjligt att styra din utrustning i en sluten stereobänk eller hylla.

Placera sensorn framför DVD, VCR, SAT ir öga,

Placera mottagaren ovanpå bänken eller hyllan.

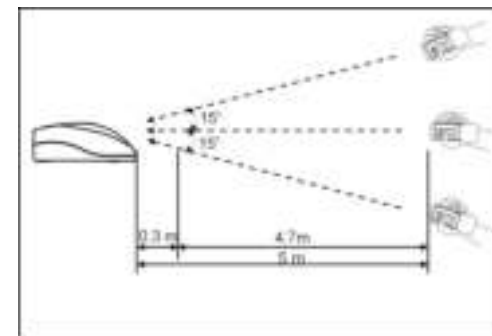

Avstånd ej mindre än 30 cm , ej mer än 5 m.  
Vinkel ej mer än 15°.

### Specifikationer:

Strömstyrka: 120VAC, 60Hz / 230/240 VAC, 50Hz/ 12VDC, 100mA(min)

Strömförbrukning: 1 Watts (max)

Operations radie: 5M (min)

Vinkel: 15°

Infraröd mottagning: 38 KHz frekvens

Sensorer: 3

Kabel längd: 2m

### Varning:

För att minska risken för elektrisk chock, så får denna apparat endast öppnas av en auktoriserad serviceman. Koppla ur strömförsörjningen om ett problem skulle inträffa. Utsätt ej apparaten för vatten eller väta.

### Garanti:

Ingen garanti gäller eller ansvar tages vid gjorda ändringar eller modifieringar eller skada uppkommen av inkorrekt användande av produkten.

### Övrigt:

Design och specifikationer kan ändras utan notifiering.





# IR-EGGS3 INFRAPUNA LAAJENNIN



## KÄYTTÖ-OHJE

### Pakkauksen sis.:



1x vastaanotin



1x johto



1x virtalähde

### Vastaanottimen etuosa:



IR-  
anturi

### Takaosa:

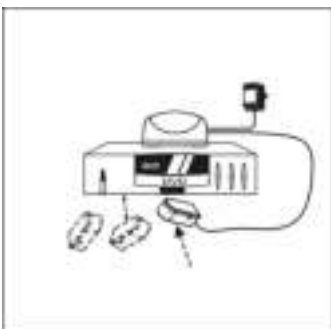
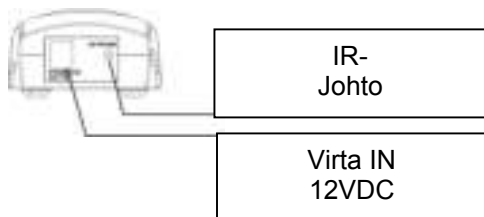

IR-EGGS3 :lla on mahdollista kaukosäätää laitteita, jotka ovat suljetussa kaapissa.

Aseta anturi DVD, VCR, SAT virittimen jne....etuosaan.

Aseta vastaanotin hyllyn päälle.

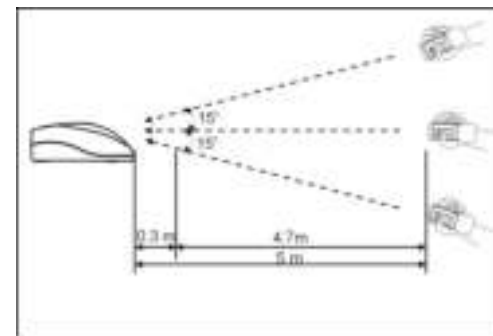

Aseta anturi säädettävästä laitteesta 0,3m – 5m, kulma max. 15°.

### Tekniset tiedot:

Toiminta jännite: 120VAC, 60Hz / 230/240 VAC, 50Hz/ 12VDC, 100mA(min)

Tehon kulutus: 1 Watts (max)

Tehokas toim.alue: 5m (min)

Kulma: 15°

Infrapuna vastaanotin: 38 KHz viritystaajuus

Anturit: 3

Johdonpituus: 2m

### TURVALLISUUSOHJEET:

Jos laite tarvitsee huoltoa, sen saa avata ainoastaan valtuutettu huoltoteknikko, asiantuntematon käsittely aiheuttaa sähköiskun vaaran. Irrota laite virtalähteestä, jos sen käytössä ilmenee ongelmia. Suojaa vedeltä ja kosteudelta.

### TAKUU:

Takuuvastuu ja korvausvelvollisuus eivät kata sellaista tuotetta, johon on tehty muutoksia tai jota on käsitelty asiaankuulumattomalla tavalla.

### YLEISTÄ:

Valmistaja voi muuttaa laitteiden malleja ja ominaisuuksia ilman ennakoilmoitusta.



# IR-EGGS3 SADA PRO PŘENOS IR SIGNÁLŮ



## NÁVOD K POUŽITÍ

### Balení obsahuje:



1x přijímač



1x kabel s IR čidly



1x AC/DC zdroj

### Čelní strana přijímače:



IR  
přijímací  
čidlo

### Zadní strana přijímače:



Konektor pro kabel  
s IR čidly

12VDC  
napájení

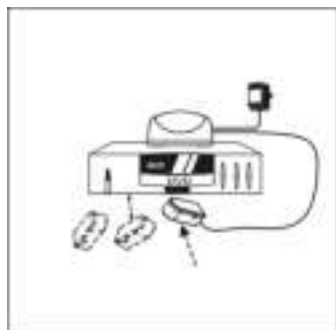

Se sadou IR-EGGS3 je možné ovládat AV zařízení uzavřená ve skřínce nebo jinak nepřístupná pro IR signál dálkového ovládání.

Natočte IR čidlo na zařízení (DVD, VCR, SAT přijímač, DVBT přijímač či systém domácího kina)

Přijímač umístěte vertikálně na viditelném

vyvýšeném místě.

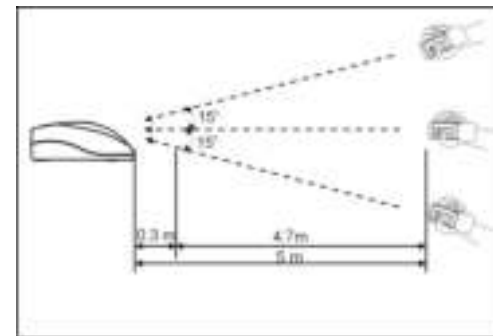

Vzdálenost nesmí být menší než 30 cm a větší než 5 m s náklonem do 15°.

### Specifikace:

Provozní napětí: 120VAC, 60Hz / 230/240 VAC, 50Hz/ 12VDC, 100mA(min)

Spotřeba energie: 1 W (max)

Efektivní dosah příjmu z DO: 5m (min)

Přijímací úhel: 15°

IR nosná frekvence: 38 KHz

Počet čidel: 3

Délka kabelu: 2m

### BEZPEČNOSTNÍ UPOZORNĚNÍ

Pro minimalizaci nebezpečí úrazu elektrickým proudem může zařízení opravovat POUZE autorizovaný servis. Pokud dojde k závadě neprodleně odpojte výrobek od napájení a připojených zařízení. Nevystavujte výrobek nadměrné vlnosti.

### ZÁRUKA

Záruka nebude přiznána v případě, pokud dojde k úpravám výrobku nebo pokud dojde k nesprávnému používání.

### Všeobecná ustanovení:

Výrobce si vyhrazuje právo změn v provedení a specifikaci bez předchozího upozornění.