

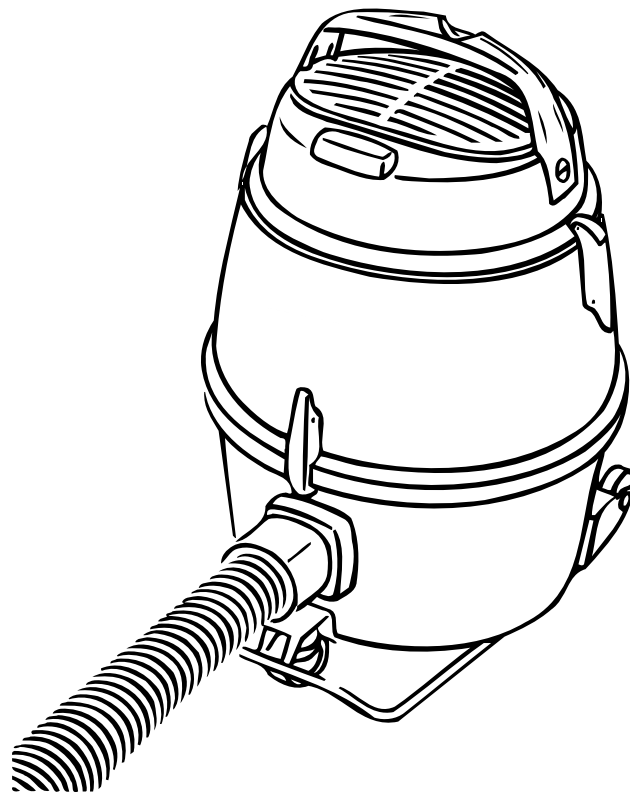

GM 80

User manual

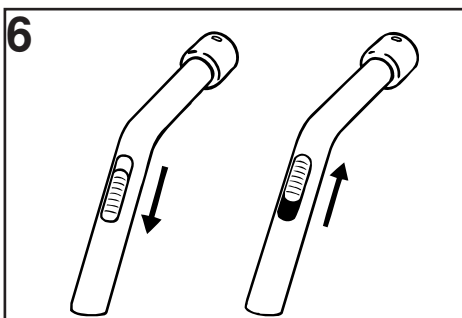

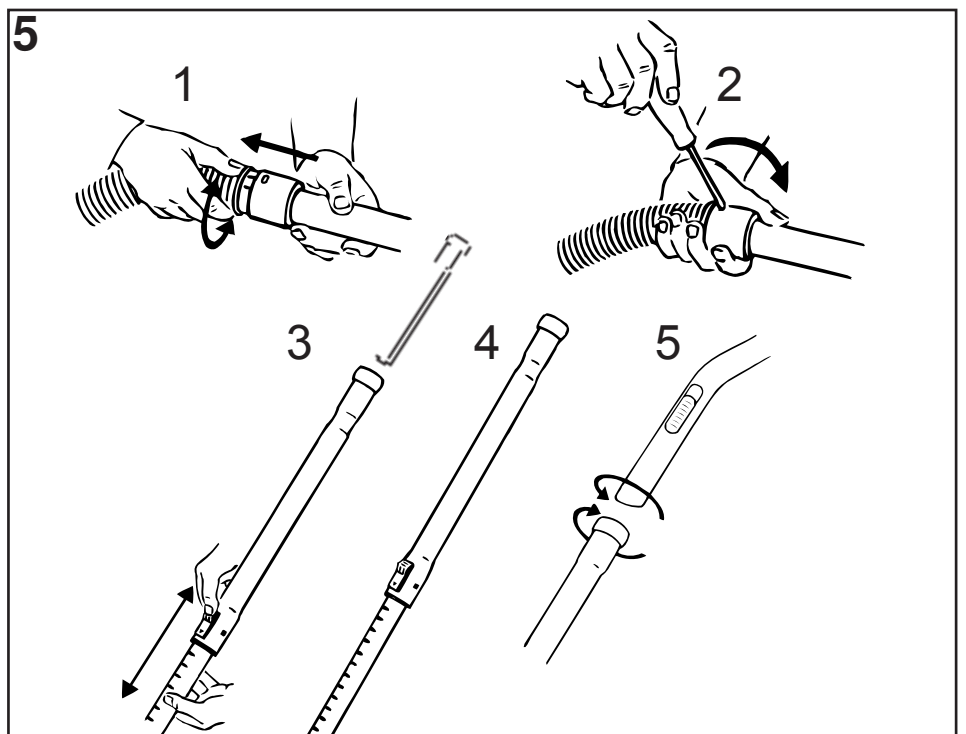
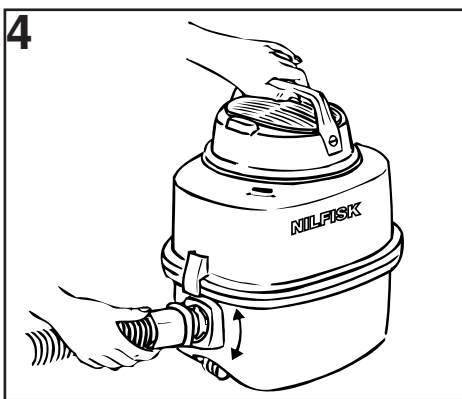
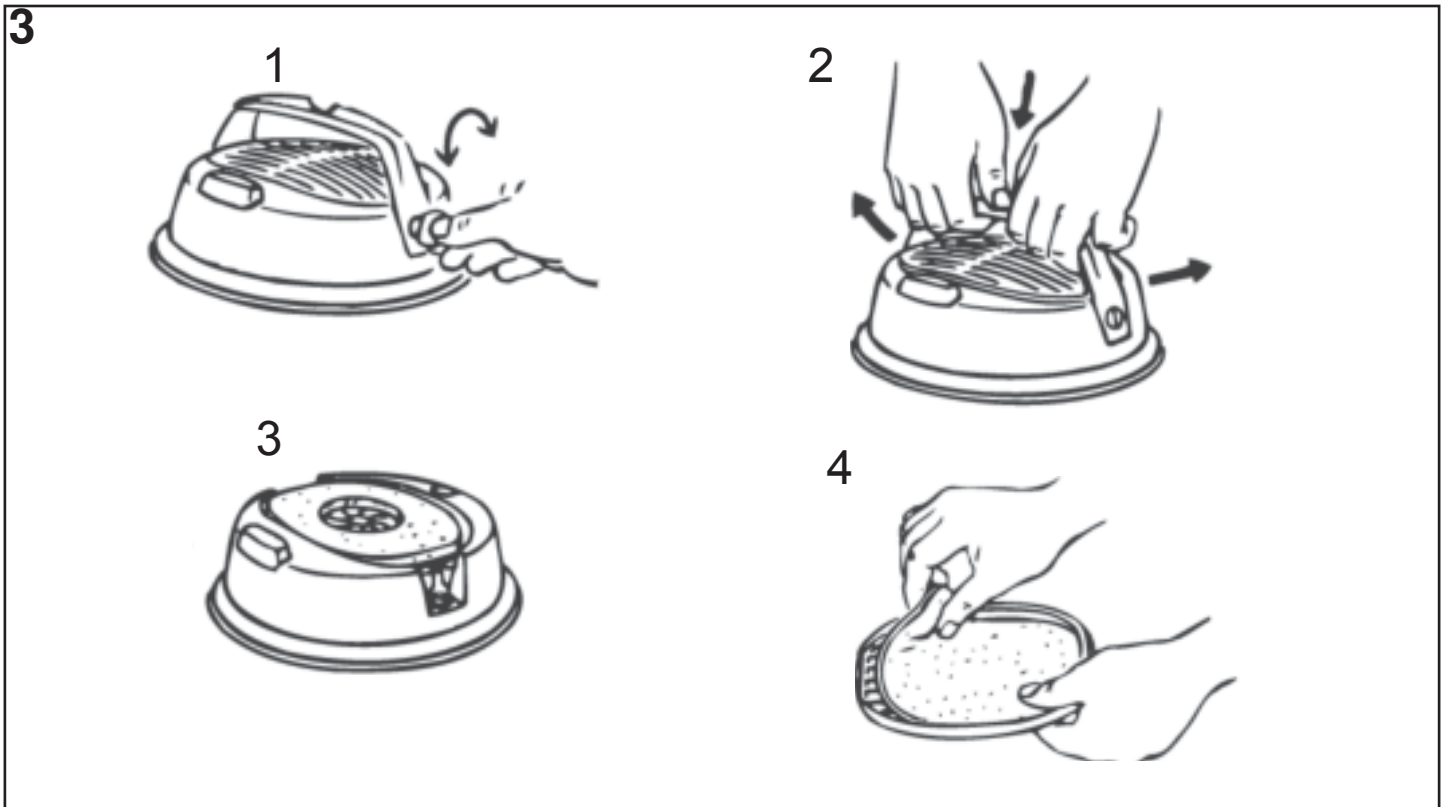
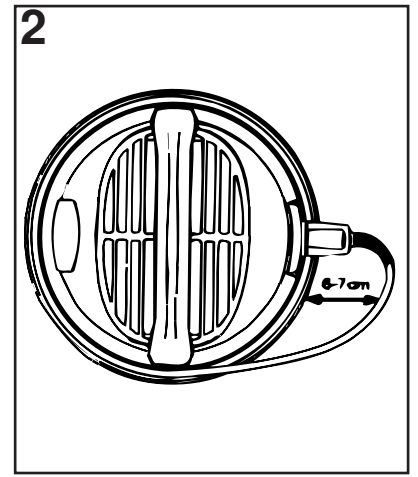
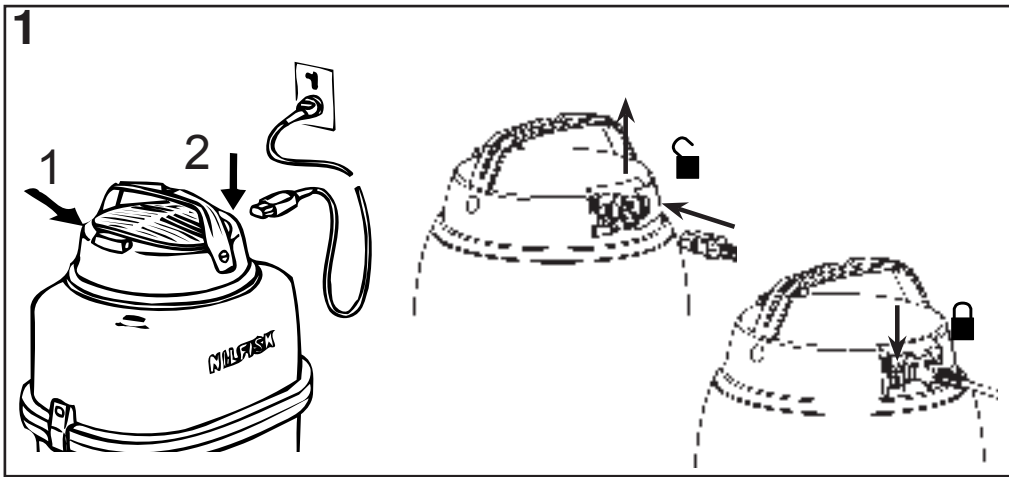

7

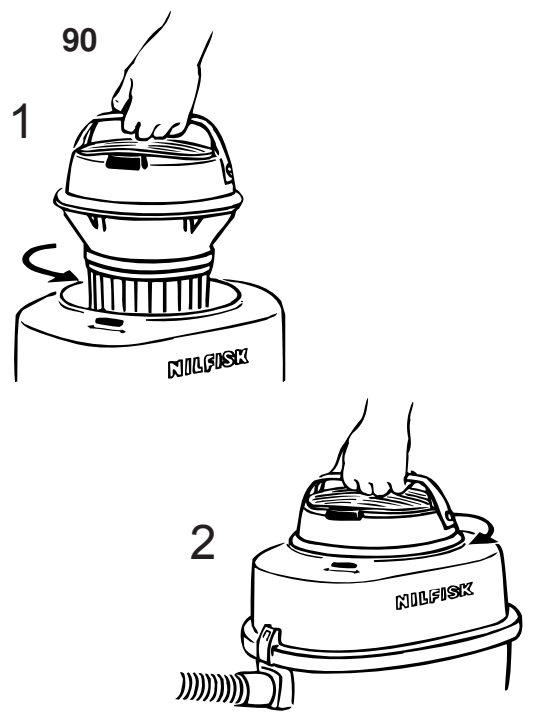
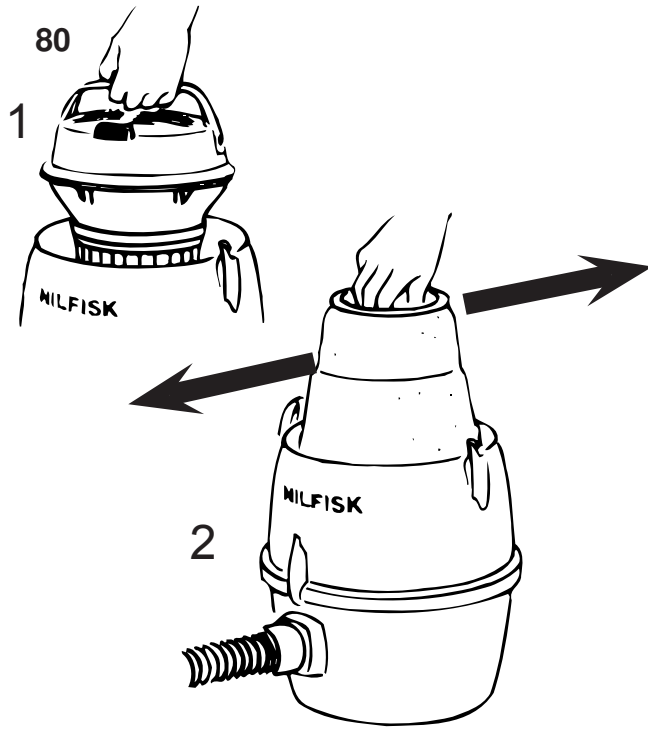

8



9

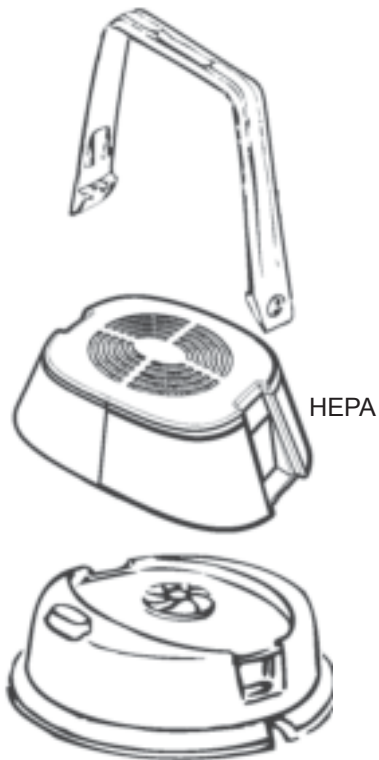

10

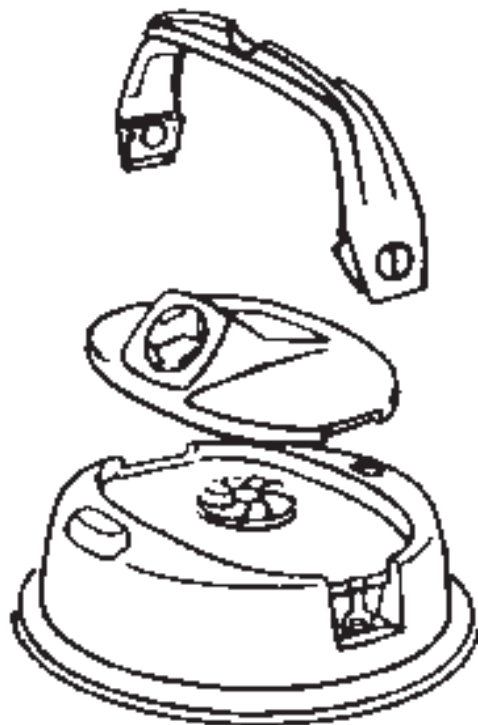

Ⓧ	Brugsanvisning	6 - 10
Ⓧ	Bruksanvisning	9 - 11
Ⓧ	Driftsinstruks	12 - 14
Ⓧ	Käyttöohje.....	15 - 17
Ⓧ	Instructions for use	18 - 20
Ⓧ	Bedienungsanleitung	21 - 24
Ⓧ	Mode d'emploi	25 - 27
Ⓧ	Gebruiksaanwijzing	28 - 31
Ⓧ	Instrucciones de utilización.....	32 - 35
Ⓧ	Instruções de utilização	36 - 39
Ⓧ	Istruzioni per l'uso.....	40 - 43
Ⓧ	Οδηγίες χρήσης	44 - 45
	Data	46 - 48
	Weee	49 - 50
	CE Declaration	51 - 53

Instructions for use

Before the vacuum cleaner is ready for use, the hose must be fitted to the curved tube as described under point 5.

Before using the vacuum cleaner make sure that the voltage shown on the rating plate corresponds with the mains voltage.

The vacuum cleaner is supplied with a paper dust bag already in place. Never use the vacuum cleaner without a properly fitted dust bag. The procedure for replacing the dust bag is described under point 8.

Important Warnings

1. This machine is also suitable for normal housekeeping purposes in hotels, schools, hospitals, factories, shops and offices.
2. This machine is not suitable for picking up health endangering dust.
3. This machine is for dry use only and shall not be used or stored outdoors in wet conditions. Store indoors between max. 60 C (degrees centigrade) and min. 0 C (degrees centigrade).
4. The machine for vacuum dry dust must not be used for the suction of water or other liquids.
5. The machine must not be used for picking up combustible or explosive materials, nor should it be used in an explosive atmosphere.
6. Under no circumstances should the machine be used for picking up hot material. In particular the machine must not be used for cleaning open

and closed fireplaces, ovens or similar that contain warm or glowing ashes.

7. The machine must not be used if the electrical cord shows any sign of damage. Regularly inspect the cord for damage, in particular if it has been crushed, shut in a door or run over. A detachable supply cord with integrally molded plugs must not be repaired. It has to be replaced by a new supply cord supplied by Nilfisk if the cable or plugs are damaged.
8. The machine must not be used if it is faulty.
9. Do not unplug by pulling on cord. To unplug, grasp the plug, not the cord.
10. When repairing or replacing the cord, the same type of cord as originally supplied with the machine must be used. This cord can be supplied by Nilfisk.
11. The plug must always be removed from the socket outlet before starting any service work of the machine or the cord.
12. Repair of the electrical unit with motor or the cord must only be carried out by a skilled or instructed person after having disconnected the main switch installed prior to the machine or after having removed the plug from the current socket.
13. No changes or modifications to the mechanical or elec-

trical safety devices should be made.

14. This appliance can be used by children aged from 8 years and above and persons with reduced physical, sensory or mental capabilities or lack of experience and knowledge if they have been given supervision or instruction concerning use of the appliance in a safe way and understand the hazards involved.

15. Children shall be supervised to make sure that they do not play with the appliance.

16. Cleaning and user maintenance shall not be made by children without supervision.

1 Starting / stopping

1. Place the appliance plug of the cable in the motor socket. Plug the cable into the wall socket.

Press button 1. to start the motor
Press button 1. again to stop it.

After cleaning, unplug the cable from the wall socket.

Detaching the power cord

To prolong the life of your cord, detach it from the motor each time after cleaning, roll it up loosely and store it.

2 Note

Do not roll the cord tightly around the motor as this will place a strain on the cord and considerably shorten its life.

3 Micro-Static Filter

The grey Micro-Static filter on the top of the motor attracts and retains micro-particles efficiently. In order to ensure a constant cleaning of the exhaust air and to avoid overheating of the motor, it is essential that the filter is replaced regularly. The Micro-Static filter should be replaced after approx. 50 hours use, equivalent to one year of domestic use.

Replacing

1. Turn the two screws with a coin until their slots are vertical.

2. Release the handle by a gentle downward pressure at its centre. Press until both ends spring out from the motor recess.
3. Lift off the exhaust grill and the filter. The sound absorbent material must remain on top of the motor.
4. Remove the grey filter and mount the new one. Replace the grill. Locate the handle into position and lock it by turning the screws until their slots are horizontal.

4 Hose connection

Insert the bayonet coupling into the suction inlet, and lock it in place by turning it clockwise. Reverse this procedure to disconnect the hose.

5 Hose and tubes

1. Fitting hose to the curved tube
Slide the hose into the curved tube and adjust by turning until locking levers grip into position.
2. Removing hose from curved tube
You may wish to remove the hose from the curved tube so that you can easily remove a blockage.

Push one of the locking levers with a screwdriver, as illustrated. Tip the locking lever until it is released. Repeat on the other locking lever. The curved tube can now be separated from the hose.

Models with telescopic tube

The telescopic tube can be adjusted to suit your height.

3. Unlock the tube as illustrated in the diagram and pull to the desired length.
4. Lock the tube as illustrated.

All models

5. Slide the curved tube into the steel tube.

6 Suction power regulation

1. The suction power of the nozzle can be regulated by the slide valve on the curved tube. Suction is most powerful when the valve is pushed forward to close the inlet.
2. For cleaning of e.g. loose covers and curtains, the suction power can be reduced by sliding the valve backwards.

7 Shaking the filter

To keep suction power at a constant level the filter must be kept as clean as possible by shaking it at regular intervals.

The filter must not be washed or brushed.

Removing the motor 80

1. Hold the motor handle and open the top catches.

Lift off the motor.

2. Pull out the filter by its bottom plate and shake it gently from side to side. The hose must remain fixed to the container during the shaking operation. The filter can be cleaned by vacuum it.

Removing the motor 90

1. Dismantle the motor by turning its handle anticlockwise. Lift off the motor.

Emptying the container

When the filter has been shaken and the hose detached, release the two latches and open the container. Lift off the top part and empty the lower part of the container.

Replacing the motor 80

When mounting the motor make sure that the switch is directly over the suction inlet of the container and the plug is turned backwards.

Replacing the motor 90

2. Reset the motor so that the on/off switch is opposite the motor mounting mark on the container and the plug is turned backwards. Turn the motor clockwise until a distinct click is heard. If the motor will not lock into position by turning, then press the red locking lever inside the container in the direction of the arrow.

8 Suction with dust bag

The cleaner is supplied with a two-ply self-locating dust bags. To release the container, unfasten the two latches and lift off the upper part with the motor/filter section. Fix the dust bag as follows:

1. Pierce the dust bag's perforation and place it in the lower container.
2. Pull the dust bag plastic plate over the suction inlet with both hands. Unfold the dust bag carefully. Replace the top container and lock the two latches.

Note

The suction efficiency depends on the size and quality of the dust bag. Use original Nilfisk bags only. If non-Nilfisk dust bags are used, and airflow restricted, overheating of the motor and subsequent damage may result.

9 Exhaust filter

Exhaust filters is used when absolutely clean exhaust air is necessary. The exhaust filter is mounted on to the motor in place of the diffuser. The exhaust filter is easily fitted and the filter element is replaceable. A special handle is delivered together with the exhaust filter.

10 Blowing attachment

Mounting

Remove the diffuser and sound absorber (see page 2)

Place the blowing adaptor 11562000 on the motor. Each one is kept in place by handle of the motor.

Fit the blowing attachment into the motor blowing adaptors.

Before connecting a hose make sure that it is clean - place its open end in the container inlet for a moment with the motors running and shake it.

Maintenance

Always keep the cleaner in a dry place. The bearings in the motor are pregreased and designed for continuous heavy work.

Depending on the number of running hours the dust filter should be replaced.

For details of service or maintenance please contact Nilfisk directly.

Rating Plate

The model and serial number of your machine are shown on the ratingplate on the machine. This information is needed when ordering repair for the machine. Use the space below to note the model and serial number of your machine for future reference.

Model

Serial number

Year of manufacture

Powering voltage

Trouble-shooting

- **the motor will not start**
 - a fuse may have blown and needs replacing.
 - the cable or the wall socket may be defective and needs checking.
- **the suction power is reduced**
 - the dust bag may be full and needs replacing, see page 3.
 - the filter may be clogged and needs shaking, see page 3.
- **the motor will not stay locked in position on the container. Only 90**
 - The red locking lever in the container top is in the wrong position. Push the lever in the direction of the arrow.

DATA

ENGLISH SPECIFICATIONS		GM 80 220-240V	GM 80 110-120V	GM 80 100V	G/GM 90 220-240V	G/GM 90 110-120V	G/GM 90 100V
Rated power	W	1200	1100	850	1200	1100	850
Max. power	W	1300	1200	950	1300	1200	950
Protection grade (moist., dust)	-	IP40	IP40	IP40	IP40	IP40	IP40
Protection class (electrical)	-						
Airflow with hose and tube	l/sec	38	38	33	38	38	33
Vacuum	kPa	20	20	18	20	20	18
Suction power with hose	W	270	250	200	270	250	200
Sound pressure level at 1.5 m (ISO 11203)	-	-	-	-	-	-	-
a) Vacuum cleaner+nozzle	dB(A)/20µPa	63	63	63	63	63	63
b) Vacuum cleaner	dB(A)/20µPa	61	61	61	61	61	61
Main filter small	cm ²	-	-	-	800	800	800
Main filter large	cm ²	2100	2100	2100	2200	2200	2200
Main filter material	type	Cotton	Cotton	Cotton	Cotton	Cotton	Cotton
Exhaust filter, HEPA, surface area	cm ²	3300	3300	3300	3300	3300	3300
Container capacity	l	12.25	12.25	12.25	14.5	14.5	14.5
Weight	kg	5	5	5	5	5	5

Specifications and details are subject to change without prior notice.

DEUTSCH SPEZIFIKATIONEN		GM 80 220-240V	GM 80 110-120V	GM 80 100V	G/GM 90 220-240V	G/GM 90 110-120V	G/GM 90 100V
Leistungsaufnahme Motor	W	1200	1100	850	1200	1100	850
Leistungsaufnahme Motor, max.	W	1300	1200	950	1300	1200	950
Schutzklasse (Feucht., Staub)	-	IP40	IP40	IP40	IP40	IP40	IP40
Schutzklasse (elektrisch)	-						
Luftmenge mit Schlauch	l/Sek.	38	38	33	38	38	33
Unterdruck	kPa	20	20	18	20	20	18
Saugleistung mit Schlauch	W	270	250	200	270	250	200
Schalldruckpegel in 1,5m Abstand (ISO 11203)	-	-	-	-	-	-	-
a) Staubsauger mit Schlauch	dB(A)/20µPa	63	63	63	63	63	63
b) Staubsauger ohne Schlauch	dB(A)/20µPa	61	61	61	61	61	61
Hauptfilterfläche, kleine	cm ²	-	-	-	800	800	800
Hauptfilterfläche, groß	cm ²	2100	2100	2100	2200	2200	2200
Hauptfilter material		Baumwolle	Baumwolle	Baumwolle	Baumwolle	Baumwolle	Baumwolle
Abluftfilter, HEPA, Fläche	cm ²	3300	3300	3300	3300	3300	3300
Behälter Kapazität	l	12,25	12,25	12,25	14,5	14,5	14,5
Masse (Gewicht)	kg	5	5	5	5	5	5

Technische Änderungen vorbehalten.

FRANÇAIS CARACTÉRISTIQUES TECHNIQUES		GM 80 220-240V	GM 80 110-120V	GM 80 100V	G/GM 90 220-240V	G/GM 90 110-120V	G/GM 90 100V
Consommation normalisée	W	1200	1100	850	1200	1100	850
Consommation maximale	W	1300	1200	950	1300	1200	950
Indice de protection (humidité, poussière)	-	IP40	IP40	IP40	IP40	IP40	IP40
Classe de protection électrique	-						
Débit d'air avec flexible	l/s	38	38	33	38	38	33
Aspiration	kPa	20	20	18	20	20	18
Puissance d'aspiration avec flexible	W	270	250	200	270	250	200
Niveau sonore à 1.5 m (ISO 11203)	-	-	-	-	-	-	-
a) aspirateur avec flexible et embouchure	dB(A)/20µPa	63	63	63	63	63	63
b) aspirateur seul	dB(A)/20µPa	61	61	61	61	61	61
Petit filtre principal	cm ²	-	-	-	800	800	800
Grand filtre principal	cm ²	2100	2100	2100	2200	2200	2200
Matière du filtre		Coton	Coton	Coton	Coton	Coton	Coton
Superficie du filtre HEPA	cm ²	3300	3300	3300	3300	3300	3300
Capacité de la cuve	litres	12,25	12,25	12,25	14,5	14,5	14,5
Poids de l'appareil	kg	5	5	5	5	5	5

Les caractéristiques des matériaux peuvent être modifiées à tout moment, en fonction de l'évolution technique.

NEDERLANDS TECHNISCHE GEGEVENS		GM 80 220-240V	GM 80 110-120V	GM 80 100V	G/GM 90 220-240V	G/GM 90 110-120V	G/GM 90 100V
Stroomverbruik motor	W	1200	1100	850	1200	1100	850
Opgenomen vermogen, max.	W	1300	1200	950	1300	1200	950
Veiligheidsklasse (vocht, stof)	-	IP40	IP40	IP40	IP40	IP40	IP40
Veiligheidsklasse (elektrisch)	-						
Luchtstroom met slang	l/sec	38	38	33	38	38	33
Vacuümdruk	kPa	20	20	18	20	20	18
Zuigkracht met slang	W	270	250	200	270	250	200
Geluidsniveau op 1,5 m (ISO 11203)	-	-	-	-	-	-	-
a) Stofzuiger + mondstuk	dB(A)/20µPa	63	63	63	63	63	63
b) Stofzuiger	dB(A)/20µPa	61	61	61	61	61	61
Oppervlakte hoofdfilter, klein	cm ²	-	-	-	800	800	800
Oppervlakte hoofdfilter, groot	cm ²	2100	2100	2100	2200	2200	2200
Materiaal hoofdfilter		katoen	katoen	katoen	katoen	katoen	katoen
Afzuigfilter, HEPA, oppervlakte	cm ²	3300	3300	3300	3300	3300	3300
Inhoud stofbak	liter	12,25	12,25	12,25	14,5	14,5	14,5
Gewicht	kg	5	5	5	5	5	5

Specificaties en details kunnen zonder voorafgaande mededeling worden gewijzigd.

WEEE (Waste of Electric and Electronic Equipment)



Symbolet,  som findes på produktet eller emballagen, viser, at produktet ikke må bortskaffes sammen med almindeligt husholdningsaffald. Det skal derimod afleveres på en miljøstation, som er godkendt til håndtering af elektrisk og elektronisk udstyr. Sørg for at bortskaffe produktet korrekt, så du kan være med til at forebygge skader på miljøet og menneskers sundhed. Hvis du ønsker yderligere oplysninger om, hvordan produktet genvindes, kan du henvende dig hos kommunen, en miljøstation eller forretningen, hvor du købte produktet.



The symbol  on the product or on its packing indicates that this product may not be treated as household waste. Instead it shall be handed over to the applicable collection point for the recycling of electrical and electronic equipment. By ensuring this product is disposed of correctly, you will help prevent potential negative consequences for the environment and human health, which could otherwise be caused by inappropriate waste handling of this product.

For more detailed information about recycling of this product, please contact your local city office, your household waste disposal service or the shop where you purchased the product.



Le symbole  sur le produit ou sur son emballage indique que ce produit ne doit pas être traité comme un déchet ménager. Il doit au contraire être remis au point de collecte correspondant pour le recyclage du matériel électrique et électronique. En procédant de cette manière, vous aiderez à prévenir les conséquences potentiellement négatives pour l'environnement et la santé humaine que pourrait causer un traitement inadéquat du rejet de ce produit. Pour plus ample information sur le recyclage de ce produit, veuillez prendre contact avec votre bureau municipal, votre service de collecte de déchets ménagers ou le magasin où vous avez acheté le produit.



Il simbolo  sul prodotto o sulla confezione indica che questo prodotto non può essere smaltito fra i rifiuti domestici. Deve invece essere consegnato a un centro di raccolta autorizzato per il riciclaggio dei dispositivi elettrici ed elettronici. Smaltendo questo prodotto in modo corretto, si contribuisce a ridurre l'impatto ambientale e sull'uomo. Per maggiori informazioni sul riciclaggio di questo prodotto, contattare il proprio comune, il centro di raccolta dei rifiuti urbani locale o il rivenditore.



Het symbool  op het product of de verpakking geeft aan dat dit product niet als huishoudelijk afval mag worden behandeld. Het apparaat moet bij een verzamelpunt voor het recyclen van elektrische en elektronische apparatuur worden ingeleverd. Door dit product op de juiste manier af te danken, helpt u bij het voorkomen van mogelijke negatieve consequenties voor het milieu en de menselijke gezondheid. Deze zouden kunnen ontstaan als dit product niet op de juiste manier wordt behandeld. Voor uitgebreide informatie over het recyclen van dit product kunt u contact opnemen met uw plaatselijke stadskantoor, uw afvalverwerkingsdienst of de winkel waar u het product hebt gekocht.





Tuotteessa tai pakkauksessa oleva symboli  ilmaisee, että tuotetta ei voi hävittää talousjätteen mukana. Sen sijaan tuote on vietävä sähköisten ja elektronisten laitteiden kierrätykseen tarkoitettuun keräyspisteeseen. Kun huolehdit tuotteen asianmukaisesta hävittämisestä, autat edistämään ympäristön ja ihmisten hyvinvointia, jonka tuotteen virheellinen hävittäminen voi vaarantaa. Lisätietoa tämän tuotteen kierrättämisestä saat jätteenkäsittelypalvelusta tai samasta liikkeestä, josta ostit tuotteen.





Das Symbol  auf dem Produkt bzw. auf der Produktverpackung deutet an, dass das Produkt nicht mit dem Haushaltsmüll entsorgt werden darf. Stattdessen ist es zur Entsorgung an eine geeignete Sammelstelle für das Recycling von elektrischen und elektronischen Geräten zu bringen. Durch die korrekte Entsorgung helfen Sie mit, potenziellen negativen Einflüssen auf die Umwelt und die Gesundheit vorzubeugen, die durch eine unangemessene Entsorgung dieses Produktes entstehen könnten. Genauere Informationen zur Wiederverwertung dieses Produktes erhalten Sie von Ihrer Stadtverwaltung, der Müllabfuhr vor Ort oder dem Geschäft, in dem Sie dieses Produkt erworben haben.



Symbolet  på produktet eller emballasjen indikerer at dette produktet ikke kan behandles som husholdningsaffald. I stedet skal det leveres til aktuelt innsamlingspunkt for resirkulering av elektrisk og elektronisk utstyr. Ved å sørge for at dette produktet kasseres korrekt, bidrar du til å forebygge mulige negative følger for miljøet og folks helse, hvilket ellers kan forårsakes ved feilaktig avfallshåndtering av dette produktet. For nærmere informasjon om resirkulering av dette produktet, vennligst kontakt din lokale representant, renholdsverket eller butikken der du kjøpte produktet.

CE	EU Declaration of Conformity
Product:	Vacuum cleaner
Type:	GM 80
The design of the unit corresponds to the following pertinent regulations:	EC - Machinery Directive 2006/42/EC EC - Directive EMC 2004/108/EC EC - RoHS Directive 2011/65/EC
Applied harmonised standards:	EN 60335-2-69:2009 EN 55014-1:2006, EN 55014-2:2001, EN 61000-3-2:2006, EN 61000-3-3:2008, EN 62233:2008
Applied international standards and technical specifications:	DIN EN 60335-2-69:2010
Name and address of the person authorised to compile the technical file:	Anton Sørensen General Manager, Technical Operations EAPC Nilfisk-Advance A/S Sognevej 25 DK-2605 Brøndby
Identity and signature of the person empowered to draw up the declaration on behalf of the manufacturer:	 Anton Sørensen General Manager, Technical Operations EAPC Nilfisk-Advance A/S Sognevej 25 DK-2605 Brøndby
Place and date of the declaration:	Hadsund, 01.10.2013

CE	Déclaration CE de conformité
Produit :	Aspirateur
Modèle :	GM 80
La construction de cette unité est conforme aux réglementations pertinentes suivantes :	Directive machine CE 2006/42/CE Directive CEM CE 2004/108/CE Directive RoHS CE 2011/65/CE
Normes harmonisées appliquées :	EN 60335-2-69:2009 EN 55014-1:2006, EN 55014-2:2001, EN 61000-3-2:2006, EN 61000-3-3:2008, EN 62233:2008
Normes internationales appliquées et caractéristiques techniques :	DIN EN 60335-2-69:2010
Nom et adresse de la personne autorisée à compiler le fichier technique :	Anton Sørensen Directeur général, Opérations techniques EAPC Nilfisk-Advance A/S Sognevej 25 DK-2605 Brøndby
Identité et signature de la personne habilitée à faire la déclaration au nom du fabricant :	 Anton Sørensen General Manager, Technical Operations EAPC Nilfisk-Advance A/S Sognevej 25 DK-2605 Brøndby
Lieu et date de la déclaration :	Hadsund, 01.10.2013

CE	EU-Konformitätserklärung
Produkt:	Staubsauger
Typ:	GM 80
Die Konstruktion dieses Geräts entspricht den folgenden einschlägigen Richtlinien:	EU-Maschinenrichtlinie 2006/42/EG EU-Richtlinie zur elektromagnetischen Verträglichkeit 2004/108/EG EU-RoHS-Richtlinie 2011/65/EU
Angewandte harmonisierte Normen:	EN 60335-2-69:2009 EN 55014-1:2006, EN 55014-2:2001, EN 61000-3-2:2006, EN 61000-3-3:2008, EN 62233:2008
Angewandte internationale Normen und technische Daten:	DIN EN 60335-2-69:2010
Name und Anschrift der Person, die berechtigt ist, die technischen Unterlagen zusammenzustellen:	Anton Sørensen General Manager, Technical Operations EAPC Nilfisk-Advance A/S Sognevej 25 DK-2605 Brøndby
Identität und Unterschrift der Person, die zur Ausstellung dieser Erklärung im Namen des Herstellers berechtigt ist:	 Anton Sørensen General Manager, Technical Operations EAPC Nilfisk-Advance A/S Sognevej 25 DK-2605 Brøndby
Ort und Datum der Erklärung:	Hadsund, 01.10.2013

CE	EU Verklaring van overeenstemming
Product:	Stofzuiger
Type:	GM 80
Het ontwerp van de unit stemt overeen met de volgende geldende bepalingen:	EU Machinerichtlijn 2006/42/EG EU EMC Richtlijn 2004/108/EG EU RoHS-Richtlijn 2011/65/EG
Toegepaste geharmoniseerde normen:	EN 60335-2-69:2009 EN 55014-1:2006, EN 55014-2:2001, EN 61000-3-2:2006, EN 61000-3-3:2008, EN 62233:2008
Toegepaste internationale normen en technische specificaties:	DIN EN 60335-2-69:2010
Naam en adres van de persoon die is bevoegd tot het samenstellen van de technische gegevens:	Anton Sørensen General Manager, Technical Operations EAPC Nilfisk-Advance A/S Sognevej 25 DK-2605 Brøndby
Identiteit en handtekening van de persoon die namens de fabrikant gerechtigd is om de verklaring op te stellen:	 Anton Sørensen General Manager, Technical Operations EAPC Nilfisk-Advance A/S Sognevej 25 DK-2605 Brøndby
Plaats en datum van de verklaring:	Hadsund, 01.10.2013

Nilfisk

<http://www.nilfisk.com>

HEAD QUARTER

DENMARK

Nilfisk-Advance Group
Sognevej 25
DK-2605 Brøndby
Tel.: (+45) 4323 8100
E-mail: mail.com@nilfisk-advance.com

SALES COMPANIES

AUSTRALIA

Nilfisk-Advance
48 Egerton St.
P.O. Box 6046
Silverwater, N.S.W. 2128
Website: www.nilfisk.com.au

AUSTRIA

Nilfisk-Advance GmbH
Metzgerstrasse 68
5101 Bergheim bei Salzburg
Website: www.nilfisk.at

BELGIUM

Nilfisk-Advance n.v.-s.a.
Riverside Business Park
Boulevard Internationalelaan 55
Bâtiment C3/C4 Gebouw
Bruxelles 1070
Website: www.nilfisk.com

CHILE

Nilfisk-Advance de Chile
San Alfonso 1462
Santiago
Website: www.nilfisk.com

CHINA

Nilfisk-Advance (Suzhou)
Building 18, Suchun Industrial Estate
Suzhou Industrial Park
215021 Suzhou
Website: www.nilfisk-cs.com

CZECH REPUBLIC

Nilfisk-Advance
VGP Park Horní Počernice
Do Čertous 1/2658
193 00 Praha 9
Website: www.nilfisk.com

DENMARK

Nilfisk-Advance Denmark A/S
Sognevej 25
2605 Brøndby
Tel.: (+45) 4323 4050
E-mail: kundeservice.dk@nilfisk.com

FINLAND

Nilfisk-Advance Oy Ab
Koskelontie 23 E
02920 Espoo
Website: www.nilfisk.fi

FRANCE

Nilfisk-Advance
26 Avenue de la Baltique
Villebon sur Yvette
91978 Courtabouef Cedex
Website: www.nilfisk.fr

GERMANY

Nilfisk-Advance
Guido-Oberdorfer-Straße 2-10
89287 Bellenberg
Website: www.nilfisk.de

GREECE

Nilfisk-Advance A.E.
Αναπαύσεως 29
Κορωπί T.K. 194 00
Website: www.nilfisk.gr

HOLLAND

Nilfisk-Advance
Versterkerstraat 5
1322 AN Almere
Website: www.nilfisk.nl

HUNGARY

Nilfisk-Advance Kereskedelmi Kft.
II. Rákóczi Ferenc út 10
2310 Szigetszentmiklos-Lakihegy
Website: www.nilfisk.hu

INDIA

Nilfisk-Advance India Limited
Pramukh Plaza, 'B' Wing, 4th floor, Unit No. 403
Cardinal Gracious Road, Chakala
Andheri (East) Mumbai 400 099
Website: www.nilfisk.com

IRELAND

Nilfisk-Advance
1 Stokes Place
St. Stephen's Green
Dublin 2
Website: www.nilfisk.com

ITALY

Nilfisk-Advance SpA
Strada Comunale della Braglia, 18
26862 Guardamiglio (LO)
Website: www.nilfisk.it

JAPAN

Nilfisk-Advance Inc.
1-6-6 Kita-shinyokohama, Kouhoku-ku
Yokohama, 223-0059
Website: www.nilfisk.com

MALAYSIA

Nilfisk-Advance Sdn Bhd
Sd 14, Jalan KIP 11
Taman Perindustrian KIP
Sri Damansara
52200 Kuala Lumpur
Website: www.nilfisk.com

MEXICO

Nilfisk-Advance de Mexico, S. de R.L. de C.V.
Agustín M. Chavez No. 1, PB oficina 004
Col. Centro de Ciudad Santa Fe
01210 Mexico, D.F.
Website: www.nilfisk.com

NEW ZEALAND

Nilfisk-Advance
Danish House
6 Rockridge Avenue
Penrose, Auckland 1135
Website: www.nilfisk.com

NORWAY

Nilfisk-Advance AS
Bjørnerudveien 24
1266 Oslo
Tel.: (+47) 22 75 17 70
E-mail: info.no@nilfisk.com

POLAND

Nilfisk-Advance Sp. Z.O.O.
ul. 3 Maja 8
05-800 Pruszków
Website: www.nilfisk.pl

PORTUGAL

Nilfisk-Advance
Sintra Business Park
Zona Industrial Da Abrunheira
Edificio 1, 1º A
P2710-089 Sintra
Website: www.nilfisk.pt

RUSSIA

Нилфиск-Эдванс
127015 Москва
Вятская ул. 27, стр. 7
Россия
Website: www.nilfisk.ru

SOUTH AFRICA

WAP South Africa
12 Newton Street
Spartan 1630
Website: www.nilfisk.com

SOUTH KOREA

Nilfisk-Advance Korea
3F Duksoo B/D, 317-15
Sungsoo-Dong 2Ga, Sungdong-Gu
Seoul
Website: www.nilfisk.com

SPAIN

Nilfisk-Advance S.A.
Torre d'Ara, Planta 9
08302 Mataró
Barcelona
Website: www.nilfisk.es

SWEDEN

Nilfisk-Advance AB
Taljegårdsgatan 4
431 53 Mölndal
Website: www.nilfisk-alto.se

SWITZERLAND

Nilfisk-Advance
Ringstrasse 19
Kircheberg/Industri Stelzi
9500 Wil
Website: www.nilfisk-alto.ch

TAIWAN

Nilfisk-Advance Taiwan Branch
1F, No. 193, sec. 2, Xing Long Rd.
Taipei
Tel.: (+88) 6227 002 268
Website: www.nilfisk-alto.tw

THAILAND

Nilfisk-Advance Co. Ltd.
89 Soi Chokeychai-Ruammitr
Viphavadee-Rangsit Road
Ladyao, Jatuchak, Bangkok 10900
Website: www.nilfisk-thailand.com

TURKEY

Nilfisk-Advance A.S.
Serifali Mh. Bayraktar Bulv. Sehit Sk. No:7
Ümraniye
Istanbul
Website: www.nilfisk.com

UNITED KINGDOM

Nilfisk (A Division of Nilfisk-Advance Ltd.)
Bowerbank Way
Gilwilly Industrial Estate, Penrith
Cumbria CA11 9BQ
Tel: 01768 868995
Website: www.nilfisk.co.uk

UNITED ARAB EMIRATES

Nilfisk-Advance Middle East Branch
SAIF-Zone
P.O. Box 122298
Sharjah
Website: www.nilfisk.com

VIETNAM

Nilfisk-Advance Representative Office
No. 51 Doc Ngu Str.
Ba Dinh Dist.
Hanoi
Website: www.nilfisk.com