

RESET

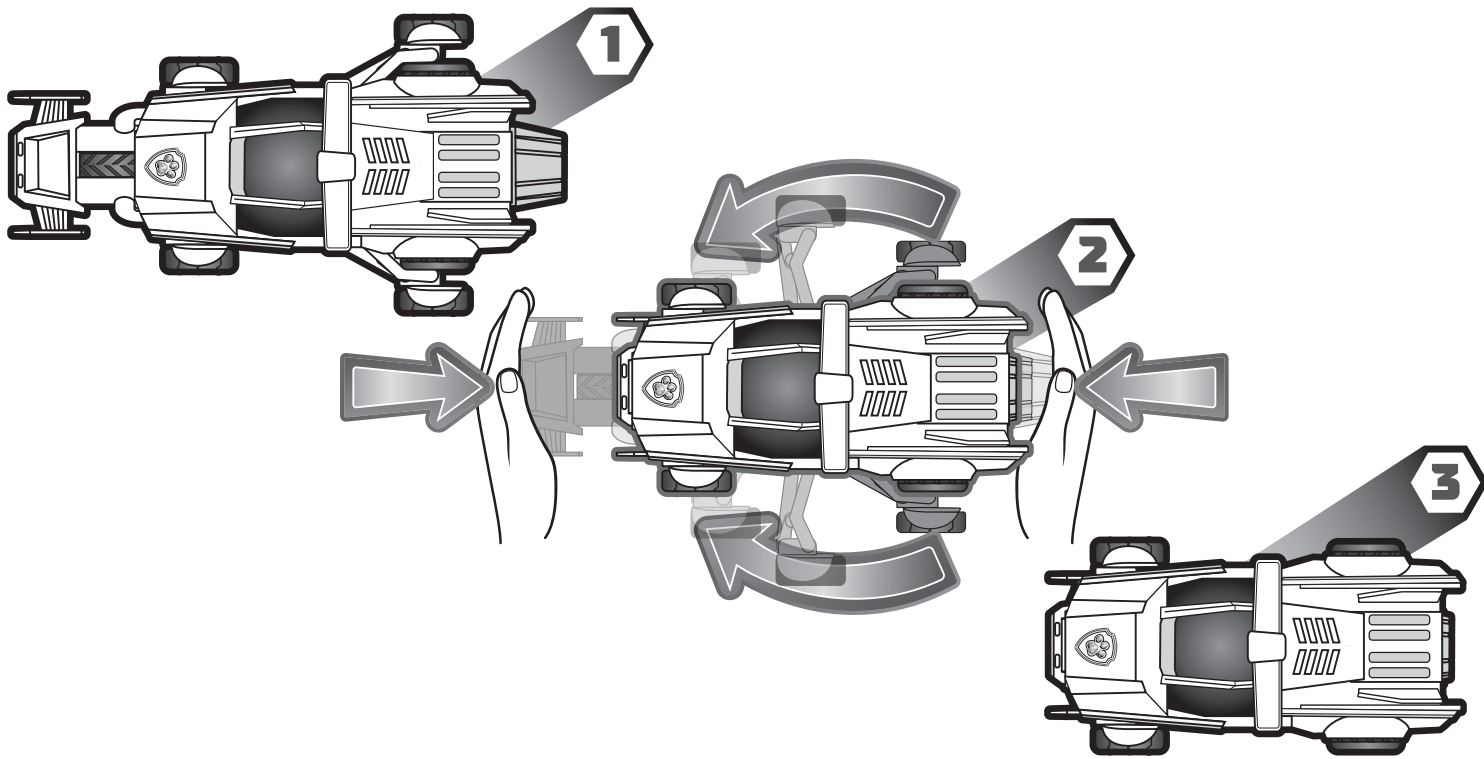

INSTRUCTION GUIDE

3+



CONTENTS

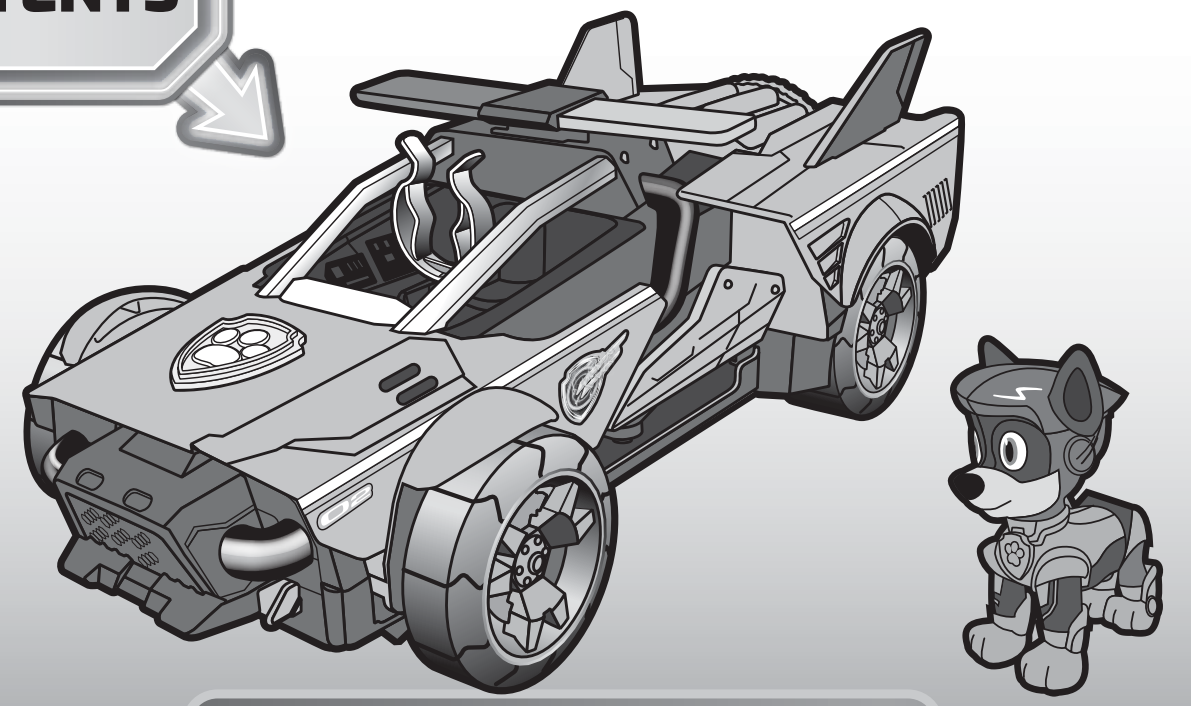

FCC STATEMENT: This device complies with Part 15 of the FCC rules. Operation is subject to the following two conditions: (1) This device may not cause harmful interference, and (2) This device must accept any interference received, including interference that may cause undesired operation. This equipment has been tested and found to comply with the limits for Class B digital devices pursuant to Part 15 of the FCC rules. These limits are designed to provide reasonable protection against harmful interference to radio communications. This equipment generates, uses and can radiate radio frequency energy and, if not installed and used in accordance with the instruction, may cause harmful interference to radio communication. However, there is no guarantee that interference will not occur in a particular installation. If this toy does cause interference to radio or television reception (you can check this by turning the toy off and on while listening for the interference), one or more of the following measures may be useful:

- Reorient or relocate the receiving antenna
- Increase the separation between the toy and the radio or the TV
- Consult the dealer or an experienced TV-radio technician for help.

NOTE: Changes, adjustments or modifications to this unit, including but not limited to, replacement of any transmitter component (crystal, semiconductor, etc) could result in a violation of FCC rules under part 15 and/or 95 and must be expressly approved by Spin Master Ltd or they could void the user's authority to operate the equipment. Spin Master Inc., PMB #10053, 300 International Drive, Suite 100, Williamsville, NY 14221. To contact the responsible party please visit fcc.spinmaster.com

CAN ICES-3(B) / NMB-3(B)



Requires 3 x 1.5 V AAA (LR03) batteries (included). Batteries or battery packs must be removed for recycling and proper disposal. When this product has reached the end of its useful life, it should not be disposed of with other household waste. EU legislation for Electrical and Electronic Equipment and Batteries, requires these to be separately collected so that they can be treated using the best available recovery and recycling techniques. This will minimize the impact on the environment and human health from soil and water contamination by any hazardous substances, decrease the resources required to make new products and avoid using up landfill space. Please do your part by keeping this product out of the municipal waste stream! The "wheelie bin" symbol means that it should be collected as "waste electrical and electronic equipment". You can return an old product to your retailer when you buy a similar new one. For other options, please contact your local council.

Batteries included are for in-store demonstration and should be replaced to improve performance.

Retain this information, addresses and phone numbers for future reference.

Spin Master Ltd., 225 King Street West, Toronto ON M5V 3M2 Canada
 Spin Master Inc., PMB #10053, 300 International Drive, Suite 100, Williamsville, NY 14221
 Spin Master International B.V., Kingsfordweg 151, 1043 GR Amsterdam, NL
 Spin Master Australia Pty Ltd, Suite 101, Level 1, 18-24 Chandos Street, St Leonards, NSW 2065; ☎ 1800 316 982
 Spin Master Toys UK Ltd. Boston House, Boston Drive, Bourne End, Buckinghamshire, SL8 5YS, UK



CHASE

MIGHTY TRANSFORMING CRUISER™

3xAAA (LR03)
1.5V / 1.5V
INCLUDED



NORTH AMERICA - 1-800-622-8339
customercare@spinmaster.com
UK - 0800 206 1191, serviceuk@spinmaster.com
IRELAND - 1800 992 249
AUSTRALIA - 1800 316 982, customercare@spinmaster.com

WWW.SPINMASTER.COM

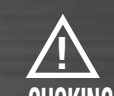

WARNING:

CHOKING HAZARD - Small parts. Not for children under 3 years.

Caution - Do not shine bright lights into eyes. Direct viewing of bright lights may impair vision.



MADE IN CHINA
 T17732_0007_20141196_GEN_IS_R2

BATTERY REMOVAL AND INSTALLATION INSTRUCTIONS

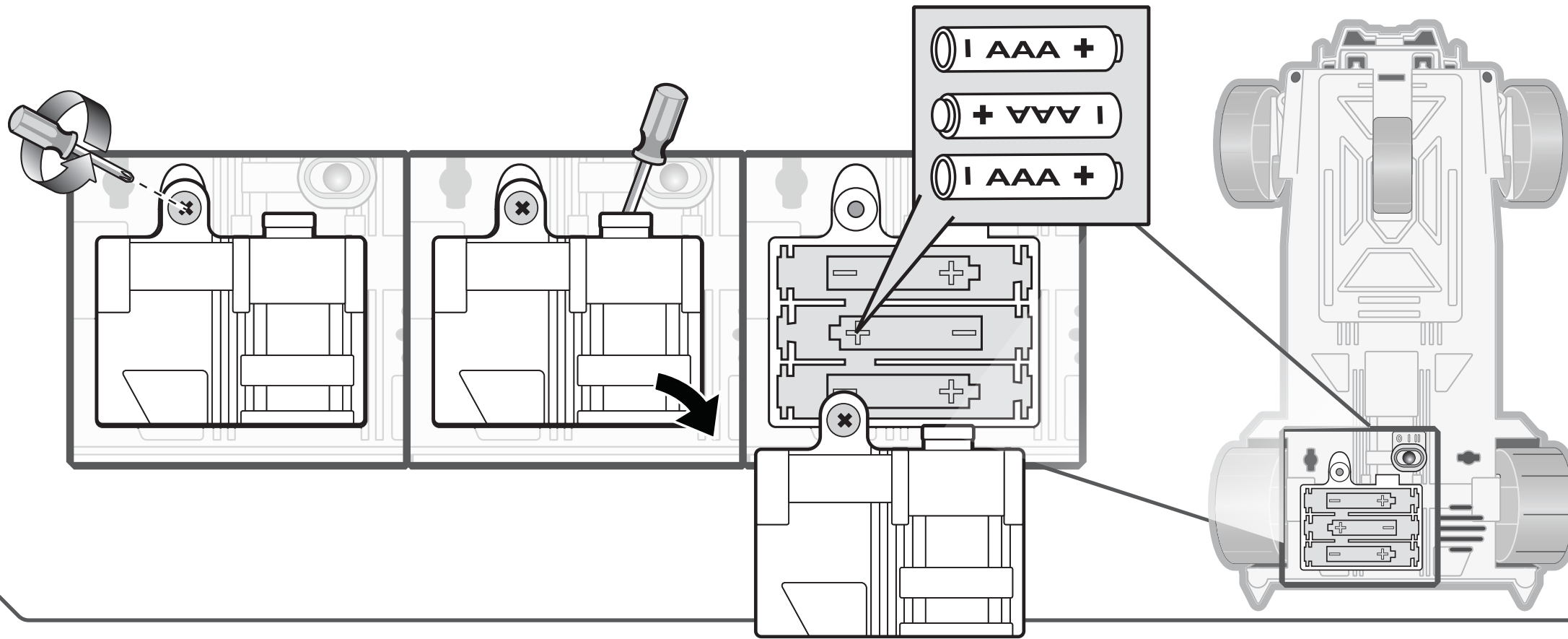

HOW TO INSTALL BATTERIES: 1. Open the battery door with a screwdriver. 2. If used batteries are present, remove these batteries from the unit by pulling up on one end of each battery. **DO NOT** remove or install batteries using sharp or metal tools. 3. Install new batteries as shown in the polarity diagram (+/-) inside the battery compartment. 4. Replace battery door securely. 5. Check your local laws and regulations for correct recycling and/or battery disposal.

BATTERY SAFETY INFORMATION: Batteries are small objects. Replacement of batteries must be done by adults. Follow the polarity (+/-) diagram in the battery compartment. Promptly remove dead batteries from the toy. Dispose of used batteries properly. Remove batteries for prolonged storage. Only batteries of the same or equivalent type as recommended are to be used. **DO NOT** incinerate used batteries. **DO NOT** dispose of batteries in fire, as batteries may explode or leak. **DO NOT** mix old and new batteries or types of batteries (i.e. alkaline/standard/rechargeable). Using rechargeable batteries is not recommended due to possible reduced performance. Rechargeable batteries are only to be charged under adult supervision. Replaceable-rechargeable batteries are to be removed from the toy before being charged. **DO NOT** recharge non-rechargeable batteries. **DO NOT** short-circuit the supply terminals.

LET'S PLAY

