

Technical data

Column Stage	3
Max. Weight Capacity	125KG
Height Range	630-1280mm
Width Range	1100-1900mm

Accessory list

Attention: The drawings below are for guidance only and they may differ slightly from the product and fittings received. Please contact our customer service department should you have any queries.

No.	Image	Spec	Qty
A		M6	4
B		M6	4
C		M6	8
D		M6	12
E		St4.2	16
F		Allen Key 4x4mm	1

Component list

①		2	②		2
③		1	④		1
⑤		2	⑥		1
⑦		1			

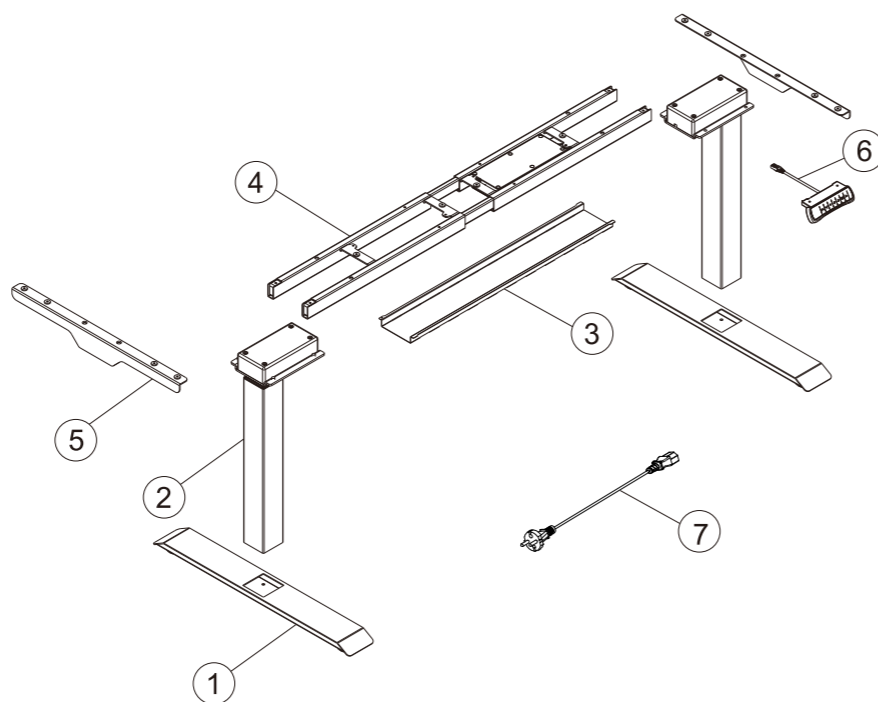

STEP 1

Install the Side Brackets

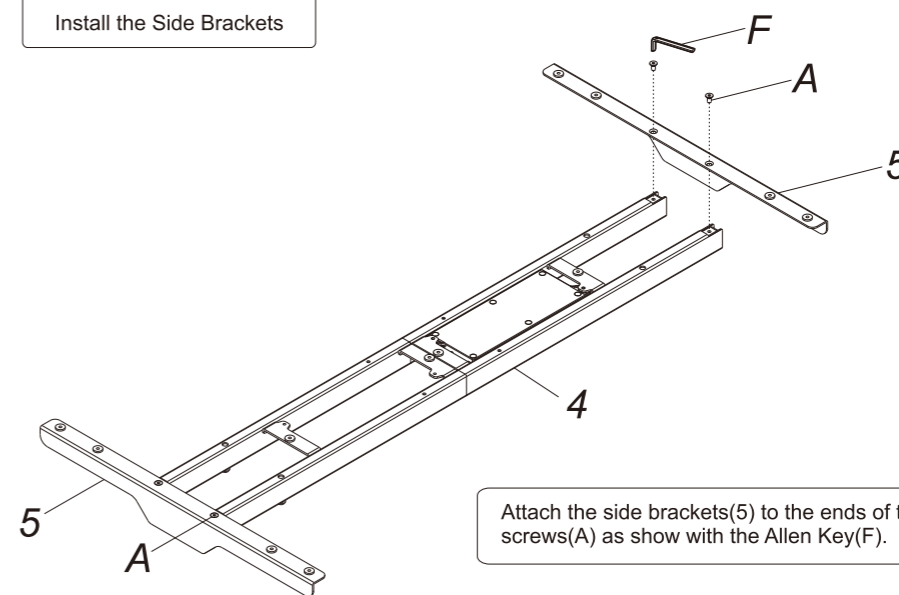

Attach the side brackets(5) to the ends of the supporting beam (4) using screws(A) as show with the Allen Key(F).

STEP 2

Install the Lifting Columns

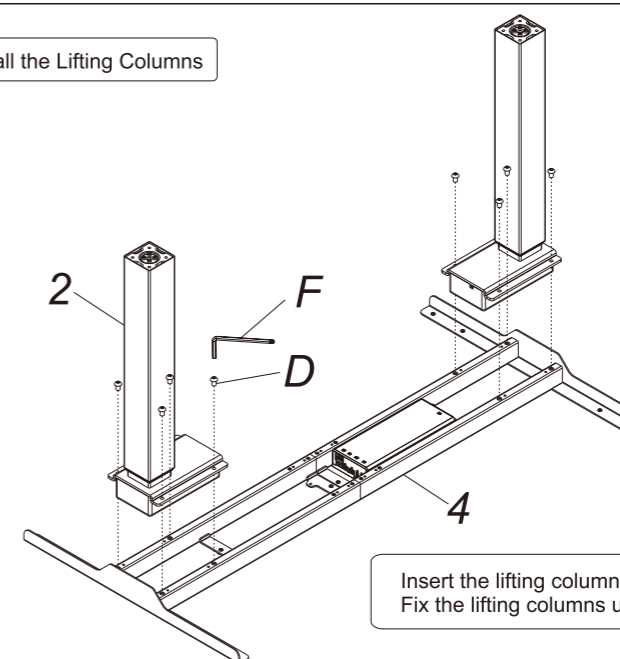

Insert the lifting columns (2) into the ends of the supporting beam(4). Fix the lifting columns using screws(D) with the Allen Key(F).

STEP 3

Install the Feet

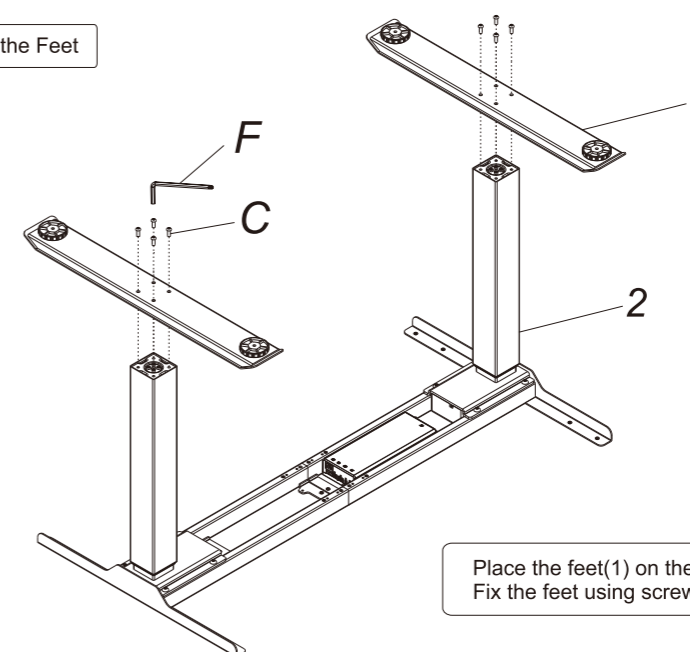

Place the feet(1) on the bottom of the lifting column(2). Fix the feet using screws(C) with Allen Key(F).

STEP 4

Install the Tabletop

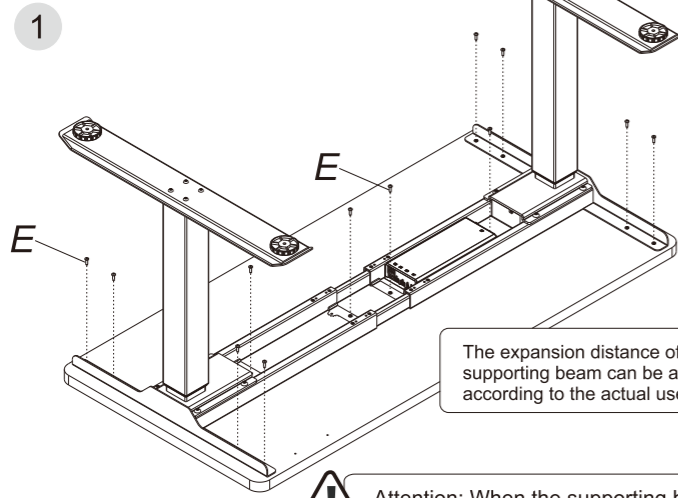
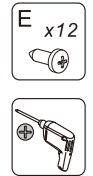

The expansion distance of the supporting beam can be adjusted according to the actual use.

Attention: When the supporting beam is greater than 1720mm, the installation method is as follows: Method 2 in Step 6.

2

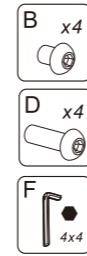
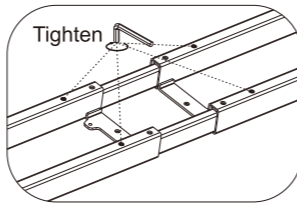
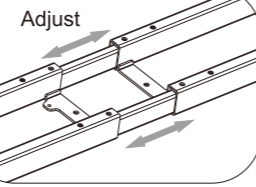
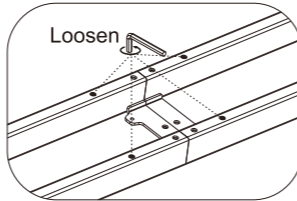

Method 2

Install the cable management tray as Method 1, Step 6.

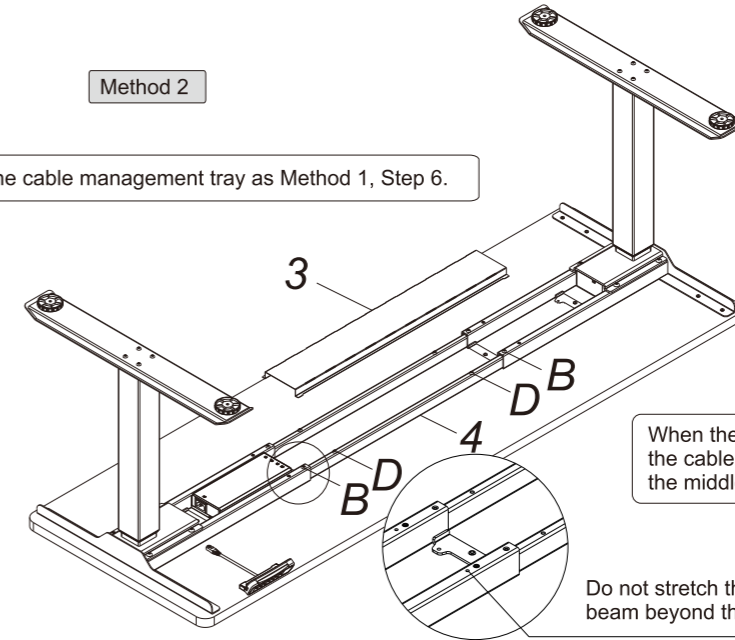

When the supporting beam stretches over 1720 mm, the cable management tray needs to be mounted on the middle of the supporting beam.

Do not stretch the support beam beyond this hole

STEP 5

Install the Control Panel

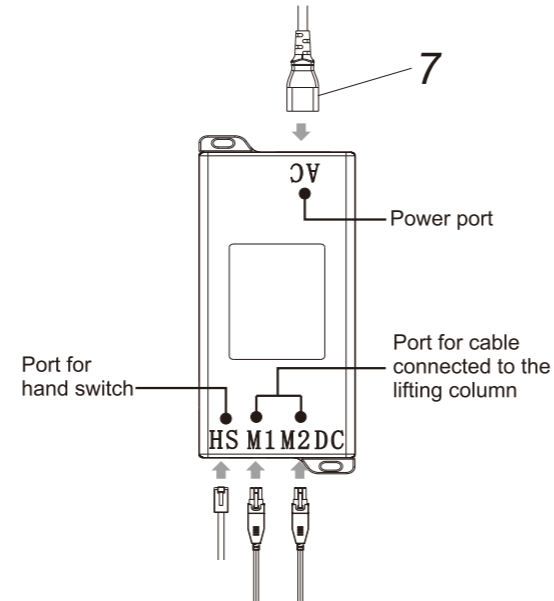
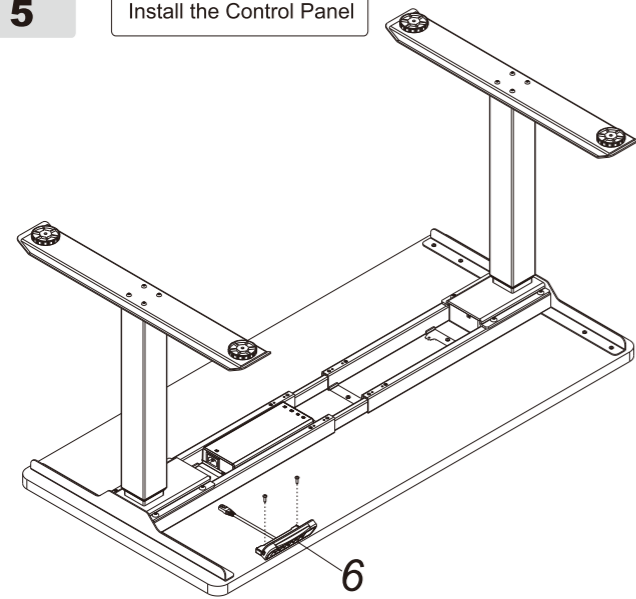

Common fault treatment

The following tips will help you detected and eliminate the common fault and error. If the fault you met is not listed below, please contact with your supplier. Only the manufacturer and professionals are capable for investigating and correcting those fault and error.

Fault phenomenon	Method
No response while long pressing down arrow after connected with a power supply	1. Check if all the cables be connected well
	2. Contact your supplier or dealer
No response while pressing up arrow/ down arrow after connected with a power supply	1. Check if all the cables be connected well
	2. Contact your supplier or dealer
Rising in a low speed	1. Check if overloaded, max loading: 125kg;
	2. Contact your supplier or dealer
The motor not move as instructed	1. Contact your supplier or dealer
Go down but not go up	1. Reposition
	2. Contact your supplier or dealer
Downward sliding	1. Check if overloaded, max loading: 125kg;
	2. Contact your supplier or dealer
Frequently Reposition	1. Check if overloaded, max loading: 125kg;
	2. Contact your supplier or dealer
Overwork (Duty cycle: Max 2min on/18min OFF)	1. Restart after suspend for 18mins while connecting with power;
	2. Contact your supplier or dealer;
Not enough up&down height	1. Press "M" and "3" together for 3 seconds or more, after hearing continuous beeping for twice, it will restore factory settings
	2. Contact your supplier or dealer

Attention

- Power supply: AC100V-240V,50/60Hz
- Service Environment: 0-40°C
- Unplug the power plug before cleaning, wipe the dust on surface with slight wet dishcloth when cleaning, be careful not to let the drops into the internal parts, not loose the connector.
- The electric box contains electronic components, metals, plastics, wires etc., so dispose of it in accordance with each country's environmental legislation, not the general household waste.
- Check carefully to ensure correct and complete assembly before using.
- Be familiar with all functions and program settings of the product before first use.
- Children are forbidden to play on the product because of unforeseen action when playing, so any dangerous consequences caused by this improper action will not be on.
- Slight noise caused by the V-ribbed belt or brake system due to structure will not have any effect on the use of the equipment.
- Corrosive or abrasive materials are forbidden to clean the equipment. Must ensure that the cleaner used will not pollute the environment.
- This appliance can be used by children aged from 8 years and above and persons with reduced physical, sensory or mental capabilities or lack of experience and knowledge if they have been given supervision or instruction concerning use of the appliance in a safe way and understand the hazards involved. Children shall not play with the appliance.
- Cleaning and user maintenance shall not be made by children without supervision.
- If the supply cord is damaged, it must be replaced by the manufacturer, its service agent or a similarly qualified person in order to avoid a hazard.
- Please make sure there is no hazard sources in your operating environment. e.g., do not litter the tools around. Always be careful to treat the packaging materials in order to avoid any possible danger, e.g. plastic bag may lead to choking hazard to children.
- Keep the original package of the equipment if necessary in case of the future use in transportation.

STEP 6

Install the Cable Management Tray

Method 1

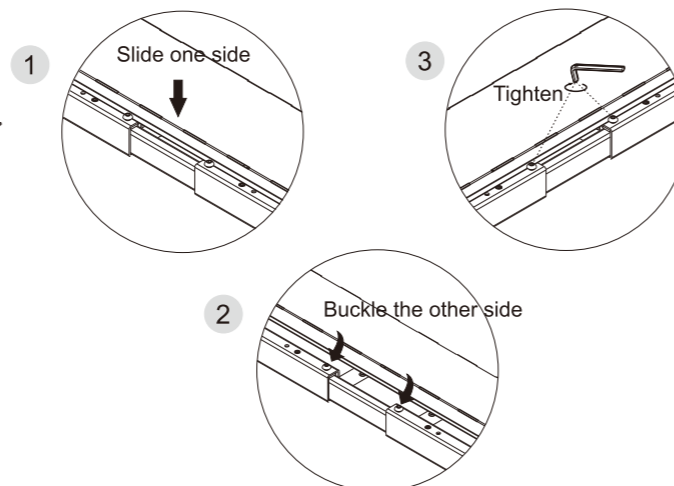
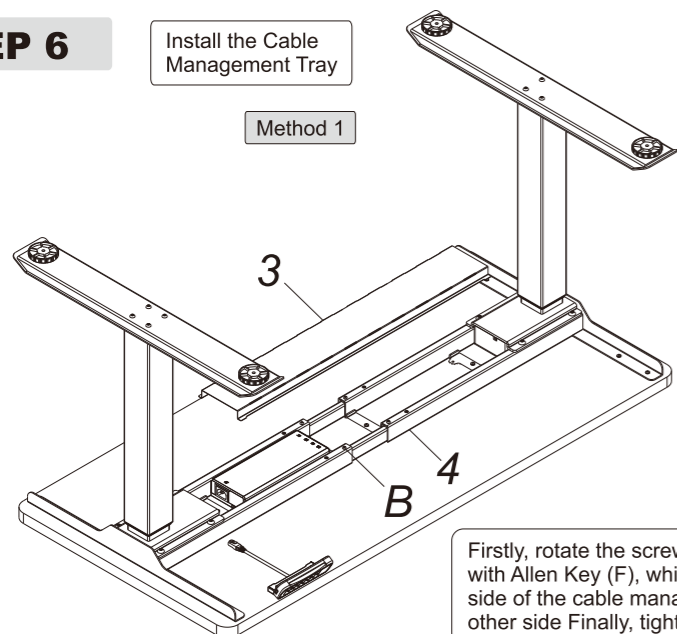

Firstly, rotate the screws (B) incompletely into the supporting beam (4) with Allen Key (F), which means do not tighten them. Next, slide one side of the cable management tray (3) into the screws (B), then the other side. Finally, tighten the screws (B) with Allen Key (F).

Waste disposal



This marking indicates that this product should not be disposed with other household wastes. To prevent possible harm to the environment or human health from uncontrolled waste disposal, recycle it responsibly to promote the sustainable reuse of material resources. To return your used device, please use the return and collection systems or contact the retailer where the product was purchased. They can take this product for environmental safe recycling.