



# NURATRUE User Manual



model: T00B  
Power: 5V, 0.2A  
Wireless frequency band: 2400-2483.5 MHz



# Contents

<b>NURATRUE safety information</b>	<b>3</b>
<b>Getting started</b>	<b>5</b>
What's in the box	5
Fitting your NURATRUE	6
Turning your NURATRUE on/off	7
Downloading the Nura app	7
Connecting your NURATRUE with Bluetooth®	7
Swapping between Bluetooth® devices	7
Personalising your NURATRUE	8
Updating your NURATRUE	8
<b>Your NURATRUE</b>	<b>9</b>
Charging your NURATRUE	9
Checking your NURATRUE battery	9
Using the Touch Buttons	9
Making and receiving voice calls with your NURATRUE	10
Connecting your NURATRUE to other products	10
Computers	10
TVs	11
Changing your NURATRUE Ear Tips	11
Cleaning the NURATRUE	11
<b>The Nura app</b>	<b>12</b>
Nura app features	12
Choosing your level Immersion	12
Customising the NURATRUE Touch Buttons	12
Adjusting your Active Noise Cancellation (ANC)/ Social Mode	12
Changing the NURATRUE voice language	12
Switching, adding and deleting hearing profiles	14
<b>Troubleshooting</b>	<b>15</b>
Resetting your NURATRUE	15
Charging troubleshooting	15
Personalisation troubleshooting	15
Nura App troubleshooting	16
Bluetooth troubleshooting	16
Voice calls troubleshooting	16
Sound Quality troubleshooting	17
Touch Buttons troubleshooting	17
<b>Need more help?</b>	<b>17</b>
<b>Warranty</b>	<b>17</b>
<b>Compliance</b>	<b>18</b>



# NURATRUE safety information



**Read this manual before using the NURATRUE for the first time.  
Keep this manual handy for future reference.**

The NURATRUE has been designed and tested for safety and comfort, but please note: exposure to any noise of 85 Decibels (dB) or above (approximately the same volume as a food blender) can cause gradual hearing loss. Due to the clarity and noise cancelling of the NURATRUE, you won't need to listen to your music as loudly as with many conventional headphones.

Monitor your use. Hearing loss is a function of loudness versus time — the louder the volume, the less time you can be exposed to it. The quieter the volume, the longer you can listen. For example, 8 hours at 85 dB causes as much damage as 4 hours at 88 dB, 2 hours at 91 dB, or just 15 minutes at 100 dB.

Only use the NURATRUE with the volume set at a comfortable, moderate level.

Do not listen to music at a high volume for any extended period.

Be aware that reminders or warning sounds, i.e. alarms, message tones and incoming calls, might vary while using the NURATRUE.

If you experience a warming sensation or loss of hearing, remove the NURATRUE from your head immediately and contact Nura support.

If the NURATRUE emits a loud or unusual noise, stop using it and contact Nura support immediately.

Due to noise-cancelling technology, do not use the NURATRUE at any time when an inability to hear may present a danger to yourself or others. For example, while driving, riding a bicycle, in a construction site, or in or near traffic.

If you're using the NURATRUE for phone calls while driving, then use caution and follow applicable laws regarding mobile phone and headphone use. Some jurisdictions impose specific limitations such as using a single earpiece while driving.

Use only certified Nura cables to charge the NURATRUE.

Charging the NURATRUE should be done only by following the instructions in this user manual.

Do not make unauthorised alterations to this product. Any attempt to do so will void the warranty.

CAUTION the battery shall not be exposed to excessive heat such as sunshine, or the like.

## DISPOSE OF USED BATTERIES ACCORDING TO THE INSTRUCTIONS

Disposal of a battery into fire or a hot oven, or mechanically crushing or cutting of a battery, can result in an explosion.

Leaving a battery in an extremely high temperature surrounding environment can result in an explosion or the leakage of flammable liquid or gas.

A battery subjected to extremely low air pressure may result in an explosion or the leakage of flammable liquid or gas.



**Contains small parts which may be a choking hazard. Not suitable for children under age 3.**



**This product contains magnetic material. Consult your physician on whether this might affect your implantable medical device.**



**Removal of the rechargeable lithium-ion battery in this product should be conducted only by a qualified professional.**



# Getting started

## Charging Case

- 1 LED charging light
- 2 USB-C charging port

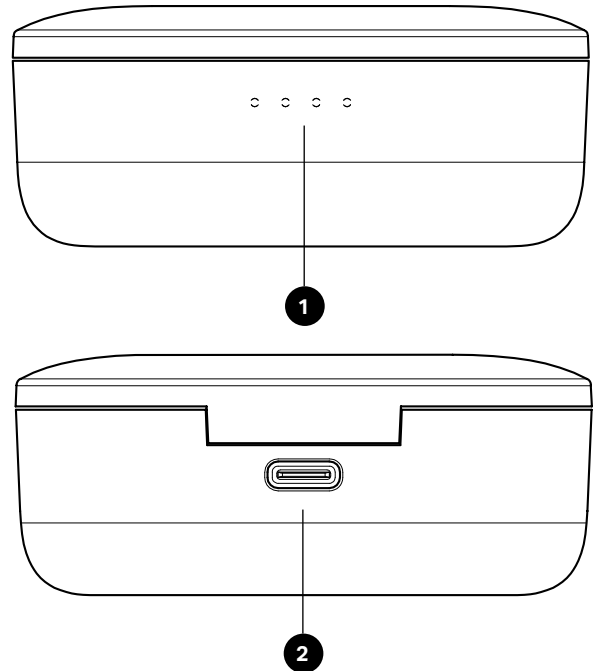

## NURATRUE

- 3 Voice Call Microphones
- 4 Removable ear tip
- 5 Removable wing attachment
- 6 Touch Buttons

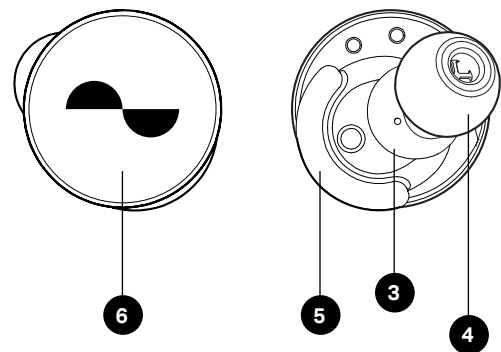

## What's in the Box

Your NURATRUE will come with:

- 1. NURATRUE
- 2. USB-A to USB-C charging cable
- 3. Charging Case
- 4. 4 x Multi-Sized silicone earbuds
- 5. 1 x Foam tips
- 6. 2 x Wing attachments



## Fitting your NURATRUE

### Put your NURATRUE on

1. Left and Right - Hold the ear bud marked L in your left hand, and the ear bud marked R in your right hand
2. Adjust the fit - Insert the earbuds into your ears and slightly twist backwards to find the right fit. Your NURATRUE should feel secure and comfortable.
3. To ensure your NURATRUE fits comfortably, try the different sized ear tips and wing attachments to find what works best for you.

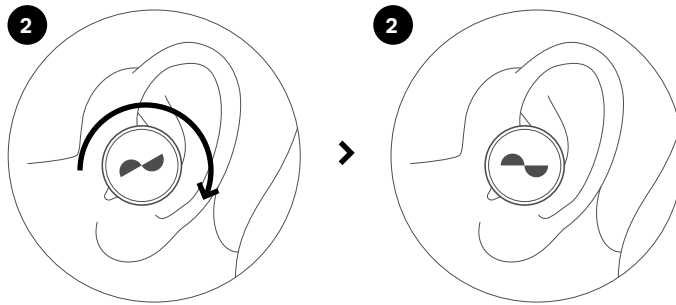

### If you're using foam tips, you'll need to:

1. Compress the foam tip by rolling your fingers.
2. Pull your ear back. Insert the entire foam tip into your ear and slightly twist backwards.
3. Hold in place for 15-30 seconds for foam to expand and create seal.

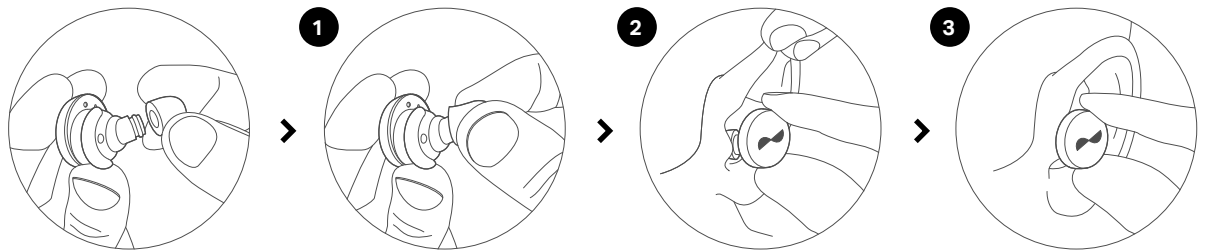



## Turning Your NURATRUE on/off

Your NURATRUE turns on and off automatically when you put it in your ears.

**To Power On:** Remove your NURATRUE from the charging case.

**To Power Off:** Place your NURATRUE into the charging case.

**Power reserve:** By default, your NURATRUE will pause playback if one earbud has been removed from your ears and resume when placed back on. Your NURATRUE will automatically power off after 60 seconds if both earbuds have been removed from your ears. You can customise the power reserve functionality within the Nura app.

## Downloading the Nura App

To set up your NURATRUE, you'll need to personalise it via the Nura app.

You can download the Nura app from:

- iOS — the App Store
- Android — Google Play

### Nura app system requirements:

- iOS — iOS 9.3+ and Bluetooth® 4
- Android — Android 5.0+ and Bluetooth® 4

## Connecting Your NURATRUE With Bluetooth®

You'll need to connect your NURATRUE to your mobile device via Bluetooth to access the Nura app and personalise your NURATRUE.

To connect your NURATRUE with Bluetooth:

1. To enter pairing mode, tap and hold down both touch buttons on each side.
2. On your mobile device go to **Settings > Bluetooth**
3. Select **NURATRUE XXX**. XXX is the NURATRUE unique pairing number.

## Swapping Between Bluetooth® Devices

Your NURATRUE automatically enters discoverable mode for two minutes when you enter pairing mode. To enter pairing mode, tap and hold down both touch buttons on each side.

When your NURATRUE is in discoverable mode, select NURATRUE XXX in the Bluetooth settings of any device you'd like to switch to.

A voice prompt will announce "Bluetooth device changed."

You have now swapped your connection.



## Personalising Your NURATRUE

Before you can start using your NURATRUE, you will need to personalise it. When you personalise, your NURATRUE learns how you hear.

### Before personalising your NURATRUE:

1. Download the Nura app.
2. In the Nura app, tap **Create an account** and enter your details.
3. If you already have a Nura account, then tap **Log in** instead.
4. Select **NURATRUE**.
5. Pair your NURATRUE with your mobile device.

### Personalising your NURATRUE:

1. In the Nura app, tap **Begin** to begin personalisation.
2. Adjust your NURATRUE earbuds by rotating them back and forth until you see two constant ticks on the Nura app screen. Once you have a good fit, personalisation starts and takes about a minute.
3. Tap **Personalised** to hear music with your hearing profile applied.
4. Tap the Social Mode button to hear your surroundings.
5. Customise your NURATRUE touch buttons. You can also do this later via Settings.

Your NURATRUE is now personalised with your unique hearing profile.

## Updating Your NURATRUE

In order to access the latest and greatest features for your NURATRUE make sure you update:

### Your Nura App

To update the Nura App, open the App Store (for iOS devices) or Google Play (for Android devices) to check for available updates.

### Your NURATRUE

Every now and then, we'll add significant improvements to the NURATRUE with a firmware upgrade. These will be either automatically applied to your device or you may need to perform the below.

To update your NURATRUE firmware:

1. Open the Nura app.
2. A message will appear that an update is available, tap **Start** update,  
or, Tap **Menu > Device Settings > Software update > Start update**
3. Your upgrade will begin.

Feel free to take off your NURATRUE, but keep it close to your phone with the screen turned on.





# Your NURATRUE

This section contains everything you need to know about using your NURATRUE.

## Charging the NURATRUE and Case

The NURATRUE battery provides 6+ hours of wireless use, and up to 24 hours of use when using the charging case.

- **To charge your NURATRUE**, place them in the case and close the lid. Your NURATRUE shuts down and charges when placed inside the case. Your case holds multiple full charges for your NURATRUE so you can charge on the move. To keep your NURATRUE charged, put them in the case when you're not using them. The NURATRUE battery takes approximately two hours to fully charge.
- **To charge your case**, connect the case to the included USB-C charging cable and plug it into a computer or wall adapter. The LED lights will pulse when charging. Once fully charged, the LED lights will turn solid. The case takes approximately two hours to fully charge.

## Checking the NURATRUE Battery

While connected to your NURATRUE, you can check the battery indicator in the top-right corner of the Nura app.

A voice prompt will announce "battery low" when your NURATRUE needs charging.

A voice prompt will announce "battery critical" when your NURATRUE is about to power off.

## Checking the Case Battery

The case has 4 LEDs which indicate the level of charge of the case battery when opened for 4 seconds.

## Using the NURATRUE Touch Buttons

The NURATRUE has touch buttons on each side that you can tap to perform useful functions.

### You can customise your touch buttons in the Nura app:

1. Open the Nura app with your NURATRUE connected via Bluetooth to your device.
2. Tap on the Menu icon at the top left (☰).
3. Tap on **Device settings > Configure Touch Buttons**.
4. Choose the Tap controls you wish to adjust



### Tap/Double Tap

- Play/Pause
- Play/Pause/Answer Call/Hang-up Call
- Play/Pause/Answer Call
- Next Track
- Previous Track
- Toggle ANC/Social Mode
- Toggle Immersion Mode
- Volume up
- Volume down
- Voice Assistant

### Tap and hold

Tap and hold both touch buttons to enter pairing mode.

## Making and Receiving Voice Calls With Your NURATRUE

The NURATRUE includes highly sensitive microphones for enhanced voice call quality.

When your NURATRUE is connected via Bluetooth, you can answer voice calls:

- Directly on your phone.
- By using the NURATRUE Touch buttons, if you have customised the functionality within the Nura app.

## Connecting Your NURATRUE to Other Products

You can connect your NURATRUE to other products using Bluetooth.

### Computers

#### Mac

- Tap and hold down both touch buttons on each side of your NURATRUE to enter pairing mode.
- On your Mac, choose Apple menu > System Preferences, then click Bluetooth.
- Select NURATRUE XXX on the device list. XXX is the NURATRUE unique pairing number.

Your NURATRUE is now connected.

#### PC

1. Tap and hold down both touch buttons on each side of your NURATRUE to enter pairing mode.
2. Click the Bluetooth icon on your computer's taskbar.



3. From Bluetooth & other devices, click Add Bluetooth or other device.
4. Select NURATRUE XXX. XXX is the NURATRUE unique pairing number.

## TVs

Audio configurations on TVs vary. Check your TV's connectivity is compatible with NURATRUE connectivity.

## Changing the NURATRUE Ear Tips

The NURATRUE comes with five ear tip sizes. Try all the ear tip sizes to find the ones that best fit your ears. You'll know you have a good seal if the sound around you quietens when you put on your NURATRUE.

To remove an ear tip gently pull with your fingers at the base of the ear tip, where it is attached to the NURATRUE.

To attach an ear tip, push the new ear tip all the way down over the opening and onto the NURATRUE.

## Changing the NURATRUE Wing Attachments

The NURATRUE comes with two wing sizes/types.

Try both wing sizes to find the ones that best fit your ears. The NURATRUE can also be used without the wings.

To change the NURATRUE wings:

1. Gently pull the wing to remove.
2. Push the new wing onto the NURATRUE.
3. Check the new wing is pushed on all the way.
4. To check the wings are fitted correctly, the hole on the wing should be aligned with the notch on your NURATRUE. The NURATRUE should fit comfortably in your ear and create a seal. You will know you have a good seal if the sound around you quietens.

## Cleaning the NURATRUE

Your NURATRUE needs cleaning from time to time.

Please note: never use alcohol, cleaning solvents, or strong detergents when cleaning the NURATRUE.

**To clean the NURATRUE ear tips:**

1. Remove the ear tips, and wash them with water and a mild detergent.
2. Rinse and dry the ear tips and set aside.
3. Reattach the ear tips.
4. Wipe the NURATRUE with a soft, damp cloth.



# The Nura app

Read on for everything that you need to know about the Nura app —

With the Nura app, you can adjust the level of Immersion, change or add Hearing Profiles, check battery status, enable/disable ANC and Social Mode, and more.

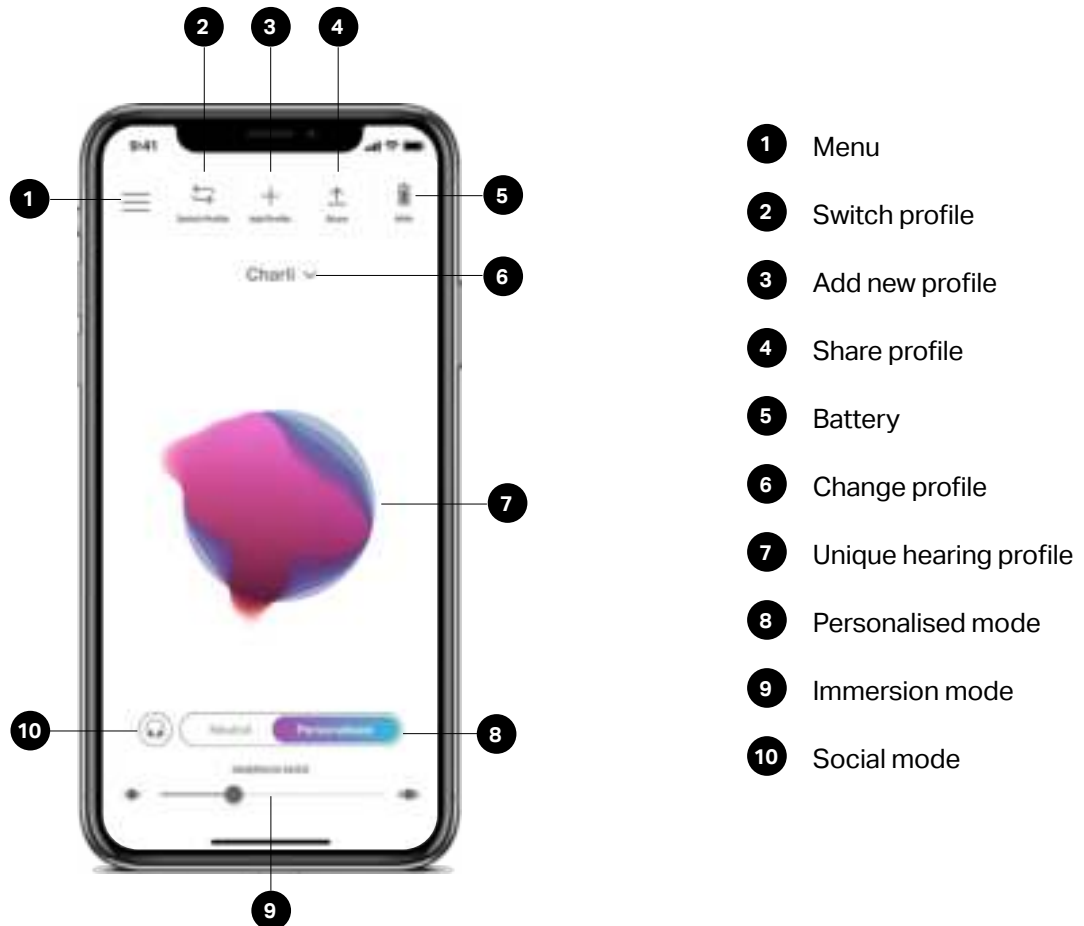



## Choosing the Level of Immersion

1. Open the Nura app.
2. Use the Immersion slider to choose your preferred level of bass.

Please note: always set your Immersion to a comfortable, moderate level when using your NURATRUE for an extended period of time.

## Adjusting your Active Noise Cancellation (ANC)/ Social Mode

Active Noise Cancellation reduces outside noise so you can focus on your music.

Social Mode passes outside sound into your NURATRUE so you can hear conversations and your surroundings.

You can adjust ANC/ Social Mode via the Touch Buttons or in-app:

### Touch Buttons

You can assign Social Mode to the Tap function on either side by customising the Tap functions within the Nura app. Doing so will simply toggle Social Mode On/Off.

### In-app

1. Tap the Social Mode button on the homepage of the Nura app.

### Turning ANC Off/On:

1. Open the Nura app with your NURATRUE connected via Bluetooth to your device.
2. Tap on the Menu icon at the top left (☰).
3. Tap on **Device settings**.
4. Scroll down to **Enable Social Mode & ANC (Active Noise Cancellation)**,
5. Tap on the setting to toggle it on or off.

## Changing the NURATRUE Voice Language

The NURATRUE voice guides you through personalising your NURATRUE, announces the battery level and identifies connected devices. To change the language:

Open the Nura app.

Tap on the Menu icon at the top left (☰).

Tap on **Device settings > Change voice language**.

Choose your preferred language.

To confirm the change, tap **Yes**.

Please note: it takes approximately 10 minutes for the voice language to change. The NURATRUE needs to install new software to change your language.



## Switching, Adding and Deleting Hearing Profiles

You can store up to three hearing profiles on your NURATRUE at a time.

### Switching profiles:

1. Open the Nura app.
2. Tap **Switch Profile** on the Nura app homepage at the top left.
3. Tap the hearing profile you'd like to switch to.

### Adding a hearing profile:

1. Open the Nura app.
2. Tap **Add Profile** on the Nura app homepage at the top centre.
3. If you own the NURATRUE you're using, select **Owner**. If you're using someone else's NURATRUE, select **Another Person**.
4. Follow the app prompts to add your new hearing profile.

### Deleting a hearing profile:

1. Open the Nura app.
2. Tap on the Menu icon at the top left (☰).
3. Tap on **Device Settings**. Scroll down and tap on **Delete Hearing Profile**.
4. Select the hearing profile you'd like to delete.
5. The Nura app confirms your hearing profile has been deleted.



# Troubleshooting

If you're ever having trouble with your NURATRUE, read the following troubleshooting.

## Resetting your NURATRUE

### Device Reset

1. Hold down the touch buttons on both sides of the NURATRUE for 10 seconds to reset.

### Factory Reset

1. Open the Nura app.
2. Tap **Menu > Device settings > Perform Factory Reset**

Note: this will delete your hearing profiles.

## If Your NURATRUE Won't Charge

- Make sure you're charging with the NURATRUE USB-C cable only.
- If you're trying to charge with a computer, then try using a different USB port or a wall charger.
- If you're trying to charge with a wall charger, then try charging with a computer.
- If you're attempting to charge with a USB hub, then make sure it's powered.

## If Your NURATRUE Won't Perform the Personalisation Process

- Check our **Fitting your NURATRUE** guide in **Getting Started** to ensure you have the correct fit.
- Make sure your NURATRUE is sitting securely in your ears, remove any accessories which sit near your ears, and if you have long hair, tie it back.
- Check there are no obstructions blocking the mesh e.g. wax build up, packaging remnants etc. Any blockages will impact the ability of the NURATRUE to detect your hearing.
- Make sure you're in a quiet place, sit still and try not to talk during personalisation.
- Check you have a stable internet and Bluetooth connection
- Check your mobile device and the Nura app have been updated to the latest version.

### Further troubleshooting:

1. 'Forget' your NURATRUE from your device's Bluetooth settings, and pair again.
2. Reset the device you are trying to connect to.
3. Delete and reinstall the Nura app.
4. Reset your NURATRUE.
5. Clean your NURATRUE.



## If Your NURATRUE Won't Connect to the Nura App:

- Check your mobile device and the Nura app have been updated to the latest version.
- Close and re-open the Nura app.
- Check your NURATRUE is connected to your mobile device with Bluetooth. You need to be connected with Bluetooth to use the Nura app. Bluetooth will only activate when no cables are connected.
- Check your internet connection is stable.
- Delete the Nura app, restart your mobile device and then reinstall the Nura app.
- Reset your NURATRUE.

## If You're Having Trouble Connecting Your NURATRUE via Bluetooth:

- Check your NURATRUE and device are charged.
- Ensure your NURATRUE and device are within 10 feet of each other.
- Check you're connecting to **NURATRUE XXX**, not **NURATRUE XXX[LE]**.
- NURATRUE XXX [LE] is the NURATRUE low-energy mode, which will automatically connect after you've connected to **NURATRUE XXX**.
- Move away from other Bluetooth devices, microwaves and wireless routers to avoid interference.

### Further troubleshooting:

- Re-start your device and try pairing your NURATRUE with Bluetooth again.
- If you've previously paired your NURATRUE with Bluetooth, then remove your NURATRUE from your device's paired device list and try pairing again.
- Reset your NURATRUE.

## Bluetooth Cutting In and Out?

Bluetooth is designed for short distances, so you might experience some interference from time to time. To minimise Bluetooth interference, try the following:

- Move your paired device closer to the NURATRUE
- Move your NURATRUE and device away from other Bluetooth devices, microwaves and wireless routers.
- Update your NURATRUE and mobile device to the latest versions.

## If You're Having Trouble Making Calls With Your NURATRUE:

Follow these steps if you're having trouble making and receiving phone calls, or calls via Skype, FaceTime or other calling apps.

- Check your NURATRUE is connected with Bluetooth.
- Check that nothing is blocking your NURATRUE microphones.
- The microphones are located on each side of your NURATRUE.
- Disconnect your NURATRUE from your device and then reconnect.





- Check your Bluetooth connection.
- Poor call quality can be caused by a poor Bluetooth connection.
- Reset your NURATRUE.

## **If You're Having Trouble With Sound Quality:**

To get the highest sound quality from your NURATRUE:

- Use a lossless file format, such as AIFF, WAV or FLAC.
- Use a lossless streaming service, such as Tidal.
- If you're using Spotify or a similar streaming service, use the high-quality streaming option. Ensure to check the streaming quality options in the platform's settings.
- Check the device is not in Social Mode.
- If you're using MP3 or MP3-like files, use high-bitrate MP3, Ogg or AAC files. Or use minimum 256kbps (and preferably 320kbps) files with modern codecs.
- Personalise your NURATRUE again.  
The NURATRUE uses sensitive microphones to personalise, so movements, outside noises and heavy breathing can affect your hearing profile.

## **If the Touch Buttons Aren't Working Correctly:**

1. Check your NURATRUE touch buttons have been set-up correctly via the nura app.
2. Reset your NURATRUE.

## **Can't Find What You're Looking For? Try the Following:**

- Check your NURATRUE is charged.
- Check your mobile device and the Nura app have been updated to the latest version.
- Check your Bluetooth is connected.

### **Further Troubleshooting**

1. Forget your NURATRUE from your device's Bluetooth settings, and pair again.
2. Reset the device which you are trying to connect to.
3. Delete and reinstall the Nura app.
4. Reset your NURATRUE.
5. Clean your NURATRUE.

## **Need more help?**

Check our in-depth online help & support site [nura.co/support](https://nura.co/support)

You can also contact us via email and live chat at [nura.co/contact](https://nura.co/contact)

## **Warranty**

Your NURATRUE is covered by a one-year limited warranty. Find out more at [nura.co/returns](https://nura.co/returns)



# Compliance

nura® adheres to the certification requirements for various regions around the world. For a full list of certifications please visit: [nura.co/compliance](https://nura.co/compliance)



This equipment has been tested and found to comply with the limits for a Class B digital device, pursuant to Part 15 of the FCC Rules. These limits are designed to provide reasonable protection against harmful interference in a residential installation. This equipment generates, uses, and can radiate radio frequency energy and, if not installed and used in accordance with the instructions, may cause harmful interference to radio communications. However, there is no guarantee that interference will not occur in a particular installation. If this equipment does cause harmful interference to radio or television reception, which can be determined by turning the equipment off and on, the user is encouraged to try to correct the interference by one or more of the following measures:

Reorient or relocate the receiving antenna.

Increase the distance between the equipment and receiver.

Connect the equipment into an outlet on a circuit different from that to which the receiver is connected.

Changes or modifications not expressly approved by NURA® could void the user's authority to operate this equipment.

This device complies with Part 15 of the FCC Rules. Operation is subject to the following two conditions: (1) this device may not cause harmful interference, and (2) this device must accept any interference received, including interference that may cause undesired operation.

47 CFR § 2.1077 Compliance Information  
Responsible Party – U.S. Contact Information:

Nura USA Operations Inc.  
1375 Broadway, 15th Floor, New York, NY 10018 USA  
[compliance@nura.co](mailto:compliance@nura.co)



IC Warning:

This device contains licence-exempt transmitter(s)/receiver(s) that comply with Innovation, Science and Economic Development Canada's licence-exempt RSS(s).

Operation is subject to the following two conditions:

1. This device may not cause interference.
2. This device must accept any interference, including interference that may cause undesired operation of the device.

L'émetteur exempt de licence contenu dans le présent appareil est conforme aux CNR d'Innovation, Sciences et Développement économique Canada applicables aux appareils radio exempts de licence. L'exploitation est autorisée aux deux conditions suivantes :



1. L'appareil ne doit pas produire de brouillage;
2. L'appareil doit accepter tout brouillage radioélectrique subi, même si le brouillage est susceptible d'en compromettre le fonctionnement.

This equipment complies with IC RSS-102 radiation exposure limits set forth for an uncontrolled environment. This transmitter must not be co-located or operating in conjunction with any other antenna or transmitter.

Cet équipement est conforme aux limites d'exposition aux radiations IC CNR-102 établies pour un environnement non contrôlé. Cet émetteur ne doit pas être situé ou fonctionner conjointement avec une autre antenne ou un autre émetteur.

CAN ICES-3 (B)/NMB-3(B)



The product is only guaranteed to comply with EN50332 in generic mode with immersion off with the volume limiter on. Depending on the hearing of the user, some combinations of hearing corrections and immersion setting may exceed EN50332 limits.

To prevent possible hearing damage, do not listen at high levels for long periods.

This device may be operated in all member states of the EU. Declaration for EU compliance:  
Operation Frequency Band/Max. RF power transmitted: 2400-2483.5 MHz.

Hereby, nura® Operations Pty. Ltd declares that the radio equipment type 'E00B' is in compliance with Directive 2014/53/EU. The full text of the EU declaration of conformity is available at the following internet address: [www.nura.co/NURABUDS/compliance](http://www.nura.co/NURABUDS/compliance)

Focus on your safety and that of others if you use the headphones while engaging in any activity requiring your attention. You may remove the headphones or adjust your volume to ensure you can hear surrounding sounds, including alarms and warning signals.

Do not use the headphones if they emit any loud or unusual noise. If this happens, take the headphones off and contact Nura customer service.

Do not submerge or expose the headphones to water, or wear while participating in water sports, e.g., swimming, surfing etc.

#### CAUTION

the battery shall not be exposed to excessive heat such as sunshine, fire or the like

DISPOSE OF USED BATTERIES ACCORDING TO THE INSTRUCTIONS

Disposal of a battery into fire or a hot oven, or mechanically crushing or cutting of a battery can result in an explosion.

Leaving a battery in an extremely high temperature surrounding environment can result in an explosion or the leakage of flammable liquid or gas.

A battery subjected to extremely low air pressure may result in an explosion or the leakage of flammable liquid or gas.



取得審驗證明之低功率射頻器材，非經核准，公司、商號或使用者均不得擅自變更頻率、加大功率或變更原設計之特性及功能。

低功率射頻器材之使用不得影響飛航安全及干擾合法通信；經發現有干擾現象時，應立即停用，並改善至無干擾時方得繼續使用。



前述合法通信，指依電信管理法規定作業之無線電通信。

低功率射頻器材須忍受合法通信或工業、科學及醫療用電波輻射性電機設備之干擾。



This symbol means the product must not be discarded as household waste, and should be delivered to an appropriate collection facility for recycling. Proper disposal and recycling helps protect natural resources, human health and the environment. For more information on disposal and recycling of this product, contact your local municipality, disposal service, or the shop where you bought this product.

Apple, the Apple logo, iPad, iPhone, and iPod are trademarks of Apple Inc., registered in the U.S. and other countries. App Store is a service mark of Apple Inc.

The trademark "iPhone" is used with a license.

The Bluetooth® word mark and logos are registered trademarks owned by Bluetooth SIG, Inc. and any use of such marks by nura® Operations Pty. Ltd. is under license.

Qualcomm aptX is a product of Qualcomm Technologies International, Ltd. Qualcomm is a trademark of Qualcomm Incorporated, registered in the United States and other countries, used with permission. aptX is a trademark of Qualcomm Technologies International, Ltd., registered in the United States and other countries, used with permission.

Android, Google Play and the Google Play logo are trademarks of Google Inc. The NURABUDS are designed by nura® in Melbourne, Australia.

Made and assembled in China.

© 2021 nura® Pty. Ltd. No part of this work may be reproduced, modified, distributed or otherwise used without prior written permission.



Qualcomm® aptX™



Bluetooth™

