



EMC TEST REPORT

For

HUMIDIFIER

Model No.: X12, X13

Prepared for : Shenzhen JiaHe Precision Mold Co., Limited
Address : 1st Floor, Fushijinggong, Longxin Industrial Park, 3rd Fenghuang Industrial Area,
Fuyong, Bao' An District, Shenzhen, China.

Prepared By : Shenzhen KAIXU Testing Technology Co., Ltd
Address : Room 316, 3rd Floor, Building A, Jinbolong Industrial Park, Longhua Street, Longhua
District, Shenzhen

Tel : +86-755-85254458
Fax : +86-755-85254458
Web : www.kti-lab.com

Report Number : KTi210429E069
Date of Receipt : April 22, 2021
Date of Test : April 22-29, 2021
Date of Report : April 29, 2021

Table of Contents

1 General Description.....	5
1.1 Description of EUT.....	5
1.2 Test mode.....	5
1.3 Test setup.....	5
1.4 Ancillary equipment.....	5
2 Summary of Test Result.....	6
3 Test Facilities and Accreditations.....	7
3.1 Test laboratory.....	7
3.2 Environmental conditions.....	7
3.3 Measurement uncertainty.....	7
3.4 Test software.....	7
4 List of test equipment.....	8
5 Emission test.....	10
5.1 Conducted emission.....	10
5.2 Radiated emission.....	11
5.3 Harmonic current emission / Voltage fluctuations & flicker.....	15
6 Immunity test.....	16
6.1 Performance criteria.....	16
6.2 Electrostatic discharge (ESD).....	17
6.2.1. <i>Test Procedures</i>	17
6.2.2. <i>Test Setup</i>	17
6.2.3. <i>Test Result</i>	17
6.3 Radiated electromagnetic field immunity (RS).....	19
6.3.1. <i>Test Procedures</i>	19
6.3.2. <i>Test setup</i>	19
6.3.3. <i>Test Result</i>	19
6.4 Conducted disturbances (CS).....	20
6.4.1. <i>Test Procedures</i>	20
6.4.2. <i>Test Setup</i>	20
6.4.3. <i>Test Result</i>	20
6.5 Power frequency magnetic field.....	21
6.5.1. <i>Test Procedures</i>	21
6.5.2. <i>Test Setup</i>	21
6.5.3. <i>Test Result</i>	21
6.6 Electrical fast transients/burst (EFT/S).....	22
6.6.1. <i>Test Procedures</i>	22
6.6.2. <i>Test Setup</i>	22
6.6.3. <i>Test Result</i>	22
6.7 Surges.....	23
6.7.1. <i>Test Procedures</i>	23
6.7.2. <i>Test Setup</i>	23
6.7.3. <i>Test Result</i>	23
6.8 Voltage dips and interruptions.....	24
6.8.1. <i>Test procedures</i>	24
6.8.2. <i>Test setup</i>	24
6.8.3. <i>Test result</i>	24
6.9 Broadband Impulse noise disturbances repetitive.....	25
6.9.1. <i>Test procedures</i>	25
6.9.2. <i>Test setup</i>	25
6.9.3. <i>Test result</i>	25
6.10 Broadband Impulse noise disturbances isolated.....	26

6.10.1. Test procedures.....	26
6.10.2. Test setup.....	26
6.10.3. Test result.....	26
Photographs of the test photo.....	27
Photographs of the EUT.....	29

Test Result Certification

Applicant's name: Shenzhen JiaHe Precision Mold Co., Limited

Address: 1st Floor, Fushijinggong, Longxin Industrial Park, 3rd Fenghuang Industrial Area, Fuyong, Bao' An District, Shenzhen, China.

Manufacture's Name: Shenzhen JiaHe Precision Mold Co., Limited

Address: 1st Floor, Fushijinggong, Longxin Industrial Park, 3rd Fenghuang Industrial Area, Fuyong, Bao' An District, Shenzhen, China.

Product name: HUMIDIFIER

Model name: X12, X13

Trademark: /

Standards: EN 55014-1:2017
EN 55014-2:2015
EN IEC 61000-3-2:2019
EN 61000-3-3:2013+A1:2019

This device described above has been tested by Shenzhen KAIXU Testing Technology Co., Ltd. and the test results show that the equipment under test (EUT) is in compliance with the EMC requirements. And it is applicable only to the tested sample identified in the report.

Tested by: 
Eric Zhang April 29, 2021

Reviewed by: 
Terry Huang April 29, 2021

Approved by: 
Store Chu April 29, 2021



1 General Description

1.1 Description of EUT

Product name:	HUMIDIFIER
Model name:	X12
Series Model:	X13
Different of series model:	/
Power supply:	DC 5V From USB
Adapter information:	N/A

1.2 Test mode

To investigate the maximum EMI emission characteristics generates from EUT, the test system was pre-scanning tested base on the consideration of following EUT operation mode or test configuration mode which possible have effect on EMI emission level. Each of these EUT operation mode(s) or test configuration mode(s) mentioned above was evaluated respectively.

Test mode	Description
Mode 1	Working
<i>Note: The test modes were carried out for all operation modes. The final test mode of the EUT was the worst test mode for EMI, and its test data is showed.</i>	

1.3 Test setup

See photographs of the test setup in the report for the actual setup and connections between EUT and support equipment.

1.4 Ancillary equipment

Equipment	Model	S/N	Manufacturer
Adapter	/	/	/

2 Summary of Test Result

No.	Test Standard	Description of Test	Result	Remark
Emission				
1	EN 55014-1	Conducted emission	N/A	
2		Radiated emission	Pass	
3	EN IEC 61000-3-2:2019	Harmonic current emission	N/A	
4	EN 61000-3-3:2013+A1:2 019	Voltage fluctuations & flicker	N/A	
Immunity				
1	EN 55014-2	Electrostatic discharges (ESD)	Pass	
2		Radiated electromagnetic field disturbances (RS)	Pass	
3		Conducted disturbances (CS)	N/A	
4		Power frequency magnetic field	N/A	
5		Electrical fast transients/burst (EFT/S)	N/A	
6		Surges	N/A	
7		Voltage dips and interruptions	N/A	
8		Broadband Impulse noise disturbances repetitive	N/A	
9		Broadband Impulse noise disturbances isolated	N/A	
<i>N/A: Mean not applicable.</i>				

3 Test Facilities and Accreditations

3.1 Test laboratory

Test Site	Shenzhen KAIXU Testing Technology Co., Ltd
Test Site Location	Room 316, 3rd Floor, Building A, Jinbolong Industrial Park, Longhua Street, Longhua District, Shenzhen
Telephone:	(86-755)-85254458
Fax:	(86-755)-85254458
CNAS Registration No.:	/

3.2 Environmental conditions

During the measurement the environmental conditions were within the listed ranges:

Temperature:	20°C~30°C
Humidity	30%~70% (30%~60% for ESD)
Atmospheric pressure	98kPa~101kPa

3.3 Measurement uncertainty

Measurement Uncertainty for a Level of Confidence of 95 %, $U=2xUc(y)$

Conducted emission(150kHz~30MHz)	± 2.5 dB
Radiated emission(30MHz~1GHz)	± 4.2 dB
Radiated emission (above 1GHz)	± 4.3 dB
Temperature	±1 degree
Humidity	± 5 %

3.4 Test software

Software name	Manufacturer	Model	Version
EMI Measurement Software	Farad	EZ-EMC	V1.1.4.2
Conducted immunity test system	Scholder	EN61000-4-6.exe	V1.3.0
Harmonics and flicker test system	TTI	HA-PC Link	V2.02
DIPS Test Firmware	Prima	DRP61011AG	V4.1.2
EFT Test Firmware	HTEC	HCOMPACT	V1.0.1
Surge Test Firmware	HTEC+	HCOMPACT	V1.0.1

4 List of test equipment

Radiation emission							
Item	Equipment name	Equipment No.	Manufacturer	Model	Serial No.	Calibration date	Due date
1	EMI Test Receiver	MTI-E004	Rohde&schwarz	ESPI	1000314	2020/10/06	2021/10/05
2	Broadband antenna	MTI-E006	schwarabeck	VULB9163	872	2020/10/06	2021/10/05
3	Horn antenna	MTI-E007	schwarabeck	BBHA9120D	1201	2020/10/06	2021/10/05
4	amplifier	MTI-E014	America	8447D	3113A06150	2020/10/06	2021/10/05
5	amplifier	MTI-E034	Agilent	8449B	3008A02400	2020/10/06	2021/10/05
6	18-40GHz amplifier	MTI-E052	Chengdu step Micro Technology	ZLNA-18-40G-21	1608001	2020/10/06	2021/10/05
7	spectrum analyzer	MTI-E049	Rohde&schwarz	FSP-38	100019	2020/10/06	2021/10/05
8	15-40G Antenna	MTI-E053	Schwarzbeck	BBHA9170	BBHA9170582	2020/10/06	2021/10/05
9	Active Loop Antenna 9kHz - 30MHz	MTI-E051	Schwarzbeck	FMZB 1519 B	00044	2020/10/06	2021/10/05

Conduction emission							
Item	Equipment name	Equipment No.	Manufacturer	Model	Serial No.	Calibration date	Due date
1	Artificial power network	MTI-E037	Schwarzbeck	NSLK8127	NSLK8127#841	2020/10/06	2021/10/05
2	EMI Test Receiver	MTI-E003	Rohde&schwarz	ESCI	101368	2020/10/06	2021/10/05
3	Artificial power network	MTI-E058	Schwarzbeck	NSLK8127	NSLK8127#841	2020/10/06	2021/10/05

Conduction immunity							
Item	Equipment name	Equipment No.	Manufacturer	Model	Serial No.	Calibration date	Due date
1	Conduction Immunity Signal Generator	MTI-E015	Schloder	CDG6000	126A1343/2015	2020/10/06	2021/10/05
2	Coupled decoupling network	MTI-E016	Schloder	CDA M2/M3	A2210332/2015	2020/10/06	2021/10/05

Voltage dips, short interruptions and voltage variations immunity							
Item	Equipment name	Equipment No.	Manufacturer	Model	Serial No.	Calibration date	Due date
1	Drop generator	MTI-E025	Prima/China	DRP61011AG	PR15056303	2020/10/06	2021/10/05

Working frequency magnetic field immunity							
Item	Equipment name	Equipment No.	Manufacturer	Model	Serial No.	Calibration date	Due date
1	power frequency magnetic field generator	MTI-E011	china HTEC	HPFMF 100	153703	2020/10/06	2021/10/05

Electrostatic discharge immunity							
Item	Equipment name	Equipment No.	Manufacturer	Model	Serial No.	Calibration date	Due date
1	ESD Simulator	MTI-E008	Schloder	SESD 30000	509325	2020/10/06	2021/10/05

Surge immunity							
Item	Equipment name	Equipment No.	Manufacturer	Model	Serial No.	Calibration date	Due date
1	Surge Generator	MTI-E010	china HTEC	HCWG 51	153702	2020/10/06	2021/10/05

Harmonic & flicker emissions							
Item	Equipment name	Equipment No.	Manufacturer	Model	Serial No.	Calibration date	Due date
1	AC power source	MTI-E023	shenzhen tongyuan	TY-8205	20150916809	2020/10/06	2021/10/05
2	Harmonic scintillation Analyzer	MTI-E013	Laplace	AC2000A	311216	2020/10/06	2021/10/05

Electrical Fast Transient/Burst immunity							
Item	Equipment name	Equipment No.	Manufacturer	Model	Serial No.	Calibration date	Due date
1	Electrical Fast Transient Generator	MTI-E009	HTEC	HEFT 51	153701	2020/10/06	2021/10/05

Radiated electromagnetic field immunity					
Equipment	Manufacturer	Model	Serial No.	Calibration date	Due date
Signal Generator	R&S	SMB100A	106148	2020/10/06	2021/10/05
RF Power Amplifier	BONN Elektronik	STLP9128D	128740	2020/10/06	2021/10/05
Gestockte Breitband (S tacked) Log. -per.Antenna	SCHWARZBECK	STLP9128D	043	2020/10/06	2021/10/05
Power Meter	R&S	NRP2	102031	2020/10/06	2021/10/05
Amplifier	NJNT	NTWPAS-2560 025	2560025	2020/10/06	2021/10/05
Broad-band Horn Antenna	SCHWARZBECK	BBHA 9120 D	BBHA9120D-667	2020/10/06	2021/10/05

Note: the calibration interval of the above test instruments is 12 months and the calibrations are traceable to international system unit (SI).

5 Emission test

5.1 Conducted emission

5.1.1 Limits

Frequency (MHz)	Class A (dB μ V)		Class B (dB μ V)	
	Quasi-peak	Average	Quasi-peak	Average
0.15 -0.5	79	66	66 - 56 *	56 - 46 *
0.5 -5	73	60	56	46
5 -30	73	60	60	50

Note 1: the tighter limit applies at the band edges.

*Note 2: the limit of " * " marked band means the limitation decreases linearly with the logarithm of the frequency in the range.*

5.1.2 Test Procedures

- a) The EUT was placed 0.8 meters from the horizontal ground plane with EUT being connected to the power mains through a line impedance stabilization network (LISN). All other support equipment powered from additional LISN(s). The LISN provide 50 Ohm/ 50uH of coupling impedance for the measuring instrument.
- b) Interconnecting cables that hang closer than 40 cm to the ground plane shall be folded back and forth in the center forming a bundle 30 to 40 cm long.
- c) I/O cables that are not connected to a peripheral shall be bundled in the center. The end of the cable may be terminated, if required, using the correct terminating impedance. The overall length shall not exceed 1 m.
- d) LISN is at least 80 cm from nearest part of EUT chassis.
- e) For the actual test configuration, please refer to the related Item – photographs of the test setup.

5.1.3 Test setup

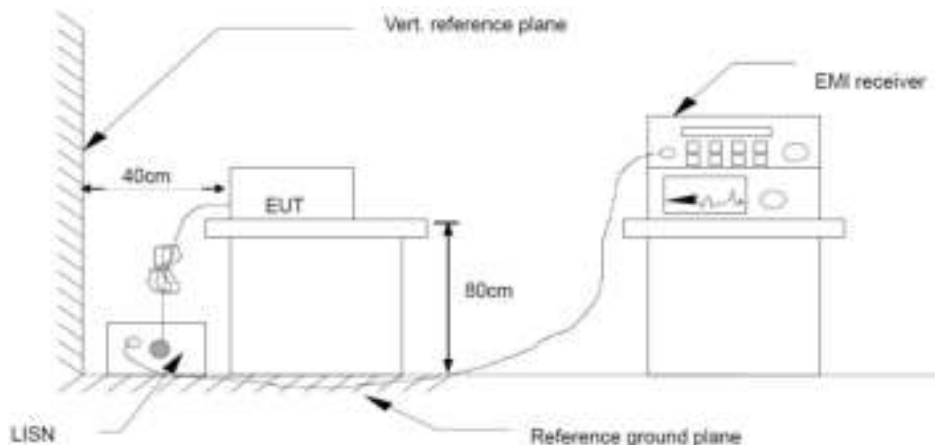

5.1.4 Test Result

Not applicable (EUT Power supply by USB 5V)

5.2 Radiated emission

5.2.1 Limits

Frequency (MHz)	Class A (at 3m) dB μ V/m		Class B (at 3m) dB μ V/m	
	Quasi-peak		Quasi-peak	
30-230	50		40	
230-1000	57		47	
/	Peak	Average	Peak	Average
1000-3000	76	56	70	50
3000-6000	80	60	74	54

5.2.2 Test Procedures

- The radiated emission tests were performed in the 3 meters.
- The EUT was placed on the top of a rotating table 0.8 meters above the ground. The table was rotated 360 degrees to determine the position of the highest radiation.
- The height of the test antenna shall vary between 1m to 4m. Both horizontal and vertical polarizations of the antenna are set to make the measurement.
- If the peak mode measured value compliance with and lower than quasi peak mode limit, the EUT shall be deemed to meet QP limits and then no additional QP mode measurement performed.
- If the peak mode measured value compliance with and lower than average mode limit, the EUT shall be deemed to meet average limits and then no additional average mode measurement performed.
- For the actual test configuration, please refer to the related item – EUT test photos.

5.2.3 Test Setup

Radiated emission test-up frequency for 30MHz - 1GHz

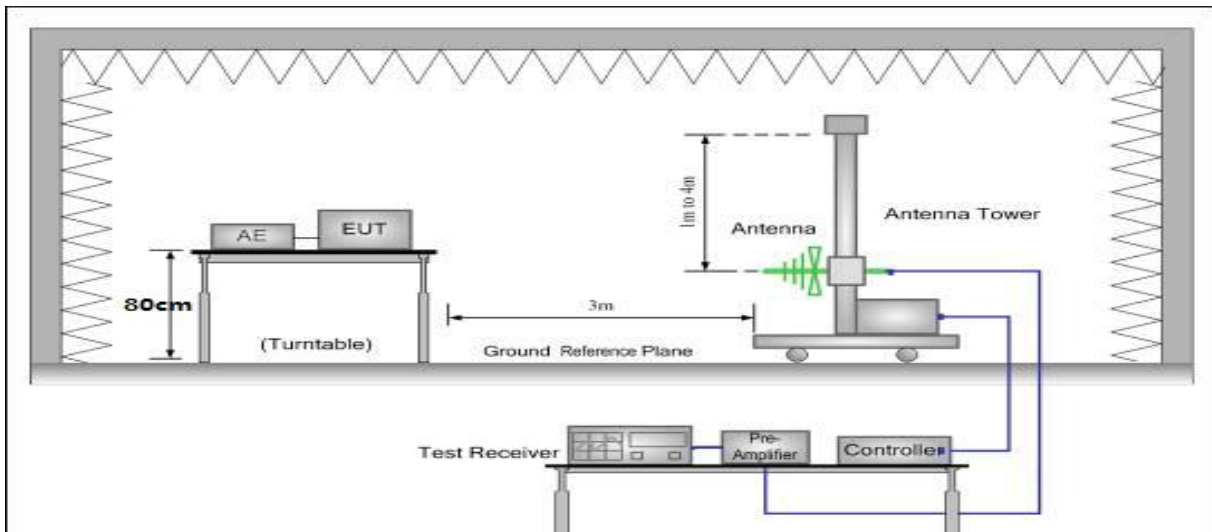

Radiated emission test-up frequency for above 1GHz

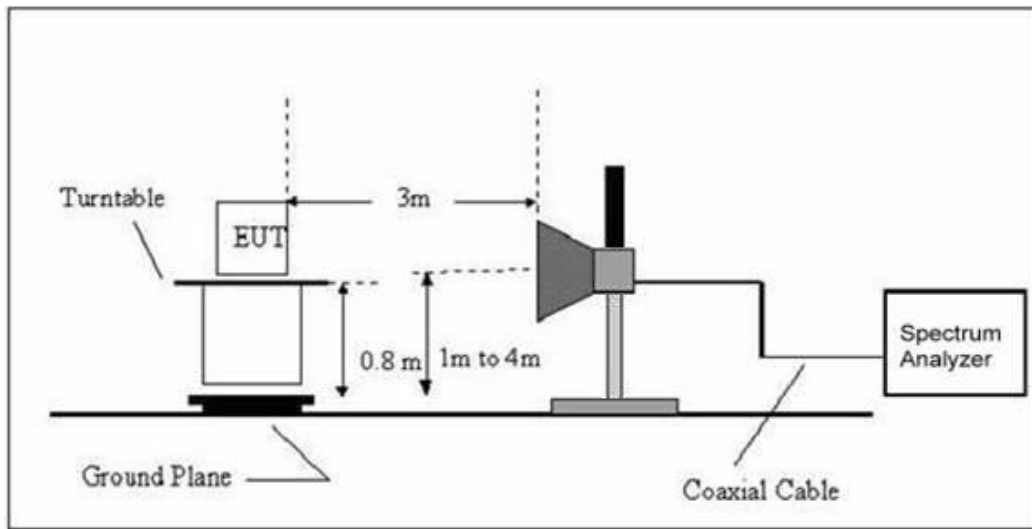

5.2.4 Test Result

Note: the highest working frequency of EUT is below 108MHz.

EUT:	HUMIDIFIER	Model Number:	X12
Test voltage:	DC 5.0V	Test mode:	Mode 1
Pressure:	101kPa	Polarization:	Horizontal
Temperature:	25°C	Relative Humidity:	56%

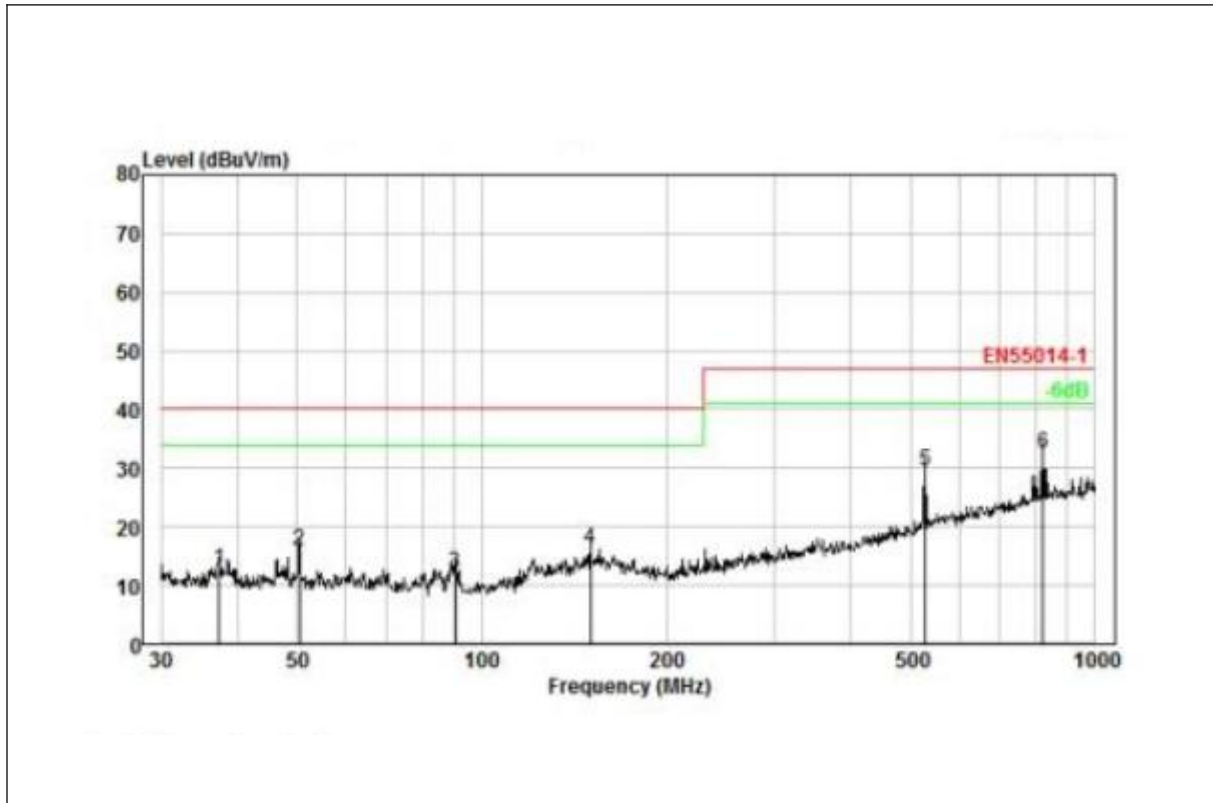

Env. / Ins. :

No.	Freq MHz	Cable Loss dB	ANT Factor dB/m	Receiver Reading dBUV	Preamp Factor dB	Emission Level dBUV/m	Limit dBUV/m	Over Limit dB	Remark
1.	37.285	1.58	12.15	29.00	29.90	12.83	40.00	-27.17	QP
2.	50.409	2.09	12.10	31.59	29.92	15.86	40.00	-24.14	QP
3.	90.537	3.10	9.19	29.85	29.98	12.16	40.00	-27.84	QP
4.	150.538	3.98	13.73	28.40	30.02	16.09	40.00	-23.91	QP
5.	528.246	6.13	17.91	36.53	30.93	29.64	47.00	-17.36	QP
6.	821.710	6.90	21.49	35.25	31.14	32.50	47.00	-14.50	QP

EUT:	HUMIDIFIER	Model Number:	X12
Test voltage:	DC 5.0V	Test mode:	Mode 1
Pressure:	101kPa	Polarization:	Vertical
Temperature:	25°C	Relative Humidity:	56%

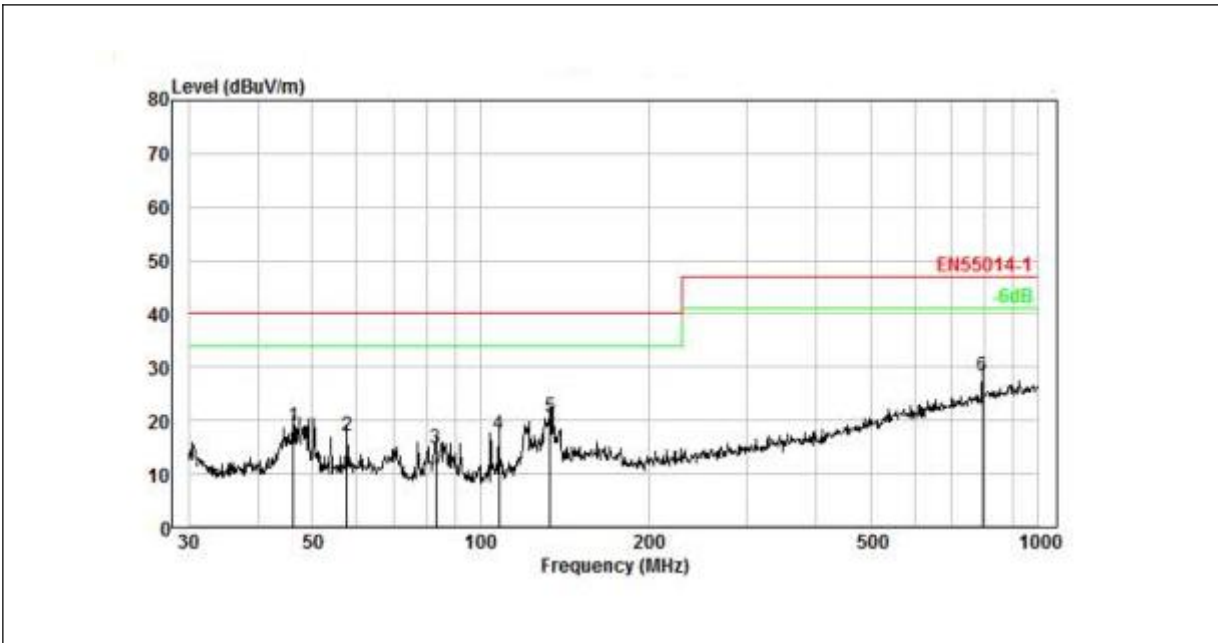

Env./Ins. :

No.	Freq MHz	Cable Loss dB	ANT Factor dB/m	Receiver Reading dBuV	Preamp Factor dB	Emission Level dBuV/m	Limit dBuV/m	Over Limit dB	Remark
1.	46.178	1.94	12.25	34.75	29.92	19.02	40.00	-20.98	QP
2.	57.594	2.32	11.89	32.95	29.93	17.23	40.00	-22.77	QP
3.	83.230	2.96	8.80	32.96	29.97	14.75	40.00	-25.25	QP
4.	107.888	3.40	10.56	33.38	30.00	17.34	40.00	-22.66	QP
5.	133.151	3.77	12.88	34.07	30.01	20.71	40.00	-19.29	QP
6.	793.396	6.84	21.31	31.38	31.16	28.37	47.00	-18.63	QP

5.3 Harmonic current emission / Voltage fluctuations & flicker

5.3.1 Test Procedures

- a) The EUT was installed and placed on a non-conductive table and operated to produce the maximum harmonic components under normal operating conditions for each successive harmonic component in turn.
- b) The correspondent test program of test instrument to measure the current harmonics / voltage fluctuations & flicker emanated from EUT. The measure time shall be not less than the time necessary for the EUT to be exercised.

5.3.2 Test Setup

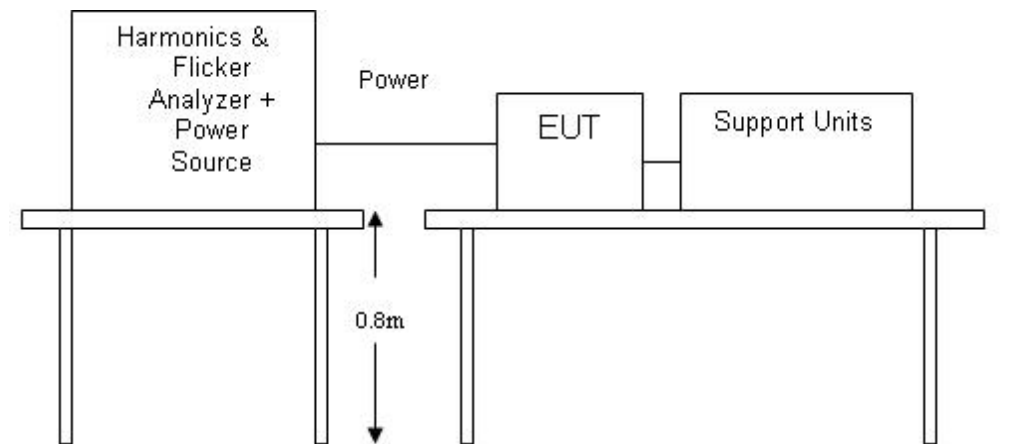

5.3.3 Test Result

Harmonic current emission:

Not applicable (EUT Power supply by USB 5V)

Voltage fluctuations & flicker:

Not applicable (EUT Power supply by USB 5V)

6 Immunity test

6.1 Performance criteria

Performance criteria	
Performance criterion	Description
A	<p>During and after the test the EUT shall continue to operate as intended without operator intervention. No degradation of performance or loss of function is allowed below a minimum performance level specified by the manufacturer when the EUT is used as intended. The performance level may be replaced by a permissible loss of performance. If the minimum performance level or the permissible performance loss is not specified by the manufacturer, then either of these may be derived from the product description and documentation, and by what the user may reasonably expect from the EUT if used as intended.</p>
B	<p>After the test, the EUT shall continue to operate as intended without operator intervention. No degradation of performance or loss of function is allowed, after the application of the phenomena below a performance level specified by the manufacturer, when the EUT is used as intended. The performance level may be replaced by a permissible loss of performance.</p> <p>During the test, degradation of performance is allowed. However, no change of operating state or stored data is allowed to persist after the test.</p> <p>If the minimum performance level (or the permissible performance loss) is not specified by the manufacturer, then either of these may be derived from the product description and documentation, and by what the user may reasonably expect from the EUT if used as intended.</p>
C	<p>During and after testing, a temporary loss of function is allowed, provided the function is self-recoverable, or can be restored by the operation of the controls or cycling of the power to the EUT by the user in accordance with the manufacturer's instructions.</p> <p>Functions, and/or information stored in non-volatile memory, or protected by a battery backup, shall not be lost.</p>
<p>Particular performance criteria:</p> <p>The particular performance criteria which are specified in the normative annexes take precedence over the corresponding parts of the general performance criteria. Where particular performance criteria for specific functions are not given, then the general performance criteria shall apply.</p>	

6.2 Electrostatic discharge (ESD)

6.2.1. Test Procedures

- a) The test generator necessary to perform direct and indirect application of discharges to the EUT in the following manner:

Contact discharge was applied to conductive surfaces and coupling planes of the EUT. During the test, it was performed with single discharges. For the single discharge time between successive single discharges was at least 1 second.

- b) Vertical Coupling Plane (VCP):

The coupling plane, of dimensions 0.5m x 0.5m, is placed parallel to, and positioned at a distance 0.1m from, the EUT, with the Discharge Electrode touching the coupling plane. The four faces of the EUT will be performed with electrostatic discharge.

- c) Horizontal Coupling Plane (HCP):

The coupling plane is placed under to the EUT. The generator shall be positioned vertically at a distance of 0.1m from the EUT, with the Discharge Electrode touching the coupling plane. The four faces of the EUT will be performed with electrostatic discharge.

Air discharges at insulation surfaces of the EUT. It was at least ten single discharges with positive and negative at the same selected point. For the actual test configuration, please refer to the related Item –EUT Test Photos.

6.2.2. Test Setup

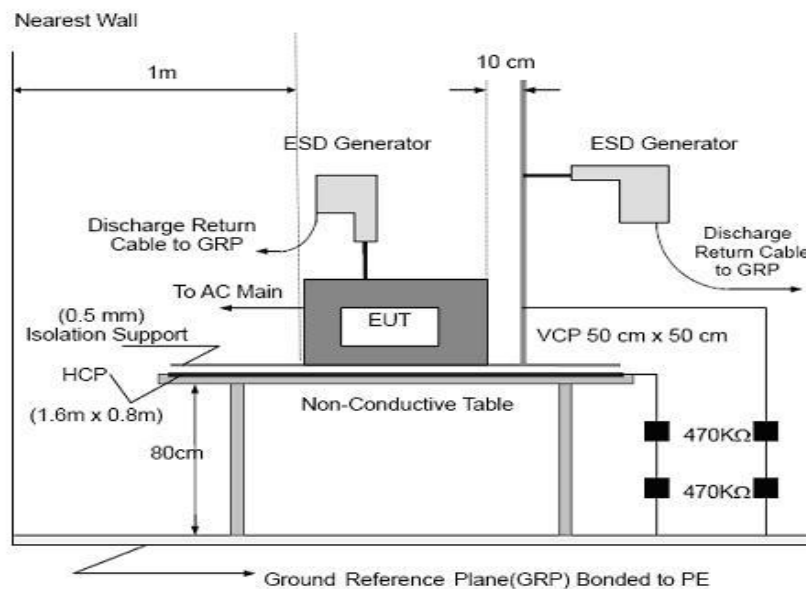

6.2.3. Test Result

Indirect discharge

Temperature:	25°C	Relative Humidity:	54%
Pressure:	101kPa	Test mode:	Mode 1

No.	Test Point	Contact discharge level (kV)	Number and polarity	Criterion met	Criterion Required	Result
1	VCP-Front side	<input type="checkbox"/> ..2 <input checked="" type="checkbox"/> ..4	10 (+)	A	B	Compliance
		<input type="checkbox"/> ..6 <input type="checkbox"/> ..8	10 (-)	A		
2	VCP-Rear side	<input type="checkbox"/> ..2 <input checked="" type="checkbox"/> ..4	10 (+)	A		
		<input type="checkbox"/> ..6 <input type="checkbox"/> ..8	10 (-)	A		
3	VCP-Left side	<input type="checkbox"/> ..2 <input checked="" type="checkbox"/> ..4	10 (+)	A		
		<input type="checkbox"/> ..6 <input type="checkbox"/> ..8	10 (-)	A		
4	VCP-Right side	<input type="checkbox"/> ..2 <input checked="" type="checkbox"/> ..4	10 (+)	A		
		<input type="checkbox"/> ..6 <input type="checkbox"/> ..8	10 (-)	A		
5	HCP	<input type="checkbox"/> ..2 <input checked="" type="checkbox"/> ..4	10 (+)	A		
		<input type="checkbox"/> ..6 <input type="checkbox"/> ..8	10 (-)	A		

Direct discharge

No.	Test Point	Contact discharge level (kV)	Air discharge level (kV)	Number and polarity	Criterion met	Criterion Required	Result
1	Each nonconductive location touchable by hand	<input type="checkbox"/> ..2 <input type="checkbox"/> ..4	<input type="checkbox"/> ..2 <input type="checkbox"/> ..4	10 (+)	A	B	Compliance
		<input type="checkbox"/> ..6 <input type="checkbox"/> ..8	<input type="checkbox"/> ..6 <input checked="" type="checkbox"/> ..8	10 (-)	A		
2	Each conductive location touchable by hand	<input type="checkbox"/> ..2 <input type="checkbox"/> ..4	<input type="checkbox"/> ..2 <input type="checkbox"/> ..4	10 (+)	N/A		
		<input type="checkbox"/> ..6 <input type="checkbox"/> ..8	<input type="checkbox"/> ..6 <input type="checkbox"/> ..8	10 (-)	N/A		

Note1: Please see the photographs blew about the details of test points.

6.3 Radiated electromagnetic field immunity (RS)

6.3.1. Test Procedures

- a) The EUT and support equipment, which are placed on a table that is 0.8 meter above ground and the testing was performed in a fully-anechoic chamber.
- b) The testing distance from antenna to the EUT was 3 meters.
- c) The other condition as following manner:
 - i. The field strength level was 3V/m.
 - ii. The frequency range is swept from 80 MHz to 1000 MHz with the signal 80% amplitude modulated with a 1kHz sine wave. The rate of sweep did not exceed 1.5×10^{-3} decade/s. Where the frequency range is swept incrementally, the step size was 1% of fundamental.
- d) The dwell time at each frequency shall be not less than the time necessary for the EUT to be able to respond.
- e) The test was performed with the EUT exposed to both vertically and horizontally polarized fields on each of the four sides.
- f) For the actual test configuration, please refer to the related Item –EUT Test Photos.

6.3.2. Test setup

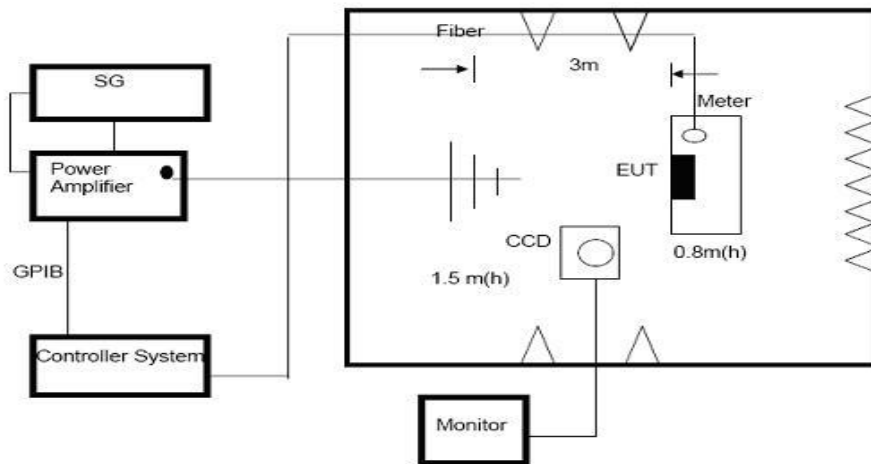

6.3.3. Test Result

Temperature:	25°C	Relative Humidity:	55%
Pressure:	101kPa	Test mode:	Mode 1

Frequency Range (MHz)	RF Field Position	R.F. Field Strength	Azimuth	Perform. Criteria	Measurement	Result
80- 1000 1800 2600 3500 5000	H / V	3 V/m (rms) AM Modulated 1000Hz, 80%	Front	A	A	Compliance
			Rear			
			Left			
			Right			

6.4 Conducted disturbances (CS)

6.4.1. Test Procedures

- a) The EUT are placed on an insulating support 0.1m high above a ground reference plane. CDN (coupling and decoupling device) is placed on the ground plane about 0.3m from EUT. Cables between CDN and EUT are as short as possible, and their height above the ground reference plane shall be between 30 and 50 mm (where possible).
- b) The disturbance signal described below is injected to EUT through CDN.
- c) The EUT operates within its operational mode(s) under intended climatic conditions after power on.
- d) The frequency range is swept from 0.150MHz to 80MHz using 3V signal level, and with the disturbance signal 80% amplitude modulated with a 1 kHz sine wave.
- e) The rate of sweep shall not exceed 1.5×10^{-3} decades/s. Where the frequency is swept incrementally; the step size shall not exceed 1% of the start and thereafter 1% of the preceding frequency value.
- f) Recording the EUT operating situation during compliance testing and decide the EUT immunity criterion.

6.4.2. Test Setup

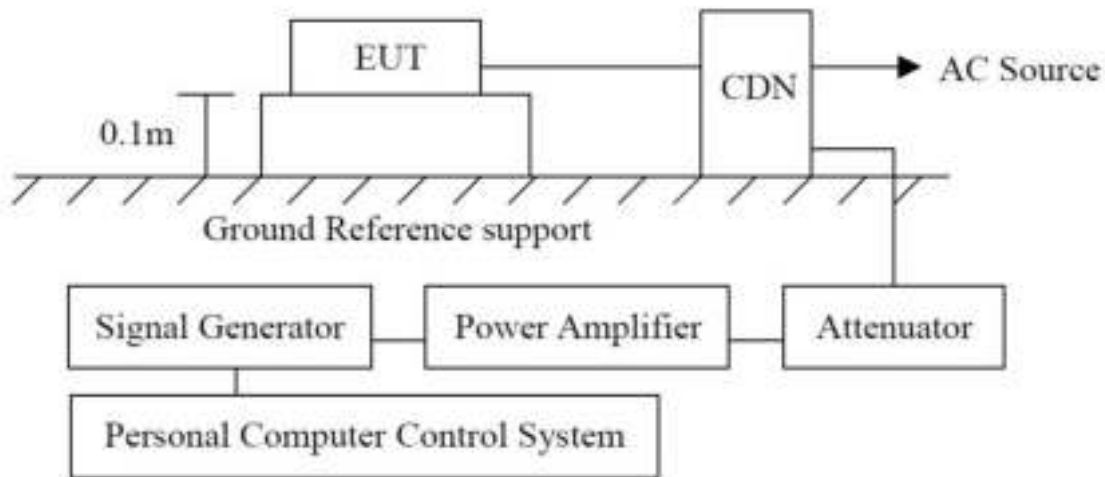

6.4.3. Test Result

Not applicable (EUT Power supply by USB 5V)

6.5 Power frequency magnetic field

6.5.1. Test Procedures

- a) EUT connect the wires according to the typical configuration, and switch on the power supply for 15 minutes.
- b) Turn on the instrument power switch and wait for the instrument to start.
- c) When the device is started, click the Setup icon to enter the settings screen
- d) As shown below, for the settings screen, click the test time position and current position to set the test time and current
- e) Set the correct test time and test current
- f) Click Start to begin the test, while observing the status of EUT and recording

6.5.2. Test Setup

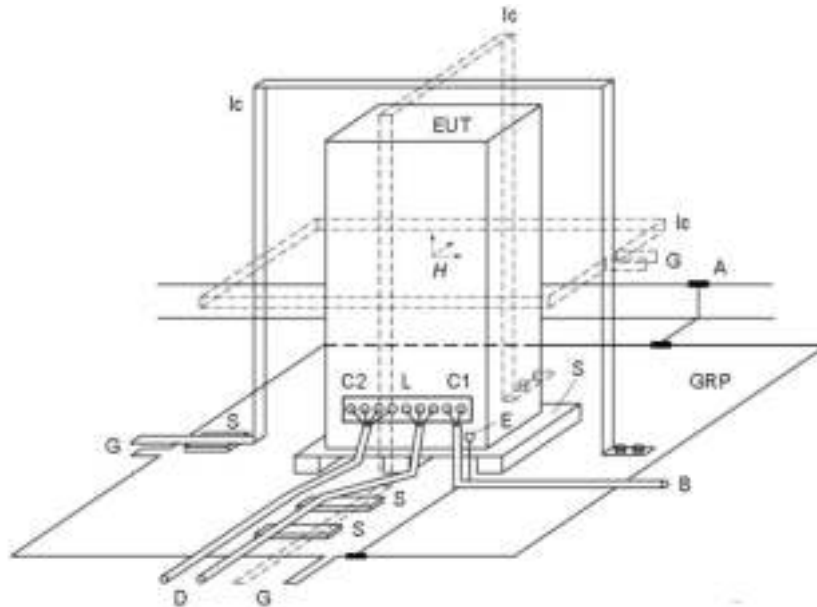

Components:

GRP	Ground plane	A	Safety earth
C1	Power supply circuit	C2	Signal circuit
S	Insulating support	L	Communication line
EUT	Equipment under test	B	To power supply source
Ic	Inductive coil	D	To signal source, simulator
E	Earth terminal	G	To the test generator

6.5.3. Test Result

N/A

6.6 Electrical fast transients/burst (EFT/S)

6.6.1. Test Procedures

a) The EUT and its simulators were placed on the ground reference plane and were insulated from it by a wood support 0.1m + 0.01m thick. The ground reference plane was 1m*1m metallic sheet with 0.65mm minimum thickness. This reference ground plane was project beyond the EUT by at least 0.1m on all sides and the minimum distance between EUT and all other conductive structure, except the ground plane was more than 0.5m. All cables to the EUT was placed on the wood support, cables not subject to EFT/B was routed as far as possible from the cable under test to minimize the coupling between the cables.

b) For input and AC power ports:

The EUT was connected to the power mains by using a coupling device that couples the EFT interference signal to AC power lines. Both positive transients and negative transients of test voltage were applied during compliance test and the duration of the test can't less than 1min.

c) For signal lines and control lines ports:

Ports which are intended to be connected to telecommunication networks (e.g. public switched telecommunication networks, integrated services digital networks, local area networks and similar networks.)

6.6.2. Test Setup

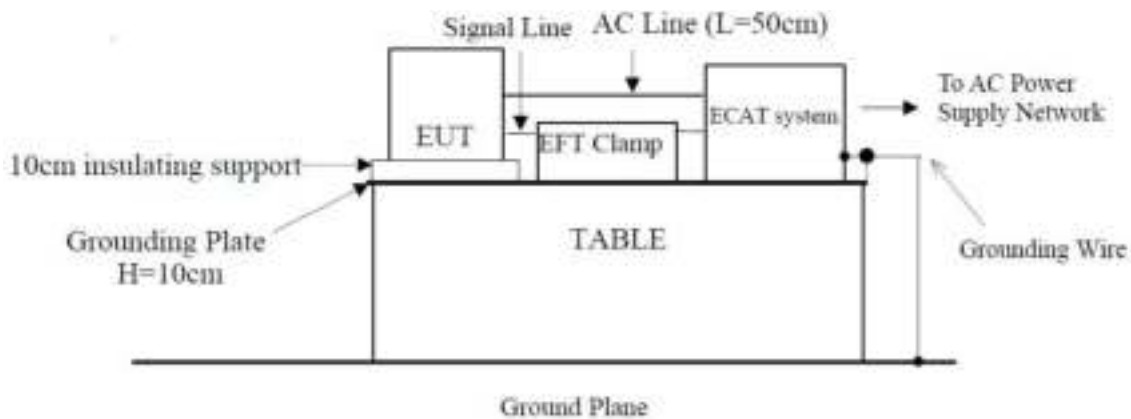

6.6.3. Test Result

Not applicable (EUT Power supply by USB 5V)

6.7 Surges

6.7.1. Test Procedures

- a) For line-to-line coupling mode, provide a 1kV 1.2/50us voltage surge (at open-circuit condition) and 8/20us current surge to EUT selected points, and for active line / neutral lines to ground are same except test level is 2kV.
- b) At least 5 positive and 5 negative (polarity) tests with a maximum 1/min repetition rate are applied during test.
- c) Different phase angles are done individually.
- d) Record the EUT operating situation during compliance test and decide the EUT immunity criterion for above each test.

6.7.2. Test Setup

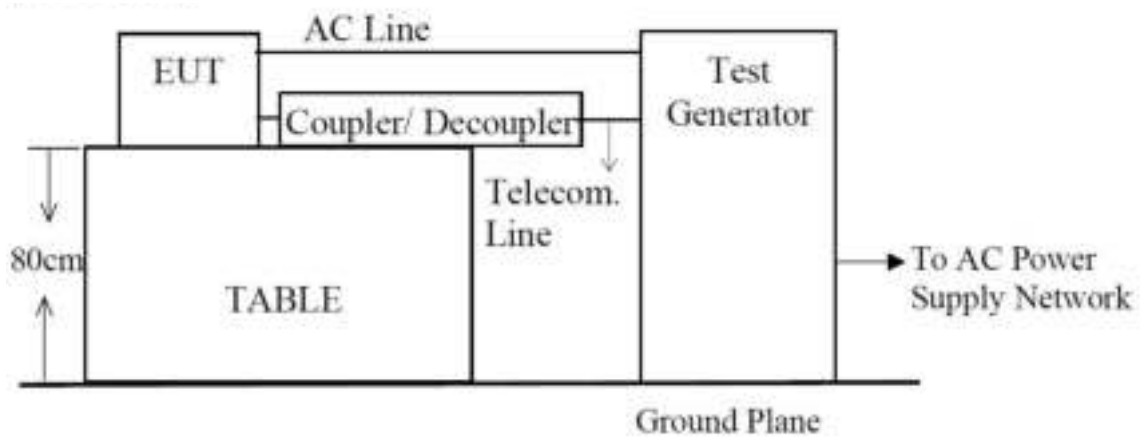

6.7.3. Test Result

Not applicable (EUT Power supply by USB 5V)

6.8 Voltage dips and interruptions

6.8.1. Test procedures

- a) The interruptions are introduced at selected phase angles with specified duration.
- b) Record any degradation of performance

6.8.2. Test setup

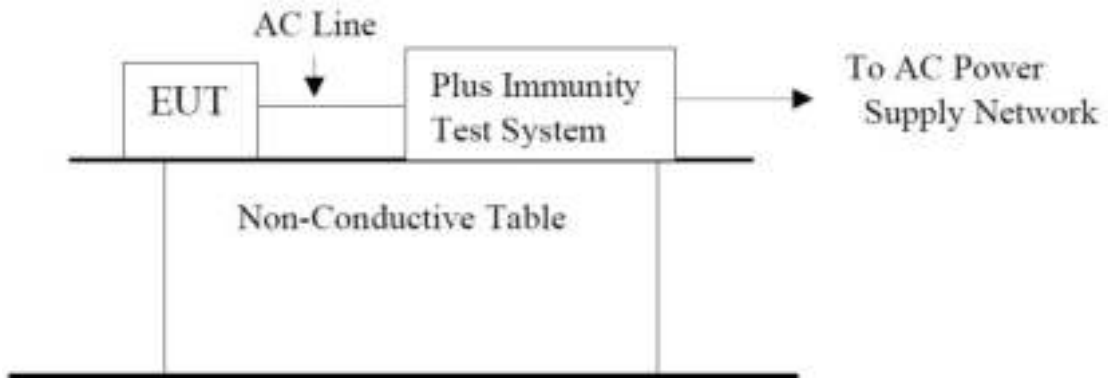

6.8.3. Test result

Not applicable (EUT Power supply by USB 5V)

6.9 Broadband Impulse noise disturbances repetitive

6.9.1. Test procedures

- a) The EUT are placed on an insulating support 0.1m high above a ground reference plane. CDN (coupling and decoupling device) is placed on the ground plane about 0.3m from EUT. Cables between CDN and EUT are as short as possible, and their height above the ground reference plane shall be between 30 and 50 mm (where possible).
- b) The disturbance signal described below is injected to EUT through CDN.
- c) The EUT operates within its operational mode(s) under intended climatic conditions after power on.
- d) The xOSL technology or 30 MHz, whichever is the lowest using 3V signal level, and with the disturbance signal 80% amplitude modulated with a 128 kHz sine wave.
- e) The rate of sweep shall not exceed 1.5×10^{-3} decades/s. Where the frequency is swept incrementally; the step size shall not exceed 1% of the start and thereafter 1% of the preceding frequency value.
- f) Recording the EUT operating situation during compliance testing and decide the EUT immunity criterion.

6.9.2. Test setup

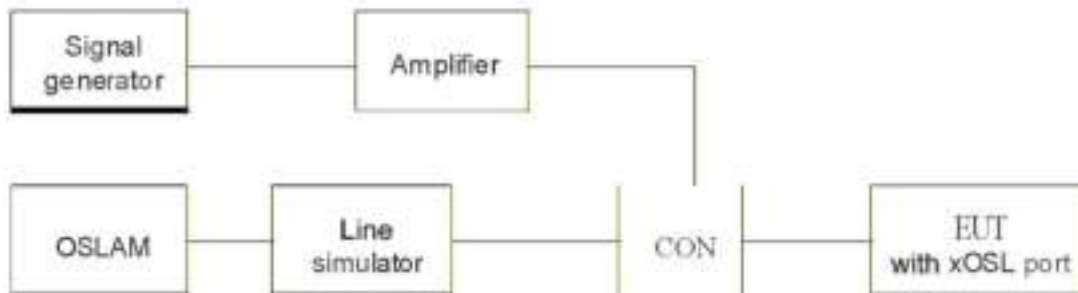

6.9.3. Test result

N/A

6.10 Broadband Impulse noise disturbances isolated

6.10.1. Test procedures

- a) The EUT are placed on an insulating support 0.1m high above a ground reference plane. CDN (coupling and decoupling device) is placed on the ground plane about 0.3m from EUT. Cables between CDN and EUT are as short as possible, and their height above the ground reference plane shall be between 30 and 50 mm (where possible).
- b) The disturbance signal described below is injected to EUT through CDN.
- c) The EUT operates within its operational mode(s) under intended climatic conditions after power on.
- d) The xOSL technology or 30 MHz, whichever is the lowest using 3V signal level, and with the disturbance signal 80% amplitude modulated with a 128 kHz sine wave.
- e) The rate of sweep shall not exceed 1.5×10^{-3} decades/s. Where the frequency is swept incrementally; the step size shall not exceed 1% of the start and thereafter 1% of the preceding frequency value.
- f) Recording the EUT operating situation during compliance testing and decide the EUT immunity criterion.

6.10.2. Test setup

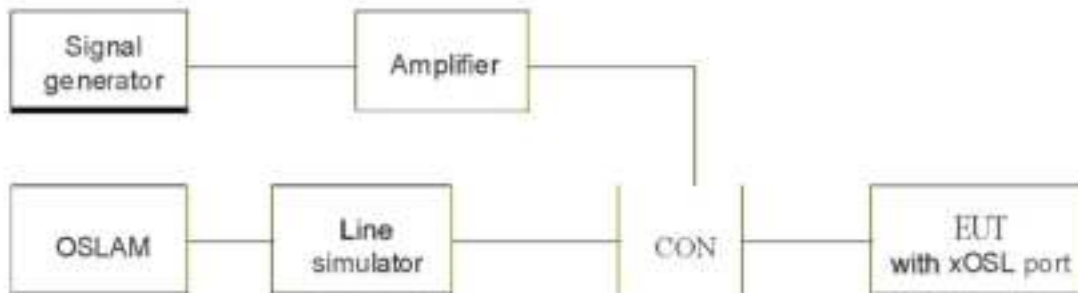

6.10.3. Test result

N/A

Photographs of the test photo

Radiated emission



Conducted emission



Electrostatic discharges



RS

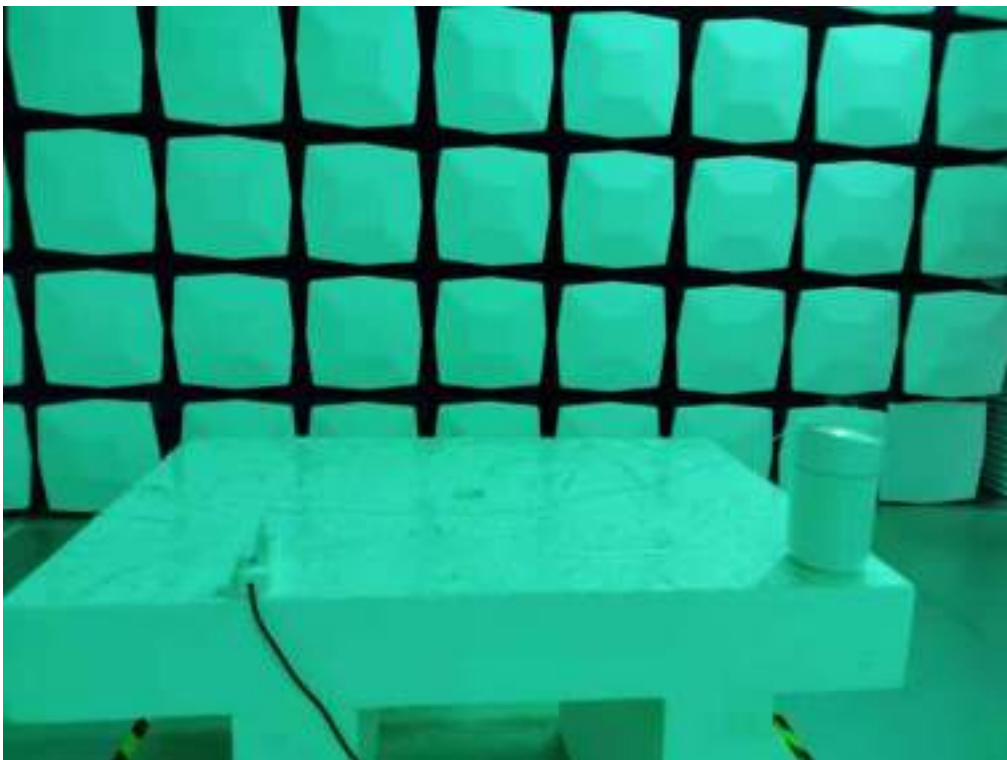

Photographs of the EUT





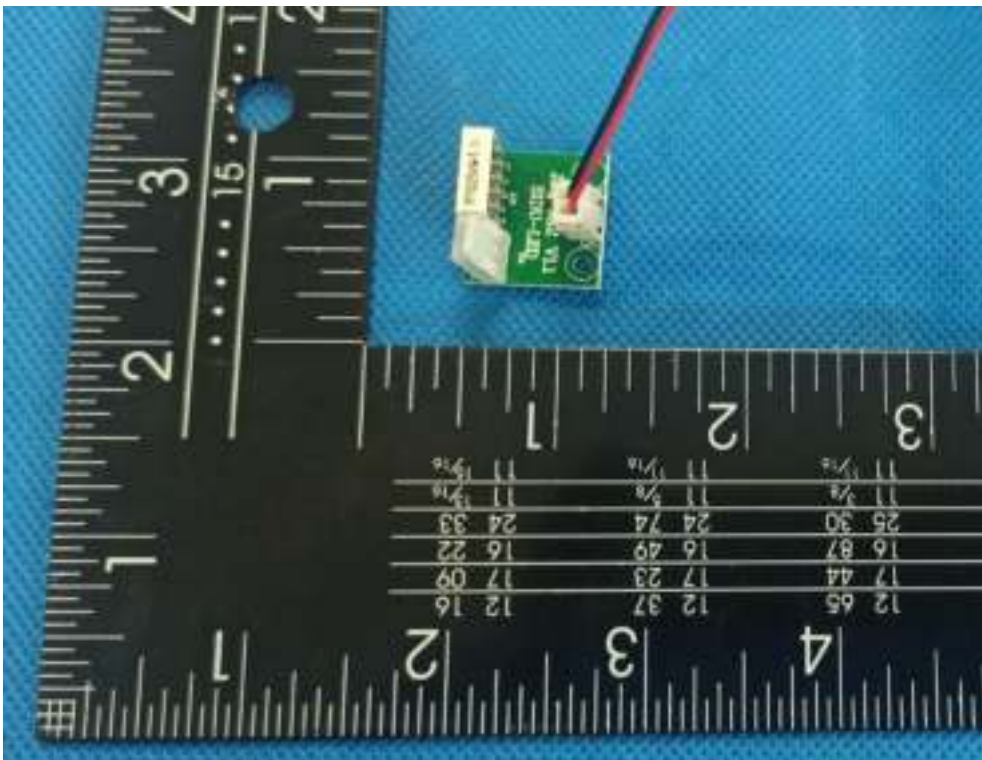
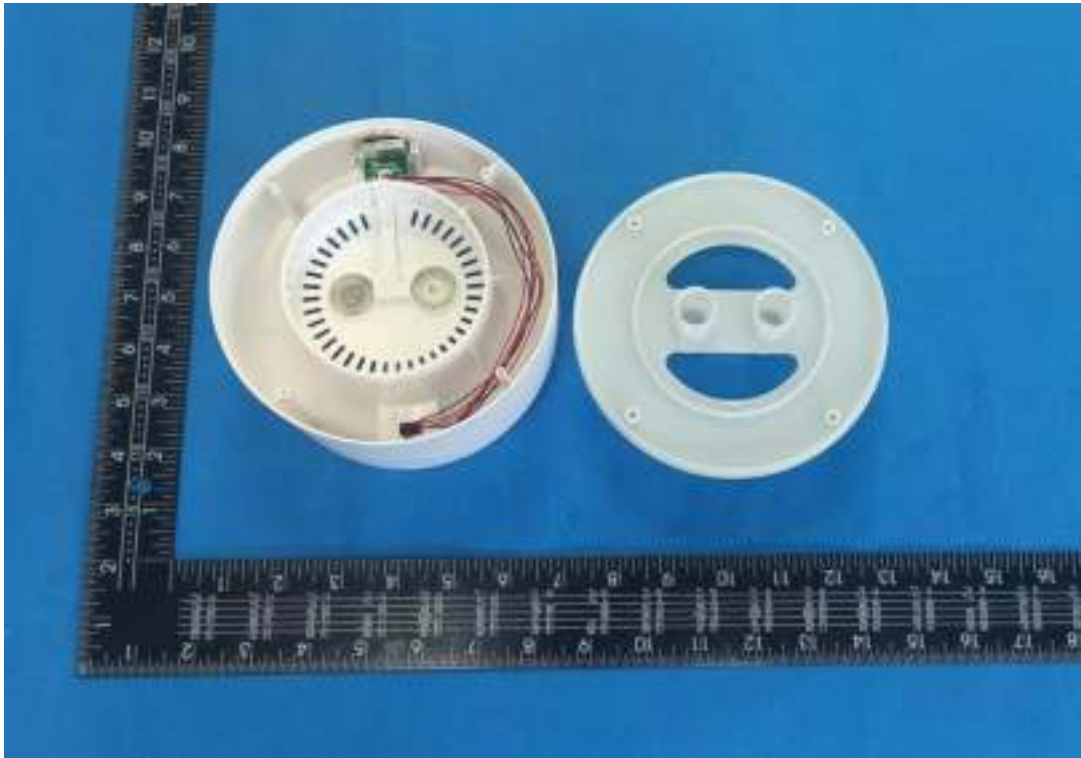

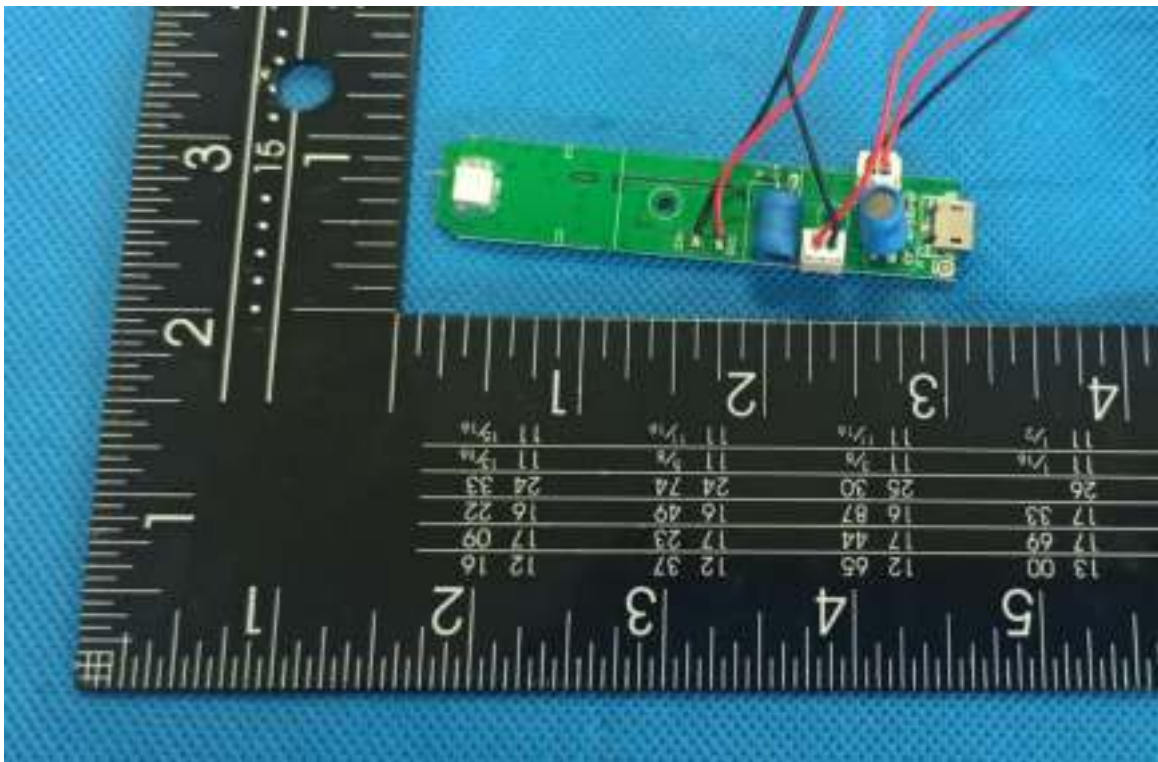
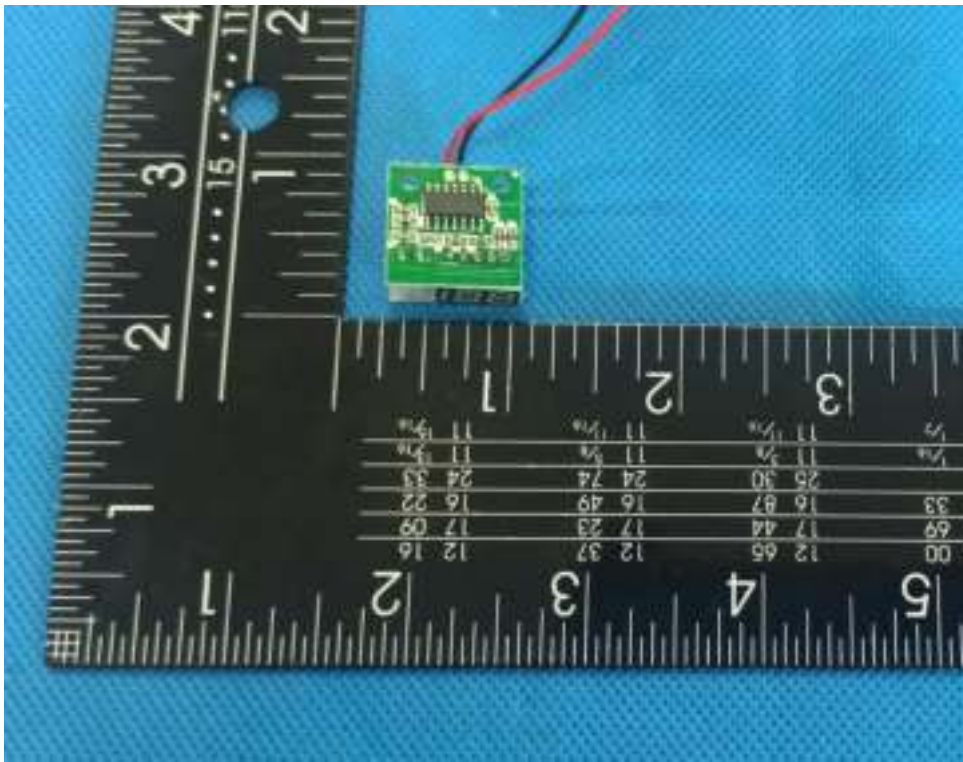

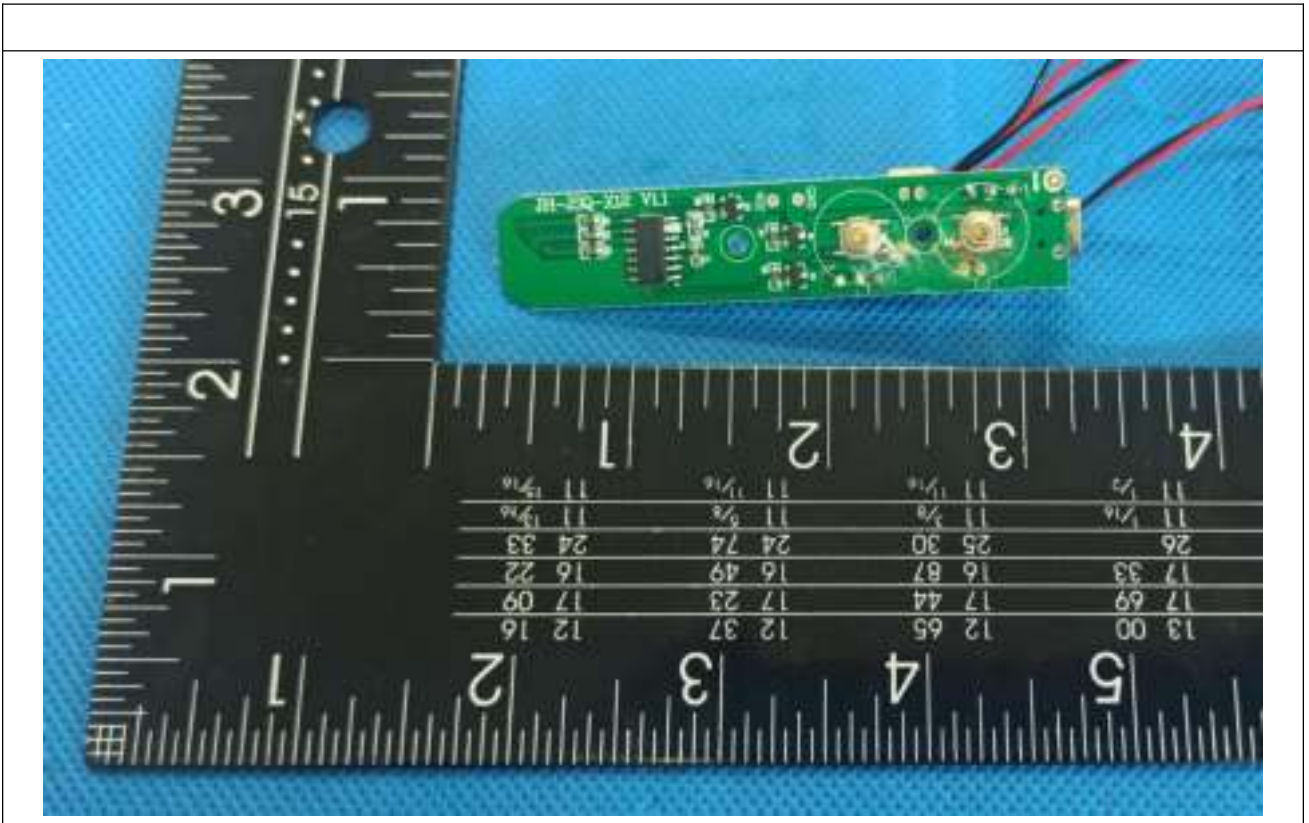

----END OF REPORT----