



INSTRUCTIONS FOR USE
E1 / Phono / BT

Dear Music Lover,

Thank you for choosing Pro-Ject Audio Systems record player.

Your E1 turntable has been handcrafted and rigorously tested by skilled technicians to give you years of enjoyable, trouble free service.

Please contact your dealer if you require additional assistance.

Important:

Your turntable was shipped partially disassembled in order to avoid damage to sensitive parts. Please check immediately to make sure that neither the packaging nor the device was damaged in transit. If you are missing parts or if the unit is damaged, please do not operate and contact your dealer.

Contents

Product illustrations 4

General setup

1. Platter and drive belt installation 5
2. Cartridge installation, stylus exchange 5
3. Vertical Tracking Force setting (VTF) 6
4. Speed control 6
5. Maintenance and cleaning 7
6. Specific turntable informations
 - a) E1 7
 - b) E1 PHONO 8
 - c) E1 BT 9

Technical parameters 10

Troubleshooting, warranty, service 11

Exploded view of the packaging 12

Please do your part to help protect the environment:

Disposal of packaging material:

Pro-Ject packaging is carefully designed to protect your component from damage in transit and you are strongly urged to keep the original packaging in order to safely ship or otherwise transport your turntable in the future.

However, the packaging materials were chosen to be environmentally friendly, so if you must discard the packaging, please recycle.

GENERAL INFORMATIONS

Controls, features and connections

- 1 PLATTER & FELT MAT
- 2 CHASSIS
- 3 MOTOR WITH PULLEY
- 4 SUB – PLATTER
- 5 DRIVE BELT
- 6 TONEARM COUNTERWEIGHT
- 7 TONEARM LIFT LEVER
- 8 TONEARM REST / REMOVABLE TRANSPORT LOCK
- 9 TONEARM TUBE
- 10 HEADSHELL WITH FINGER LIFT AND PRE-MOUNTED ORTOFON CARTRIDGE
- 14 LID
- 13 LID HINGES
- 14 HINGE FASTENERS
- 15 POWER SUPPLY SOCKET
- 16 ON / OFF SWITCH, SPEED SELECTOR

Accessories

- 1 SINGLE ADAPTOR
- 2 ALLEN KEY 2mm
- 3 COUNTERWEIGHT no. 56
- 4 TWO-POINT CARTRIDGE ALIGNMENT PROTRACTOR
- 5 PHONO CABLE
- 6 STYLUS PRESSURE GAUGE
- 7 QUICK SETUP GUIDE

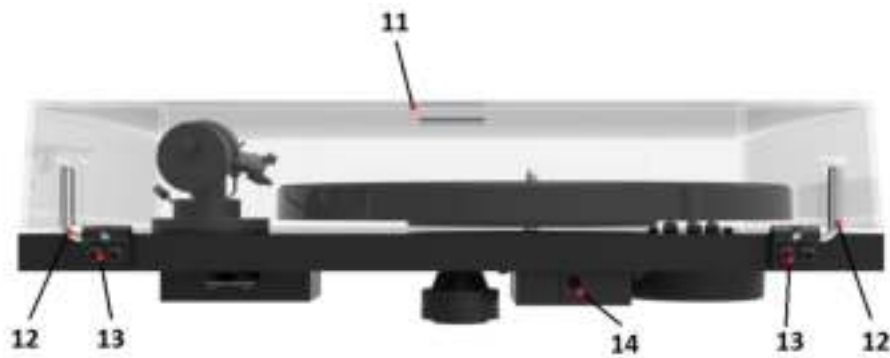
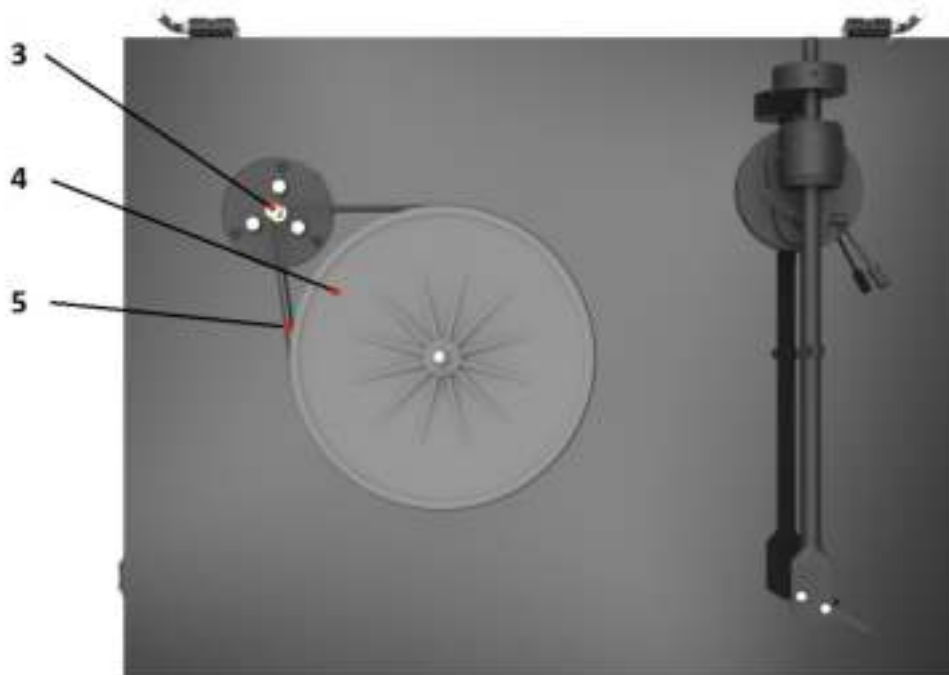
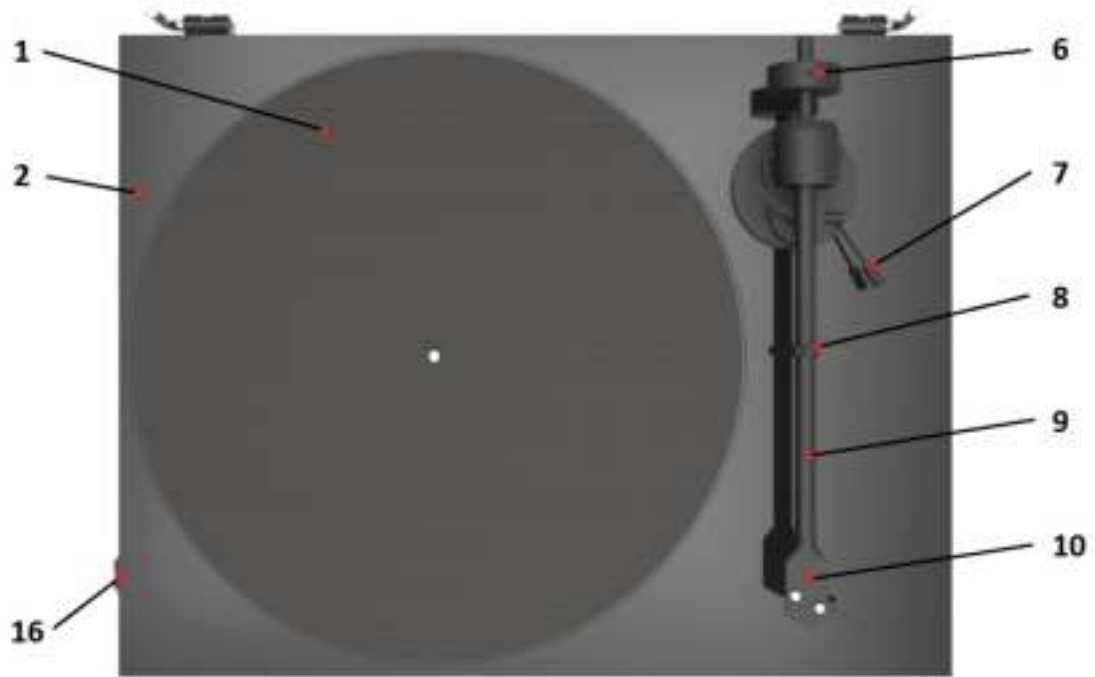

SETUP

1. Platter and drive belt installation

Please remove drive belt from accessories box and install it as shown in the following illustration. Put the felt mat on the top of the platter.

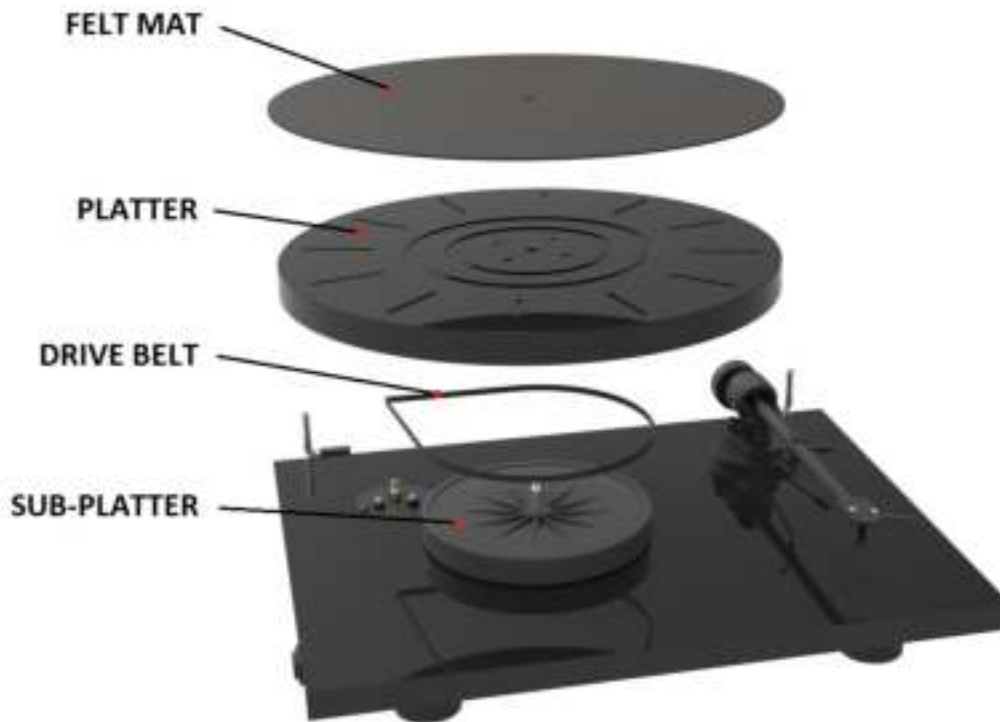

2. Cartridge installation, stylus exchange

* If you purchased this turntable in a package that included the cartridge, this has already been done for you.

Install the cartridge into the headshell, using the appropriate hardware included with your cartridge. All cartridges with half inch mounting holes can be fitted.

Connect the cartridge as indicated below:

- White left channel L+
- Red right channel R+
- Green right channel R-
- Blue left channel L-

For correct cartridge alignment, use the two-point cartridge alignment protractor provided with your Primary DC accessories. If unfamiliar with two-point setup, please refer to your dealer.

A damaged or worn stylus may harm your record collection and should be replaced.

Please remove stylus protection before pulling the stylus from the cartridge and replace for a new one. Stylus type is exchange for pre-mounted cartridge Ortofon OM 5E: Stylus OM 5E. If in doubt, consult your local dealer or distributor.

3. Vertical Tracking Force setting (VTF)

* This setting is only necessary when you decided to replace your cartridge. For factory fitted cartridge, VTF was perfectly pre-set already.

Before setting the Vertical Tracking Force, confirm the exact weight of your cartridge.

Pushing carefully, move the counterweight onto the rear end of the counterweight support rod. Place the stylus pressure gauge onto the platter. To set the required VTF, lower the tonearm lift lever as indicated in the illustration and place the tip of the stylus exactly in between the two points marked 15mN and 20mN. If the stylus gauge becomes level, then the correct pressure has been achieved. However, if there is insufficient or excessive pressure the gauge will either not move or tilt down. Moving the counterweight (6) away from the cartridge will reduce pressure and towards will increase pressure. Finally secure the counterweight (6) using hexagonal key provided.

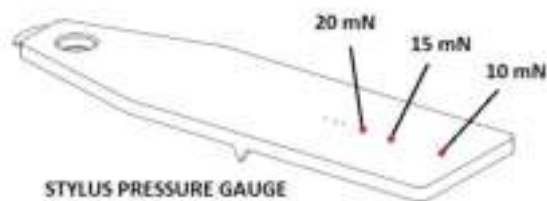

4. Speed control

The turntable is equipped with a three-position switch for ON/OFF and electronic speed change. To play records at 33 r.p.m. press the switch (16) to the front side to position no. 1. To play records at 45 r.p.m. press the switch (16) to the rear side to position no. 2



5. Maintenance and cleaning

Your record player requires little or no regular maintenance. Remove dust with a slightly moistened antistatic cloth. Never use a dry cloth because this will create static electricity which attract more dust! Antistatic cleaning fluids are available at specialist stores but must be applied sparingly to avoid damage to rubber parts. It is recommended to fit the needle cover before cleaning or maintenance is carried out to avoid damage.

If the player is not used over a long period of time the drive belt can be removed to prevent unequal stretching.

E1

SPECIFIC INFORMATIONS

Controls, features and connections

- 1 PHONO OUTPUT CABLE
- 2 POWER SUPPLY SOCKET



Connection to the amplifier

The record player has a captive tonearm signal lead for connection to the amplifier. Use the Phono input on your amplifier. Make sure that the phono input offers correct matching and amplification for the type of cartridge used. Line inputs (such as CD, Tuner, Tape or Video) are not suitable.

Take care to connect the left and right channels correctly. The right channel is usually marked red, the left channel black or white. Check the manual supplied with your amplifier for relevant information. The earthing wire of the tonearm lead should be connected to the earth terminal on your amplifier (if provided).

If your amplifier does not have an input suitable for phono cartridges, you will require a separate phono amplifier stage for MM or MC cartridges which is then connected between the record player and a free line level input of the amplifier.

E1 Phono

SPECIFIC INFORMATION

Controls, features and connections

- 1 PHONO/LINE OUTPUT, EARTH CONNECTION
 - 2 PHONO/LINE OUTPUT SWITCH
 - 3 POWER SUPPLY SOCKET
-



Connection to the amplifier

The record player has gold plated female RCA phono sockets and possibility to choose between Phono and LINE output. With LINE OUT on, you can use a line input (such as AUX, CD, Tuner, Tape or Video) on your amplifier. With PHONO OUT on, you can use your own phono pre-amplifier (sometimes labelled gram, disc or RIAA).



Take care to connect the left and right channels correctly. The right channel is usually marked red, the left channel black or white. The earthing wire of the tonearm lead should be connected to the earth terminal on your amplifier (if provided).

Controls, features and connections

- 1 PHONO/LINE OUTPUT, EARTH CONNECTION
- 2 BLUETOOTH SWITCH

**Connection to the amplifier**

The record player has two possible outputs – Line OUT with integrated preamplifier and Phono OUT for connection to the preamplifier. If you choose Phono OUT, then use the Phono input (sometimes labelled gram, disc or RIAA) on your amplifier. Make sure that the phono input offers correct matching and amplification for the type of cartridge used. If you choose Line OUT, then use the Line inputs (like CD, Tuner, Tape or Video).

Take care about connecting the left and right channel correctly. The right channel is usually marked red, the left channel black or white. Check the manual of your amplifier for relevant information. An earthing wire may be connected to the screw terminal between the sockets if you encounter humming problems.

Bluetooth pairing

The record player has Bluetooth output and transmit signal automatically when is connected to mains.

It is paired automatically with any device with Bluetooth receiver (such as Pro-Ject MaiA, MaiA DS, Bluetooth Box S and Bluetooth Box E).

For pairing with other devices and portable speakers use the manual of the given product.

For restart of the Bluetooth transmitter, please turn OFF and ON the Bluetooth module by using the switch. Restart is needed only when there is a change of the Bluetooth receiver.

Technical specifications Pro-Ject E1 / Pro-Ject 8.6

Nominal speeds	33/45 r.p.m.
Speed variance	33: $\pm 0.70\%$ 45: $\pm 0.60\%$
Wow and flutter	33: $\pm 0.25\%$ 45: $\pm 0.23\%$
Signal to noise	-65dB
Effective tonearm mass	7.0g
Effective tonearm length	8.6" (218.5mm)
Overhang	22,0mm
Power consumption	4.5W
Outboard power supply	15V / 0 – 0.8A DC (set at 0.5A), universal power supply
Dimensions (W x H x D)	420 x 112 x 330mm, with open dustcover 420 x 370 x 393mm
Weight	3.5 kg
Dimensions packaging (W x H x D)	488 x 235 x 393mm
Weight incl. packaging	5.5kg

Technical specifications MM-Cartridge Ortofon OM 5E

Frequency range	20-25.000Hz
Channel separation	22dB/1kHz
Output voltage	4mV
Recommended load impedance	47kohms/amplifier connection – MM-input
Compliance/stylus type	20 μ m/mN – elliptical
Recommended tracking force	17.5mN
Weight	5g

Technical specifications MM phono pre-amplifier

Gain	34dB
Output voltage typically	200mV/1kHz at 5mV/1kHz input
Input impedance	47kohms/100pF
Noise floor	-68dB
RIAA-equalisation curve accuracy	20Hz-20kHz / max. 0.5dB

Bluetooth

Maximum transmit power per operated frequency band	Class II, 2.5mW (4dBm) per 2.4GHz – 2.48 GHz
--	--

Potential incorrect use and fault conditions

Pro-Ject turntables are manufactured to the highest standards and undergo strict quality controls before leaving the factory. Faults that may possibly occur are not necessarily due to material or production faults but can sometimes be caused by incorrect use or unfortunate circumstances. Therefore the following list of common fault symptoms is included.

The platter doesn't turn although the unit is switched on:

- The unit is not connected to the mains power supply.
- No mains at the socket.
- Drive belt is not fitted or has slipped off.

No signal through one or other channel or both channels:

- No signal contact from the cartridge to the internal tonearm wiring or from that to the arm lead or from that to the phono box or between that and the amplifier. This could be due to a faulty plug, broken wire or solder joint or simply loose plug/socket connection.
- Phono input not selected at amplifier.
- Amplifier is not switched on.
- Amplifier or speakers are defective or muted.
- No connection to the loudspeakers.

Strong hum on phono input:

- No earth connection from cartridge or arm or arm cable to amplifier, or earth loop.

Distorted or inconsistent sound from one or both channels:

- Record player is connected to wrong input of amplifier, or MM/MC switch incorrectly set.
- Needle or cantilever damaged.
- Wrong r.p.m., drive belt overstretched or dirty, platter bearing without oil, dirty or damaged

Service

Should you encounter a problem which you are not able to alleviate or identify despite the above information, please contact your dealer for further advice. Only when the problem cannot be resolved there should the unit be sent to the responsible distributor in your country.

Guarantee repairs will only be affected if the unit is returned correctly packaged. For this reason we recommend keeping the original packaging.

Never return a record player without making sure that it is safely disassembled and correctly packaged in the original packaging according to the diagrams on the last page of this user guide. Please remove these parts and pack them separately: lid, counterweight, anti-skating weight and belt.

Fit the cartridge protection cap and the transport lock for the tonearm tube, prior to carefully packaging the record player.

Warranty



The manufacturer accepts no responsibility for damage caused by not adhering to these instructions for use and/or by transportation without the original packaging. Modification or change to any part of the product by unauthorized persons, release the manufacturer from any liability over and above the lawful rights of the customer.

Pro-Ject Audio Systems is a Registered Trademark of H. Lichtenegger.

This guide was produced by: Pro-Ject Audio Systems
Copyright © 2022. All rights reserved.

The information was correct at the time of going to press. The manufacturer reserves the right to make changes to the technical specification without prior notice as deemed necessary to uphold the ongoing process of technical development.

