

# Montageanleitung | Instructions de montage Assembly Instructions | Instrucciones de montaje

SKU NUMBER: N616P189659/N616P189660  
N616P189661/N616P189662  
N616P189663/N616P189664

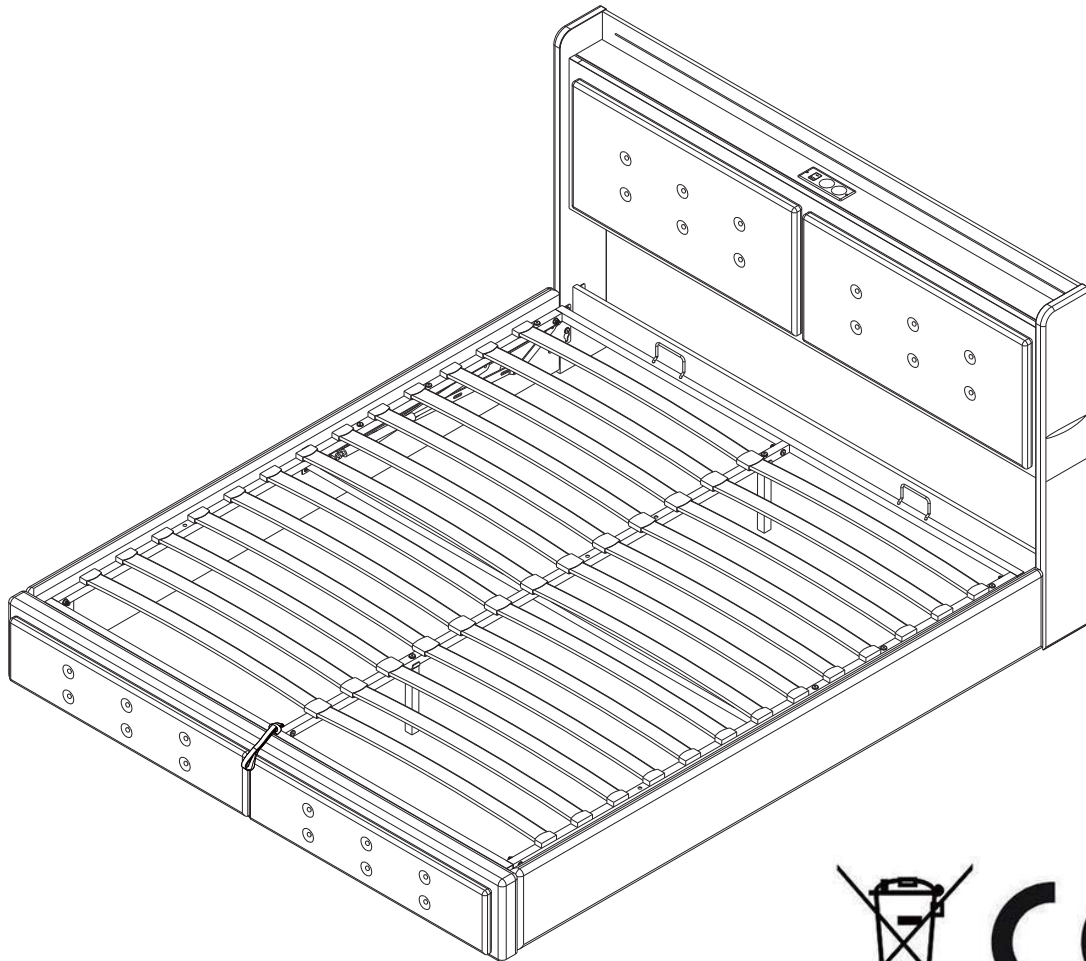

- GB** This set comes in 2 boxes. If you do not receive a full set of 2 boxes, please contact our customer service.
- DE** Dieses Set wird in 2 Schachteln geliefert. Wenn Sie nicht ein komplettes Set von 2 Boxen erhalten, kontaktieren Sie bitte unseren Kundenservice.
- FR** Ce set est livré en 2 boîtes. Si vous ne recevez pas un jeu complet de 2 boîtes, veuillez contacter notre service clientèle.

## English

### IMPORTANT FOR GAS LIFT BEDS&MAINTAINANCE

- Please place the mattress on top of the bed frame.
- Please do not pull on the strap handles.
- Please press heavily to release the compressed gas.
- Periodically check all screw & fixings to ensure they are secure.
- When moving your product, carefully lift into place.
- Wipe clean with a slightly damp cloth- please do not use abrasive chemicals or bleach.
- Do NOT allow children to operate the lift mechanism.
- Do NOT allow children near the lift base when operating the mechanism.
- Do NOT stand inside the bed or the internal storage base.
- Do NOT overload the internal storage base.
- DO NOT jump on the product or any of its parts.

## Deutsch

### WICHTIG FÜR GASLIFT-BETTEN&WARTUNG

- Bitte legen Sie die Matratze oben auf den Bettrahmen.
- Bitte ziehen Sie nicht an den Gurtgriffen.
- Bitte drücken Sie kräftig, um das komprimierte Gas freizusetzen.
- Überprüfen Sie regelmäßig alle Schrauben und Befestigungen, um sicherzustellen, dass sie sicher sind.
- Wenn Sie Ihr Produkt bewegen, heben Sie es vorsichtig an seinen Platz.
- Mit einem leicht feuchten Tuch abwischen - bitte keine scheuernden Chemikalien oder Bleichmittel verwenden.
- Erlauben Sie Kindern NICHT, den Hebemechanismus zu bedienen.
- Lassen Sie Kinder NICHT in die Nähe des Liftsockels, wenn Sie den Mechanismus bedienen.
- Stellen Sie sich NICHT in das Bett oder in die Innenablage.
- Überlasten Sie den internen Liftsockel NICHT.
- Springen Sie NICHT auf das Produkt oder eines seiner Teile.

## Français

### IMPORTANT POUR LES LITS À RELEVAGE DE GAZ&MAINTENANCE

- Veuillez placer le matelas sur le dessus du cadre de lit.
- Ne tirez pas sur les poignées de la sangle.
- Appuyez fortement pour libérer le gaz comprimé.
- Vérifiez régulièrement que toutes les vis et fixations sont bien en place.
- Lorsque vous déplacez votre produit, soulevez-le avec précaution pour le mettre en place.
- Nettoyez avec un chiffon légèrement humide - n'utilisez pas de produits chimiques abrasifs ou d'eau de Javel.
- Ne laissez pas les enfants utiliser le mécanisme de levage.
- Ne laissez pas les enfants s'approcher de la base de levage lorsqu'ils actionnent le mécanisme.
- Ne vous tenez PAS à l'intérieur du lit ou de la base de stockage interne.
- Ne surchargez pas la base de stockage interne.
- Ne pas sauter sur le produit ou l'une de ses parties.

## Italiano

### IMPORTANTE PER I LETTI CON SOLLEVAMENTO A GAS E LA MANUTENZIONE

- Posizionare il materasso sopra la struttura del letto.
- Non tirare le maniglie della cinghia.
- Premere con forza per rilasciare il gas compresso.
- Controllare periodicamente tutte le viti e i fissaggi per assicurarsi che siano saldi.
- Quando si sposta il prodotto, sollevarlo con cautela.
- Pulire con un panno leggermente umido, senza usare prodotti chimici abrasivi o candeggina.
- NON permettere ai bambini di azionare il meccanismo di sollevamento.
- NON permettere ai bambini di avvicinarsi alla base di sollevamento quando si aziona il meccanismo.
- NON sostare all'interno del letto o della base di contenimento interna.
- NON sovraccaricare la base di contenimento interna.
- NON saltare sul prodotto o sulle sue parti.

## Español

### IMPORTANTE PARA LAS CAMAS ELEVADORAS DE GAS&MANTENIMIENTO

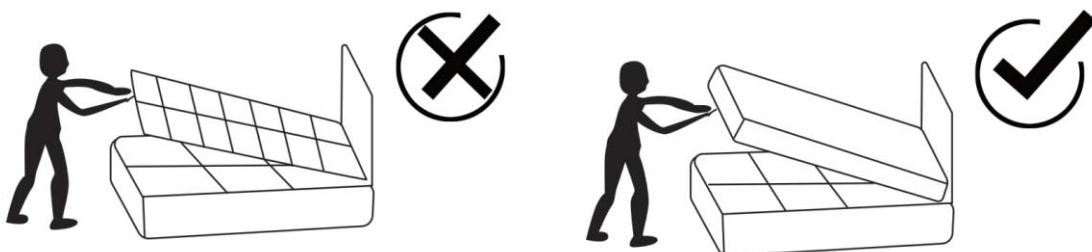

- Coloque el colchón sobre el somier.
- No tire de las asas de la correa.
- Presione con fuerza para liberar el gas comprimido.
- Compruebe periódicamente que todos los tornillos y fijaciones estén bien sujetos.
- Al mover el producto, levántelo con cuidado para colocarlo en su sitio.
- Limpie con un paño ligeramente humedecido; no utilice productos químicos abrasivos ni lejía.
- NO permita que los niños accionen el mecanismo de elevación.
- NO permita que los niños se acerquen a la base elevadora cuando accionen el mecanismo.
- NO se ponga de pie dentro de la cama o de la base de almacenamiento interna.
- NO sobrecargue el somier.
- NO salte sobre el producto ni sobre ninguna de sus piezas.

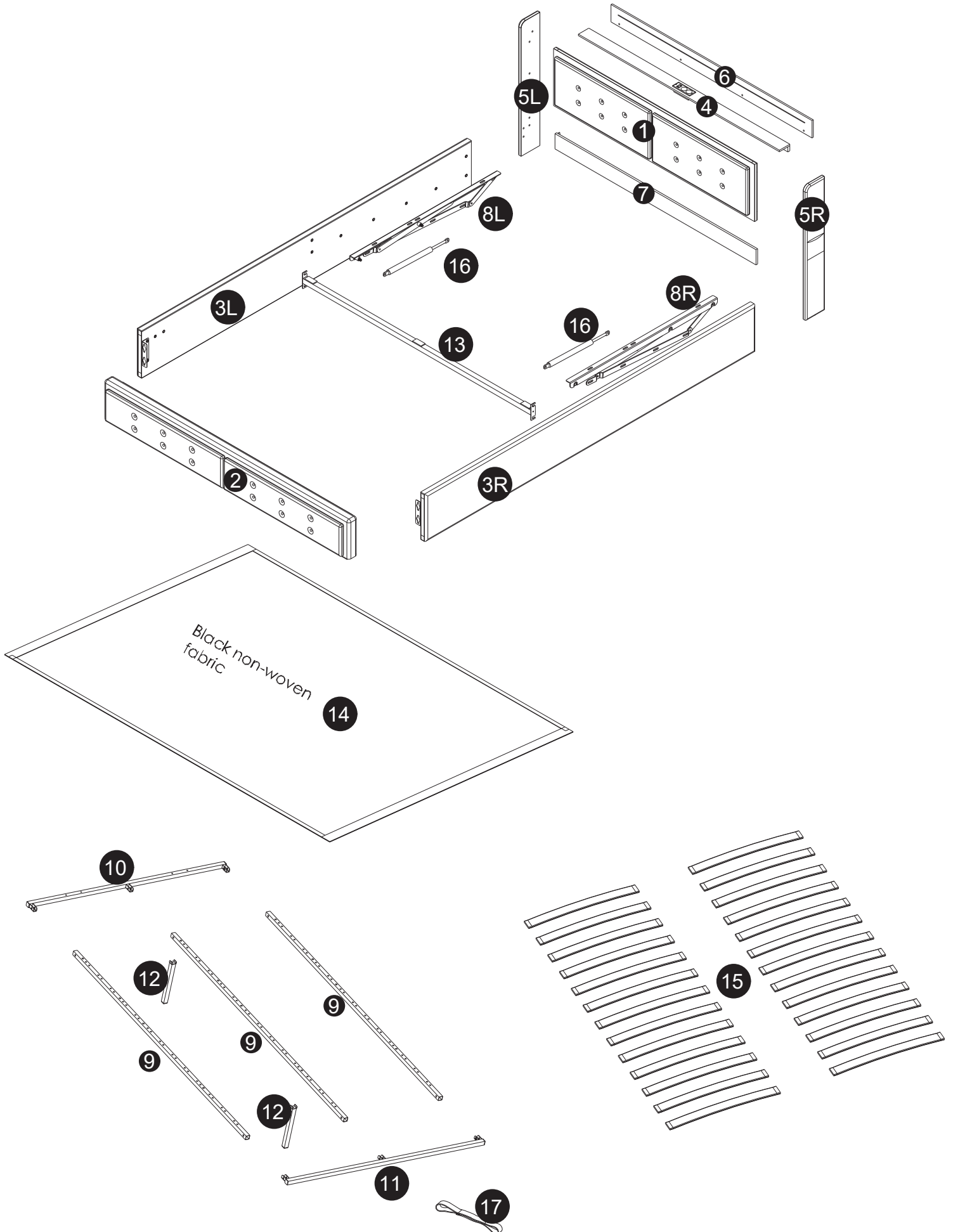

# Stückliste



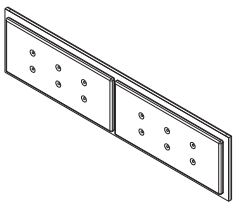
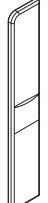
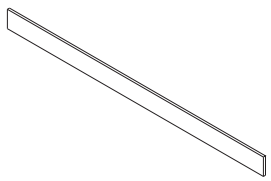
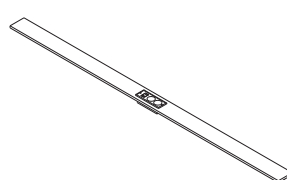
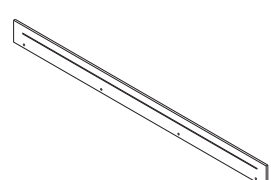
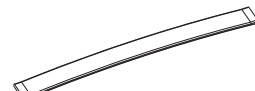





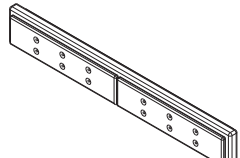
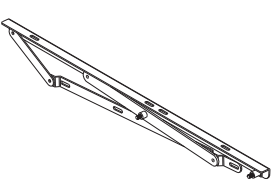
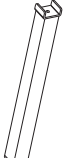
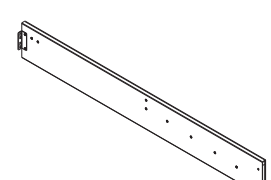
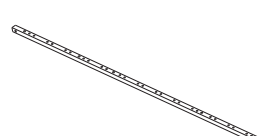
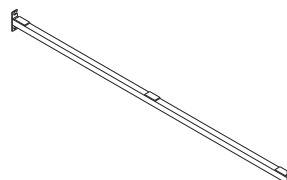
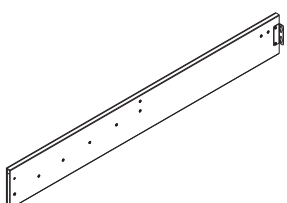
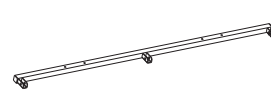
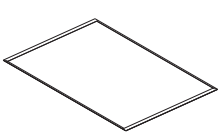
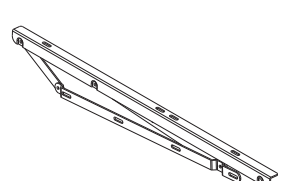
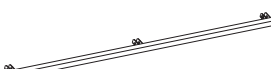
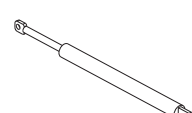
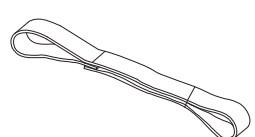



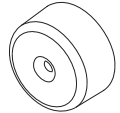

# N616P189659/N616P189661/N616P189663

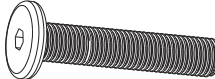
1		X1	5R		X1	7		X1
4		X1	6		X1	15		X26
5L		X1						

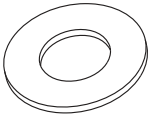
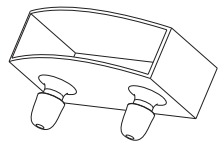
# N616P189660/N616P189662/N616P189664

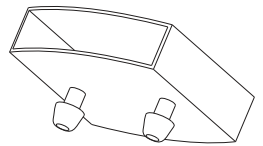
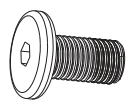
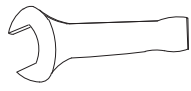
2		X1	8R		X1	12		X2
3L		X1	9		X3	13		X1
3R		X1	10		X1	14		X1
8L		X1	11		X1	16		X2
						17		X1

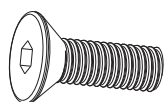
## Hardware List-Hardware-Liste-Liste du matériel N616P189659/N616P189661/N616P189663

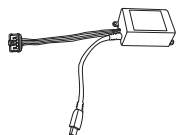
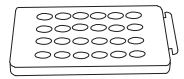
<b>A</b>		X1	<b>G</b>	 M8x30mm	X12	<b>Q</b>		x2
<b>B</b>	 M4x40mm	X2	<b>H</b>	 M8x40mm	X12	<b>S</b>		x8
<b>C</b>	 M6 x 35mm	X2	<b>J</b>		X12	<b>U</b>		x26
<b>D</b>	 M8x16mm	X6	<b>K</b>	 M8	X16	<b>V</b>		x13
<b>E</b>	 M8x20mm	X44	<b>L</b>		X1	<b>X</b>		x1
<b>F</b>	 M8x18mm	X4	<b>M</b>		x10	<b>Y</b>		x1
						<b>Z</b>		x1

## Hardware List-Hardware-Liste-Liste du matériel N616P189660/N616P189662/N616P189664

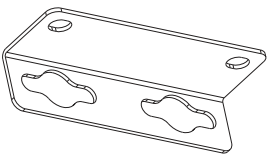
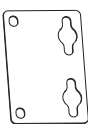
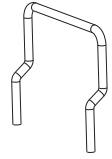
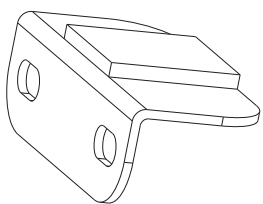
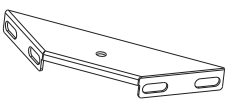
<b>N</b>		x2	<b>R</b>		x2	<b>W</b>		x2
<b>P</b>		x1	<b>T</b>	 06/21	x2			

**1**

A x 1



D x 6



M8 x 16mm

M x 6

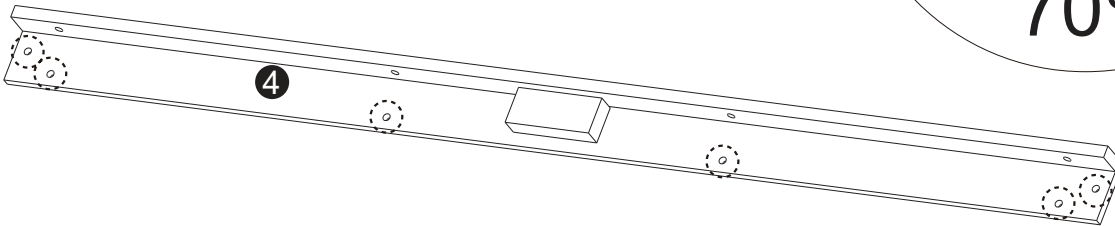
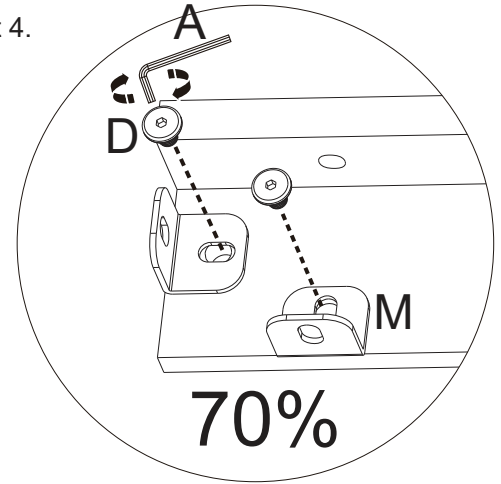

The bottom of the iron sheet needs to be flush with the edge of the part 4.  
 Le fond de la tôle doit être affleuré avec le bord de la partie 4.  
 Das blech muß mit der kante Von teil 4 ebenert werden.

**2**

A x 1



E x 4



M8 x 20mm

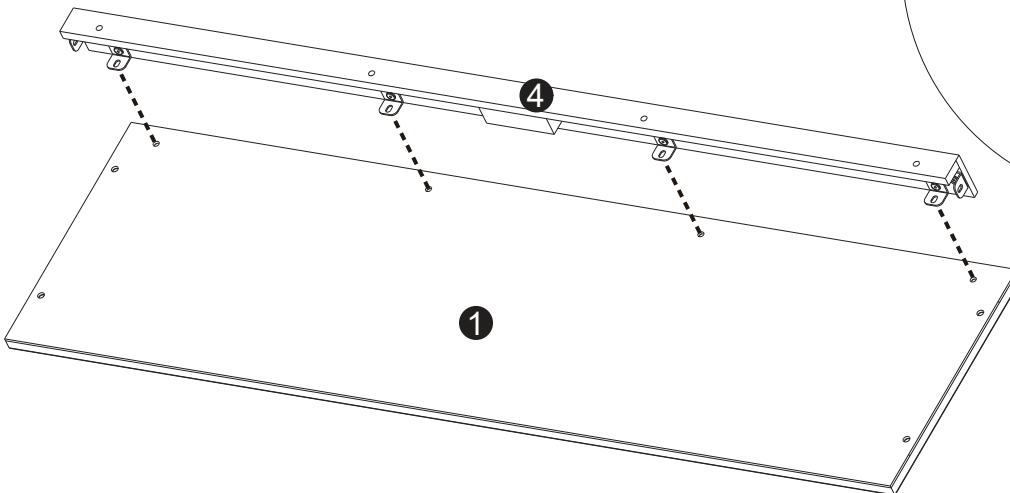
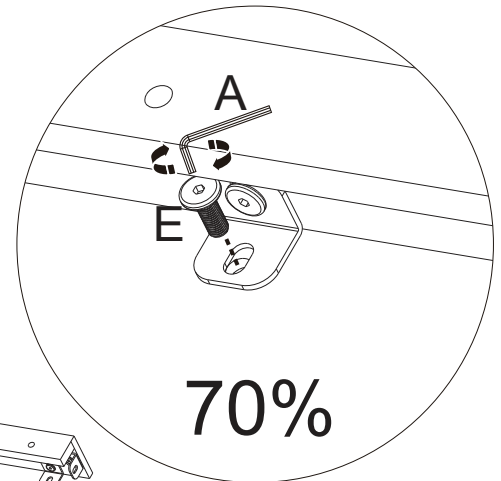

3

A x 1

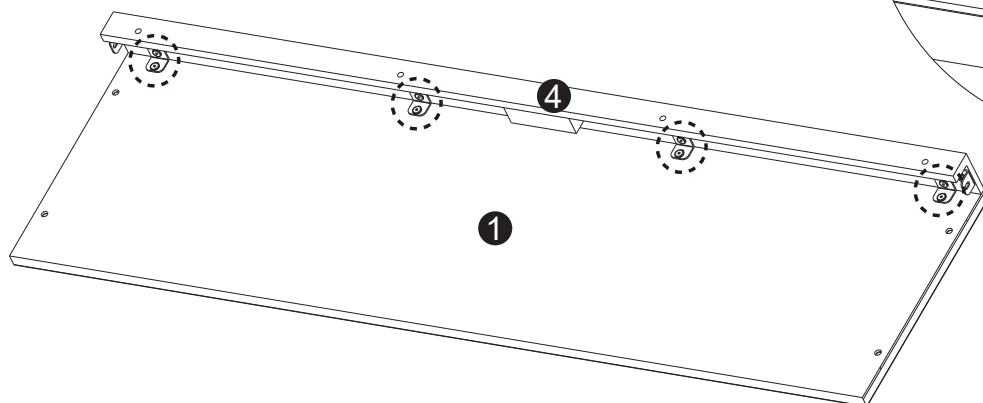
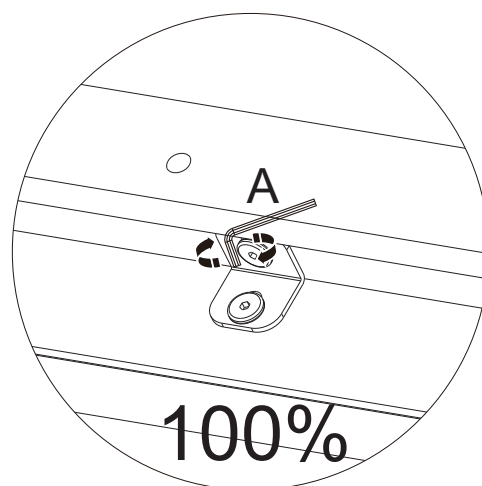

4

A x 1



G x 4



M8 x 30mm

J x 4

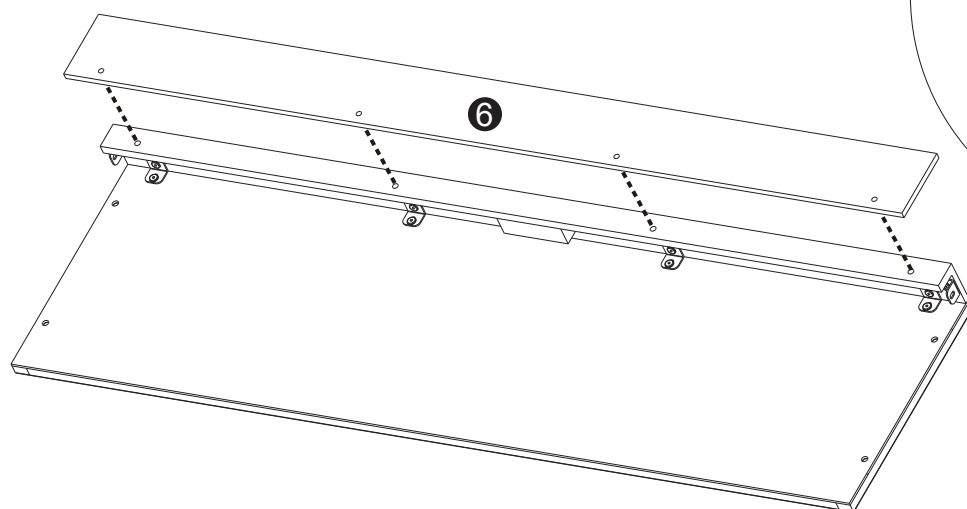
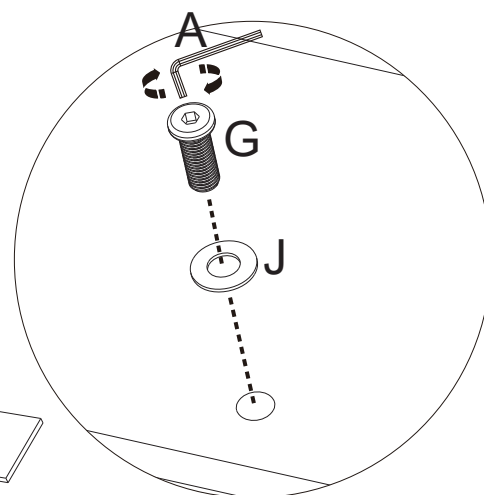

**5**

A x 1



E x 18



M8 x 20mm

M x 4

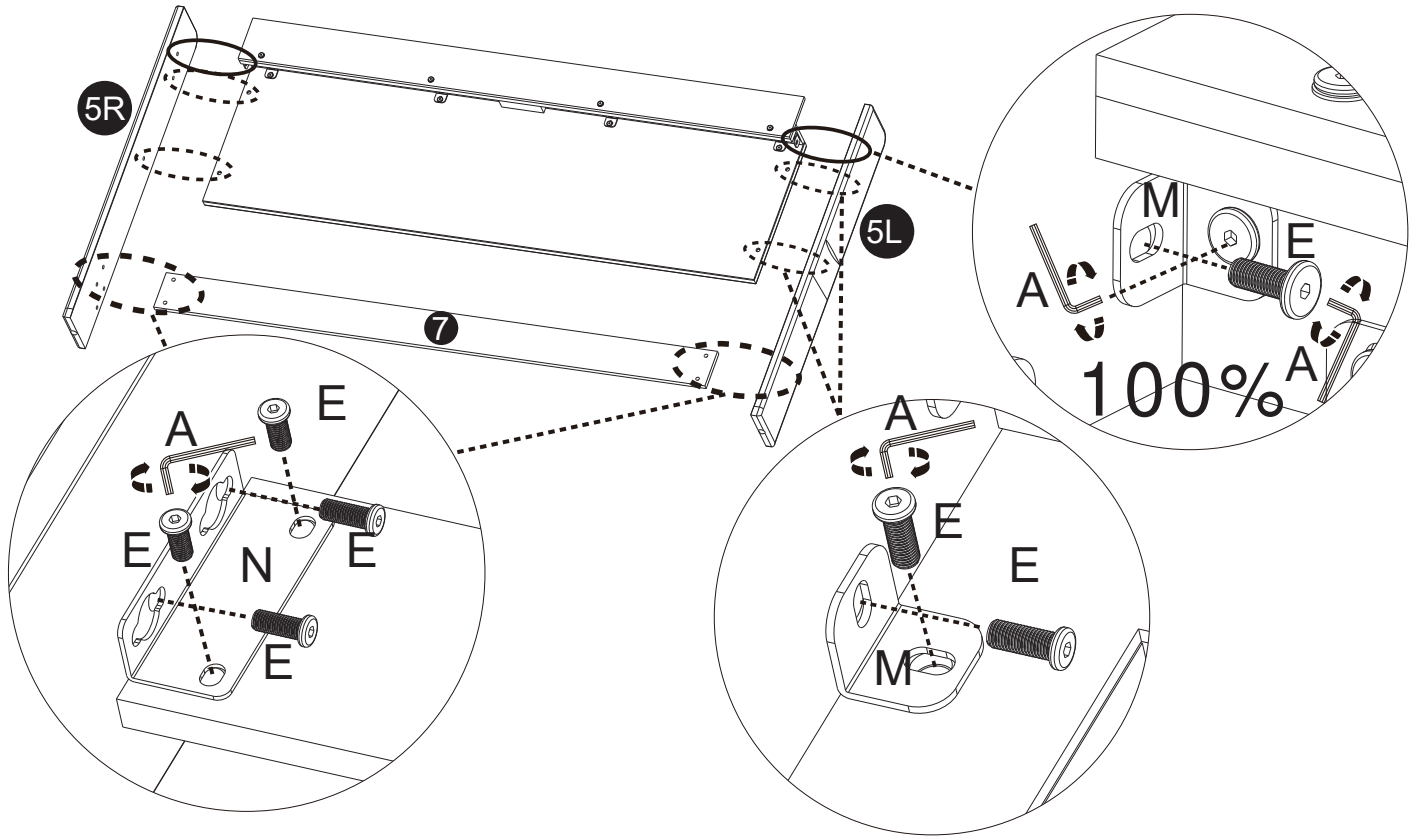
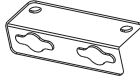

N x 2

**6**

A x 1



B x 2



M4 x 40mm

E x 2



M8 x 20mm

P x 1

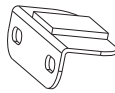

Q x 2

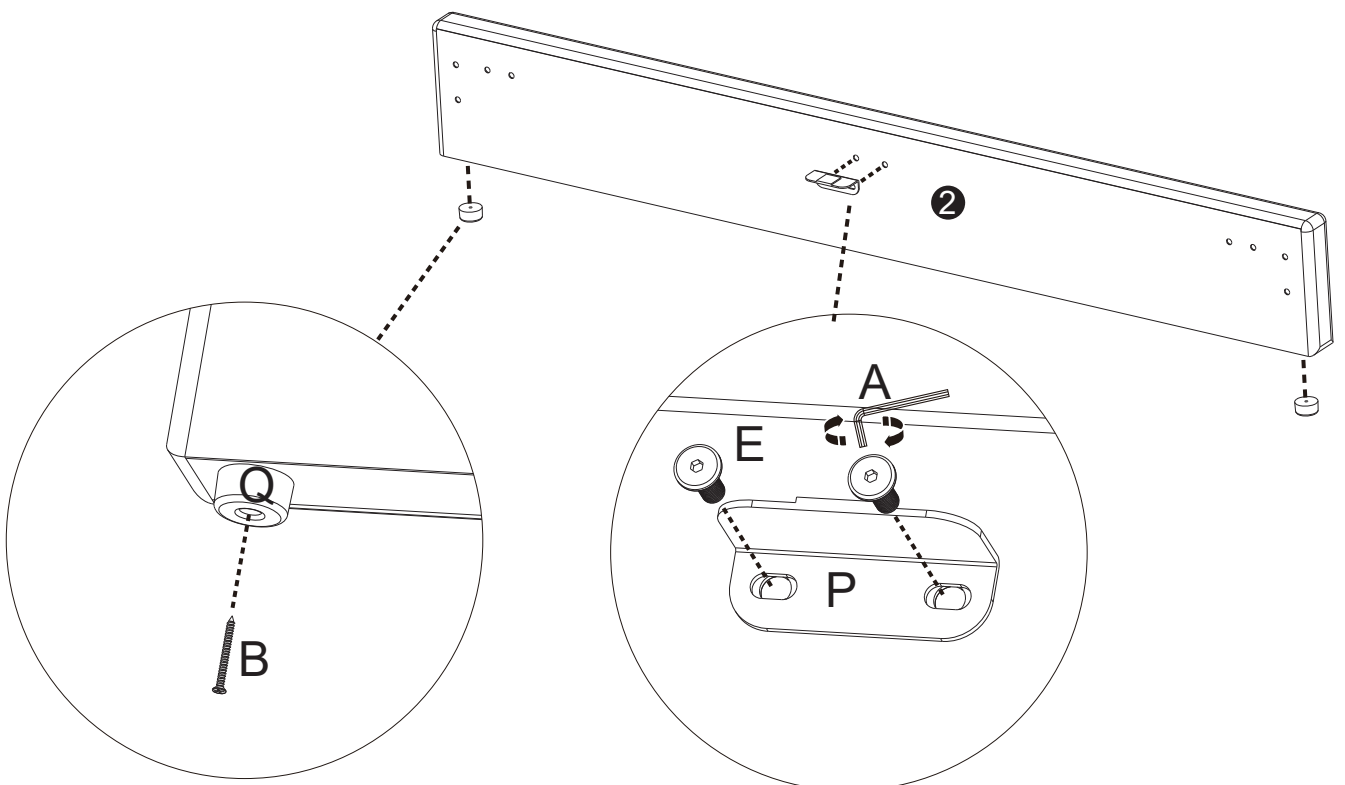

7

A x 1



E x 8



M8 x 20mm

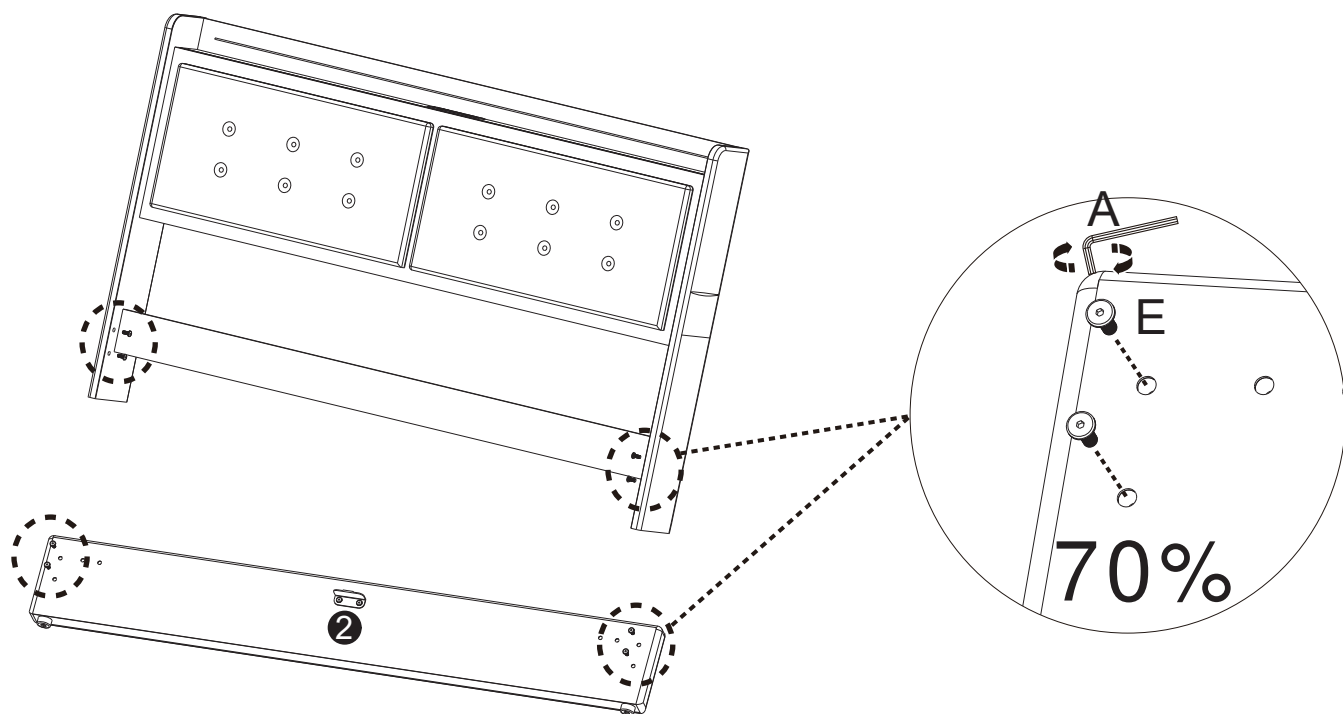

8

A x 1



E x 4



M8 x 20mm

F x 4

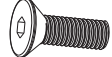

M8 x 18mm

R x 2

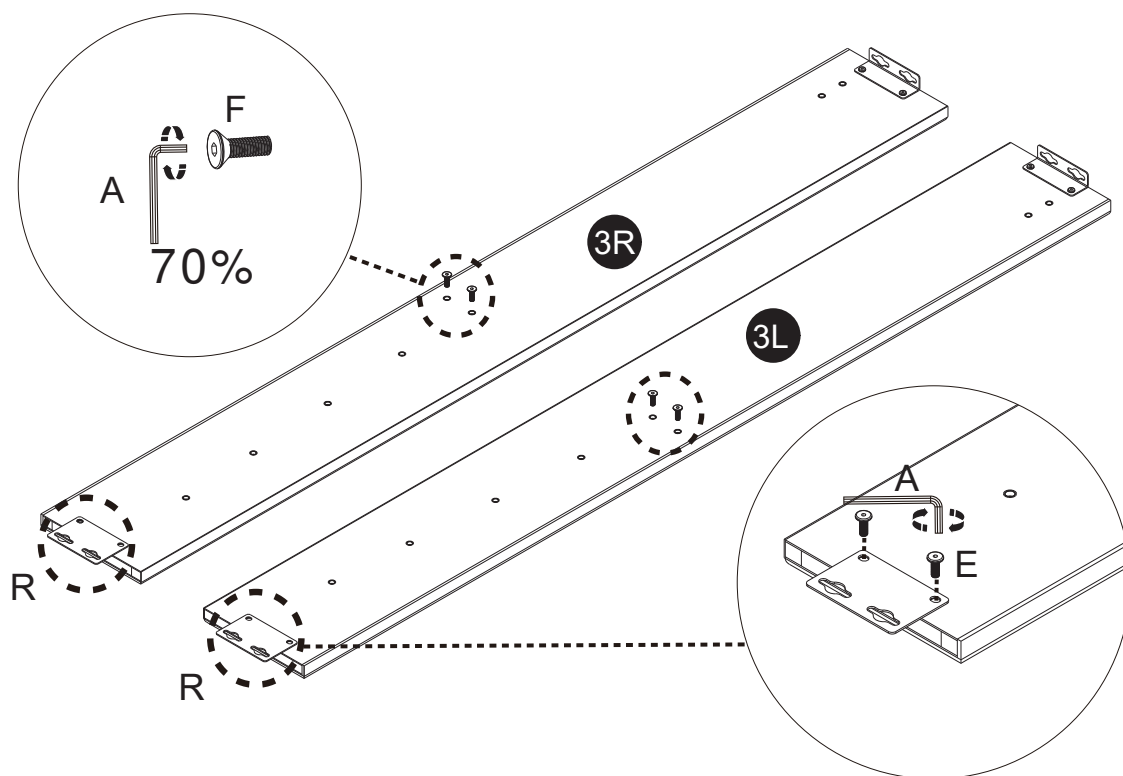

9

A x 1



G x 8



M8 x 30mm

S x 8

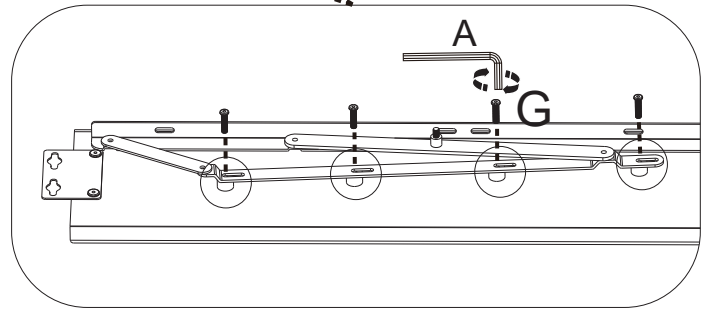
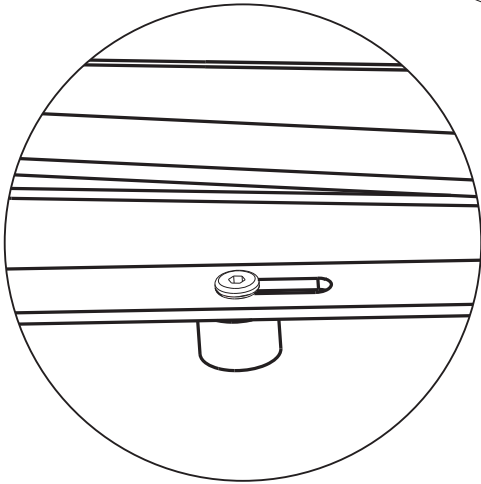
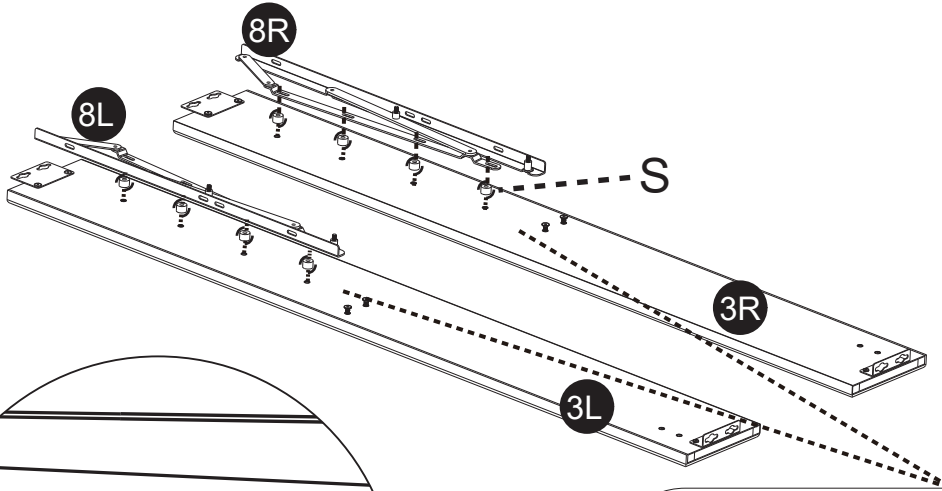

10

A x 1

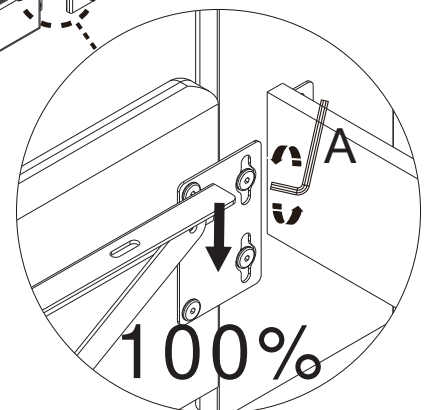
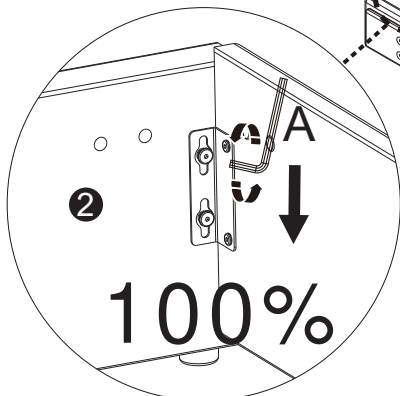
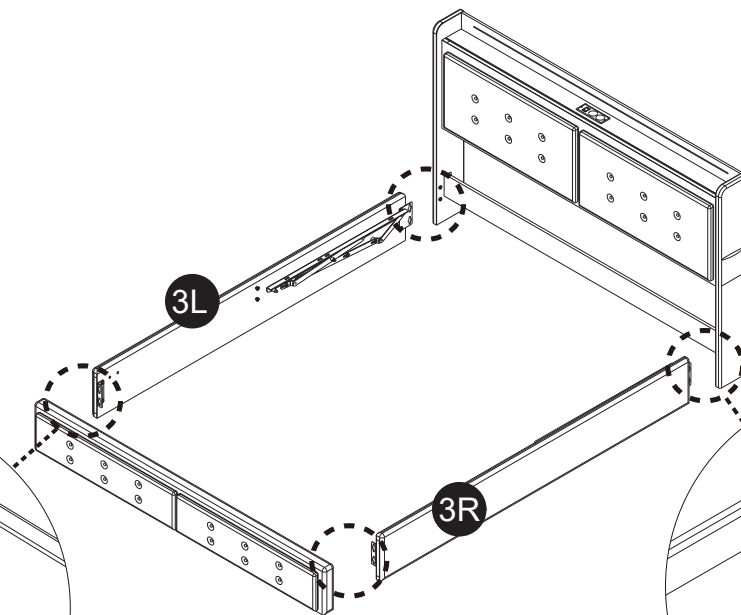

11

A x 1



E x 8



M8 x 20mm

T x 2

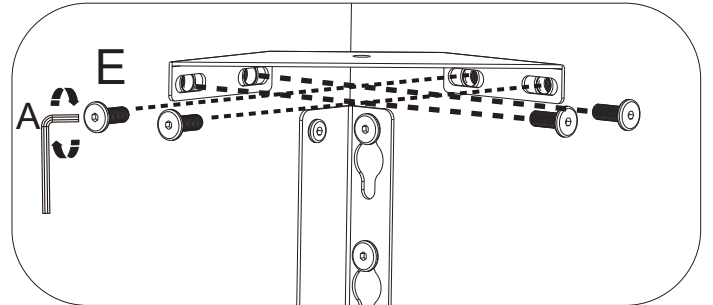
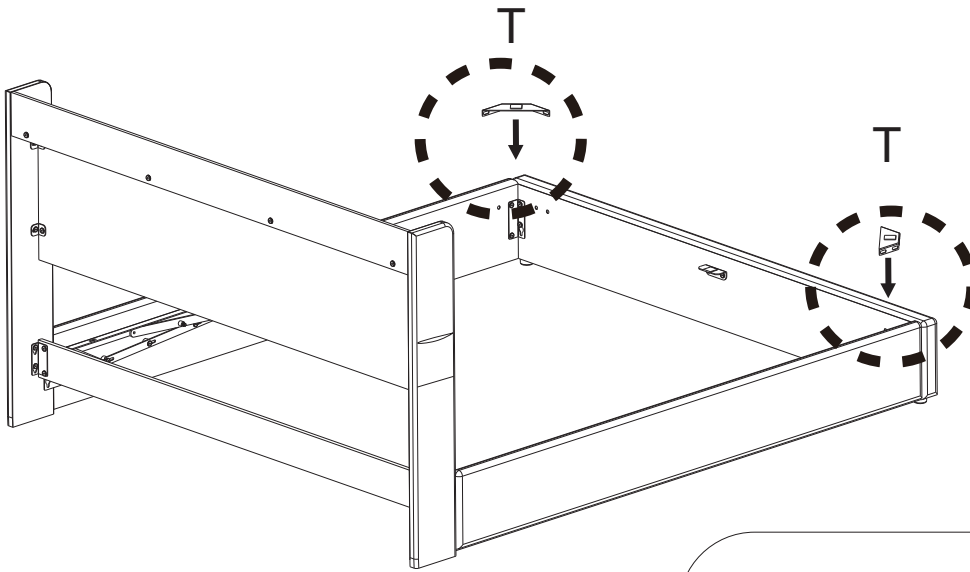
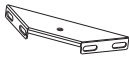

12

A x 1

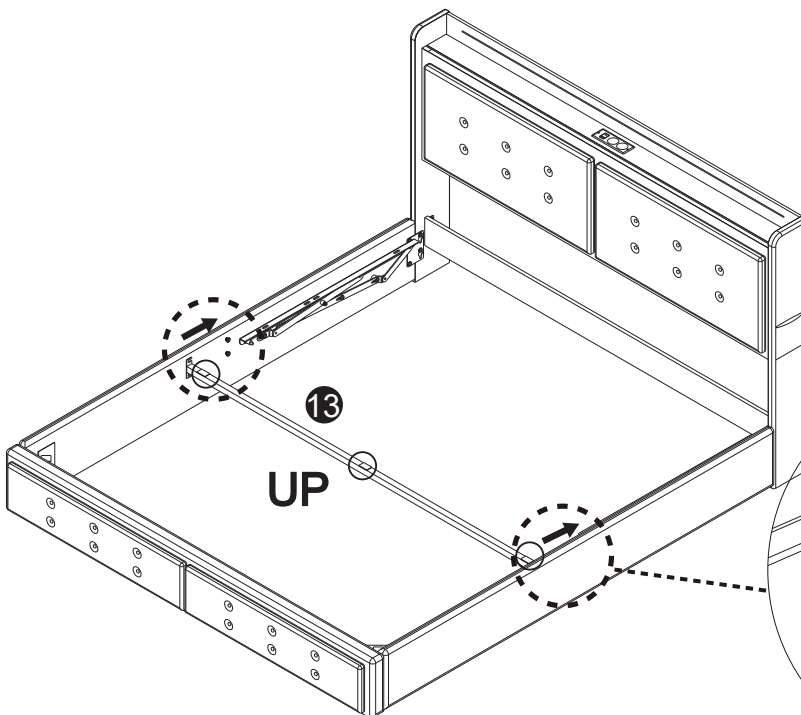

UP

13

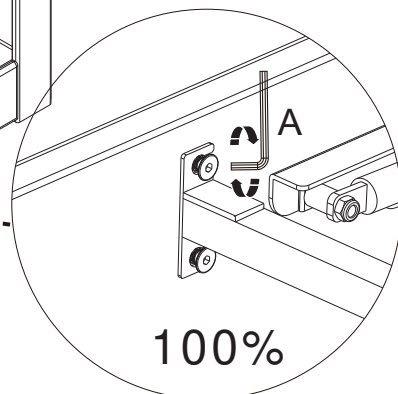

100%

# 13

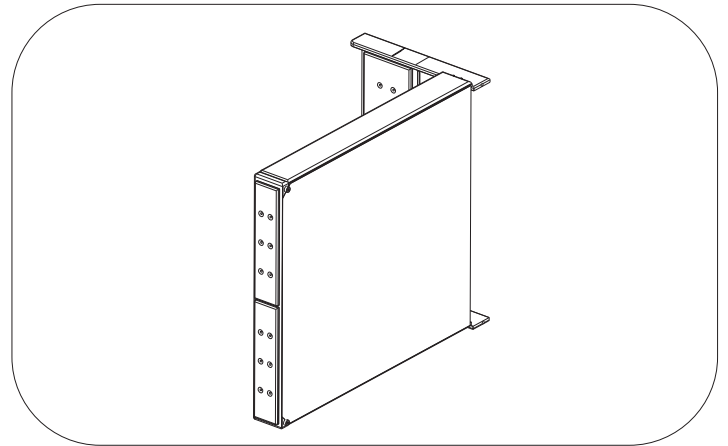
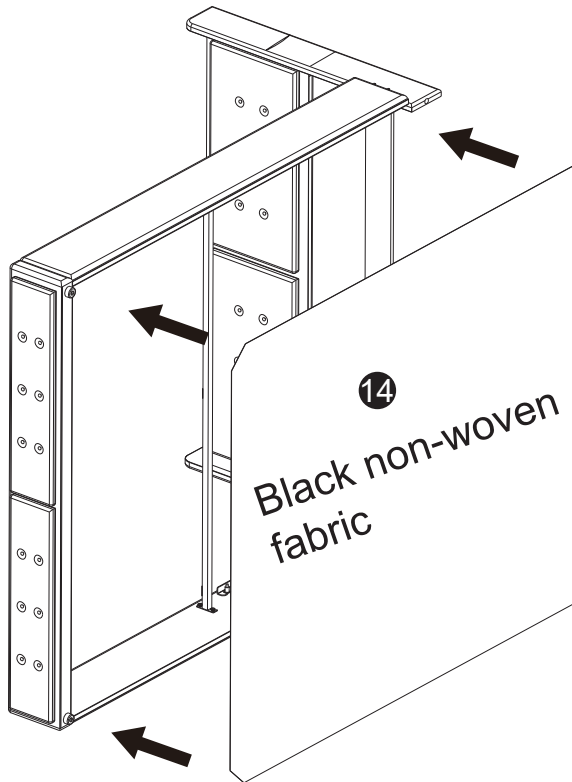

# 14

A x 1	H x 6 M8 x 40mm	J x 6	K x 6	L x 1

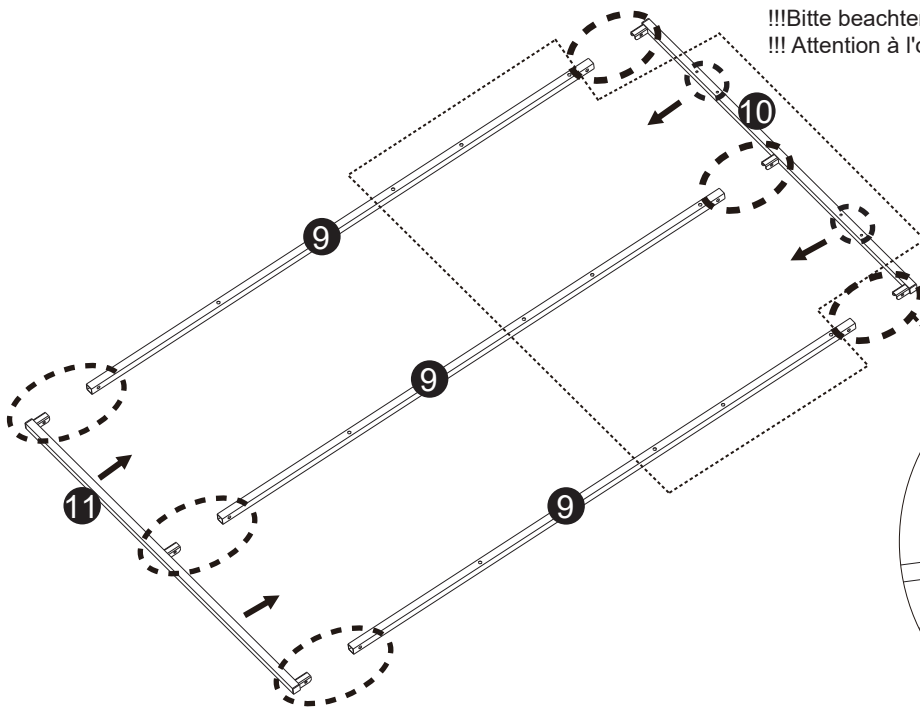

!!! Please aware the orientation of the holes on #9  
!!!Bitte beachten Sie die Ausrichtung der Löcher auf #9  
!!! Attention à l'orientation des trous sur le #9

15

A x 1



C x 2



M6 x 35mm

J x 2

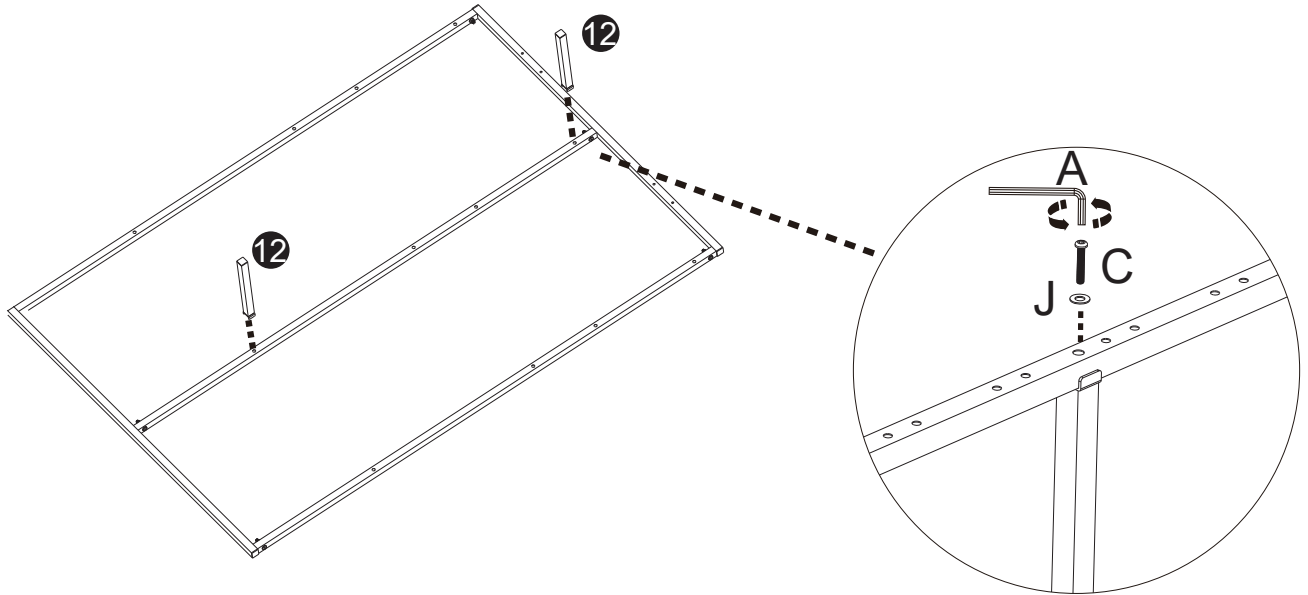

16

A x 1



H x 6



M8 x 40mm

K x 6



L x 1



W x 2

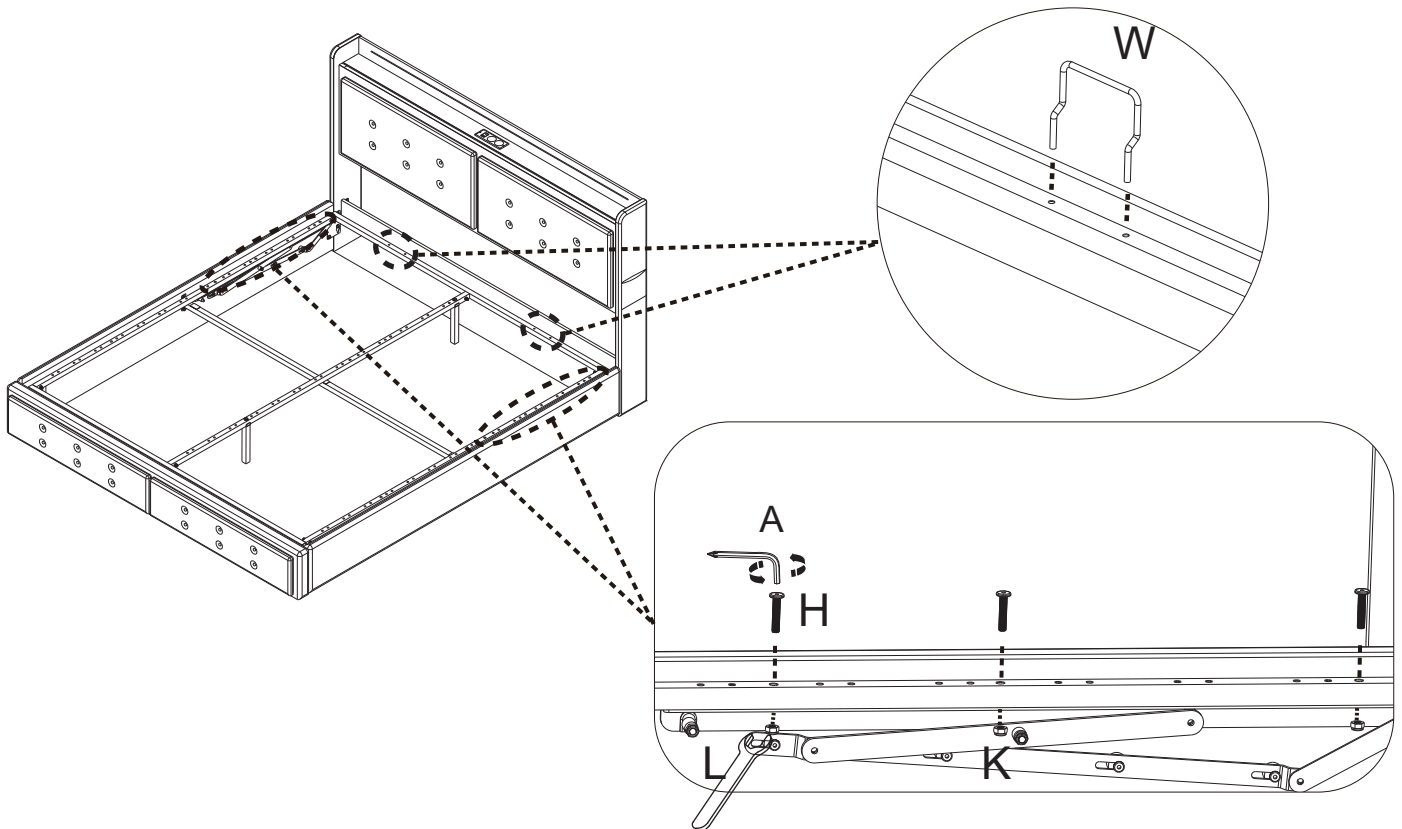

17

U x 26



V x 13



↑ UP

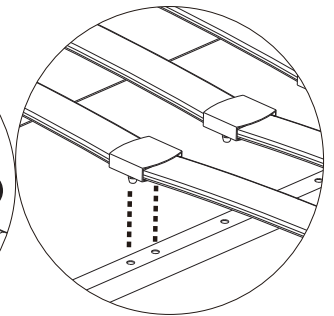
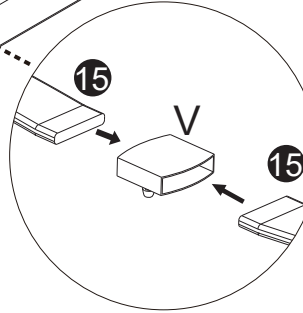
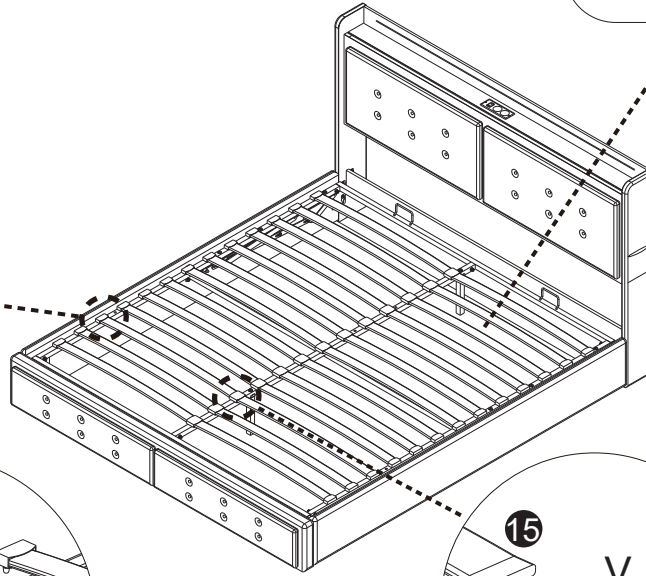
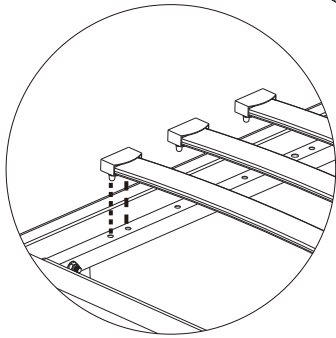
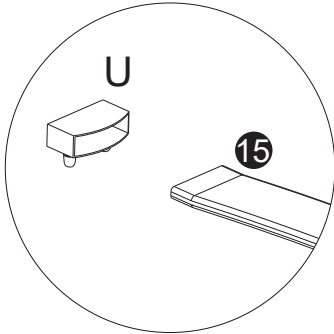

18

K x 4



L x 1

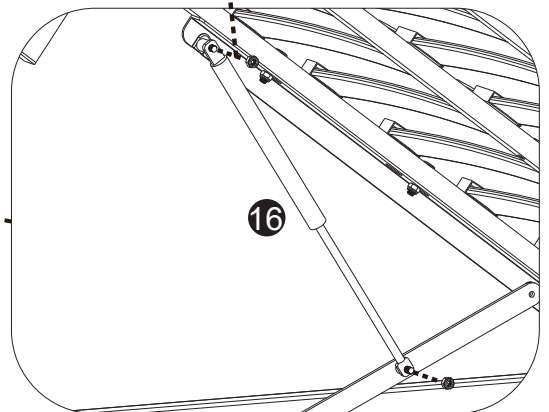
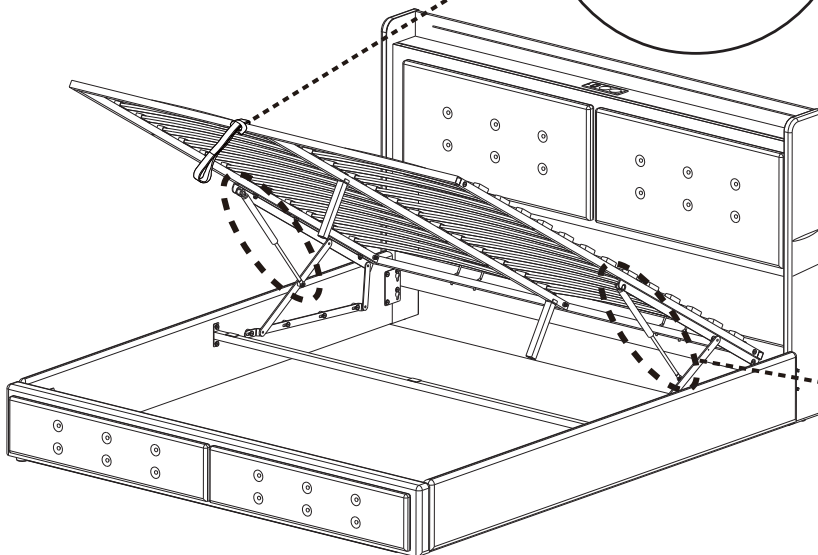
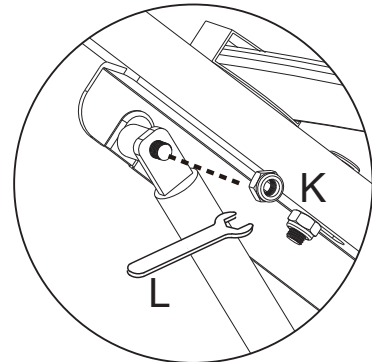
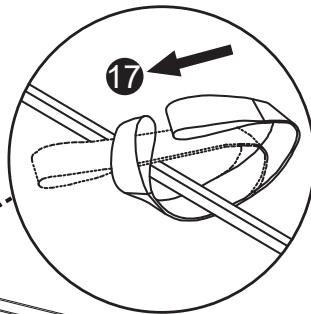

19

X x 1



Y x 1

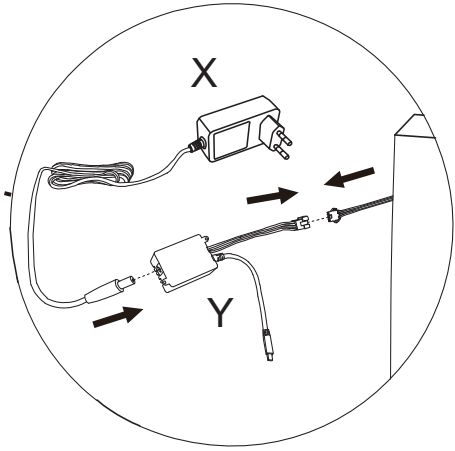
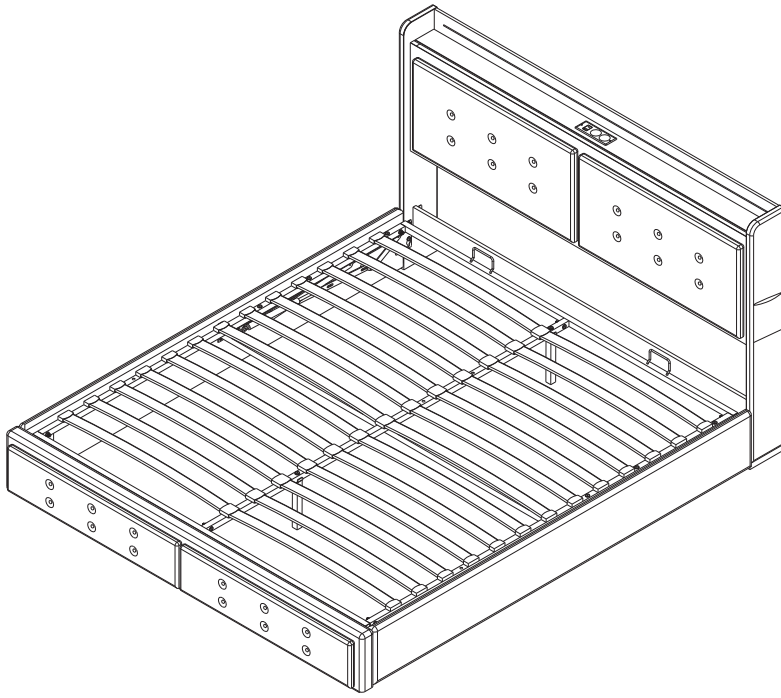

20

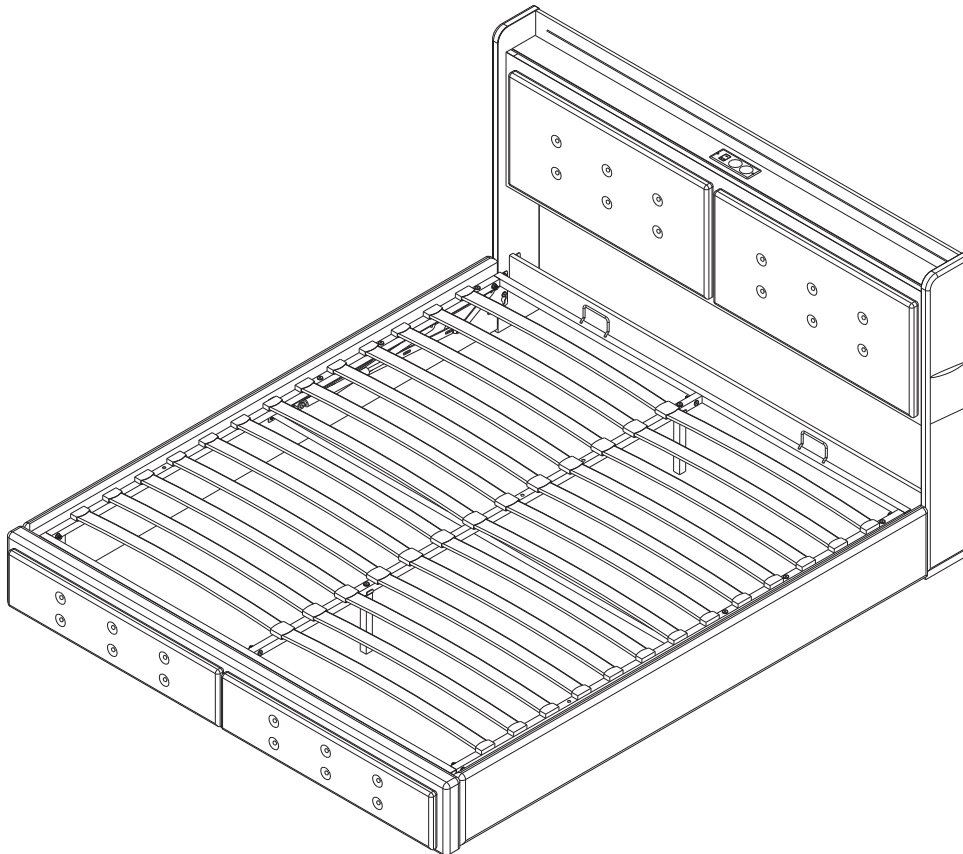

## LED light

If you can't let the lights work successfully, please check the following:

1. Please check the direction of the connect, try it in the opposite direction, according to the following picture.
2. Please check the remote control, it need you to tear down the plastic septum before use it.
3. Don't let the remote control too far from the receiver, make sure there is no obstruction between them.
4. If one of the colors is not bright, please check whether the four wires in the plug are skewed, and move the main line to make the four wires flush.

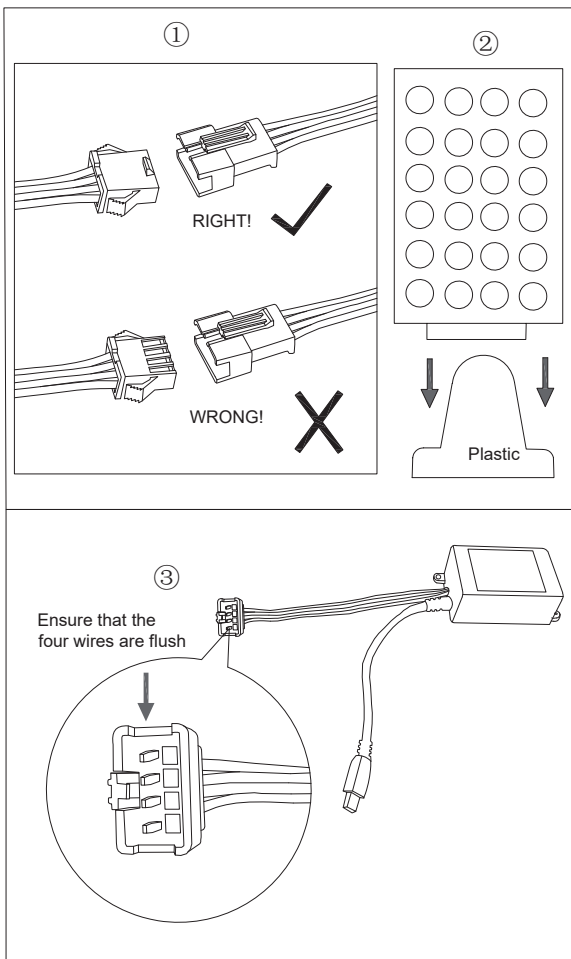

- 1 Please check the direction of the arrow
- 2 Please pull the plastic block out of the remote control
- 3 Please check whether the four wires of the plug are neat

## Operation Instructions of Controller

### I .Specifications:

Working temperature: -20-60 ℃      Supply voltage: DC12V

Output: Three CMOS drain- open output      Connecting Mode: Common anode

Max load current: 2 A each color

### II .Control Method:

Adopt IR remoter to control the led controller, which has 24 buttons, the function of each button as the table below:

Brightness +(Speed up)	Brightness -(Speed down)	Off	On
Static red	Static green	Static blue	Static white
Static orange	Static pea green	Static dark blue	7 color jumpy change
Static dark yellow	Static cyan	Static brown	All fade out&fade in
Static yellow	Static light blue	Static pink	7 color fade change
Static straw yellow	Static sky blue	Static purple	3 base color jumpy

### III. Panel specification and connecting drawing as follows:

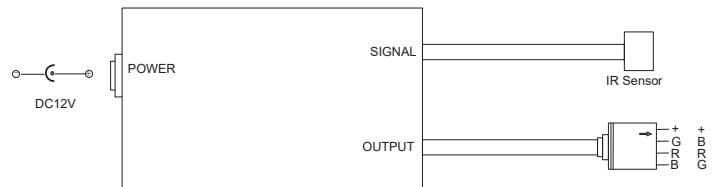

### IV. Warning:

1. Supply voltage of this product is DC12V never connect to DC24V or AC220V.
2. Never connect two wires directly in case of short circuit.
3. Lead wire should be connected correctly according to colors that connecting diagram offers.
4. Warranty of this product is one year, in this period we guarantee replacement or repairing with no charge, but exclude the artificial situation of damaged or overload working.

## ! WARNING

**THIS PRODUCT CONTAINS A BUTTON BATTERY**  
 If swallowed, a lithium button battery can cause severe or fatal injuries within 2 hours.  
 Keep batteries out of reach of children.  
 If you think batteries may have been swallowed or placed inside any part of the body, seek immediate medical attention.

# CERTIFICATE OF CONFORMITY

Certificate No.: KEYS240524062001EM-02

**Applicant** : Foshan Wei Guang Te Lighting Technology Co.,Ltd.  
**Address** : No.177,Bai'an South Road,Cangmen community Jun'an Town,  
Shunde District,Foshan City,Guangdong Province.China  
**Manufacturer** : Foshan Wei Guang Te Lighting Technology Co.,Ltd.  
**Address** : No.177,Bai'an South Road,Cangmen community Jun'an Town,  
Shunde District,Foshan City,Guangdong Province.China  
**Trade mark** : Wei Guang Te  
**Product** : LED Light Bar  
**Model No.** : WGT-A221116-12W,WGT-M2706-12W,WGT-M1808-12W,  
WGT-A250618-12W,WGT-A151010-12W,WGT-A221116-3W,  
WGT-A221116-5W,WGT-A221116-7W,WGT-A221116-9W,  
WGT-A221116-10W,WGT-M2706-3W,WGT-M2706-5W,  
WGT-M2706-7W,WGT-M2706-9W,WGT-M2706-10W,WGT-M1808-3W,  
WGT-M1808-5W,WGT-M1808-7W,WGT-M1808-9W,WGT-M1808-10W,  
WGT-A250618-3W,WGT-A250618-5W,WGT-A250618-7W,  
WGT-A250618-9W,WGT-A250618-10W,WGT-A250618-3W,  
WGT-A250618-5W,WGT-A250618-7W,WGT-A250618-9W,  
WGT-A250618-10W,WGT-A151010-3W,WGT-A151010-5W,  
WGT-A151010-7W,WGT-A151010-9W,WGT-A151010-10W

The submitted sample of the above equipment has been tested and found to comply with the following European Directive:

**EMC Directive - 2014/30/EU**

The standard(s) used for showing compliance with the essential requirements:

**Applicable Standard(s)** EN IEC 55015:2019+A11:2020  
EN IEC 61547:2023  
EN IEC 61000-3-2:2019+A1:2021  
EN 61000-3-3:2013+A1:2019+A2:2021

This certificate is part of the full test report(s) and should be read in conjunction with the test report: KEYS240524062001EM-02.

This certificate is based on an evaluation of one sample of above mentioned product. It does not imply assessment of the production of the product. Without the written approval of Guangdong KEYS Testing Technology Co., Ltd., this certificate is not permitted to be reproduced, except in full. It is not permitted to use the test lab's logo. The CE marking may only be used if all the relevant and effective European Directives are applicable.



Date: May 31, 2024

**Guangdong KEYS Testing Technology Co., Ltd.**

Address: Building 1, No.18, Shihuan Road, Dongcheng Subdistrict, Dongguan, Guangdong, China

104, No.4, Fumin Street, Shilong, Dongguan, Guangdong, China

Tel: + 86-0769-89798319 <http://www.keys-lab.com> E-mail: [info@keys-lab.com](mailto:info@keys-lab.com)

# Certificate

Certificate Number: UNIA22051009EC-11



Product: Power Adapter

Applicant: Zhongshan Yabo Electronic Technology Co., Ltd.  
4/f, 23 Kwong Lok Centre road, Lianfeng, Xiaolan, Zhongshan

Manufacturer: Zhongshan Yabo Electronic Technology Co., Ltd.  
4/f, 23 Kwong Lok Centre road, Lianfeng, Xiaolan, Zhongshan

Model No.: YB-1236, YB-1224, YB-1212

Trade Name: 雅之博

Test Methods: EN IEC 55015:2019/A11:2020  
EN IEC 61000-3-2:2019/A1:2021  
EN 61000-3-3:2013/A2:2021/AC:2022-01  
EN 61547:2009

The laboratory tested the product provided by the applicant according to the above test methods. According to the test results, the product conforms to EMC Directive (2014/30/EU) issued by the European Commission. It is possible to use CE marking to demonstrate the compliance with EMC Directive.

The certificate applies to the tested sample above mentioned only and shall not imply an assessment of the whole production. It is only valid in connection with the test report number: UNIA22051009ER-11.

May 25, 2022  
Issue Date

A handwritten signature in black ink, appearing to read "Hoffer Lau".



The CE marking, consisting of the letters "C" and "E" in a stylized font.

Shenzhen United Testing Technology Co., Ltd.

Shenzhen: 2/F., Annex Building, Jiahuangyuan Tech Park, No.305, Baotian 1st Road, Tiegang, Xixiang Street, Bao'an District, Shenzhen, Guangdong, China/518050

Guangzhou: No.47-3, Industrial Road, Zhushan, Dalong Street, Panyu District, Guangzhou, Guangdong, China/511450

Tel: +86-755-86180996 / +86-020-39277769 Fax: +86-0755-86180156

Web Site: [www.uni-lab.hk/](http://www.uni-lab.hk/) E-mail: [hofferlau@uni-lab.hk](mailto:hofferlau@uni-lab.hk)



Certificate of Compliance



# CERTIFICATE OF CONFORMITY

## Electromagnetic Compatibility (EMC) Directive 2014/30/EU

This Certificate of Conformity is hereby issued to the product designated below:

**Certificate No.** ..... : 23EP08001E01  
**Report No.** ..... : EP2308001E01  
**Date Issue.** ..... : 2023-08-23  
**Applicant's name** ..... : Shenzhen MingFuXin Furniture Electrical Appliances Co., Ltd.  
**Address** ..... : 4 F, building a, No. 8, Chenwu Road, Dakang community, Yuanshan street, Longgang District, Shenzhen  
**Manufacturer's name** ..... : Shenzhen MingFuXin Furniture Electrical Appliances Co., Ltd.  
**Address** ..... : 4 F, building a, No. 8, Chenwu Road, Dakang community, Yuanshan street, Longgang District, Shenzhen  
**Product Description** ..... : Socket  
**Model(s)/Type References** : OAZ-XXXX(The 1st "X" represents the switch, 0-1, the 2nd "X" represents the number of sockets 1-4, the 3th "X" represents the number of USB 1-3 (1 is double A, 2 is A+C,3 is double C), and the 4th "X" represents the wireless charge 0-1)  
**Parameters** ..... : See attachment for details  
**Standard(s)** ..... : EN 55032:2015+A11:2020+A1:2020  
EN 55035:2017+A11:2020  
EN IEC 61000-3-2:2019+A1:2021  
EN 61000-3-3:2013+A1:2019+A2:2021

On the basis of the referenced test report(s), sample(s) tested of the above product have been found to comply with the standards harmonized with the directives listed on this verification at the time the tests were carried out. Other standards and Directives may be relevant to the product. This verification is part of the full test report(s) and should be read in conjunction with it(them).

Once compliance with all product relevant CE mark directives are verified, including any relevant e.g. risk assessment and production control, the manufacturer may indicate compliance by signing a Declaration of Conformity themselves and applying the mark to products identical to the tested sample(s).

Approved By

  
Eric Liu  
Director of engineering department



Dongguan Pubiao Testing Technology Co., Ltd

No. 3, 1/F., Building A, No.30, Minghua Road, Juzhou, Shijie, Dongguan, Guangdong, China

Tel: +86 769 81813516 E-mail: service@pubiaotest.com Web: www.pubiaotest.com



# CERTIFICATE OF CONFORMITY

Electromagnetic Compatibility (EMC) Directive 2014/30/EU

Appendix of Certificate No.: 23EP08001E01

## Parameters:

Input: 220-250Vac, 50Hz, 10A

Output: AC socket: 2500W max

1)For USBA+Type-C output:

Type-C: 5VDC3A/9VDC2.22A/12VDC1.67A

USBA:5VDC3A/9VDC2A/12VDC1.5A

Type-C&USB: 5VDC/3A

Wireless:15W max

2)For double C output:

Type-C1: 5VDC3A/9VDC2.22A/12VDC1.67A

Type-C2:5VDC3A/9VDC2A/12VDC1.5A

Type-C1&Type-C2: 5VDC/3A

Wireless:15W max

3)For double A output:

USBA1:5VDC 2.1A

USBA2:5VDC 2.1A

USBA1&USBA2:5VDC/2.1A

Wireless:15W max



Dongguan Pubiao Testing Technology Co., Ltd

No. 3, 1/F., Building A, No.30, Minghua Road, Juzhou, Shijie, Dongguan, Guangdong, China

Tel: +86 769 81813516 E-mail: service@pubiaotest.com Web: www.pubiaotest.com