

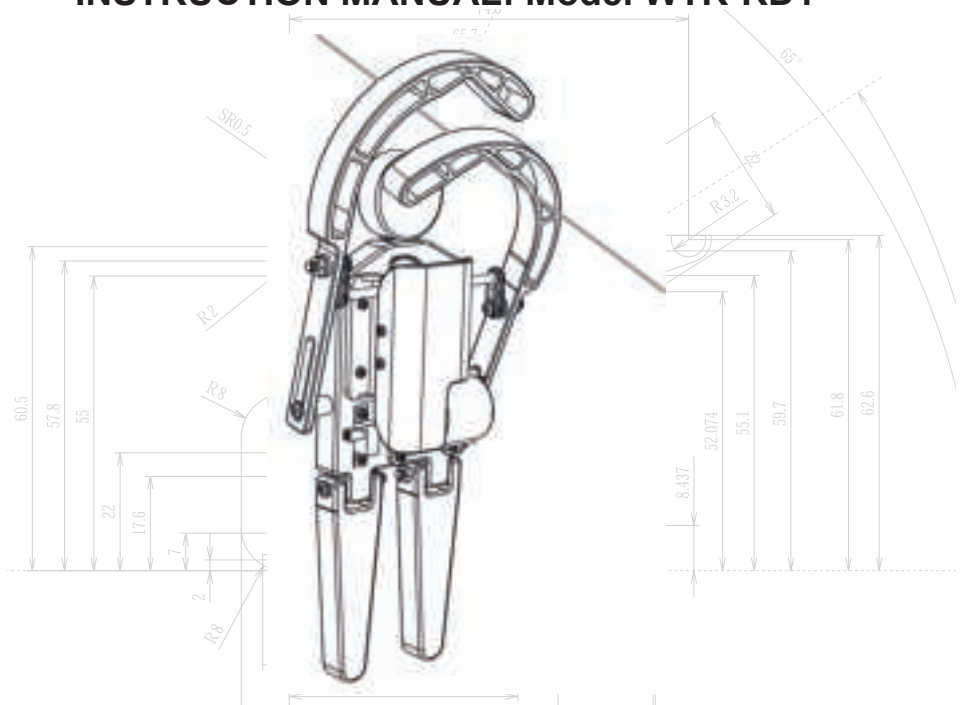

Educational Design Robot

ROPE DANCER

INSTRUCTION MANUAL: Model WTR-RD1



CONTENT

1. Product information Rope Dancer	3
2. General assembly information	4
2.1 Parts list Rope Dancer	6
3. Assembly instructions Rope Dancer	7
4. Gears information	13
5. Motors	14
5.1 History of motors	14
5.2 Motor mechanisms	14

© English translation (January 2010): AREXX Engineering (NL).

This description is protected by the laws of copyright. Any partial or total reproduction of the contents is prohibited without prior written authorisation of the manufacturer:
AREXX Engineering - Zwolle (NL).

The manufacturer and distributor cannot be held responsible for any damages occurred by mishandling, mounting mistakes or misuse due to a non-respect of the instructions contained in this manual.

The specification, shape and size of the product are subject to change without prior notice.



**Worldwide distributor:
AREXX Engineering
Zwolle, The Netherlands**

For technical support see:

www.arexx.com

© 2010 AREXX Engineering

1. PRODUCT INFORMATION ROPE DANCER

The Rope Dancer is a robot which can climb over a rope. Then it looks like if he is dancing because of the movements of the rope. However, before this robot can climb you have to build it first.

An excellent robot kit for beginners. This battery-controlled kit teaches the basic principles of robotic mechanics and motion. This simple robot can be assembled by almost anyone from age 8 and up. Only basic hand tools are required for the assembly. We already included a screwdriver and a wrench in this kit.

This robot kit is more than just fun. Assembling, building and following instructions help develop fine motor skills, hand-eye coordination and understanding technical drawings.

Specifications:

Power source	: 3V (2 Penlite AAA Batteries 1.5V, not included)
Current consumption	: Approx. 100 mA max.
Height	: 140 mm
Length	: 170 mm
Width	: 85 mm

Warning



- No return is possible after having opened the bags with components and pieces
- Prior to the assembly, read the manual thoroughly.
- Be careful when using tools.
- Keep this kit away from young children during construction and operation. (They might get hurt by the tools or swallow small components).
- Observe the correct polarity of the batteries.
- Keep the batteries dry. When the Rope Dancer gets wet, remove the batteries and let the Rope Dancer dry for some time.
- Remove the batteries when you will not use the Rope Dancer for a longer period.
- Children below 14 should only assemble this product with the help of adults.
- Use new batteries and do not MIX batteries (old, new, rechargeable) in any way!

2. GENERAL ASSEMBLY INFORMATION

IMPORTANT: First read all the instructions about the mechanics !

Follow the step-by-step instructions for the mechanical assembly as shown in this manual. Read and work very accurately, this is the best way to avoid assembly failures. When you follow the instructions and study the drawings and comments carefully, you have a big chance the robot will work directly and without any problems.

Also a great help is the picture on the package. You can see very clearly how the robot should look like. Best is that you only take out the parts from the packages and frames the moment you need them! Sometimes parts or bags are numbered.

All parts fit perfectly so you do not need to use force assembling this robot!

Do not hurry and once more, best is to read all instructions first before you actually start the assembly.

Small plastic Hammer



The correct tools already
do half of the job!

Screwdriverset

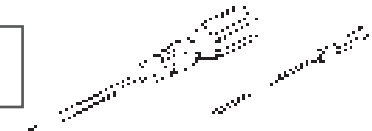

Always use a good fitting screwdriver size

Hobby knife



WARNING! Be carefull not to cut yourself when using a hobby knife!

Plier set with cutting plier & flatnose plier



Best plier size is approx. 150 mm.

How to cut the plastic parts

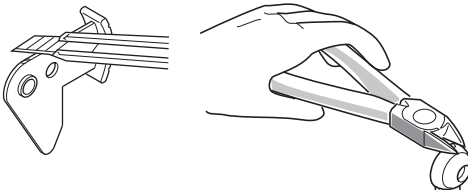

To take out the plastic parts from a frame, use a sharp hobby knife or a cutting plier. Cut carefully and take of the bosses with a knife to make it smooth.

Do not cut parts from a frame when you do not need them directly!

Assembly of a gear to an ax

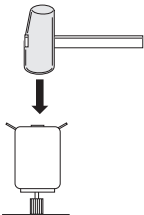

When you install a gear or a pinion to an ax or shaft, like the pinion to the motor shaft, you must be very careful. Be 100% sure you put the right gear onto the right ax. Best way is always to press the gear on the shaft with your hands. When you cannot manage it this way, use a very small plastic hammer. When you use a hammer, you can protect the gear or the shaft by putting a piece of wood or carton between the hammer and the part you will hit on.

Self-tapping screws (Parker)

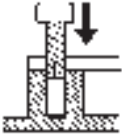

A self-tapping screw looks similar to a wood screw. When you screw it in a hole, it cuts the threads at the same time. Never try to screw it down all the way for a first time, because it may easily become stuck or you will damage its head.

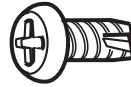

Tapping screws always have a sharp point, sometimes with a small carve. They look almost the same as screws which we use for wood, only the thread is more fine. The best way is to screw it in and out a bit.

1. Screw in
2. Screw out a bit
3. Screw in further and continue step 1 and 2

Do not screw a tapping screw in and out too often because the screw hole may become enlarged and the screw will loose all grip and proper function.

Screws and nuts

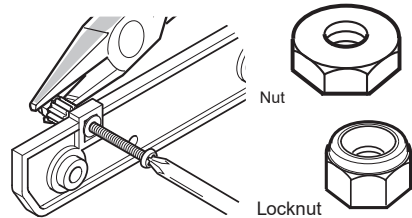
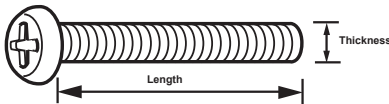

In a moving environment, screws and nuts must be tightened properly. A lock nut is a special nut with nylon inside which will lock itself automatically.

Another easy way to lock a screw is to use ordinary fingernail polish. A big advantage of nail polish is that you always can loosen it quite easily again. A professional way to lock a screw is to use for example locktite, a sort of glue especially made for screws, but it is very difficult to unlock such a screw afterwards.

The size of a screw is expressed by thickness and length. A screw with the marking M2 x 10 means 2 mm thick. The length of the thread is 10 mm. A M2 nut is used for a M2 screw, so the nut always corresponds with the screw thickness.































Wrench



This kit includes a small wrench. Please use this wrench to fit the M2 and M3 nuts in a proper way. You can use it instead of a plier.

2.1 Parts list ROPE DANCER

Please check all parts before you start the assembly!

<p>Screw short</p>  <p>M2 x 8 O 8 pcs.</p>	<p>Screw middle</p>  <p>M3 x 14 O 2 pcs.</p>	<p>Screw long</p>  <p>M3 x 24 O 2 pc.</p>	<p>Nut</p>  <p>M2 O 8 pcs.</p>	<p>Lock nut</p>  <p>M3 O 4 pcs.</p>	
<p><i>Tapping screws</i></p>					
<p>Roundhead Thin</p>  <p>M2 x 5 O 2 pcs.</p>	<p>Roundhead Thicker</p>  <p>M2.3 x 6 O 5 pcs.</p>	<p>Flathead countersunk</p>  <p>M3 x 6 O 2 pcs.</p>	<p>Roundhead with flange</p>  <p>M3 x 10 O 3 pcs.</p>		
<p>Motor Pinion gear</p>  <p>O 1 pc. 8 teeth</p>	<p>Flat spur gear with pinion small</p>  <p>O 1 pc. 28 and 10 teeth</p>	<p>Flat spur gear with pinion middle</p>  <p>O 1 pc. 30 and 10 teeth</p>	<p>Flat spur gear with pinion big</p>  <p>O 1 pc. 32 and 10 teeth</p>	<p>Gear with shaft</p>  <p>O 1 pc. 40 teeth</p>	
<p>Spacer</p>  <p>O 3 pc. Ø 4 - 4mm</p>	<p>Spacer</p>  <p>O 2 pc. Ø 4 - 6mm</p>	<p>Crank</p>  <p>O 2 pcs.</p>	<p>Motor Wired</p>  <p>O 1 pc. Wired</p>	<p>Rope</p>  <p>O 1 pc.</p>	<p>Wire's with connector</p>  <p>Complete set pre-soldered</p>
<p>Motor holder</p>  <p>O 1 pc.</p>	<p>Battery holder Wired</p>  <p>O 1 pc.</p>	<p>Head</p>  <p>O 1 pc.</p>	<p>Body</p>  <p>O 1 pc.</p>	<p>Gear cover</p>  <p>O 1 pc.</p>	<p>Switch Wired</p>  <p>O 1 pc.</p>
<p>Arm</p>  <p>O 2 pcs.</p>	<p>Leg</p>  <p>O 2 pcs.</p>	<p>Gearbox side panel 1</p>  <p>O 1 pc.</p>	<p>Gearbox side panel 2</p>  <p>O 1 pc.</p>		

3. ASSEMBLY INSTRUCTIONS ROPE DANCER

First always check and collect all the parts, as mentioned in the parts list, before you start the assembly!

Step 1: Assembly of the gearbox

Assemble the gearbox as shown on the drawing below:

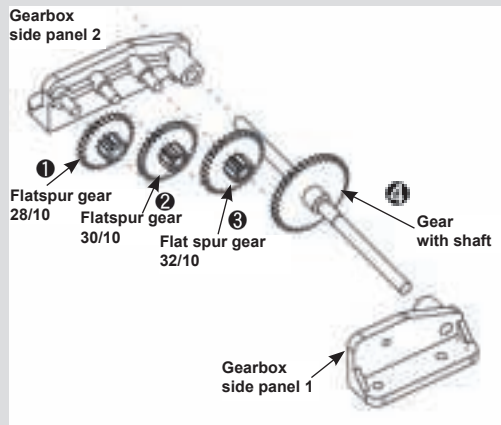

For the gearbox assembly you need;

- 1 pc. Flat spur gear with pinion small
- 1 pc. Flat spur gear with pinion middle
- 1 pc. Flat spur gear with pinion big
- 1 pc. Gearbox side panel 1
- 1 pc. Gearbox side panel 2
- 1 pc. Gear with shaft

Assemble the gear parts in order from 1 to 4.

Step 2: Installing the gearbox

To install the gearbox you need:

- 1 pc. Gearbox from step 1
- 1 pc. Body
- 4 pcs. Screw M2 x 8
- 4 pcs. Nut M2

Install the gearbox on the body as shown on the drawing:

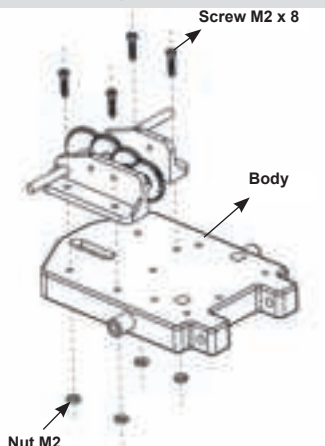

Step 3: Assembly motor pinion

For the motor pinion assembly you need:

- 1 pc. Motor pinion gear
- 1 pc. Motor

Put the pinion on the motor shaft as shown in the drawings:

Place the pinion on the motor shaft and install by **SOFTLY** tapping with a small hammer until pinion gear and motor shaft are flush. The best way to do it, if you have enough force, is to push the pinion on the shaft by hand, see the drawings below.

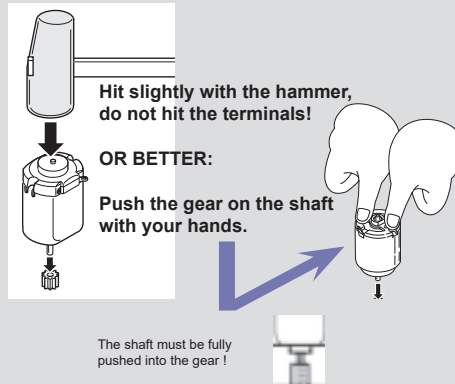

Step 4: Motor assembly

For the motor assembly you need:

- 1 pc. Motor of step 3
- 1 pc. Motor holder
- 2 pcs. Screw M2.3 x 6

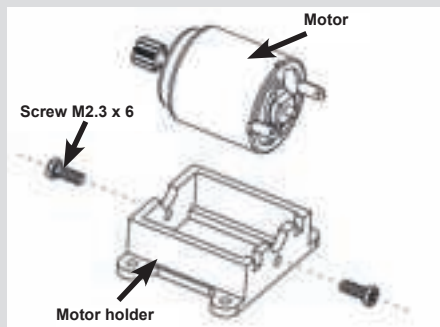

Install the motor on the holder as shown on the drawing:

Step 5: Installing the motor holder

To install the motor holder you need:

- 1 pc. Motor holder of step 4
- 1 pc. Body of step 2
- 4 pcs. Screw M2 x 8
- 4 pcs. Nut M2

Assemble the motor holder as shown on the drawing:

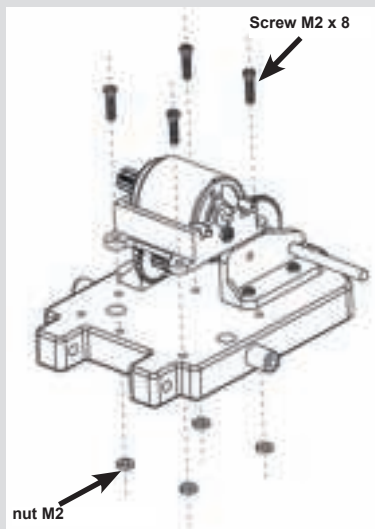

**After this step,
we will name the partially assembled body: CHASSIS!**

Step 6: Installing the arms

Assemble the arms as shown on the drawing:

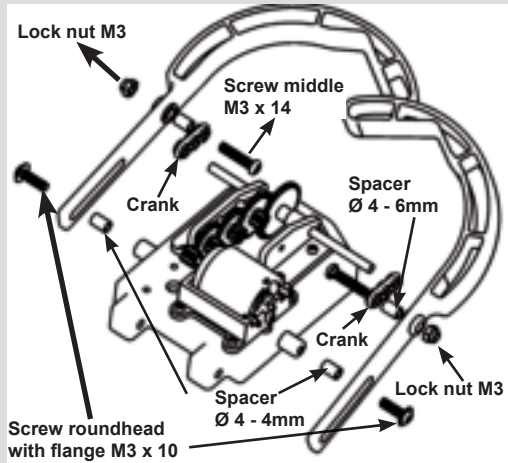

To install the arms you need;

- 1 pc. Chassis of step 5
- 2 pcs. Arm
- 2 pcs. Crank
- 2 pcs. Spacer Ø 4 - 4mm
- 2 pcs. Spacer Ø 4 - 6mm
- 2 pcs. Screw middle size M3 x 14
- 2 pcs. Lock nut M3
- 2 pcs. Screw roundhead with flange M3 x 10

NOTICE!
Assemble the cranks 180 degrees.
Details are shown on the drawing!

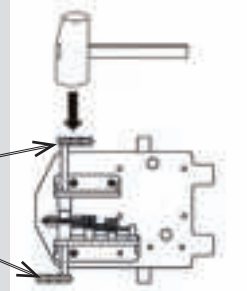

Step 7: Installing the battery holder

For the battery holder installation you need:

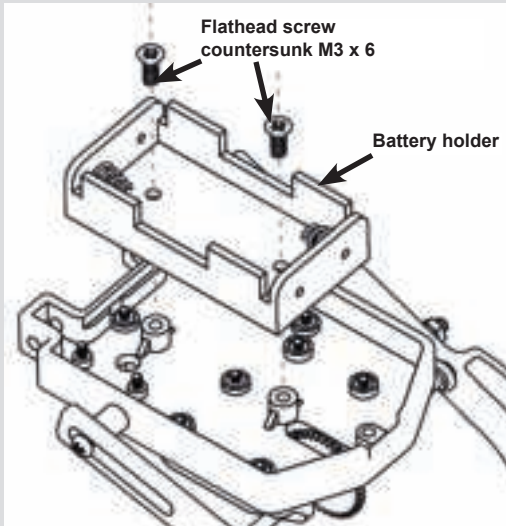

- 1 pc. Chassis of step 6
- 1 pc. Battery holder
- 2 pcs. Flathead screw Countersunk M3 x 6

Install the battery holder as shown on the drawing:

Step 8: Installing the head

Install the head as shown on the drawing:

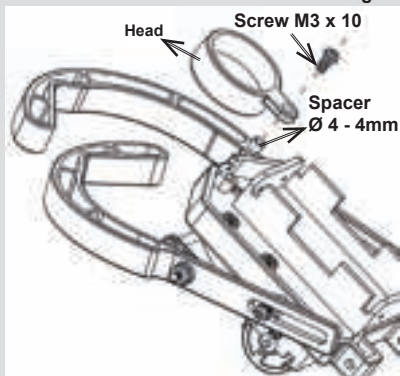

To install the head you need:

- 1 pc. Chassis of step 6
- 1 pc. Head
- 1 pc. Screw roundhead M3 x 10
- 1 pc. Spacer Ø 4 - 4mm

Step 9a: Installing the legs

Install the legs as shown on the drawing:

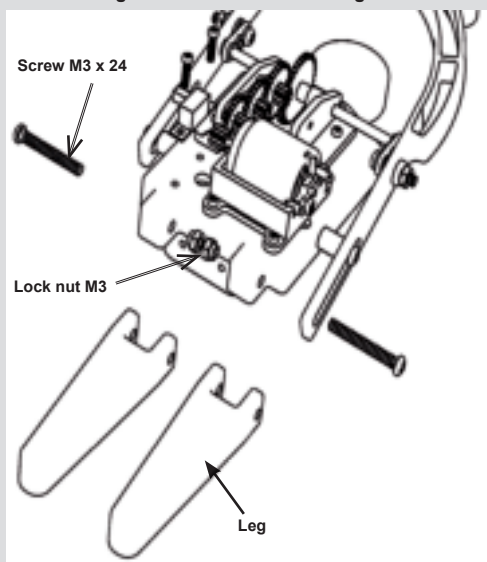

To install the legs you need:

- 1 pc. Chassis of step 8
- 2 pcs. Leg
- 2 pcs. Screw long M3 x 24
- 2 pcs. Lock nut M3

Step 9b: Installing the switch

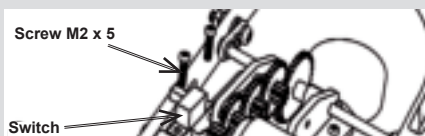

To install the switch you need:

- 1 pc. Chassis of step 9a
- 1 pc. Switch
- 2 pcs. Roundhead screw M2 x 5

Step 10: Final assembly

Install the gearbox cover as shown on the drawing:

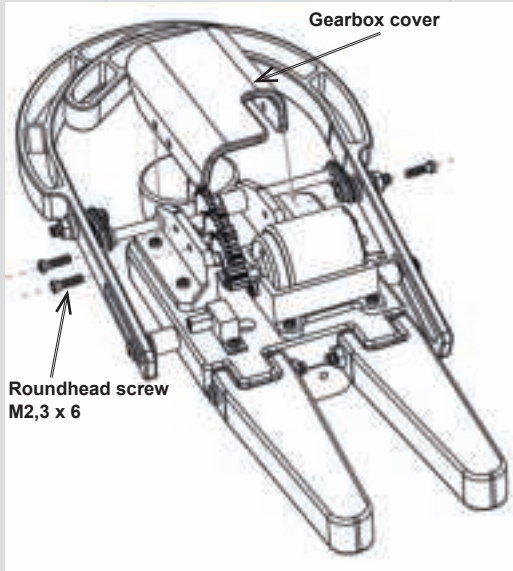

For the final assembly you need:

- 1 pc. Chassis of step 9b
- 1 pc. Gearbox cover
- 3 pcs. Roundhead screw M2,3 x 6

Step 11: The wiring diagram

Connect the wires as shown on picture.

Check the wiring carefull, it should exactly look the same like the drawing below:

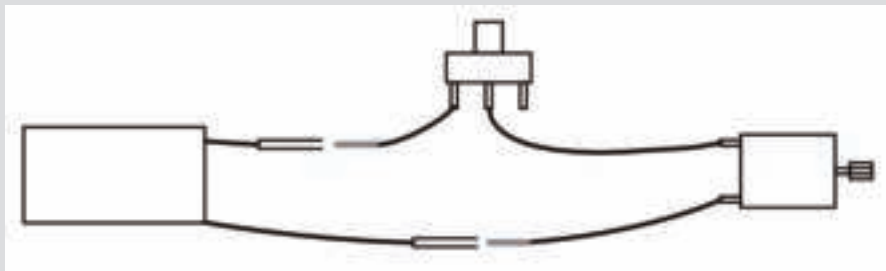

Step 12: Inserting the batteries

Place the batteries as shown on the picture:

The way the motor rotates is depending on the polarity of the batteries!!

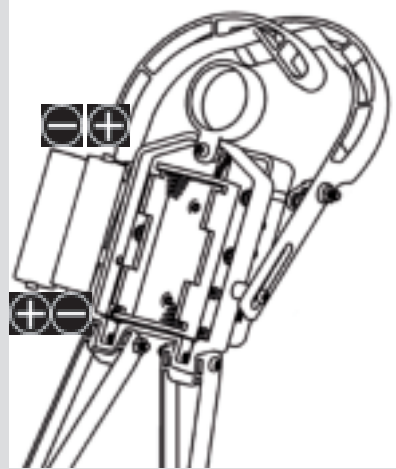

Last step: Practice test

Place the Rope Dancers arms around the rope as shown on the picture and put the switch in the ON position.

If the Rope Dancer does not move forward, change the polarity of the batteries!

If the motor does not move at all check:

- Batteries: Are they FULL?
- Wiring: See page 11
- Gears: See page 7

Most likely problems are gear assembly or poor batteries.

Worst case is that you have to disassemble the Rope Dancer and build it all over again.

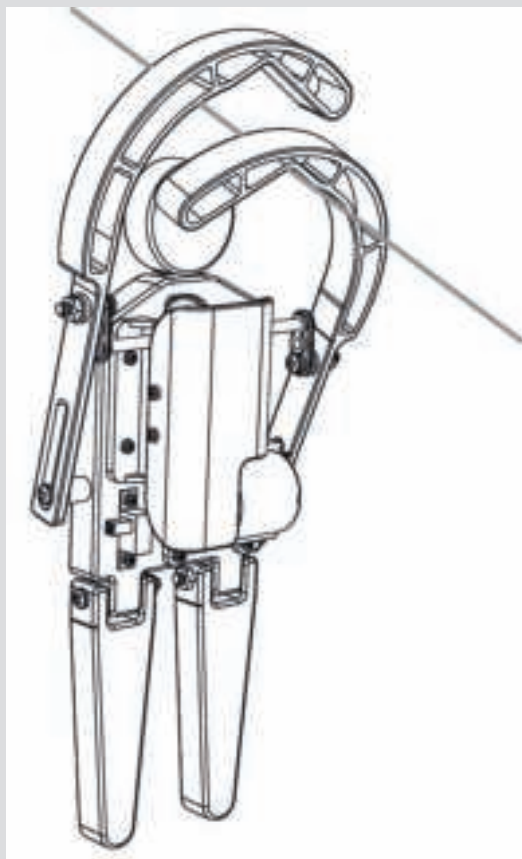

4. GEARS INFORMATION

The mechanics of the Rope Dancer consists of two parts. The first part is the gearbox, which takes care that the power from the motor shaft is converted to the crank. The second part is to convert the rotation of the crank into a movement of the arms.

Transmission of power

Gears, transmission belts, shaft, crank, chains: They all can transmit power. In the Rope Dancer, four gears transfer the motor power into the crank. Such a transmission is called a gearbox. The Rope Dancer motor rotates very fast with only a little torque. However, for the crank we need low rotation speed and high torque. The power is transmitted by the teeth of the gears. At the same time, three conversions take place:

- Change in rotating direction
- Change in rotating speed
- Change in torque

a. Change in rotating direction

When two gears are connected, there will be a change in rotation direction. One gear will rotate clockwise, the other gear will rotate counter-clockwise.

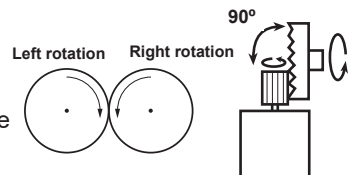

b. Change in rotating speed

The change in rotating speed depends on the relation of the teeth in the gear. As an example we describe a gear with 10 teeth and a gear with 40 teeth. When the first gear (10 teeth) makes a full rotation, the second gear (40 teeth) only makes a quarter of a rotation. So before the second gear makes a full rotation, the first gear already makes four rotations. You may understand that this effect also changes the rotating speed.

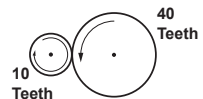

c. Change in torque

The torque can be seen as a lever construction with a fulcrum. Imagine a person who lifts a stone with a lever.

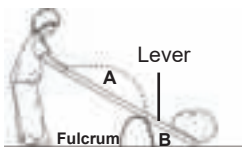

The person who lifts the lever must use more force when the distance A gets shorter or when the distance B gets longer.

$$\text{Rotation Ratio} = \frac{\text{Motor rotation}}{\text{Rotation last gear}}$$

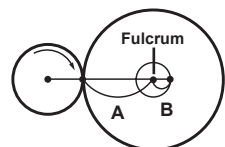

5. MOTORS

Explanation of motors:

There are many things around us in which motors are used. For example, a mobile phone uses a motor for the vibration mechanism. A fan inside of a hair dryer is turned by a motor. Motors are also being used to turn the wheels of a train. If there were no motors in the world, our present life would not be as it is.



5.1 History of motors

The prototype of the first electric motor was made by an English physicist, Michael Faraday, in the beginning of the nineteenth century and was based on the discovery of electromagnetic induction. Faraday noticed that when electricity ran into a generator which had the same structure as a motor, it started to turn. On account of the fact that the generator was invented earlier than the electric motor, this story is probably true. Around the same period, an American physicist, Joseph Henry, was also working on a prototype electric motor. However, because Faraday made his research presentation earlier, he is regarded as the inventor of the motor.

5.2 Motor mechanisms

Electric motors turn by using the power of two different kinds of magnets. One is a regular magnet (permanent magnets), which you know as a magnet. The other is the electromagnet which is made by running the electric current through it. Both types of magnets have north and south poles. The polarity of permanent magnets will not change; The polarity of electromagnets will switch when the electric current flow changes direction. Both types of magnets have the characteristic that like poles they attract each other, and unlike poles they repel each other.



How are magnets used in motors? Common DC motors in small sized plastic models, such as the Rope Dancer, consist of the following items: permanent magnets, turning axles, electromagnet cores wrapped with enameled wire, commutators to change the direction of electric current flow of the electromagnets and brushes to make contact with commutators. When the electric current is running to the motor from the outside, the core becomes magnetized.

Then the core starts turning because of attraction and repulsion, which are created by the polarity of the electromagnet and the permanent magnets around it. When the electromagnet's south and permanent magnet's north attract each other, the core would stop. However, the electric current flow inside the electromagnet will be reversed by the commutator. As a result, the electromagnet's polarity will become the same as the permanent magnet. Since like poles repel, the core will turn again. By repeating this cycle, the core will continue to turn. The axle of the motor is attached to the core and will rotate as the core turns.

