

4 Series Premium S



FR Instructions de montage

GB Assembly instructions

DE Montageanleitung

NL Montage-instructies

IT Istruzioni per il montaggio

ES Instrucciones de montaje

PT Instruções de montagem

NO Monteringsinstrukser

DK Monteringsvejledning

SE Monteringsanvisningar

FI Kokoamisohjeet

PL Instrukcja montażu

CZ Návod k montáži

SI Navodila za montažo

SK Návod na montáž

HU Összeszerelési utasítás

HR Upute za montiranje

RO Instrucțiuni de montaj

BG Указания за монтаж

TR Montaj

GR Οδηγίες συναρμολόγησης

IS Leiðbeiningar um samsetningu

LT Surinkimo instrukcija

EE Kokkupanemise juhised

LV Montāžas norādījumi

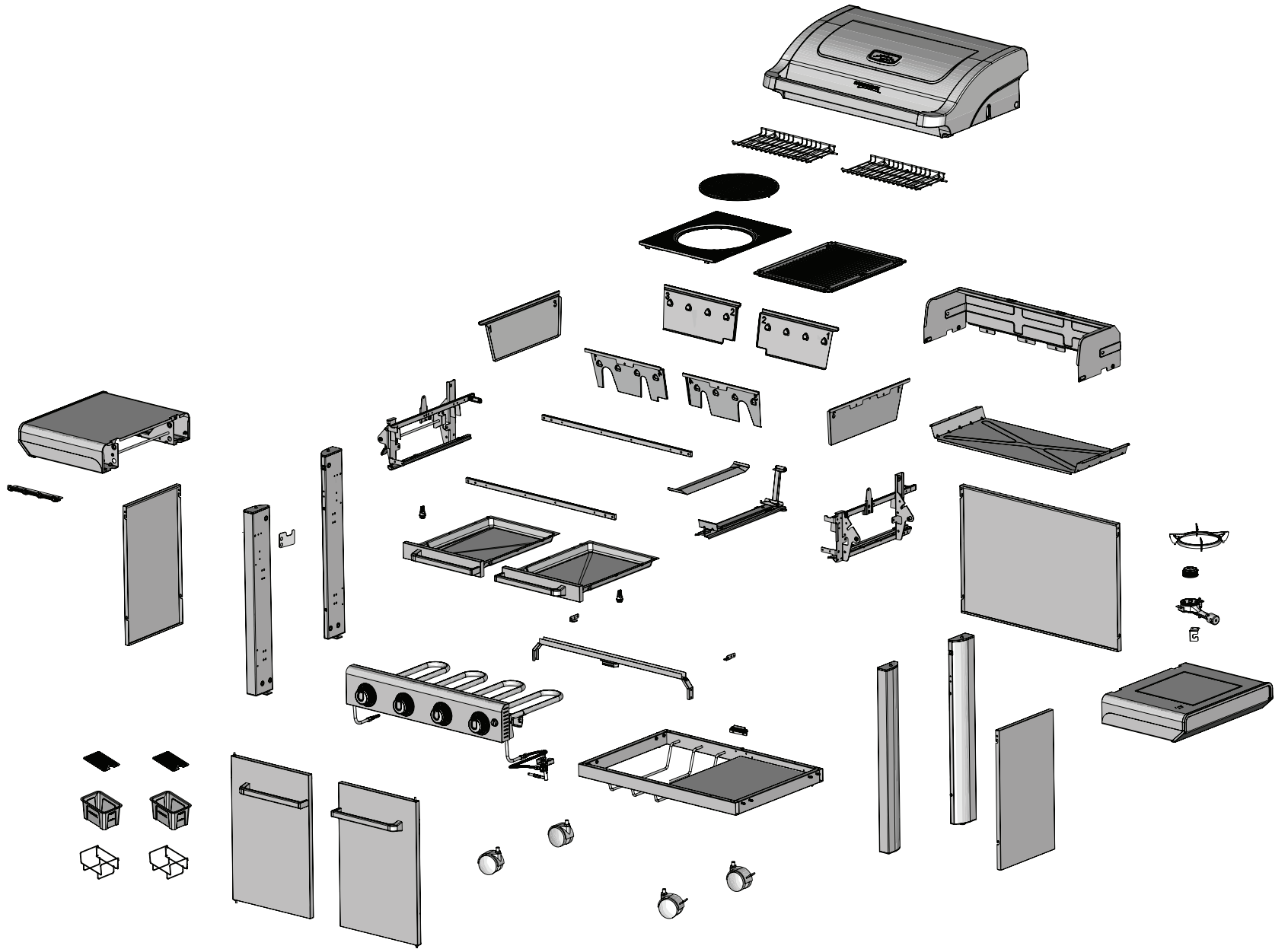

4 Series Premium S	
1	
1	
1	
1	
1	
1	

4 Series Premium S	
1	
1	
1	
1	
2	
1	

4 Series Premium S	
2	
1	
1	
1	
1	
1	
1	
1	
1	

4 Series Premium S	
1	
1	
1	
1	
1	
1	
1	
1	
2	





4 Series Premium S	
2	
1	
1	
1	
1	
1	
1	
1	
1	

4 Series Premium S	
2	
2	
2	
1	

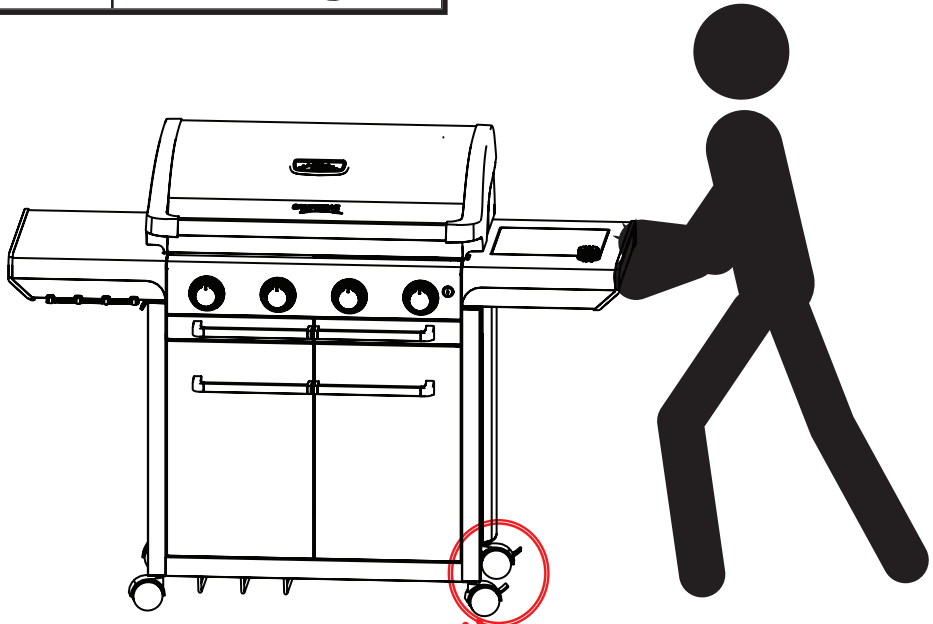
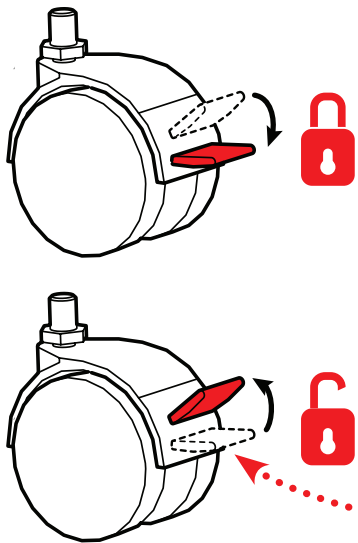
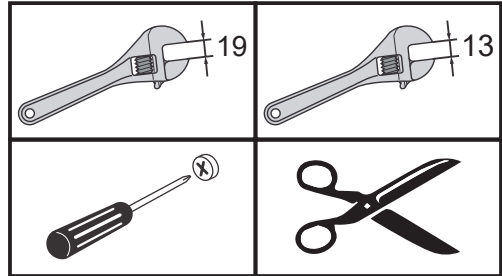
4 Series Premium S	
1	
1	
2	
1	

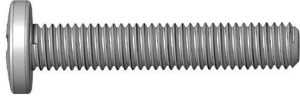
4 Series Premium S	
1	

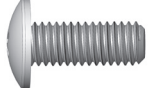
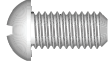
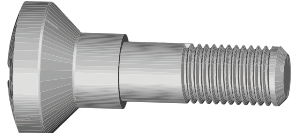

4 Series Premium S	
8	 a
8	 b
10	 c
41	 d
2	 e
2	 f
4	 g



- FR** - 1. Prévisser (visser en partie préalablement) les vis et écrous en position sans serrer pour faciliter l'ajustement relatif des pièces.
2. Une fois le prémontage terminé, serrer les vis et écrous.
- GB** - 1. Put all screws and nuts in place without tightening.
2. Tighten the screws and nuts.
- DE** - 1. Stecken Sie alle Schrauben und Muttern an ihren Platz, ohne sie anzuziehen.
2. Ziehen Sie die Schrauben und Muttern an.
- NL** - 1. Zet alle schroeven en moeren op hun plaats zonder ze aan te draaien.
2. Draai de schroeven en moeren aan.
- IT** - 1. Mettere tutte le viti e i dadi in posizione senza serrare.
2. Stringere le viti e i dadi.
- ES** - 1. Ponga todos los tornillos y tuercas en sus lugares correspondientes sin apretarlos.
2. Apriete los tornillos y las tuercas.
- PT** - 1. Aponte todos os parafusos e porcas sem os apertar.
2. Aperte os parafusos e as porcas.
- NO** - 1. Sett inn alle skruer og mutre uten å dra dem til.
2. Dra til skruene og mutrene.
- DK** - 1. Sæt alle skruer og møtrikker på plads uden at spænde.
2. Spænd skruerne og møtrikkerne.
- SE** - 1. Sätt i alla skruvar och muttrar utan att dra åt.
2. Dra åt skruvarna och muttrarna.
- FI** - 1. Aseta kaikki ruuvit ja mutterit paikoilleen kiristämättä.
2. Kiristä ruuvit ja mutterit.
- PL** - 1. Włóż wszystkie śruby i nakrętki na miejsce, ale nie dokręcaj.
2. Dokręć wszystkie śruby i nakrętki.
- CZ** - 1. Všechny šrouby a matice vložte bez utažení na místo.
2. Utáhněte šrouby a matice.
- SI** - 1. Vstavite vse vijake in matice na mesto brez zategovanja.
2. Privijte vijake in matice.
- SK** - 1. Zaskrutkujte všetky skrutky a matice bez toho, aby ste ich utiahli.
2. Utiahnite skrutky a matice.
- HU** - 1. Valamennyi csavart és anyát csavarja vissza a helyére, de ne húzza meg.
2. Húzza meg a csavarokat és anyákat.
- HR** - 1. Postavite sve vijke i matice na njihovo mjesto bez pritezanja.
2. Pritegnite vijke i matice.s.
- RO** - 1. Puneți toate șuruburile și piulițele pe poziție fără a le strânge.
2. Strângeți șuruburile și piulițele.
- BG** - 1. Поставете всички винтове и гайки на място, без да ги затягате.
2. Затегнете винтовете и гайките.
- TR** - 1. Tüm vidaları ve somunları, çok fazla sıkmadan yerine yerleştirin.
2. Vidaları ve somunları sıkın.
- GR** - 1. Τοποθετήστε όλες τις βίδες και τα παξιμάδια στη θέση τους χωρίς να σφίξετε.
2. Σφίξτε τις βίδες και τα παξιμάδια.
- IS** - 1. Settu allar skrúfur og rær á sinn stað án þess að herða þær.
2. Hertu skrúfur og rærnar.
- LT** - 1. Visus varžtus ir veržles sudėk į jų vietas, bet nepriveržk.
2. Priveržk varžtus ir veržles.
- EE** - 1. Pange kõik kruvid ja mutrid pingutamata kohale.
2. Pingutage kruvid ja mutrid.
- LV** - 1. Novietojiet vietā visas skrūves un uzgriežņus, nepievelkot tos.
2. Pievelciet skrūves un uzgriežņus.

01A

2x  d

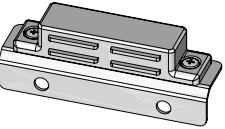
1x 

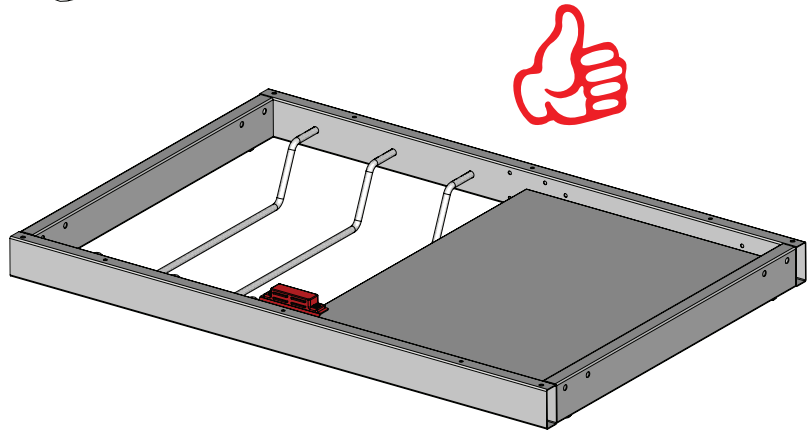
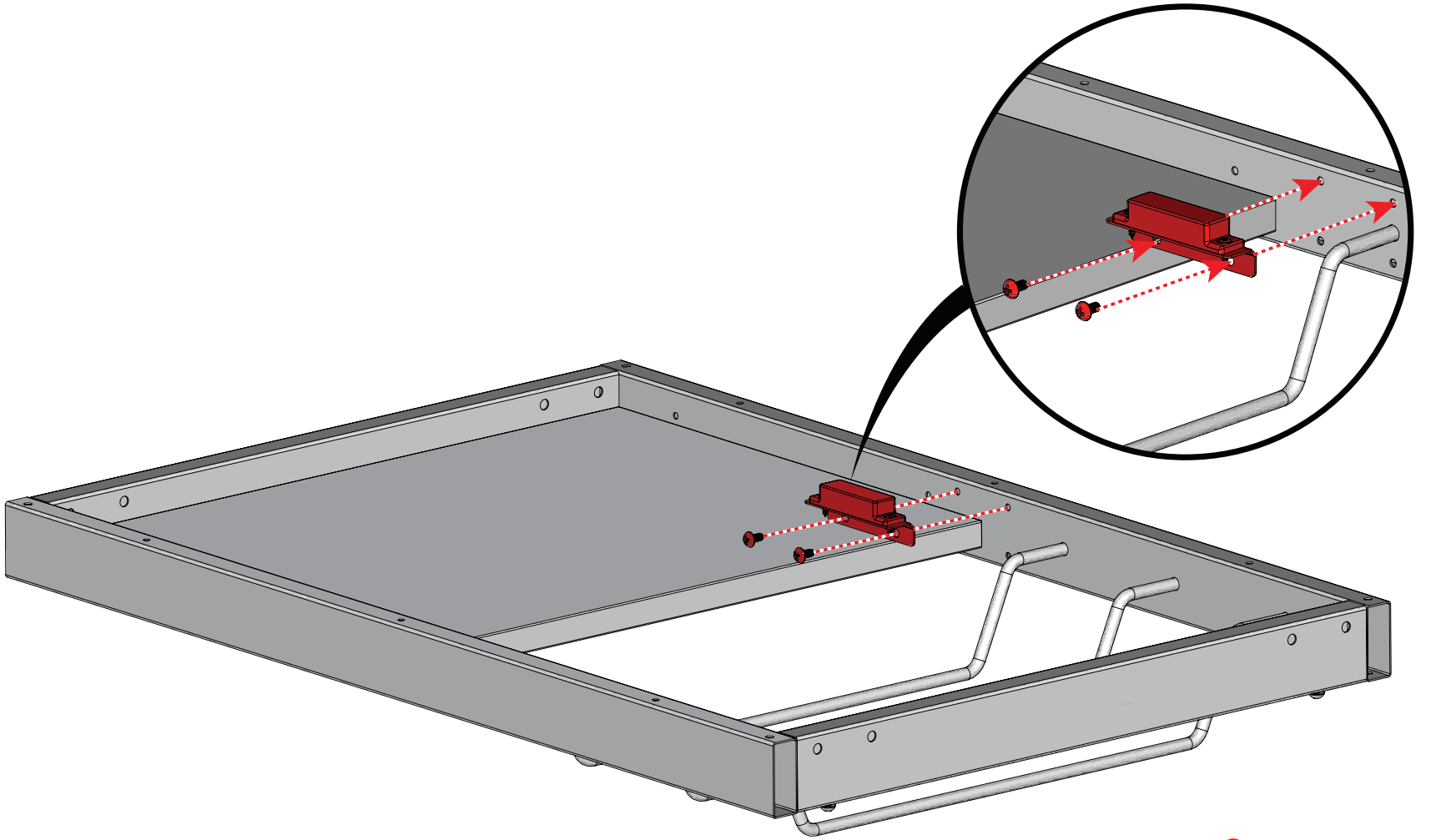
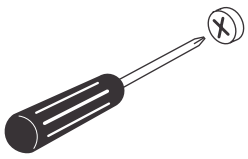

01B

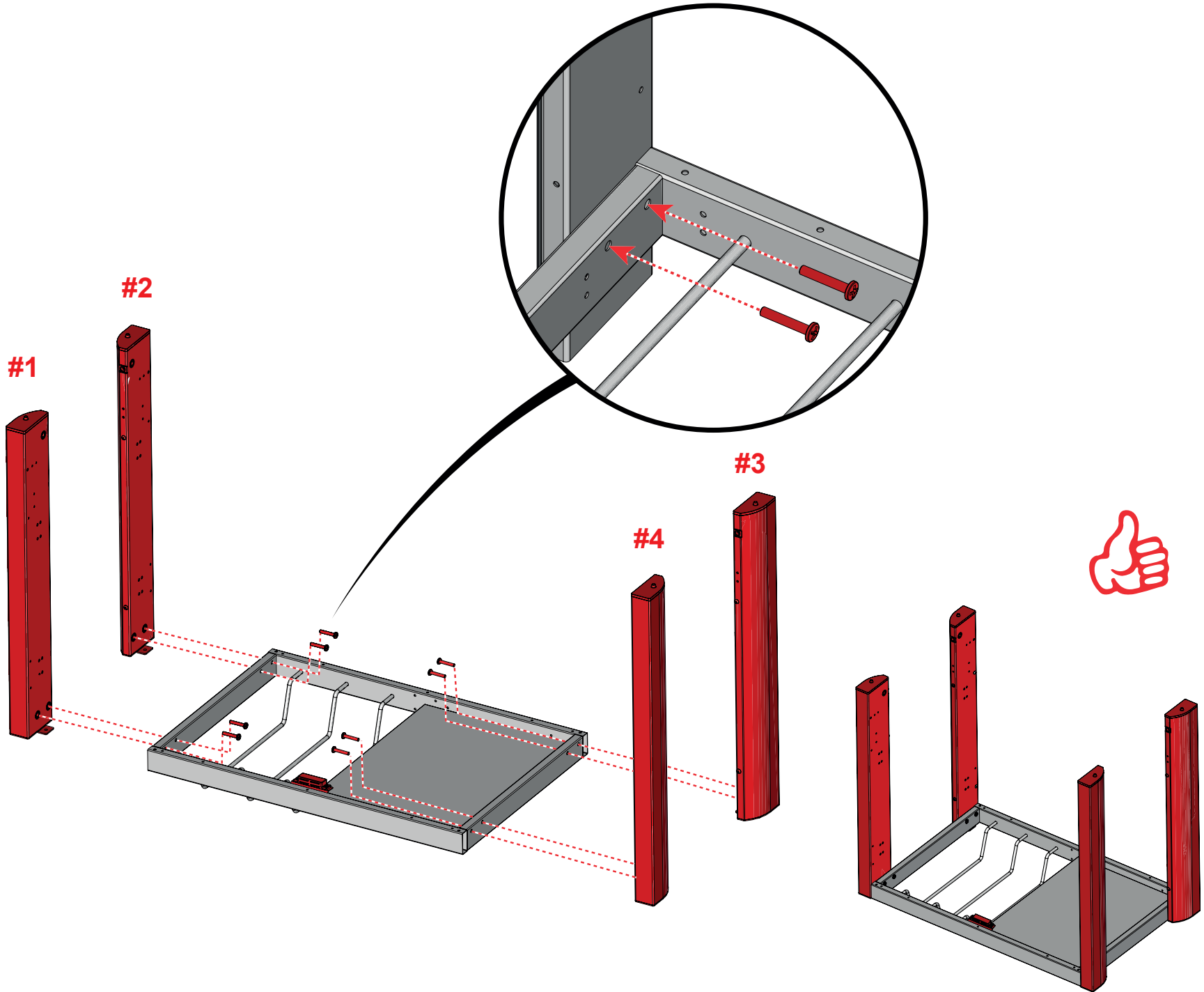
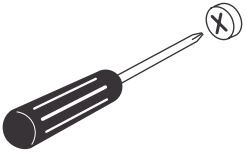
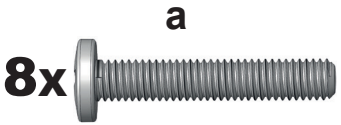

02

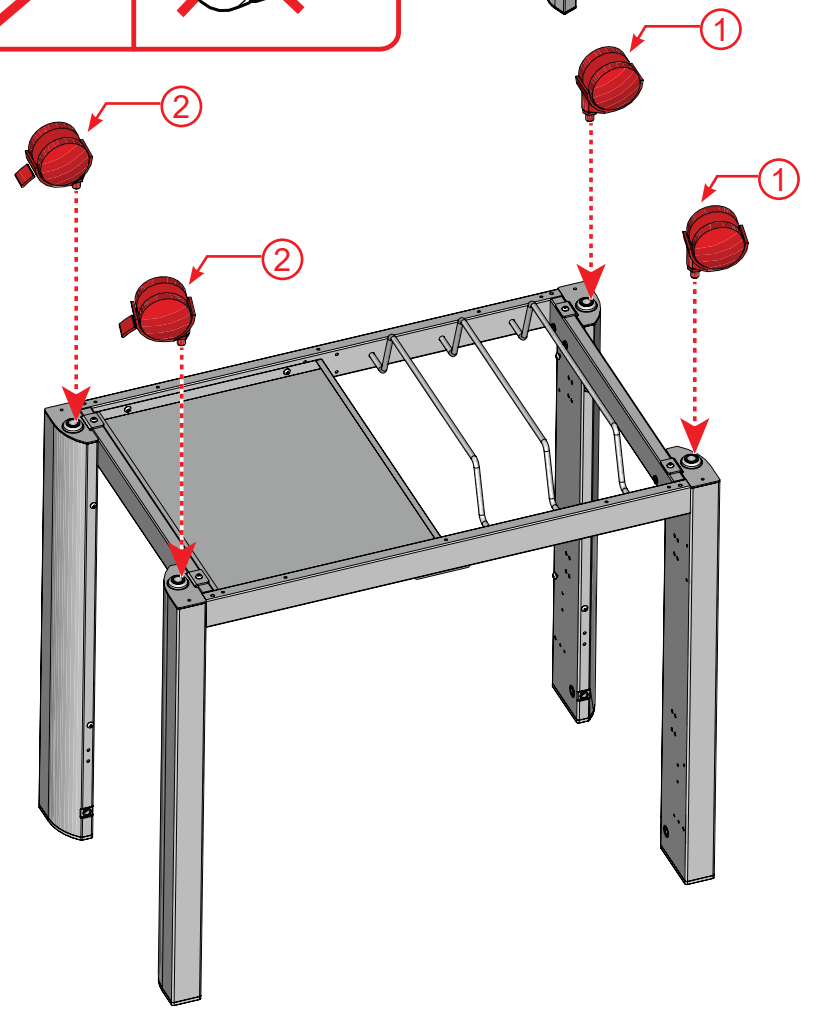
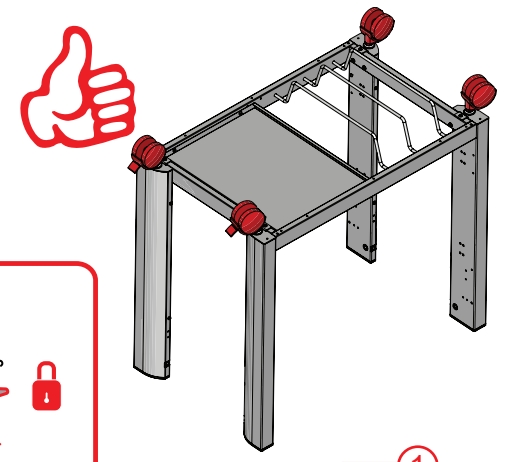
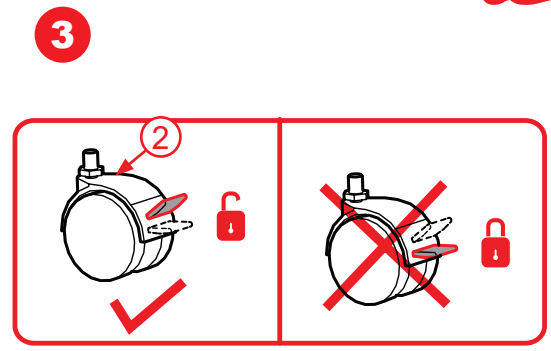
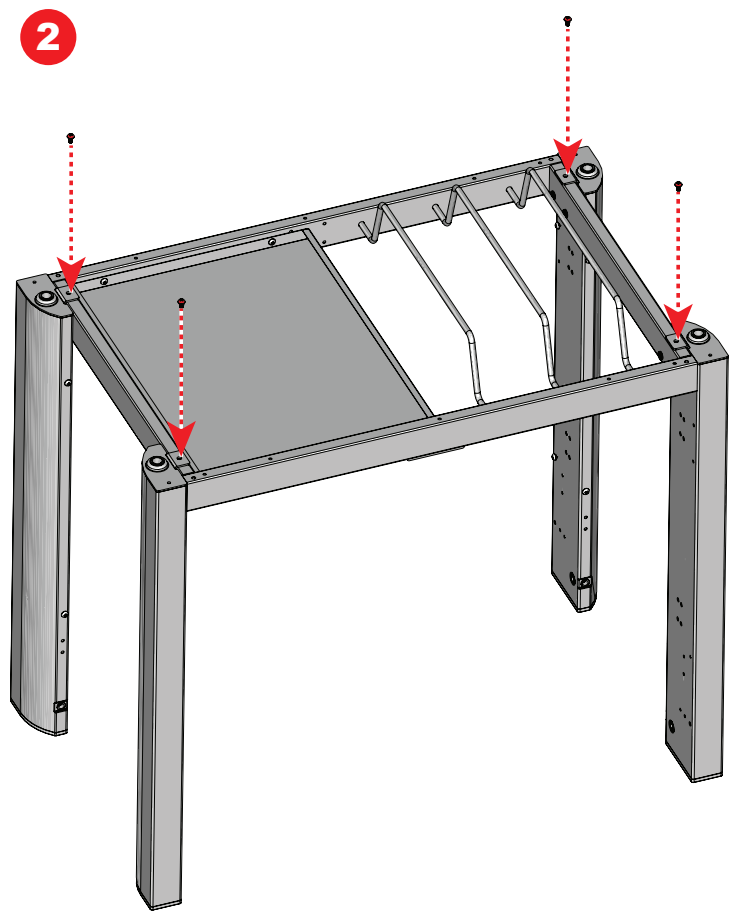
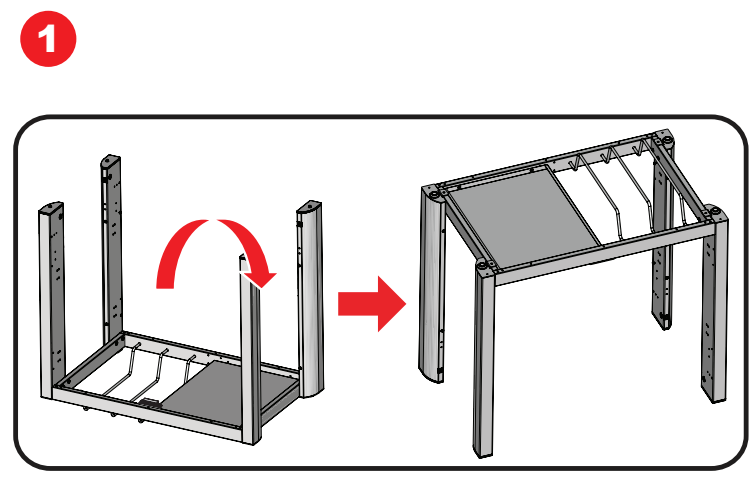
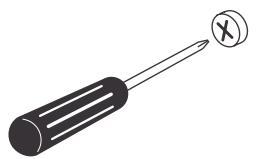
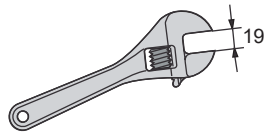
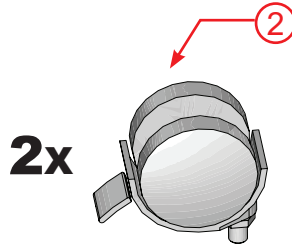
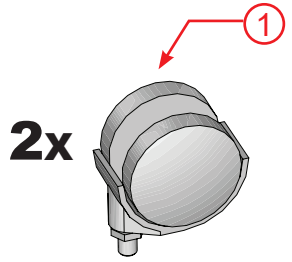

03

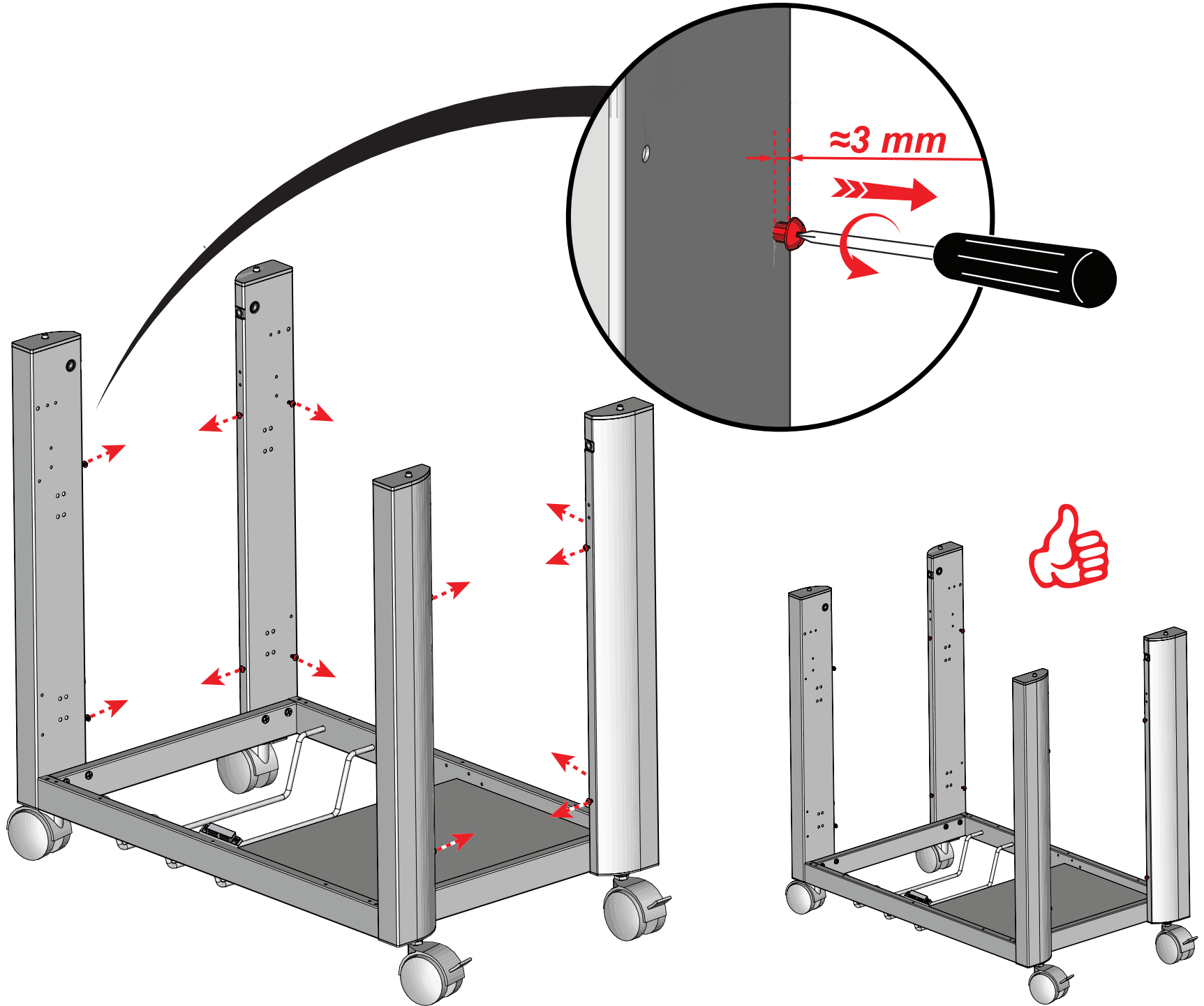
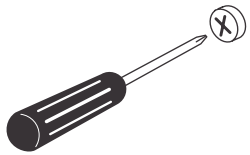

04

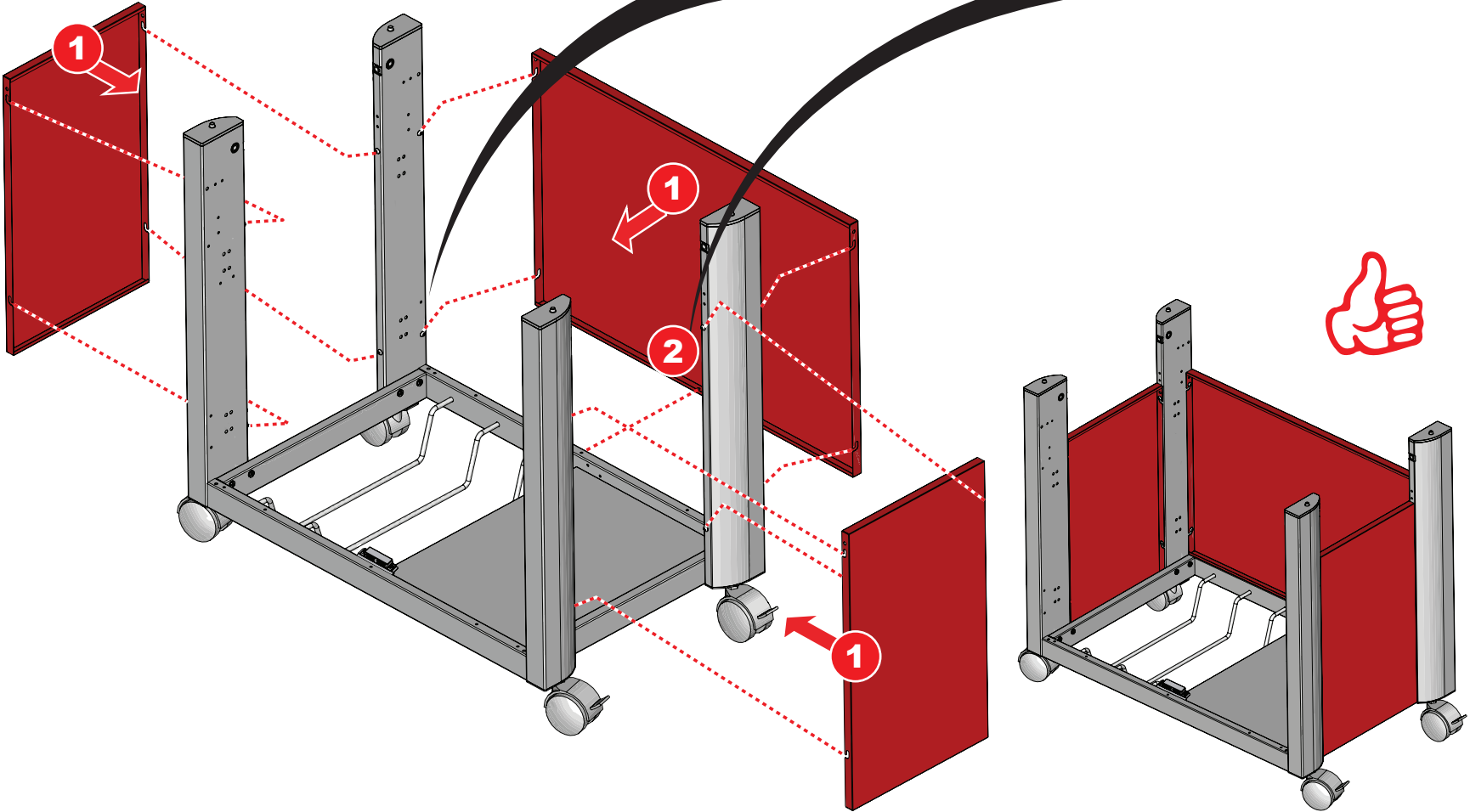
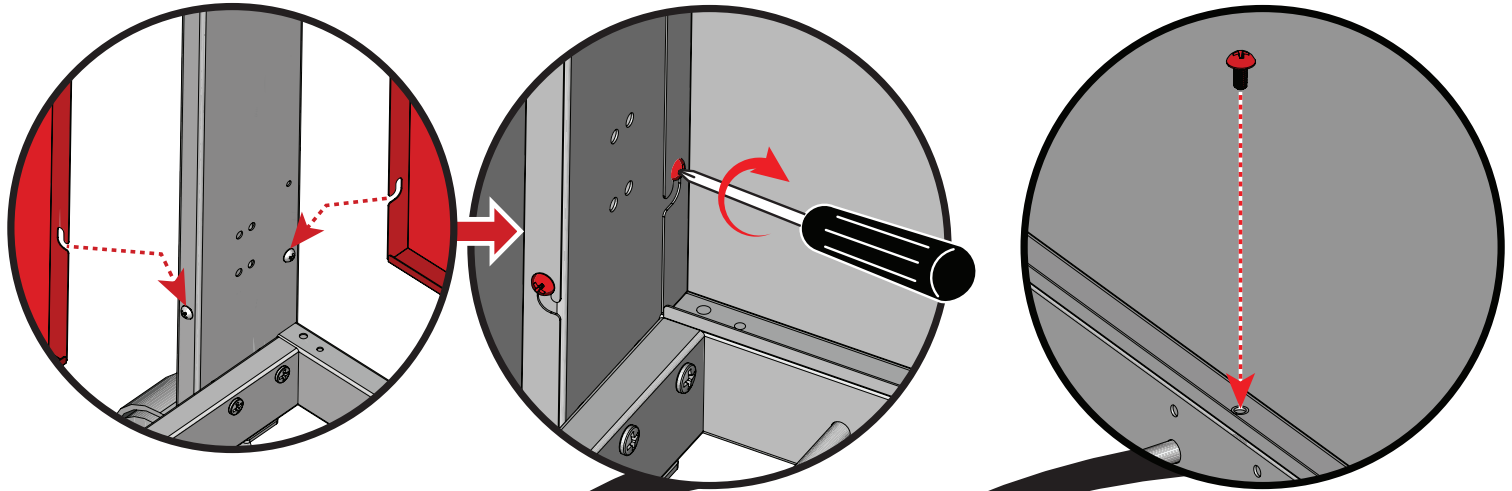
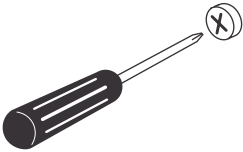
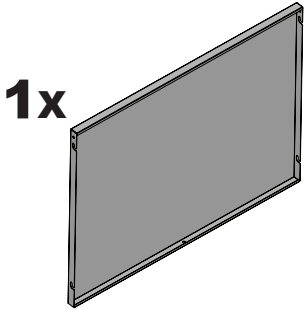
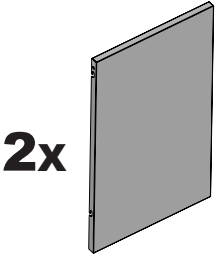

05

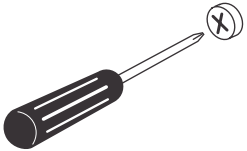
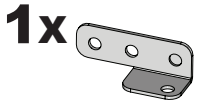
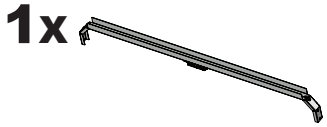

1

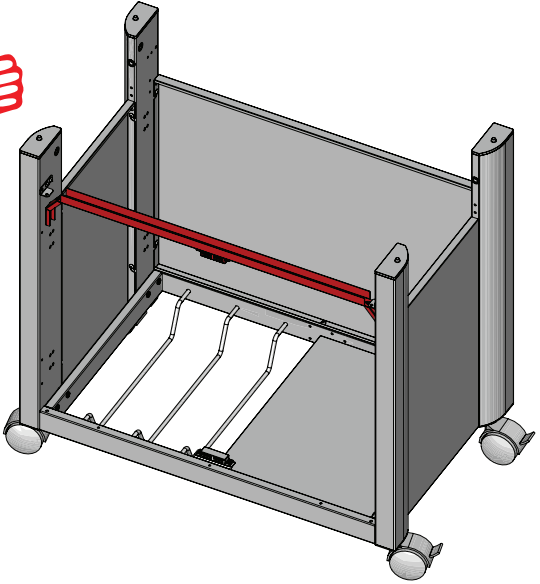
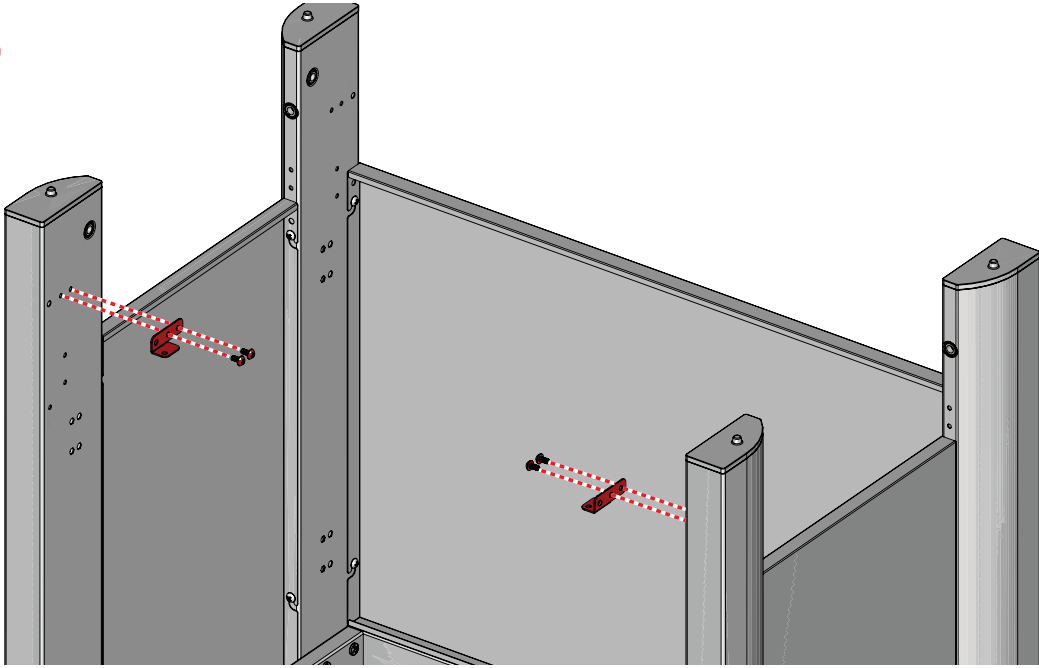

2

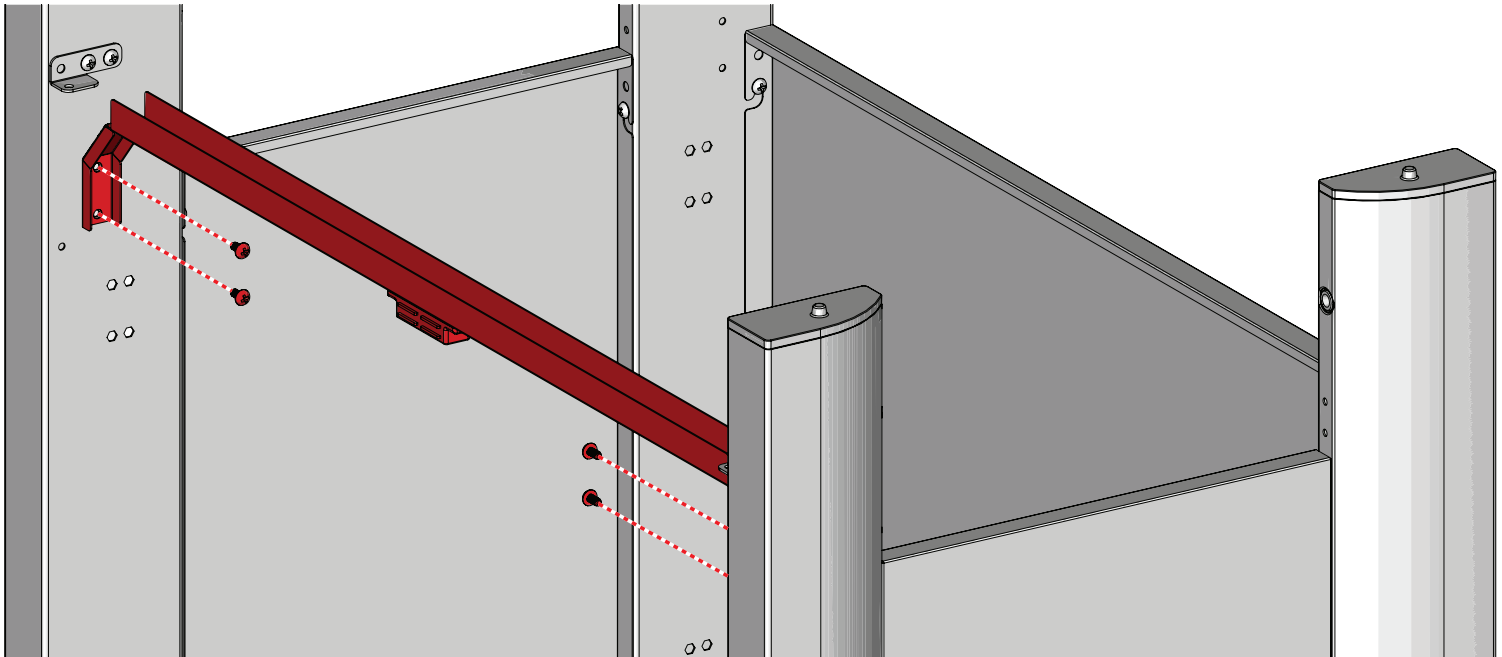

06

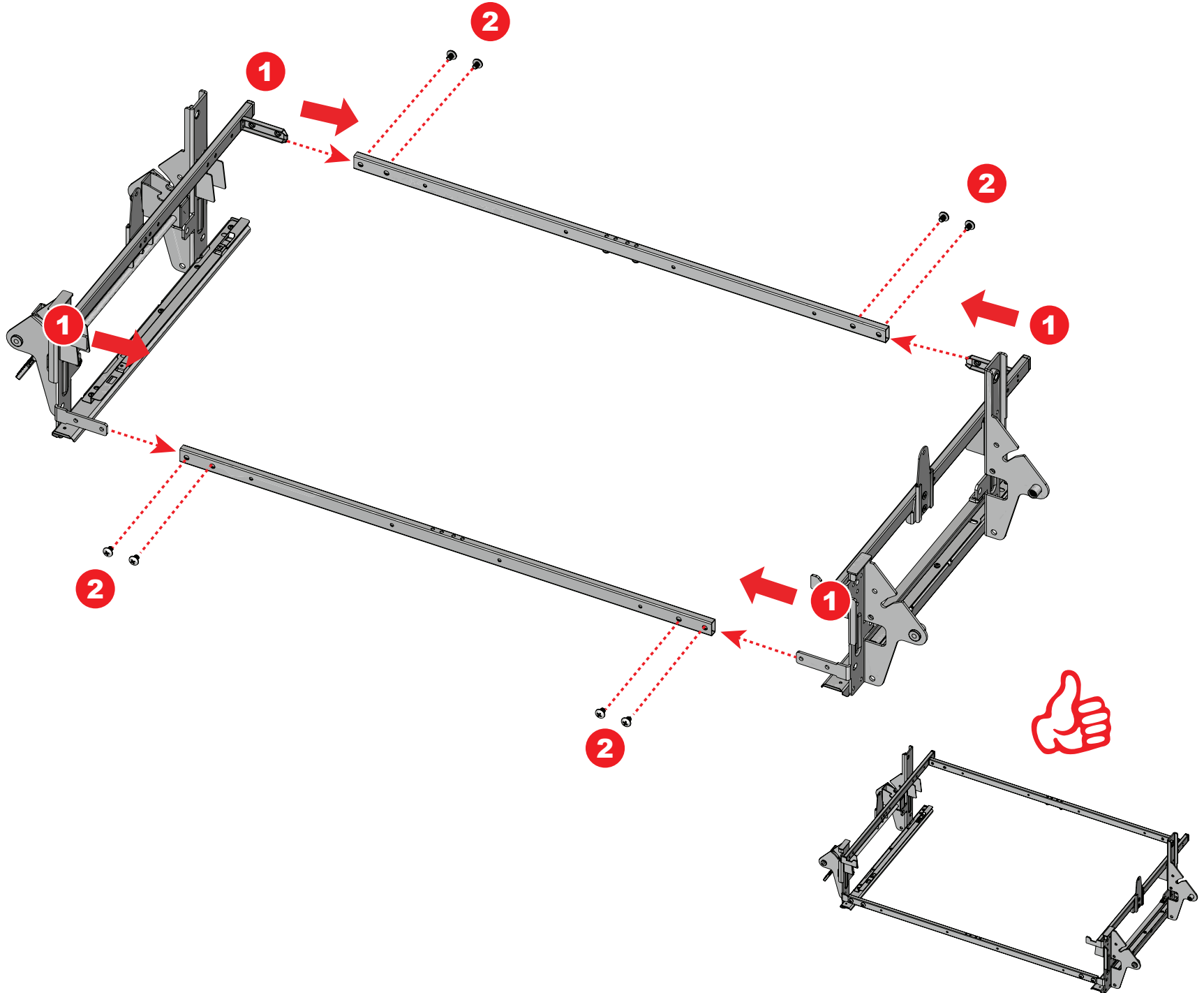
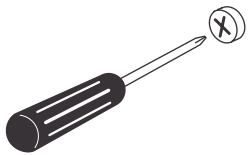
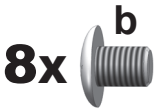
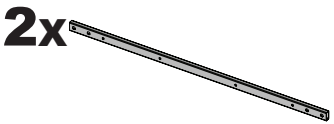
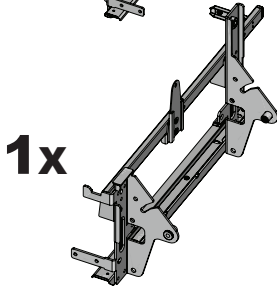
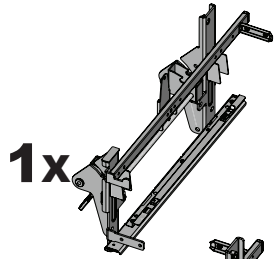

07

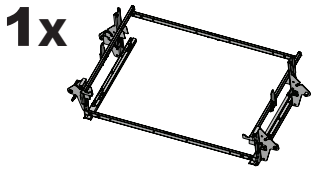

06

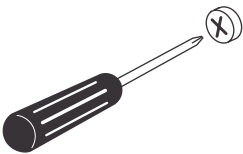
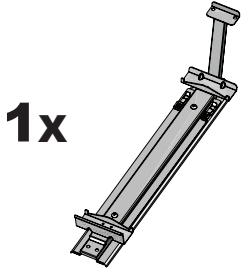

1

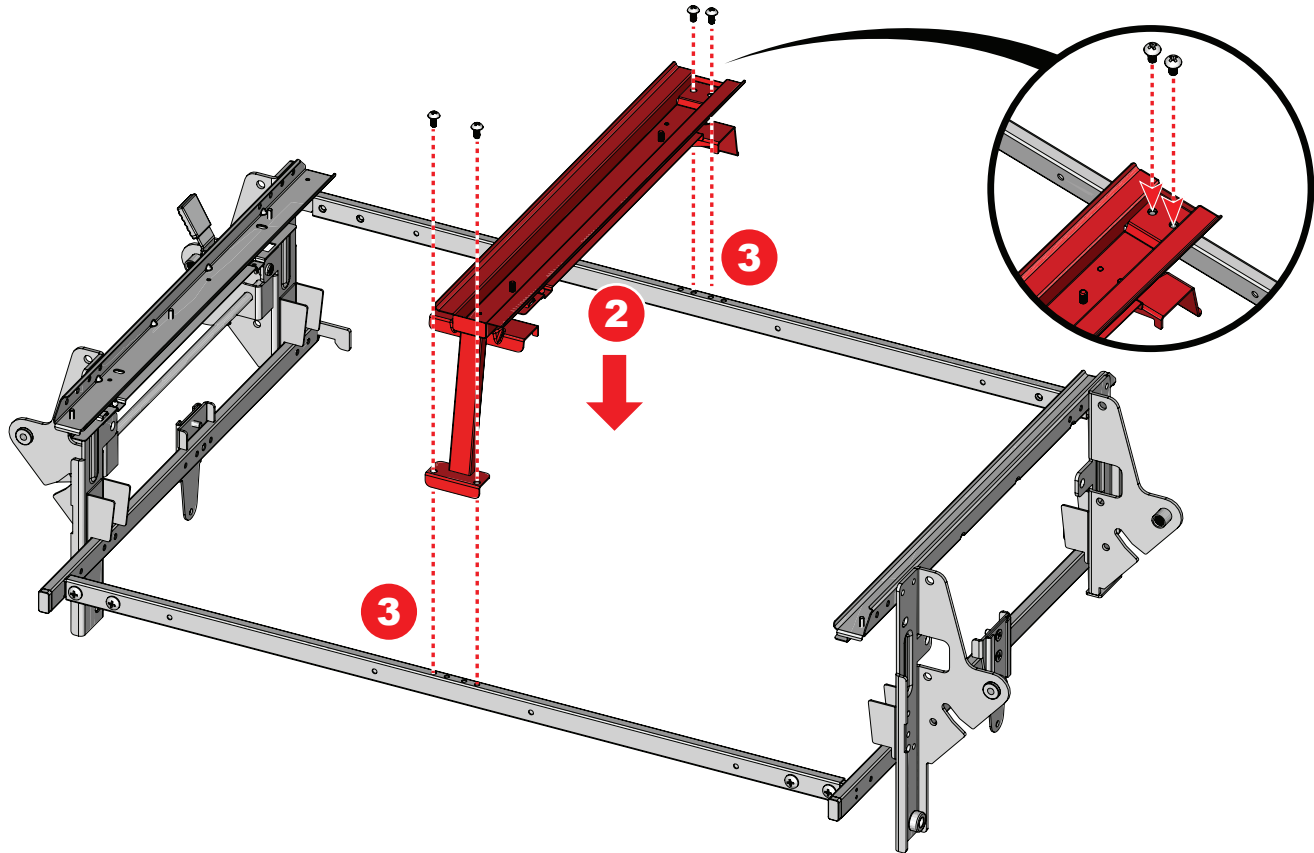
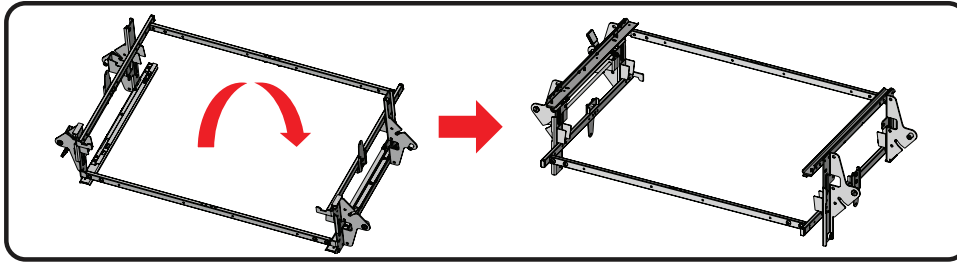
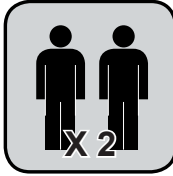

4

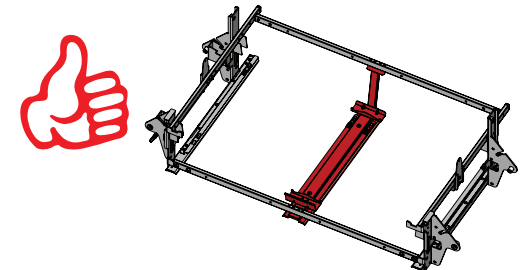
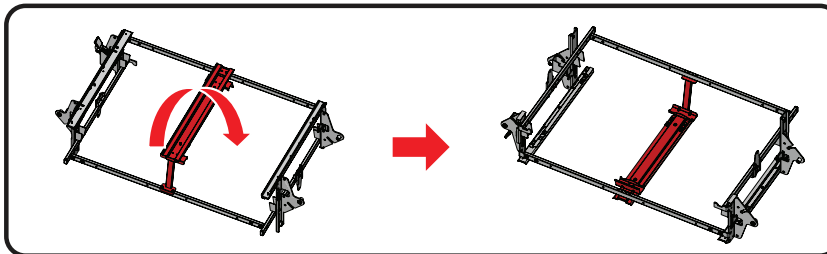
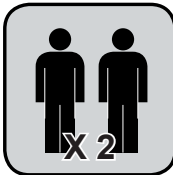

08

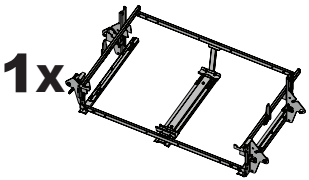

07

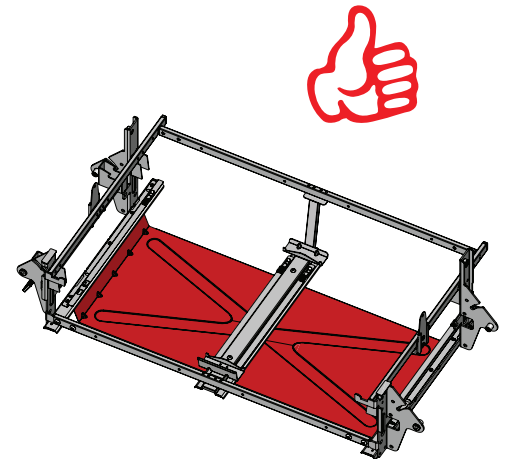
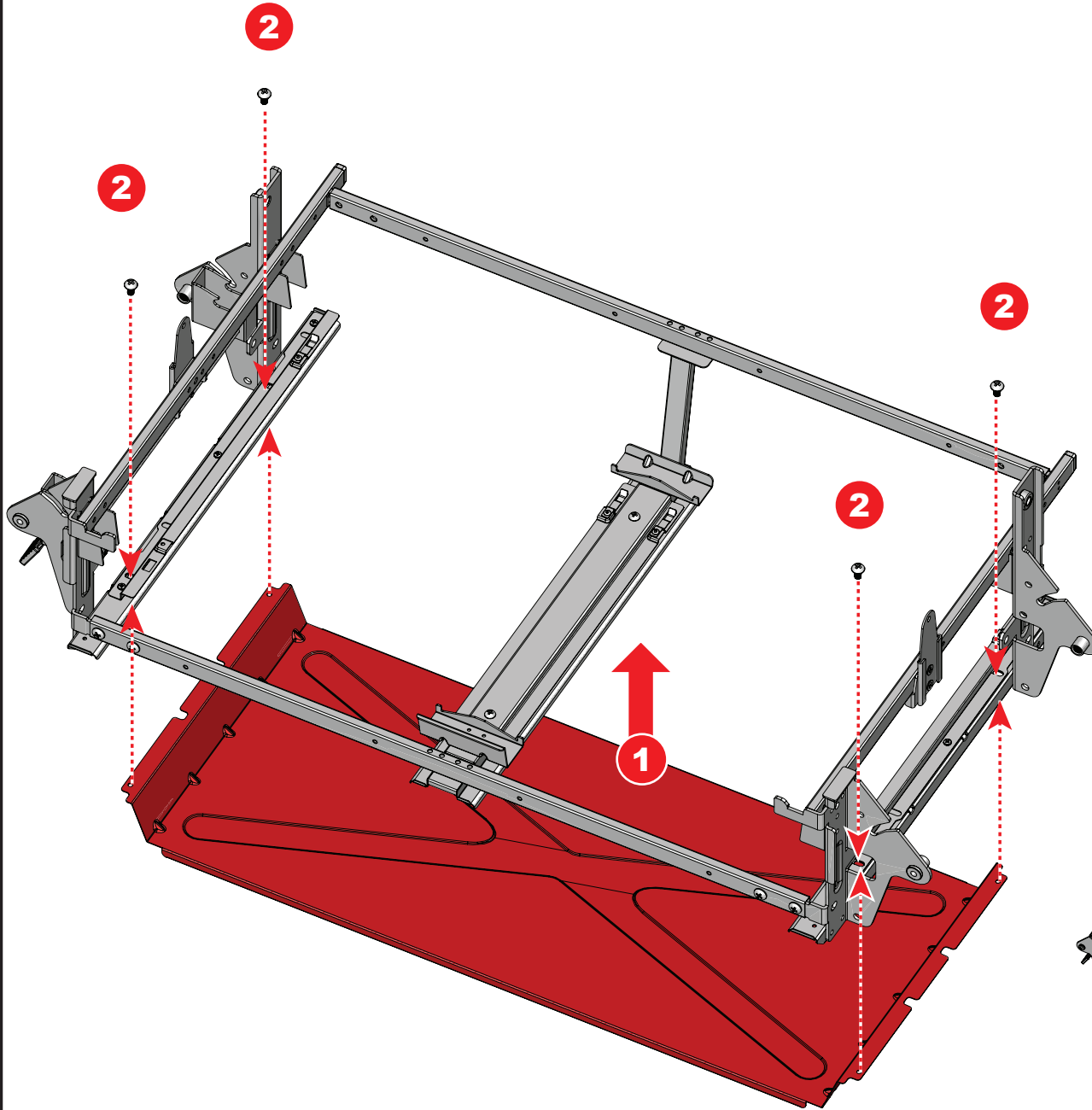
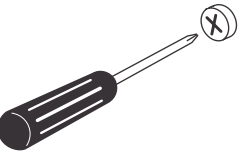
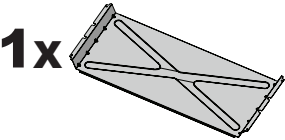

09

1x

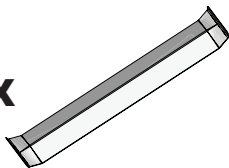

08

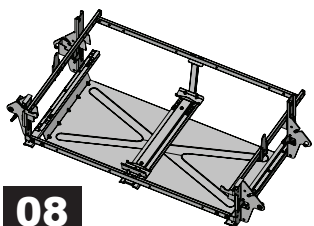

05

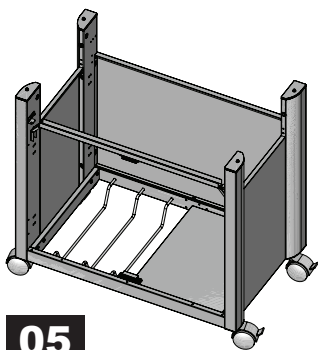

8x

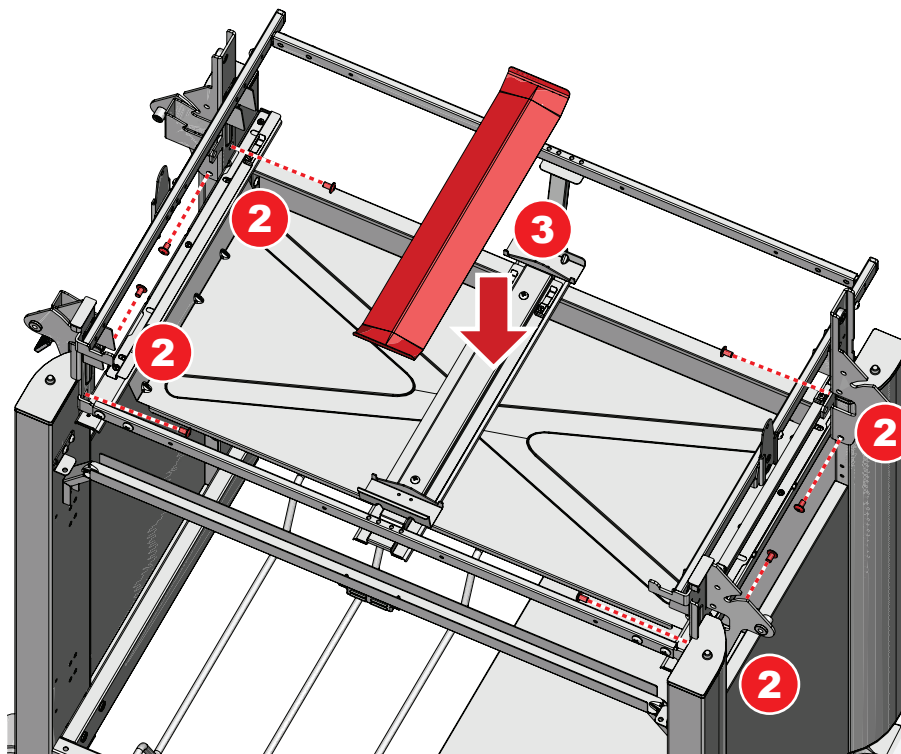
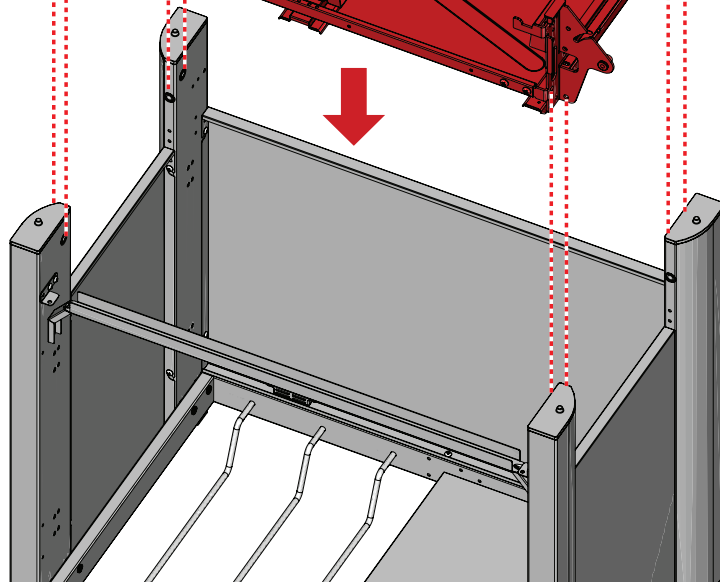
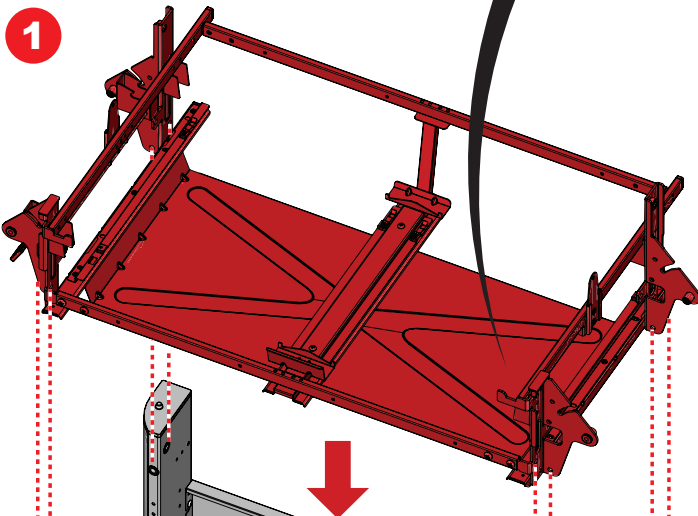
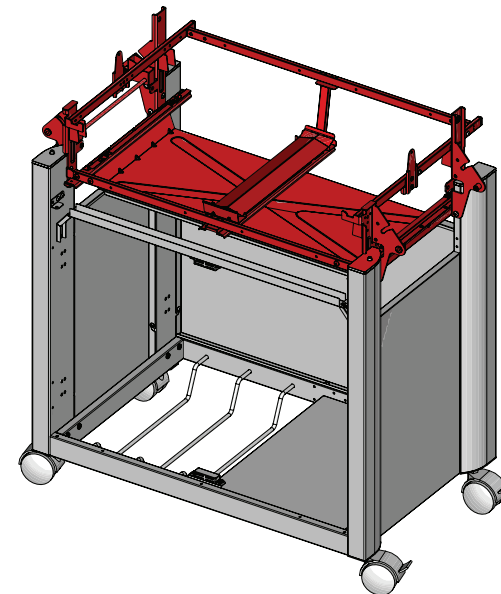
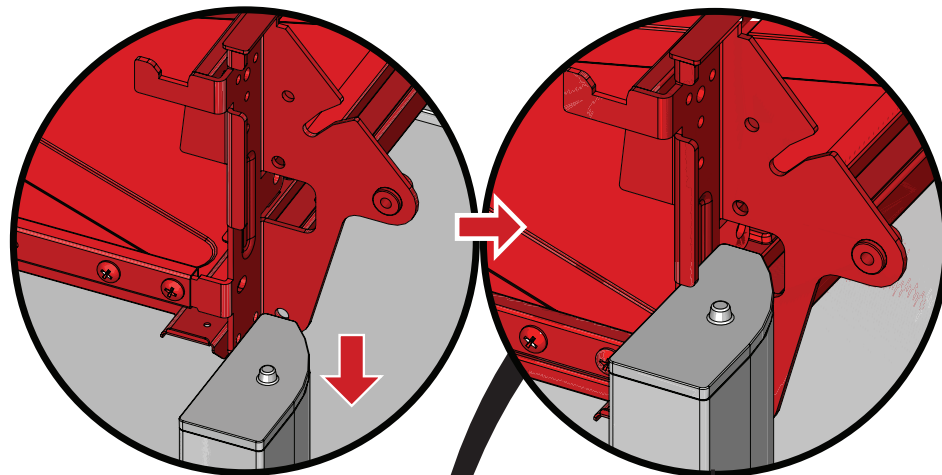
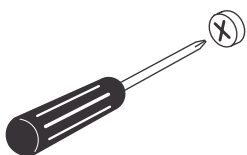
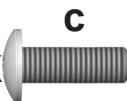

10

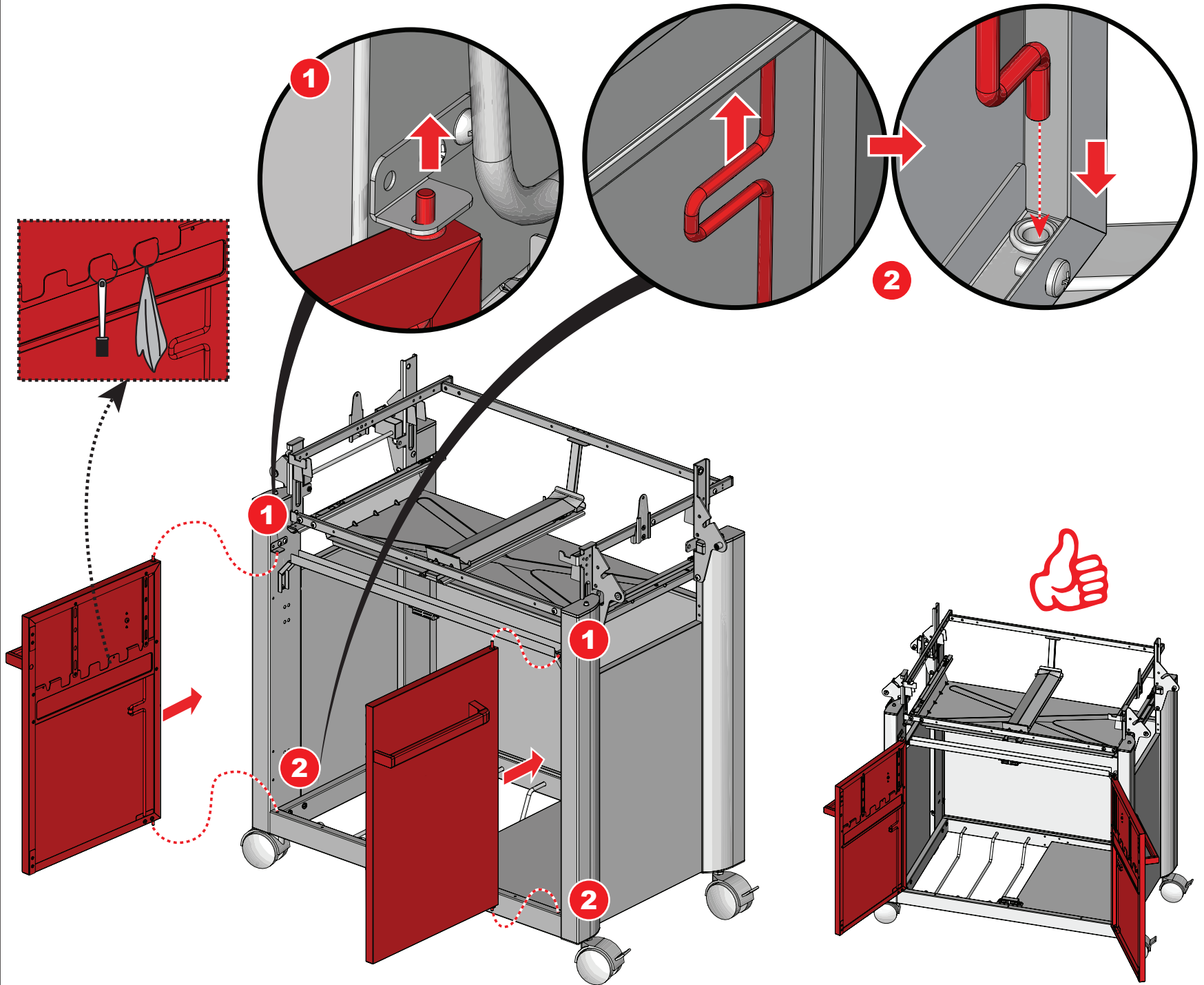
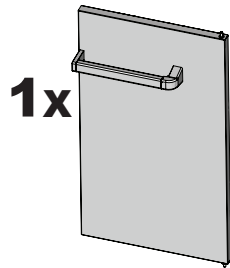
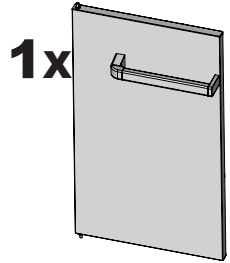

10A

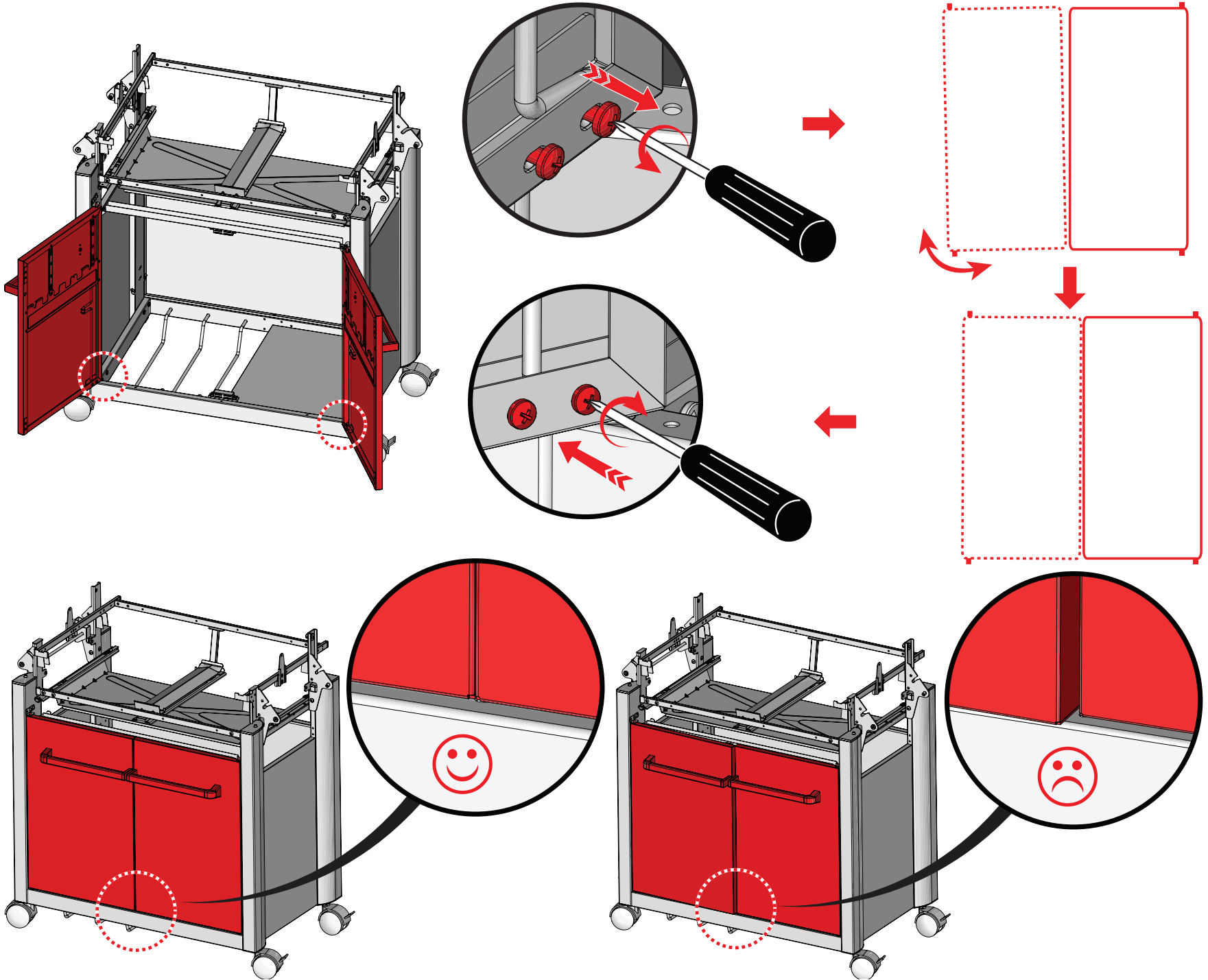
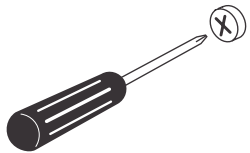

11

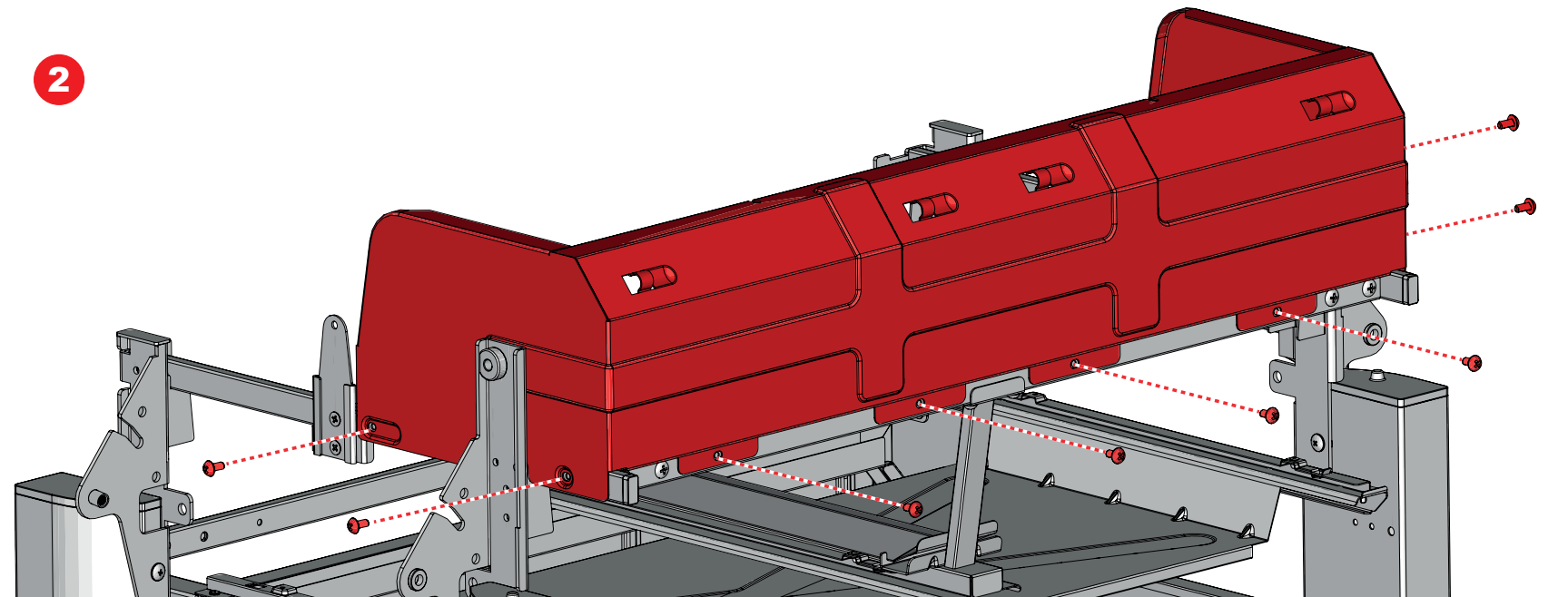
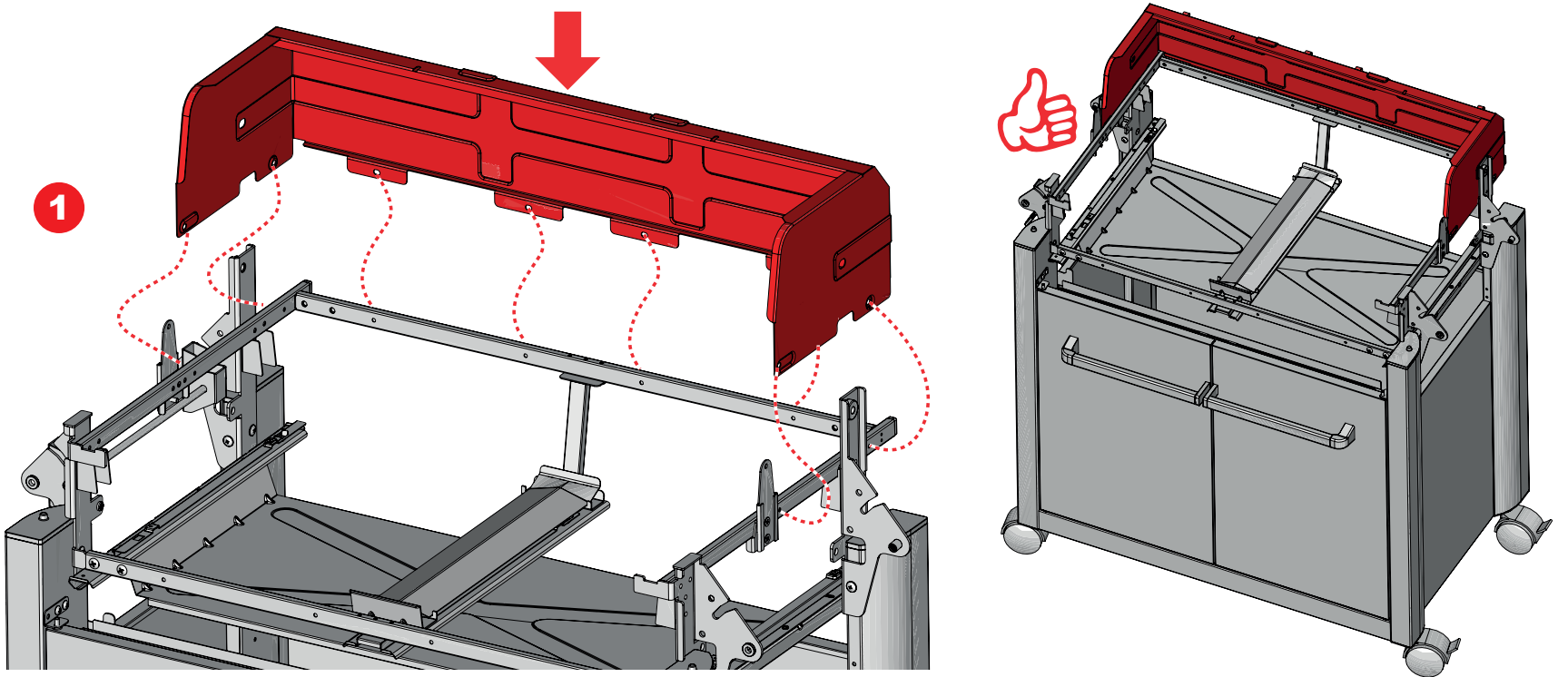
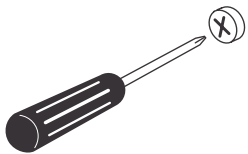
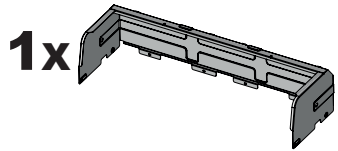

12

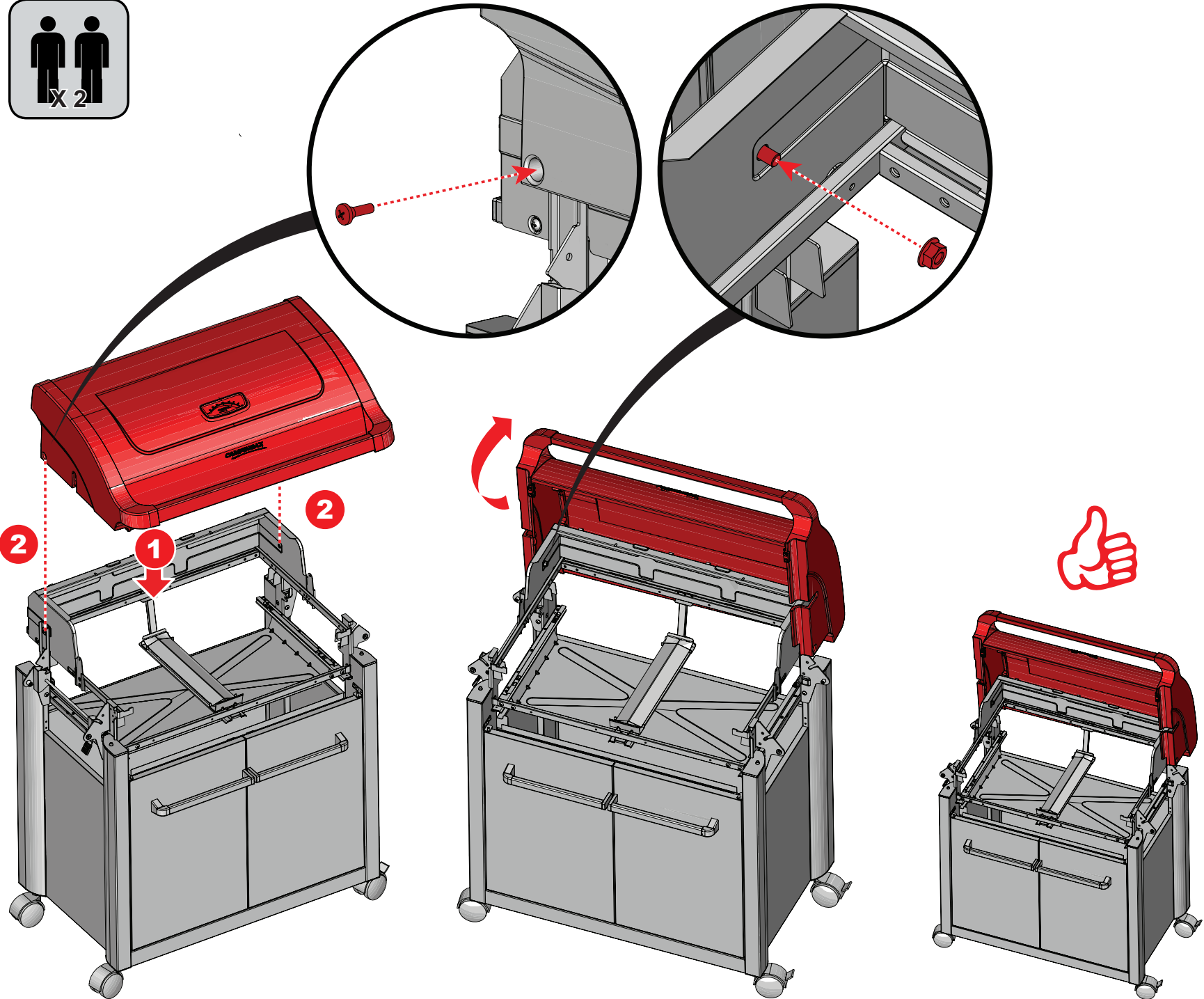
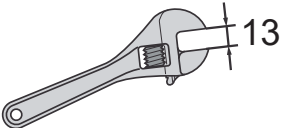
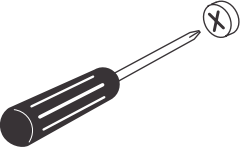
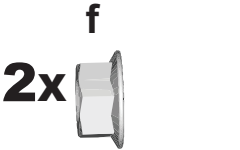
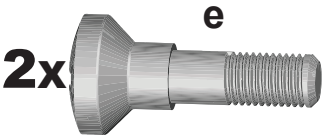

13A

1x 

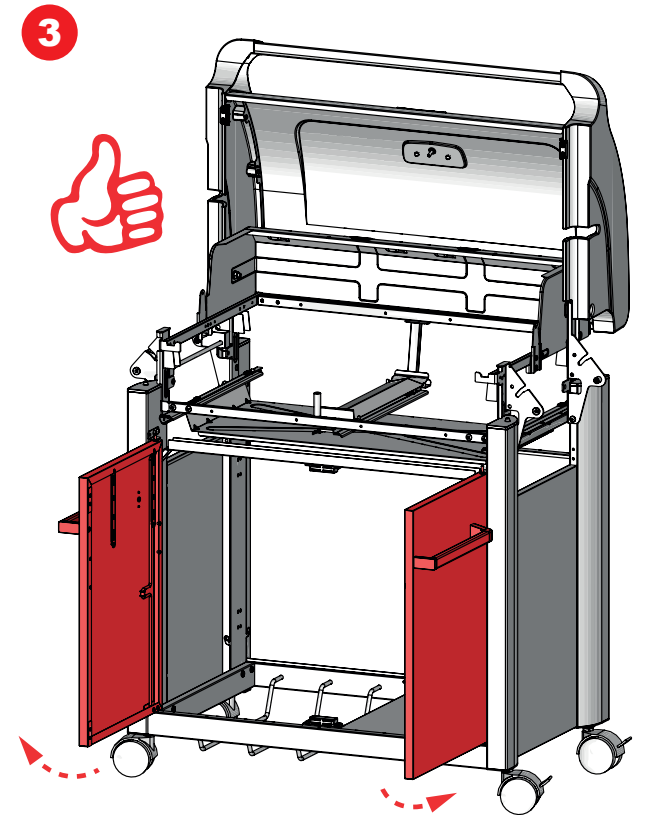
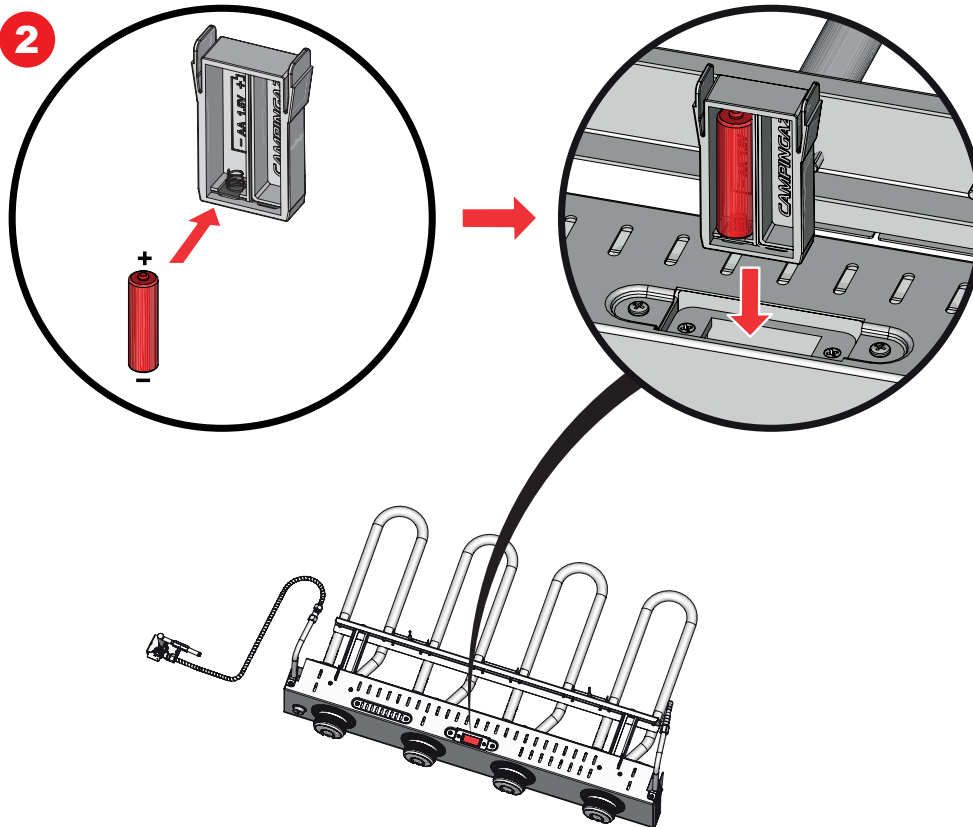
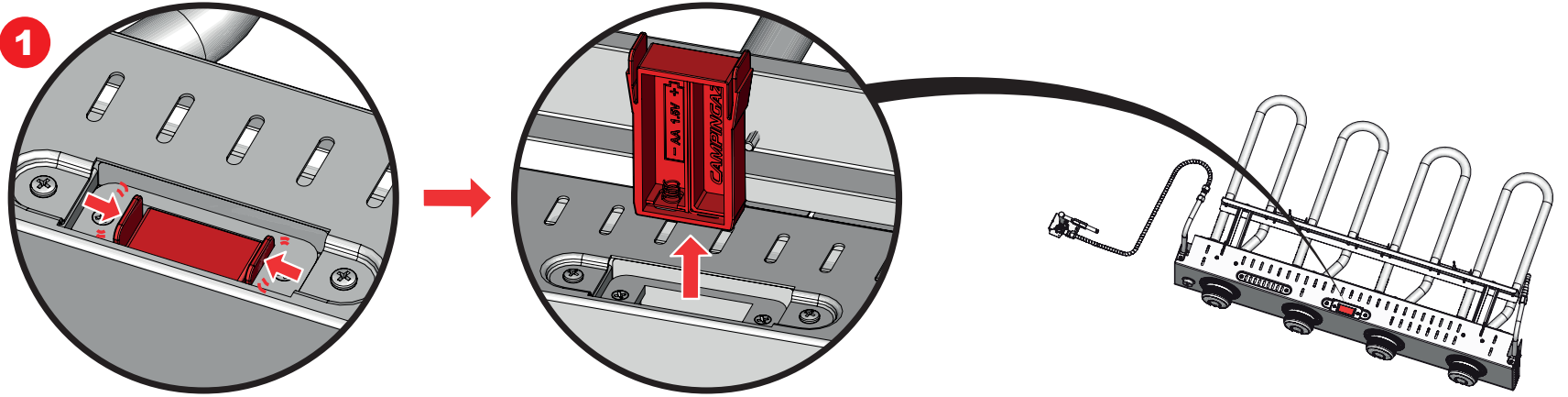

13B

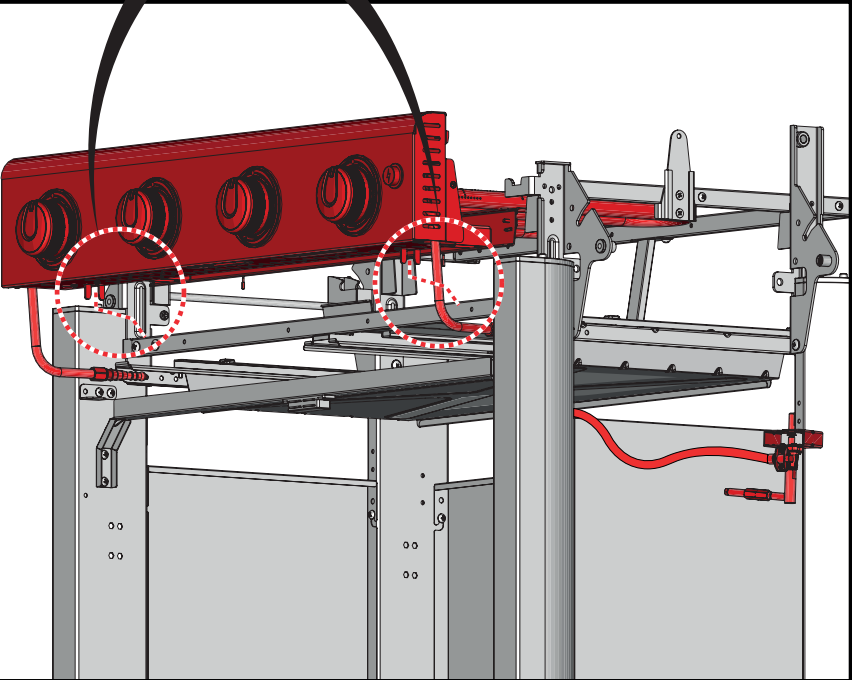
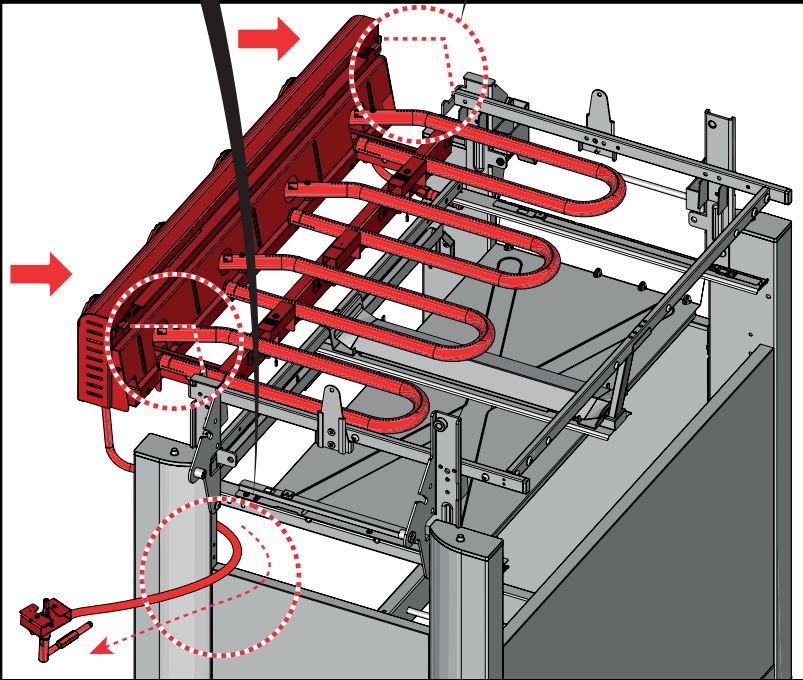
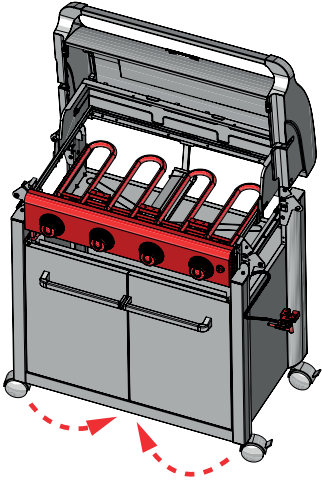
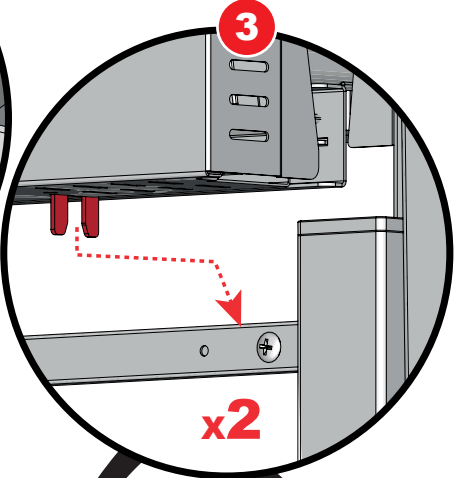
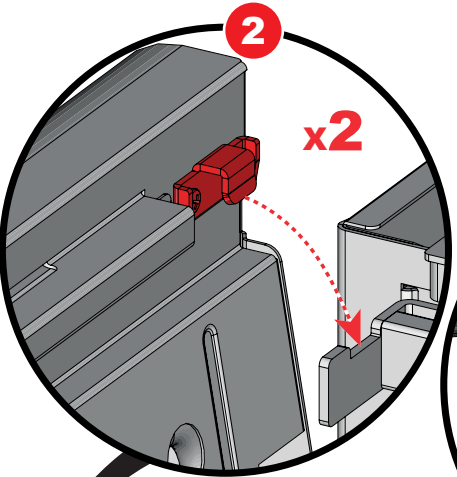
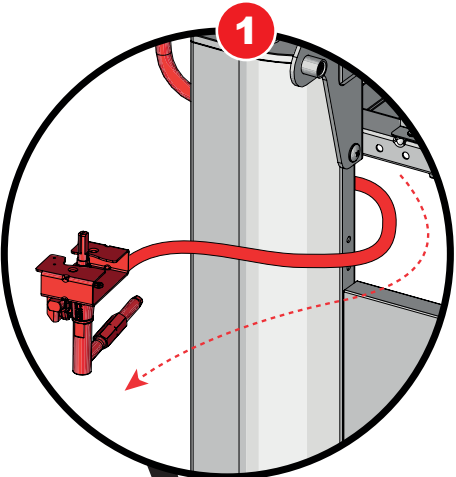
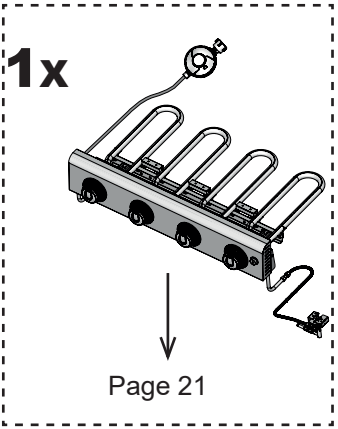
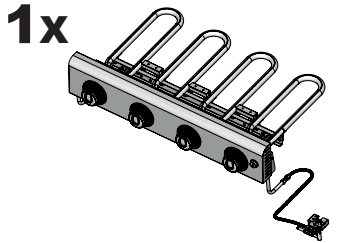

13B

1x

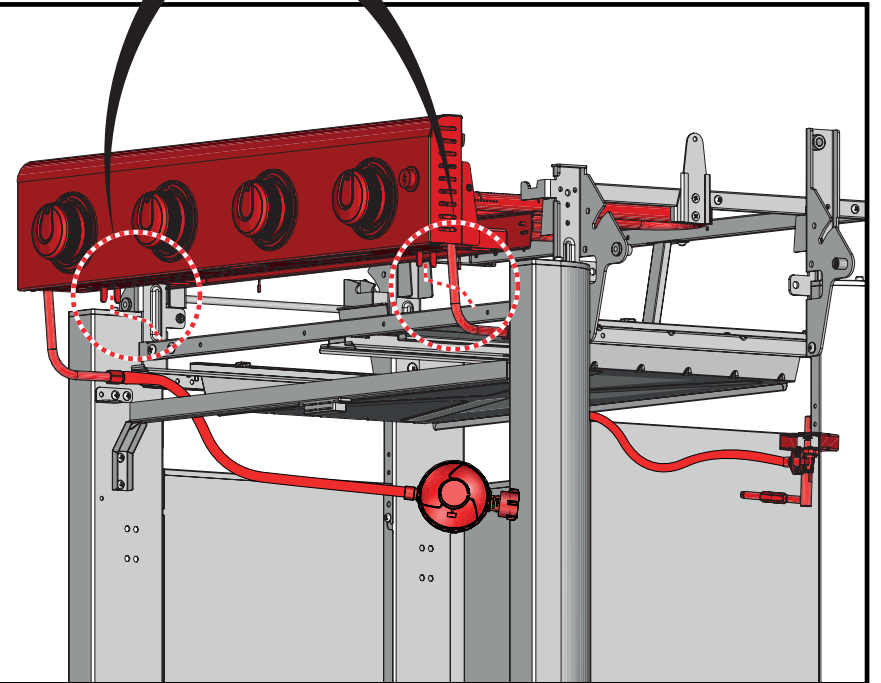
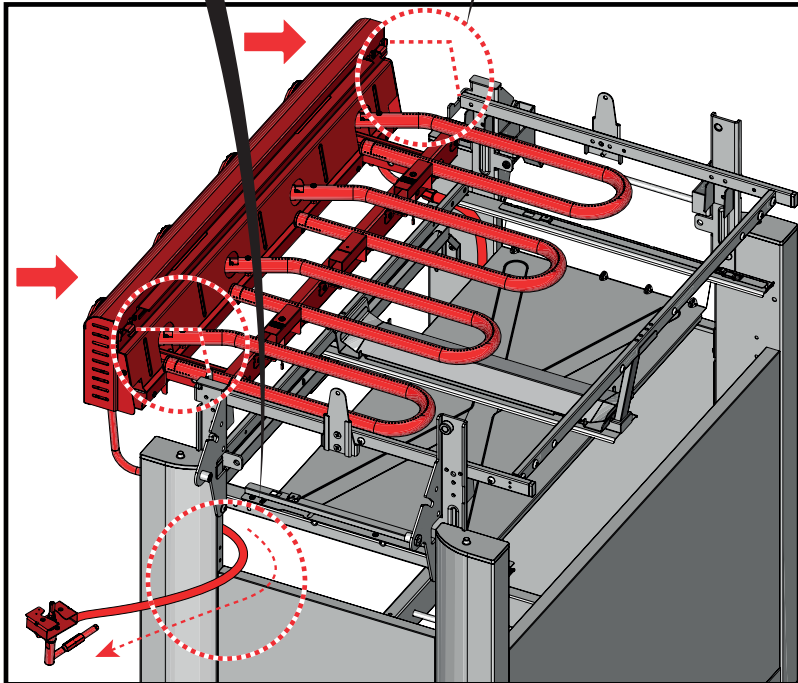
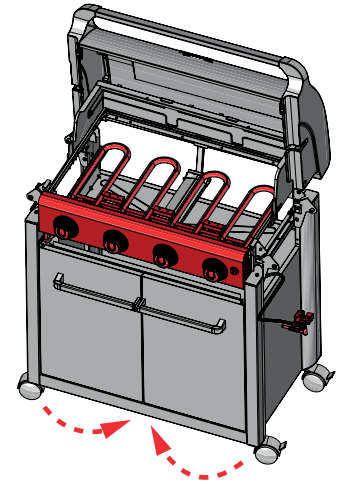
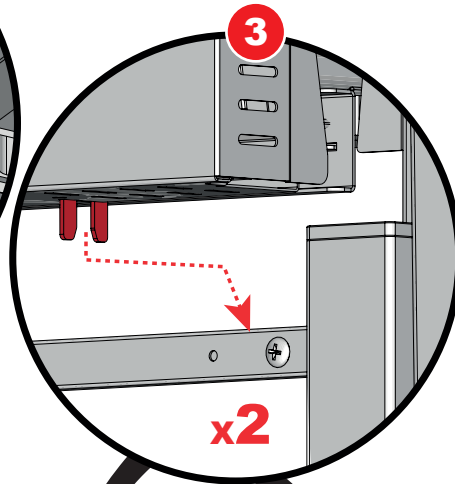
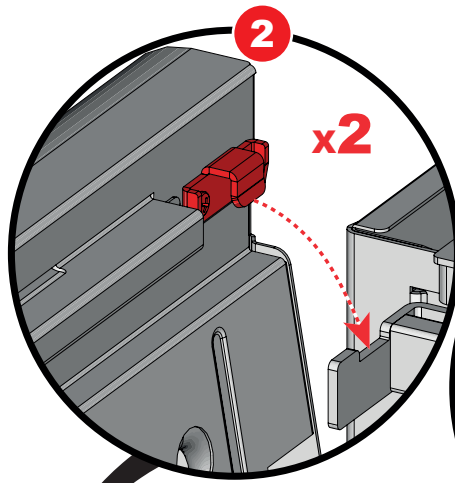
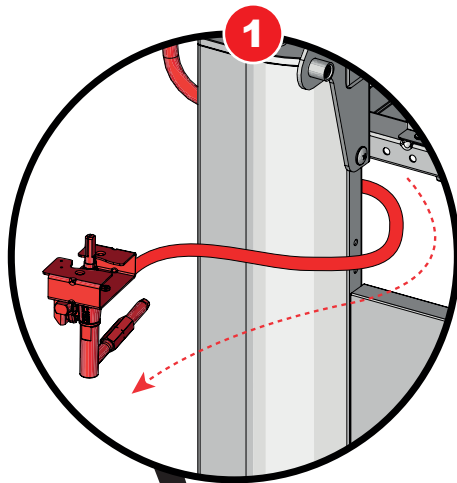
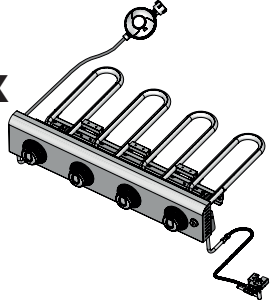

14

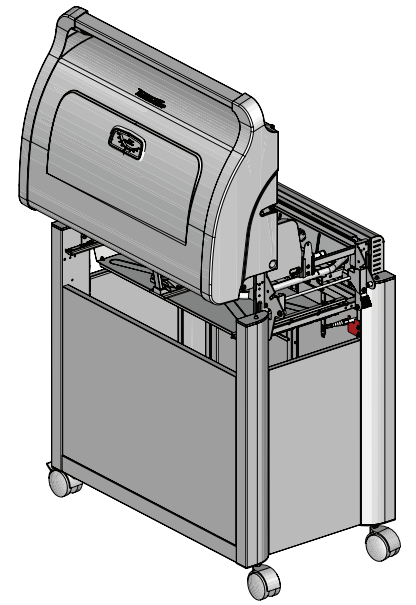
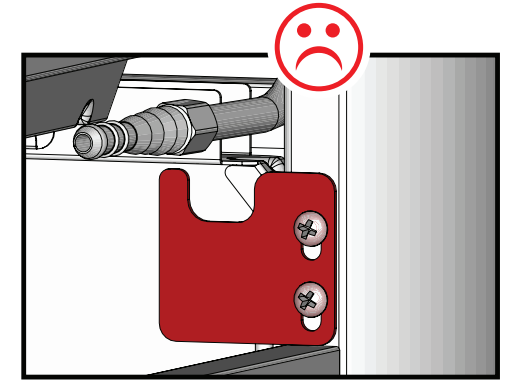
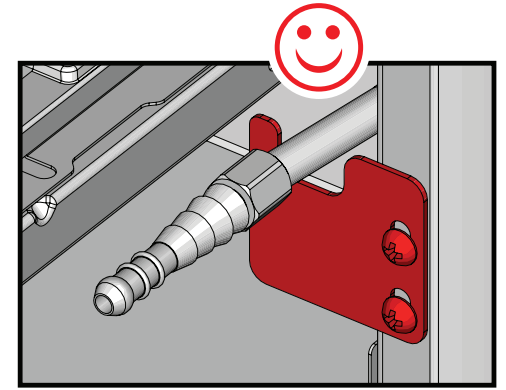
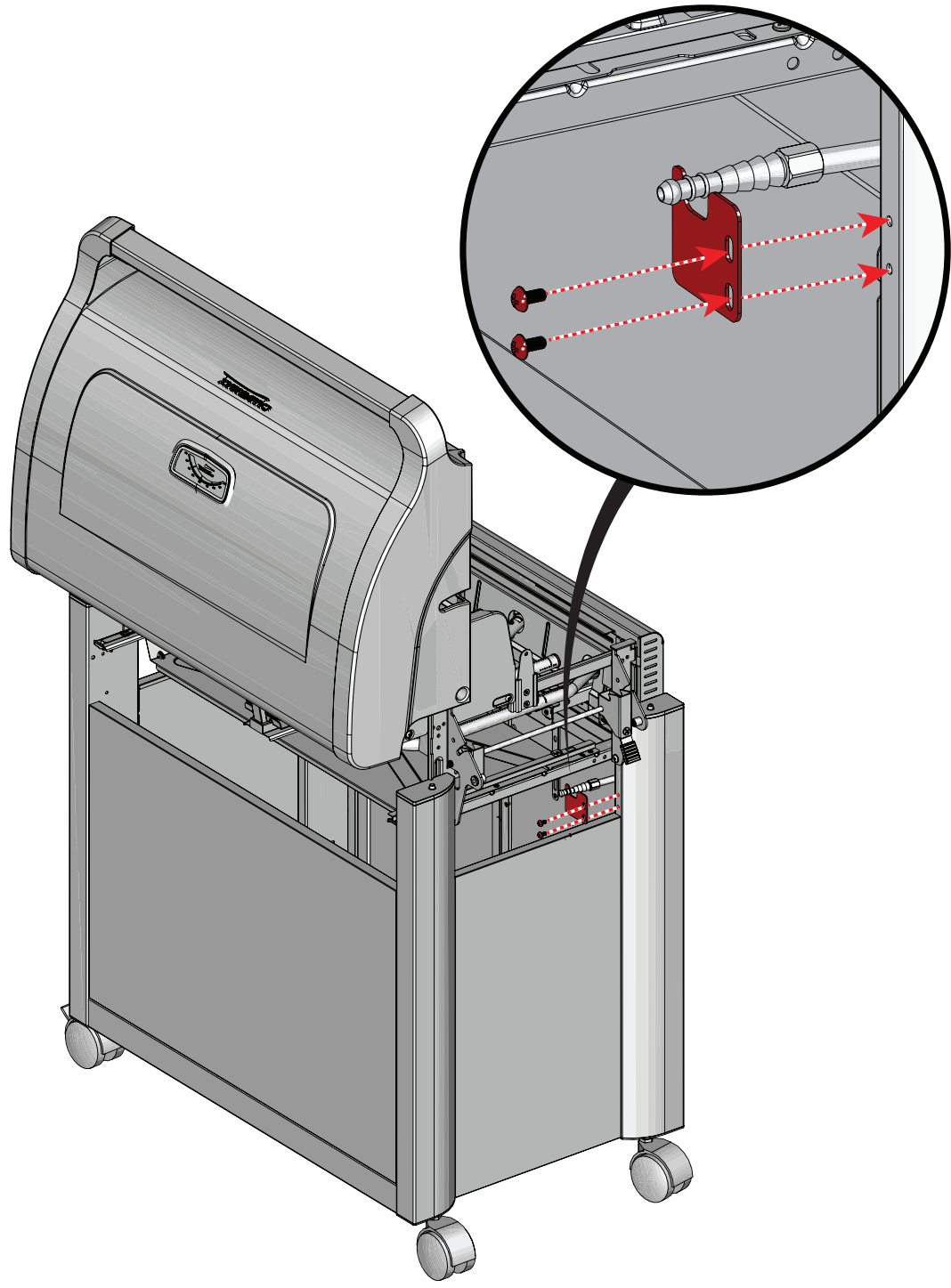
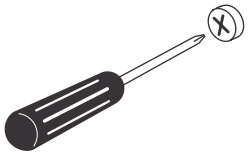
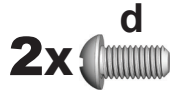
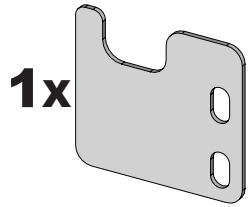

15

1x

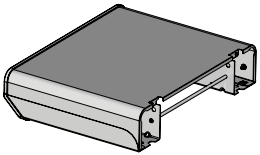

2x

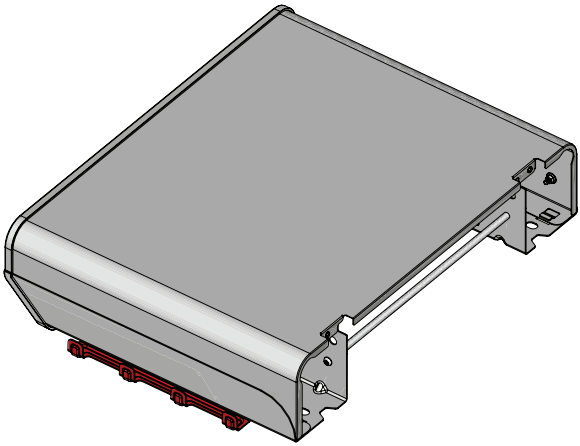
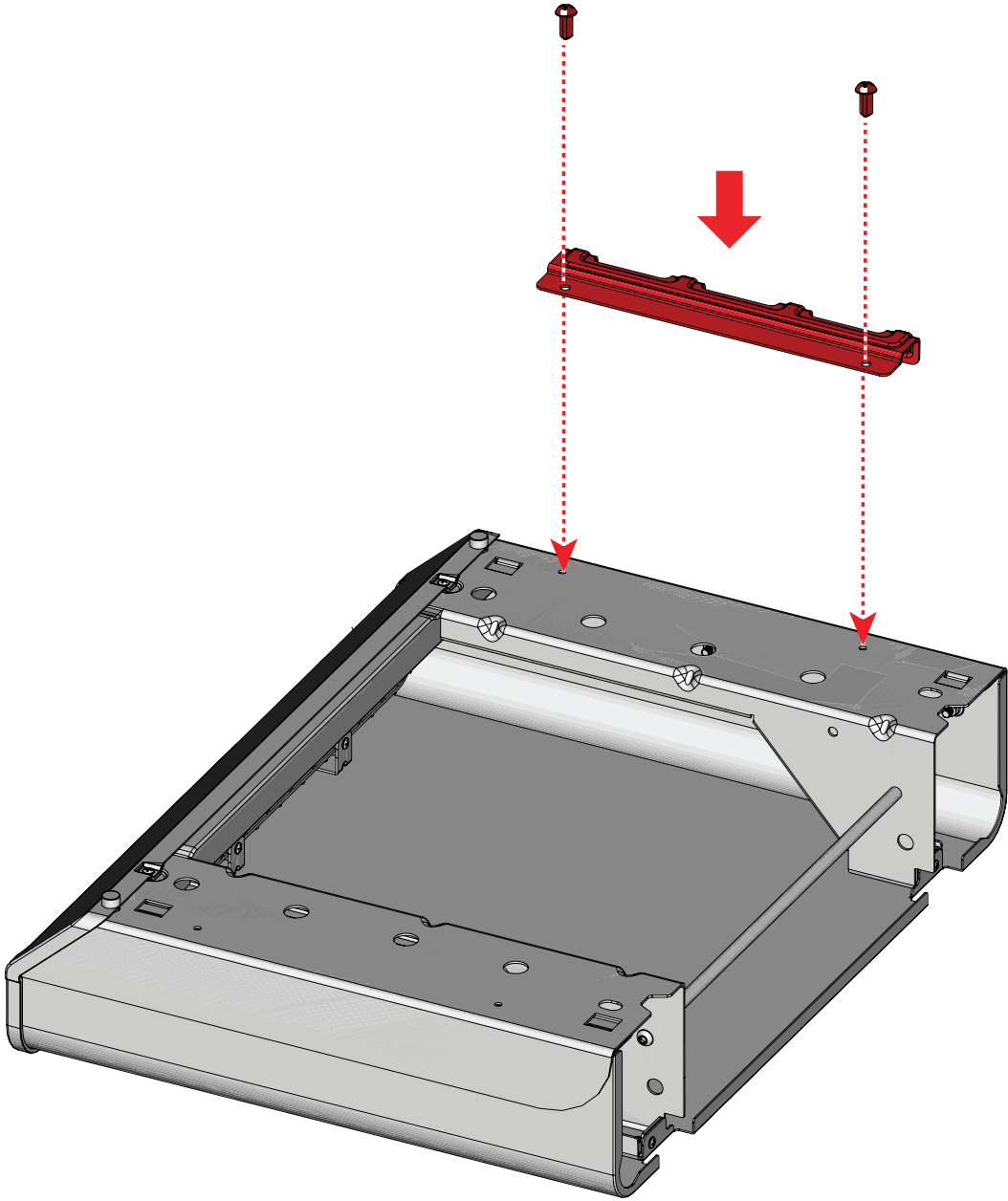
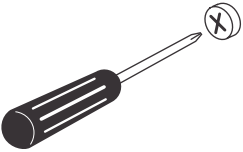
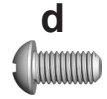

16

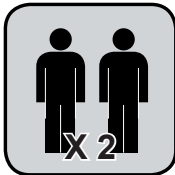

1x

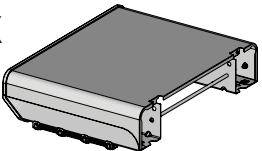

1x

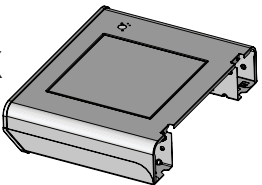

4x

g

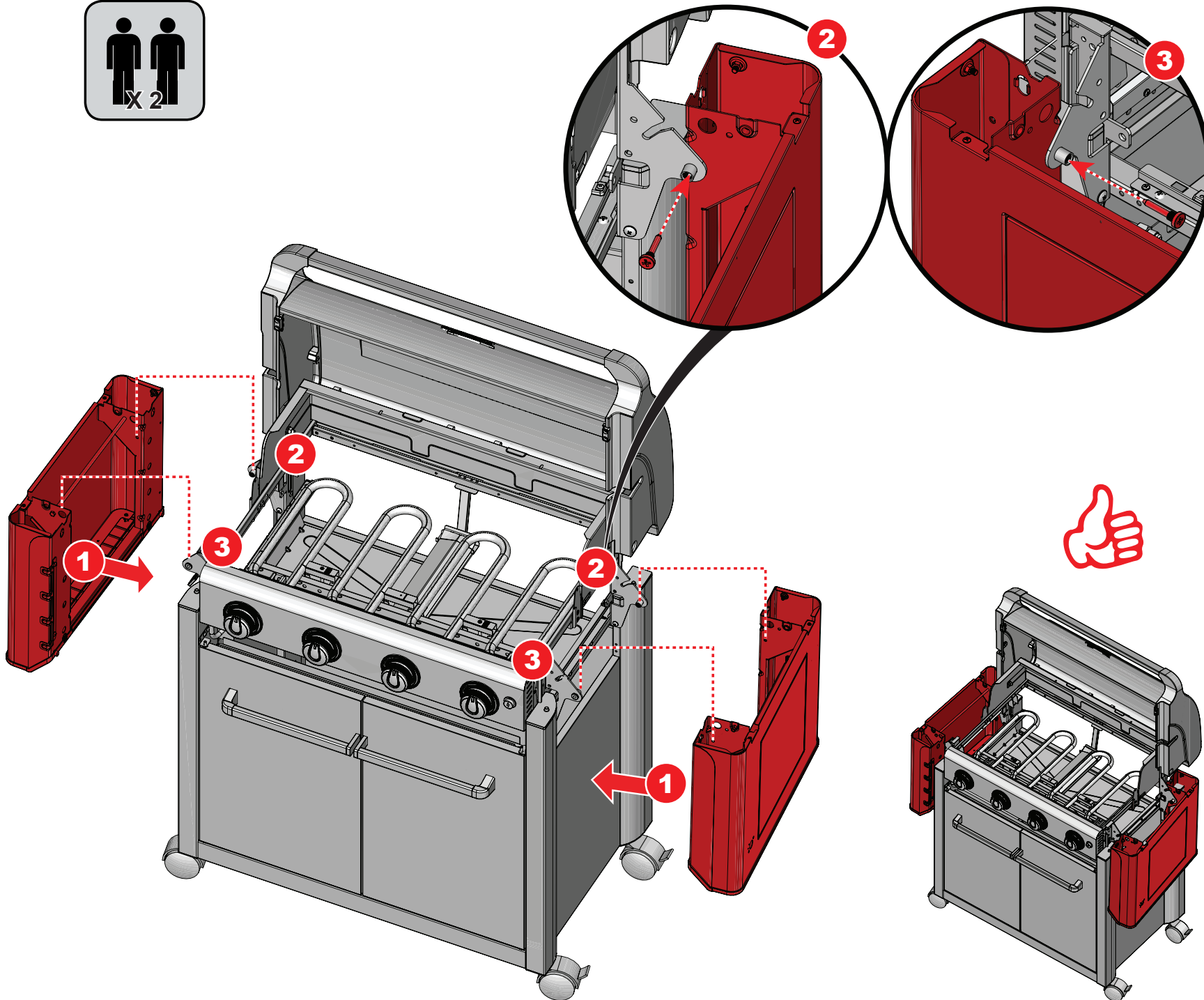
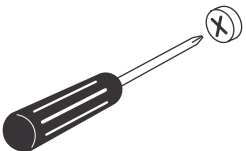

17

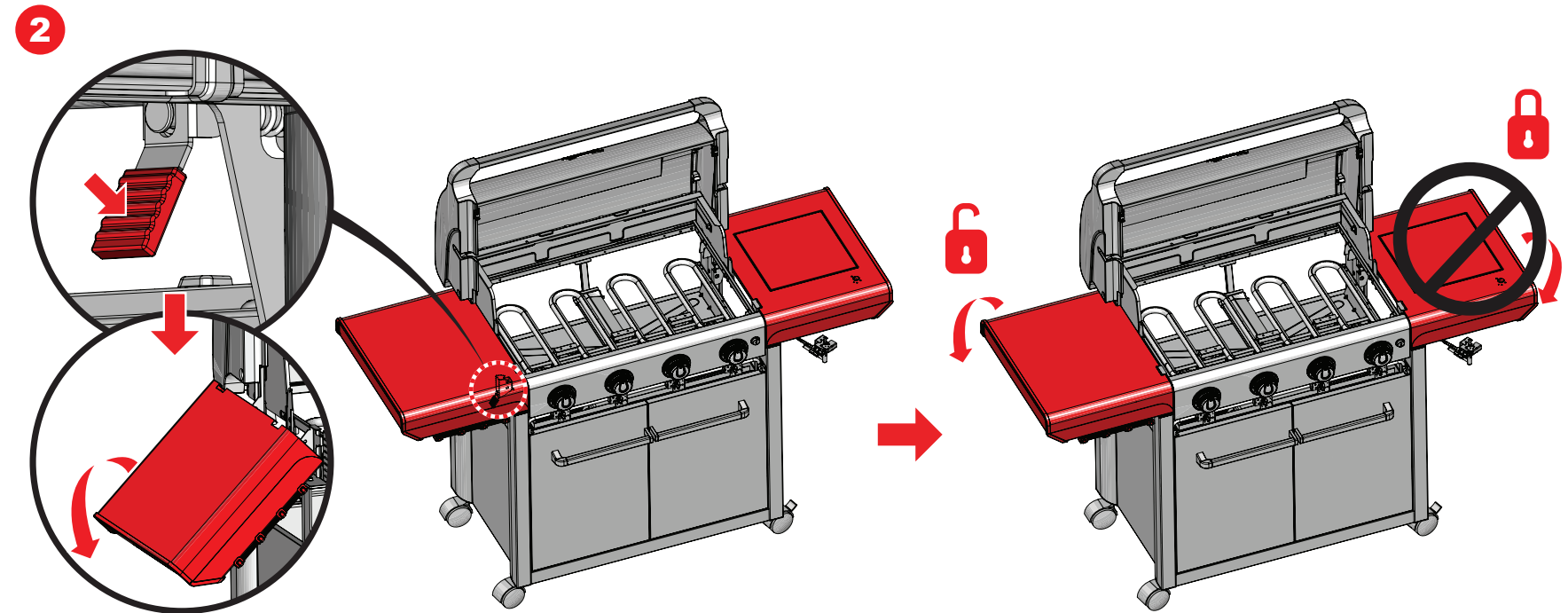
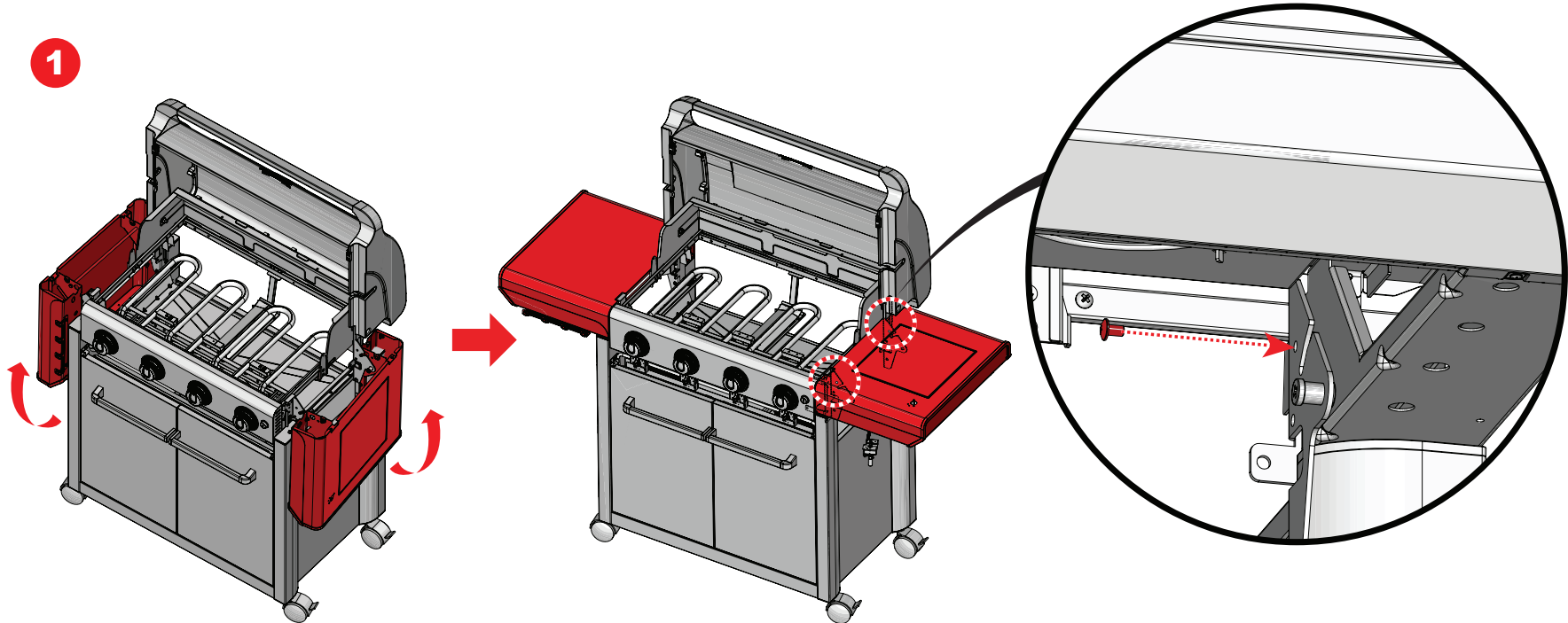
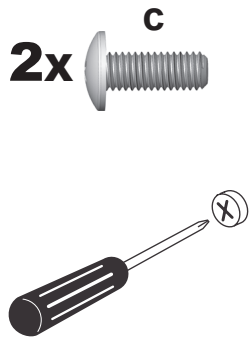

18

2x ^d

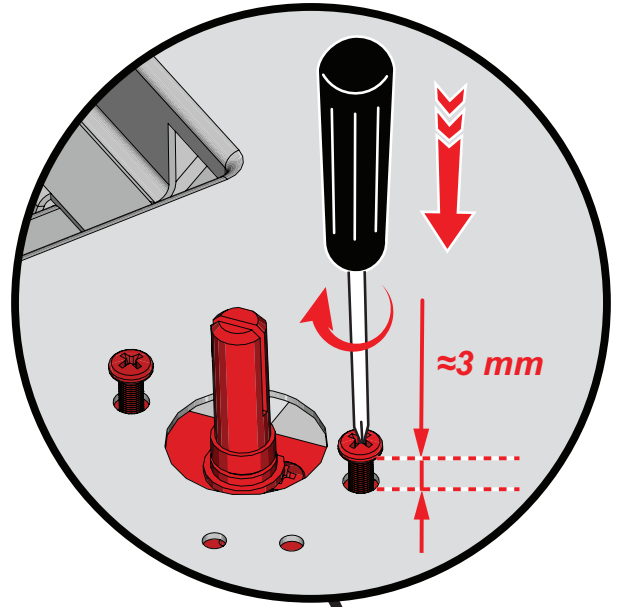
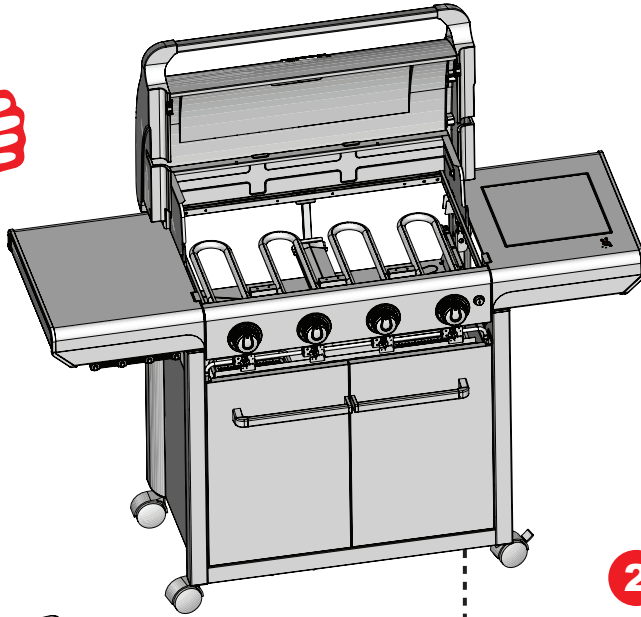
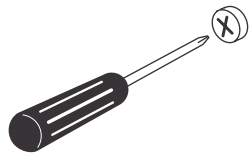

1

2

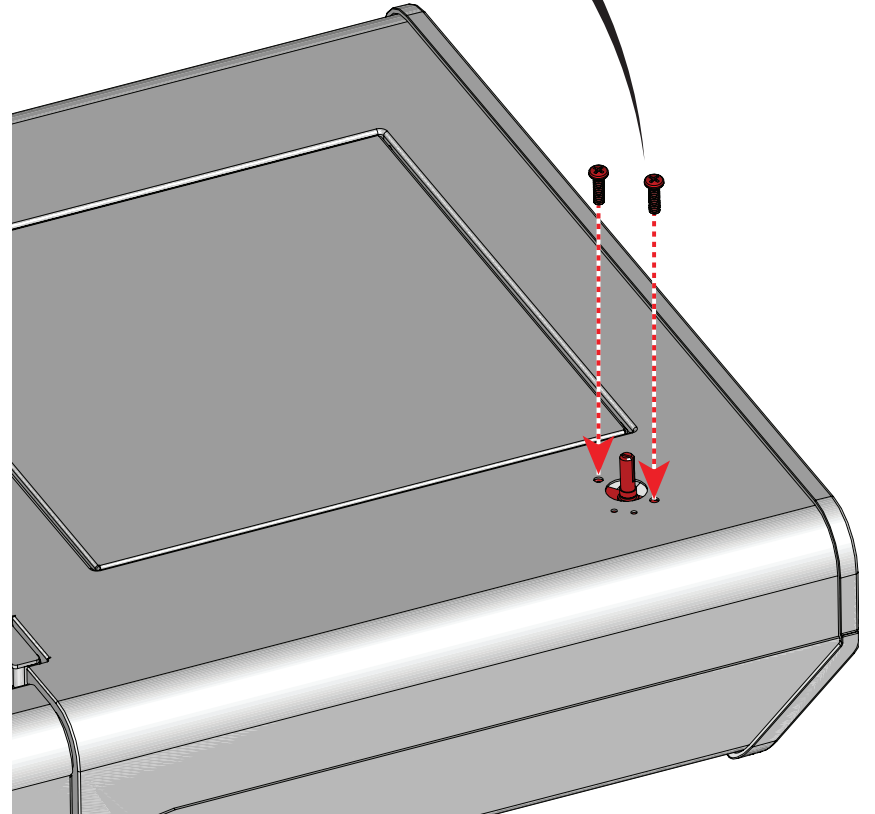
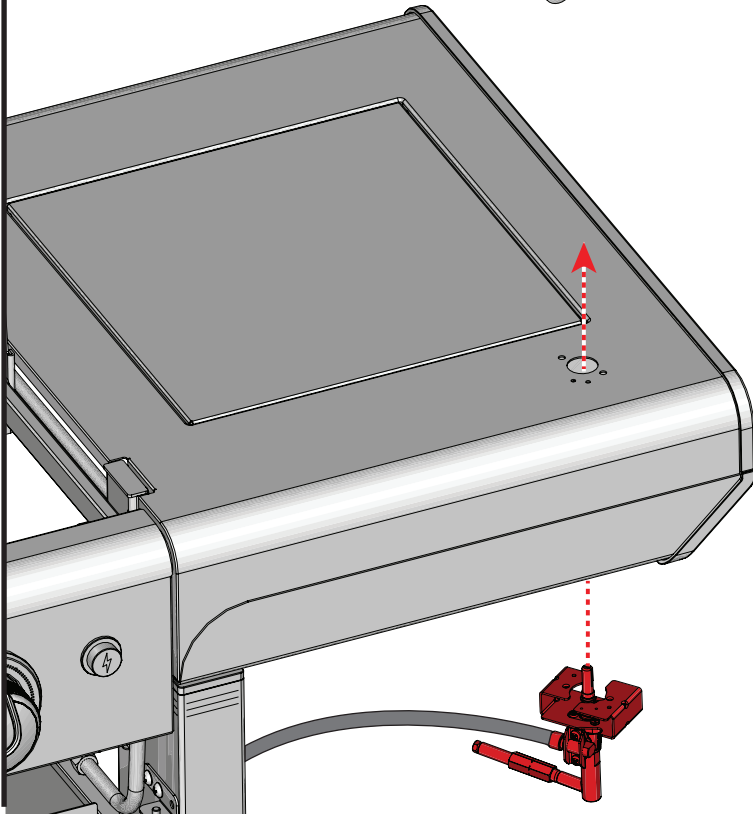

19

1x

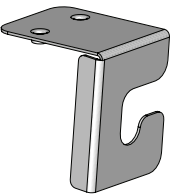

2x

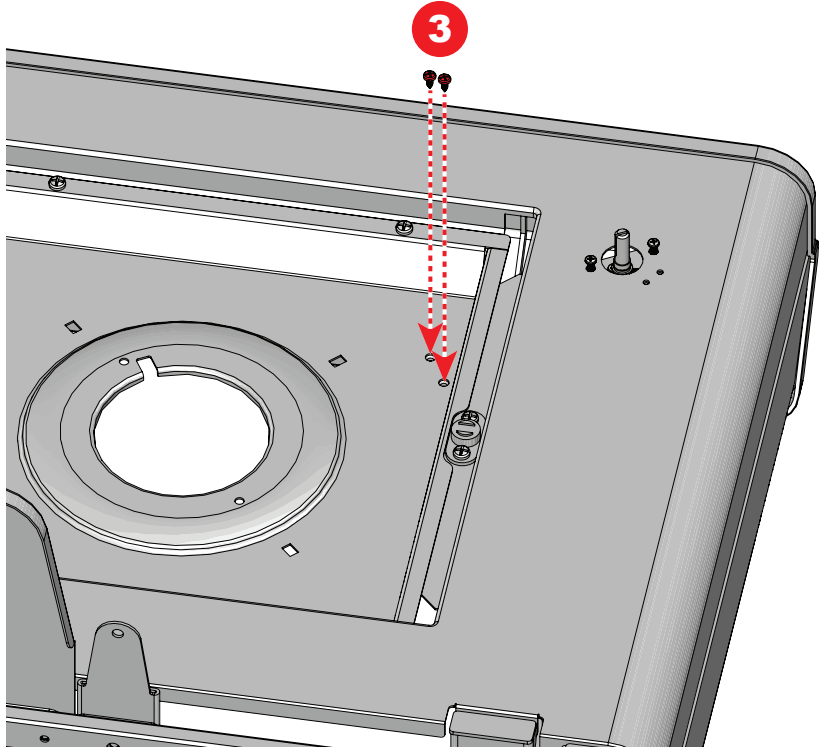
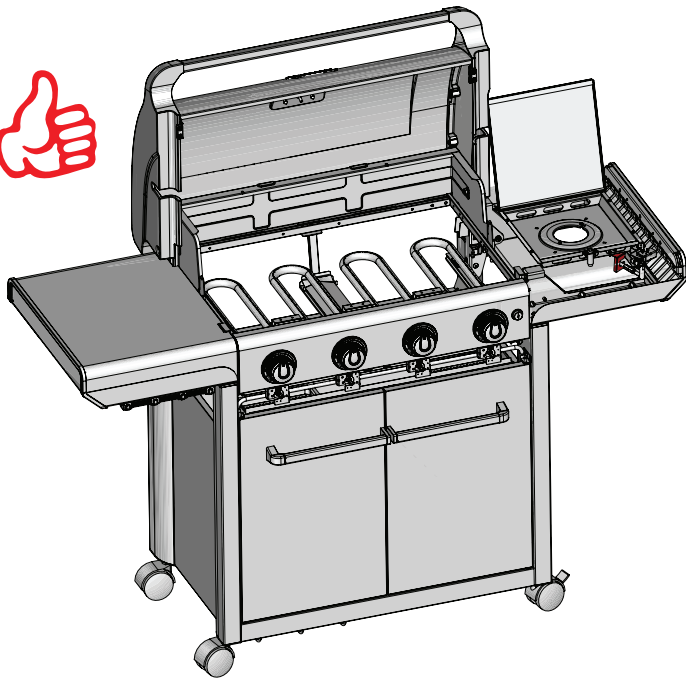
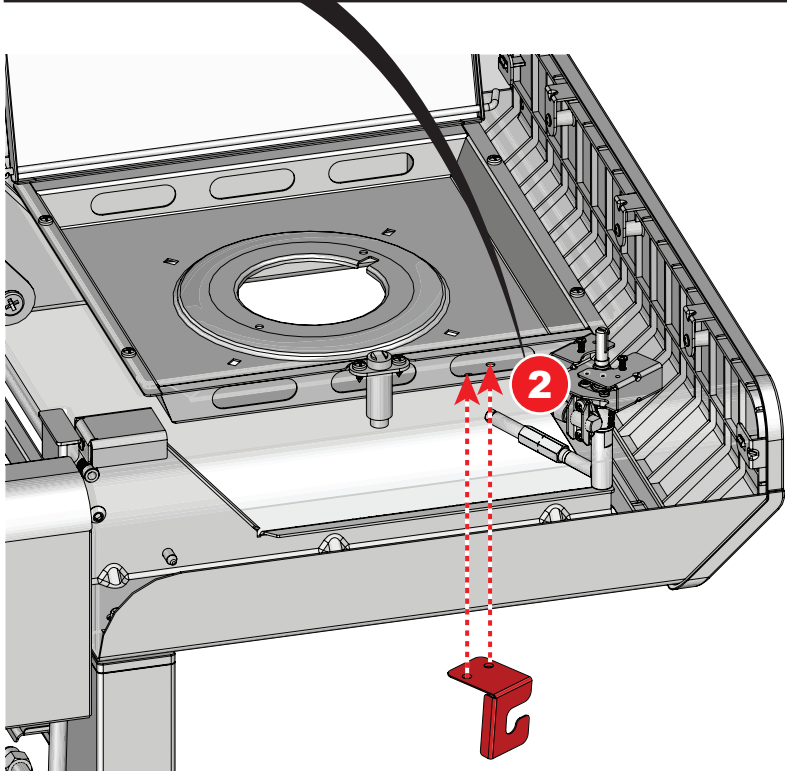
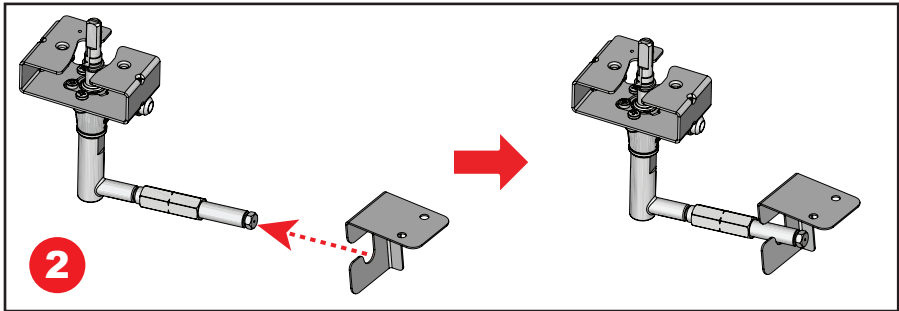
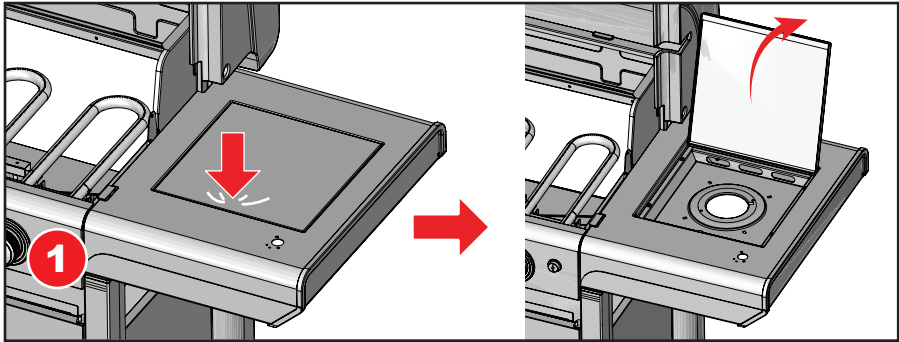
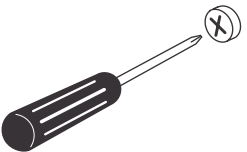
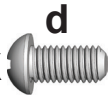

20

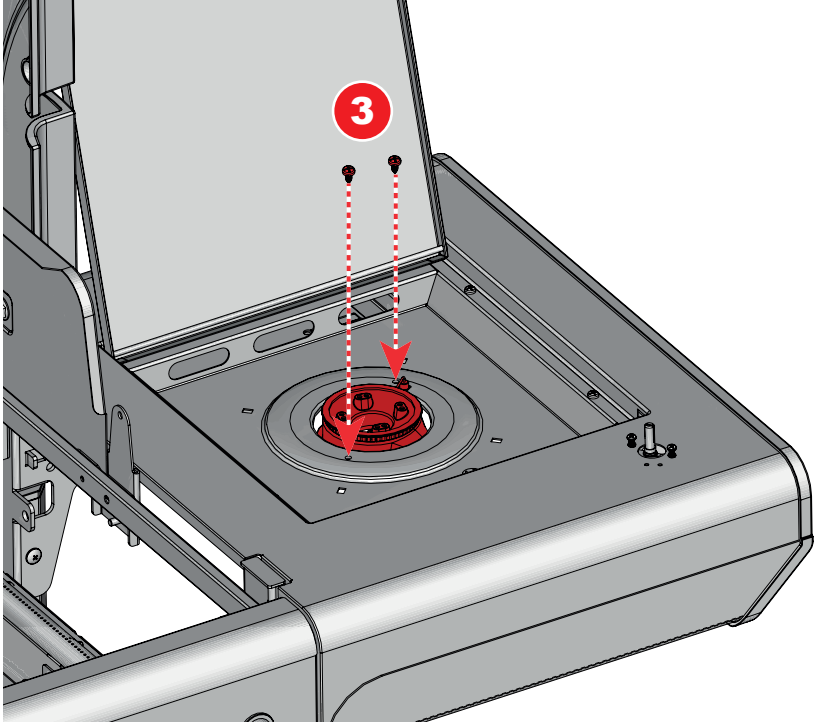
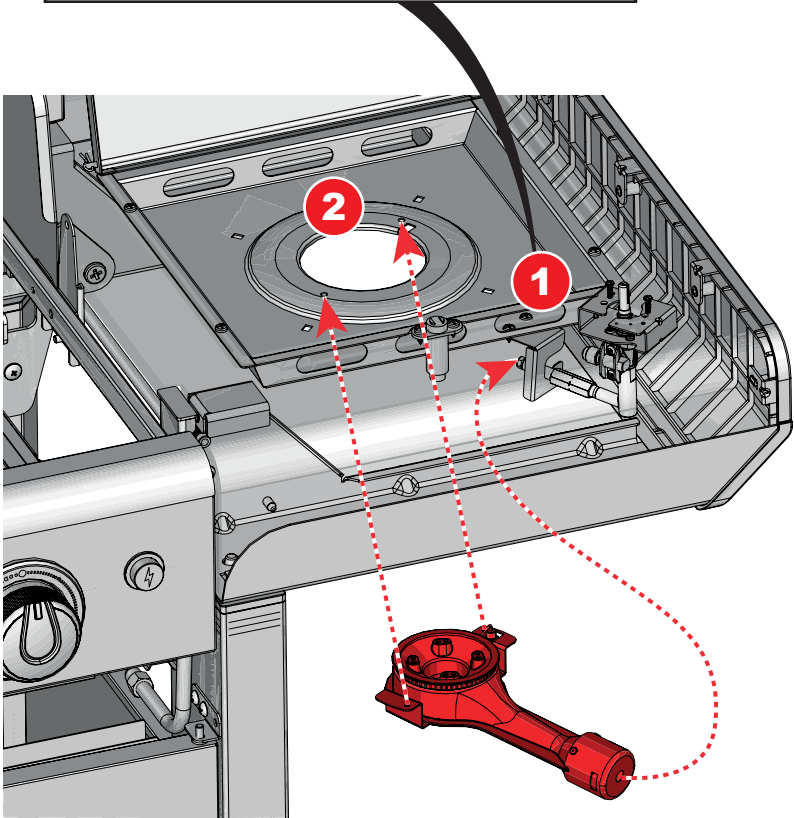
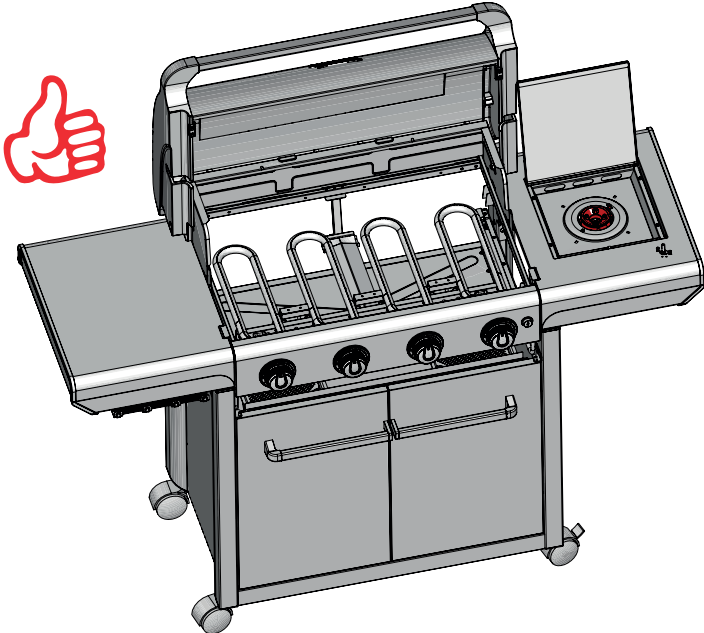
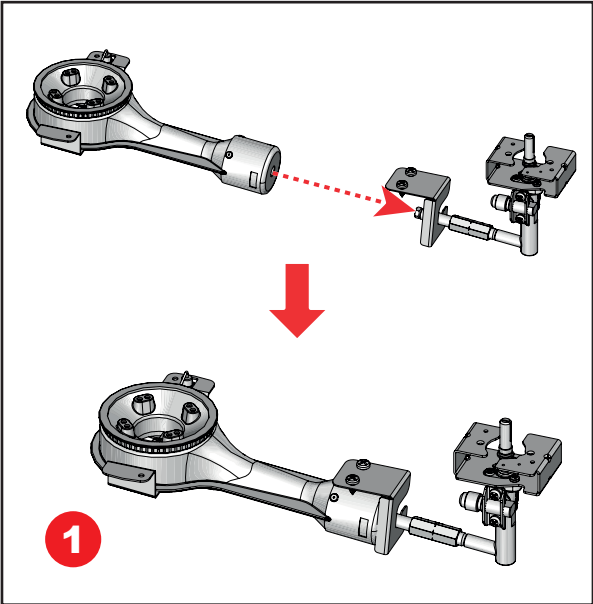
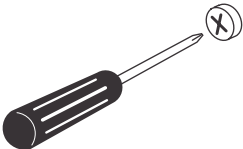
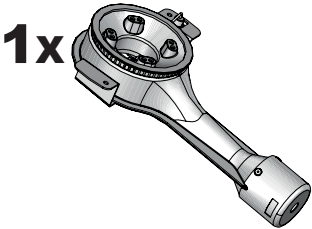

21

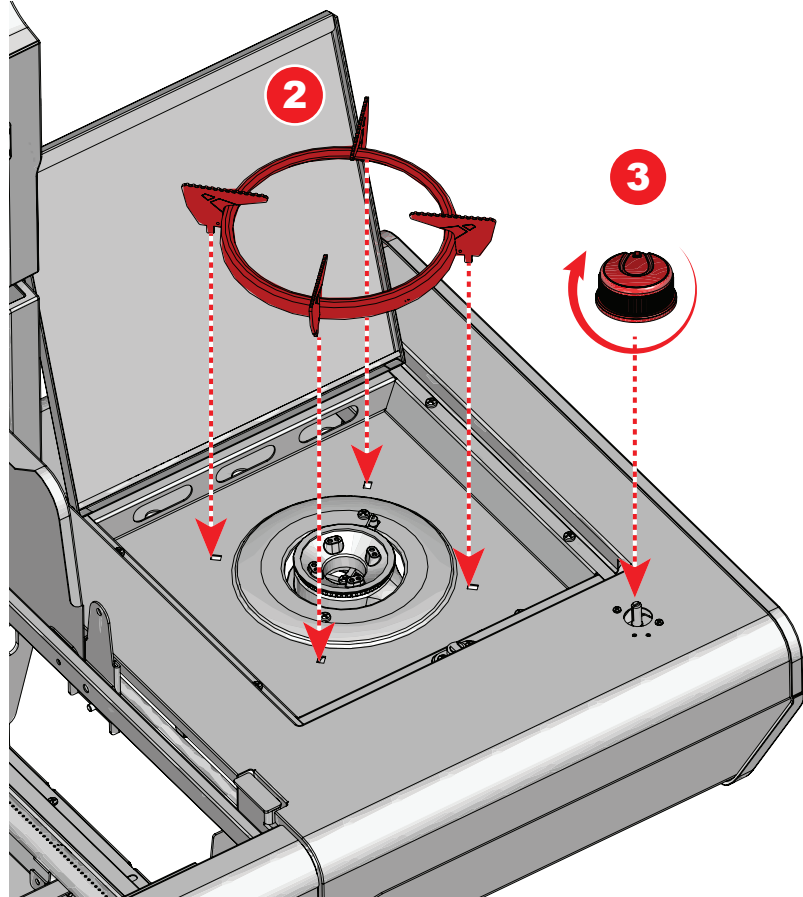
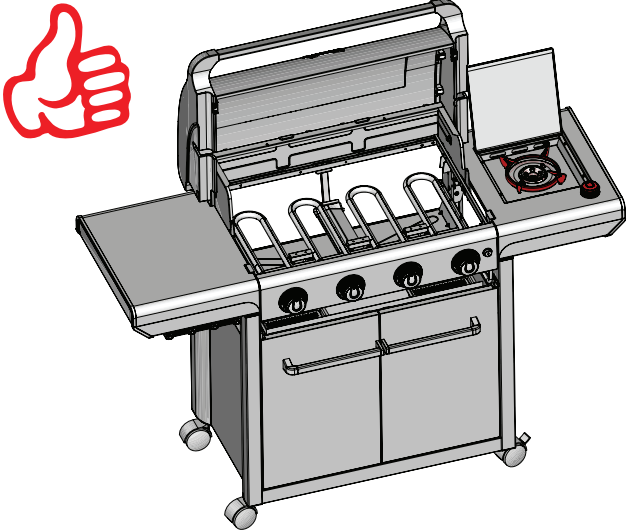
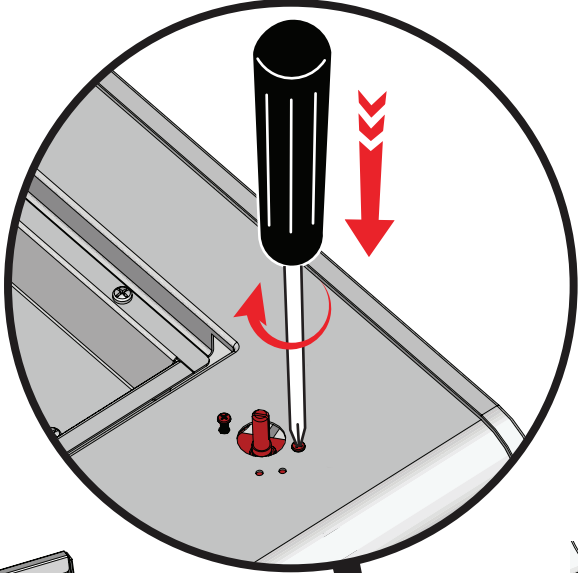
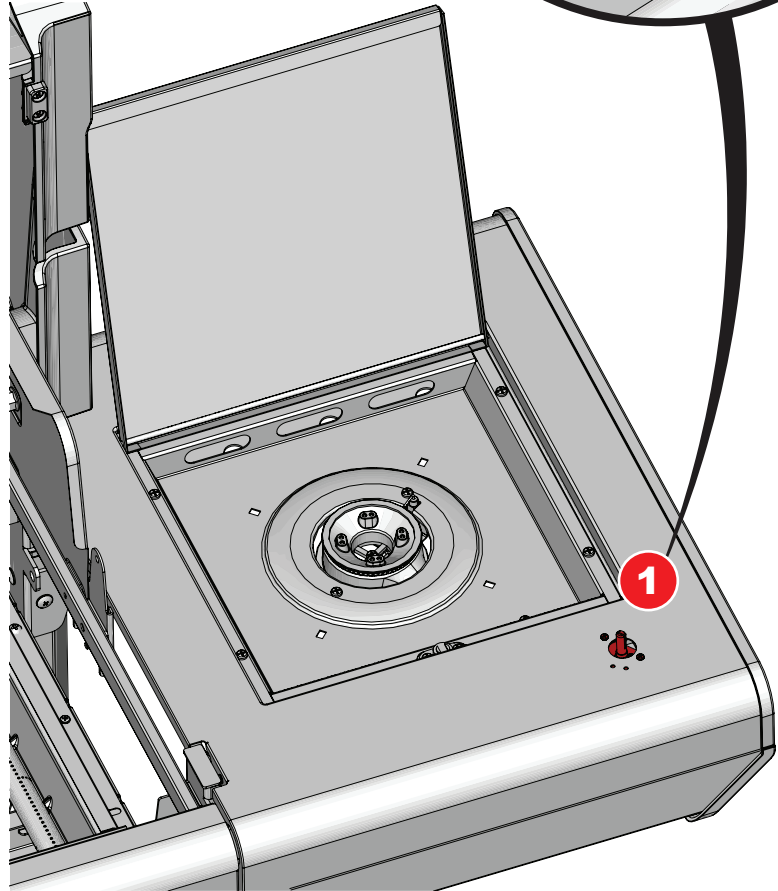
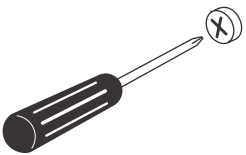
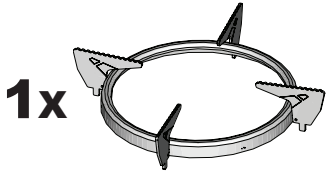

22

1x

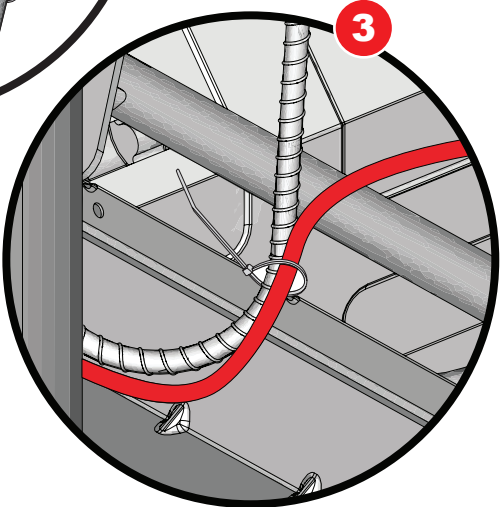
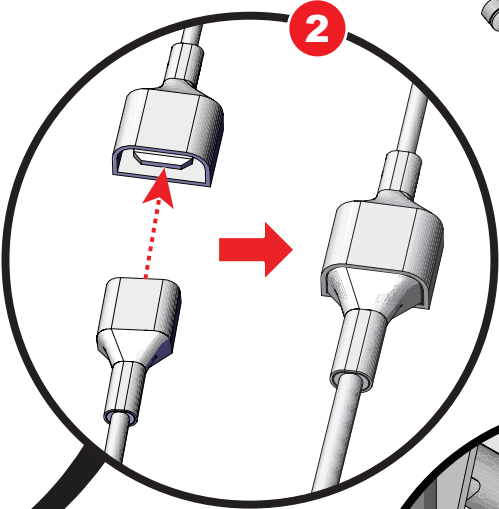
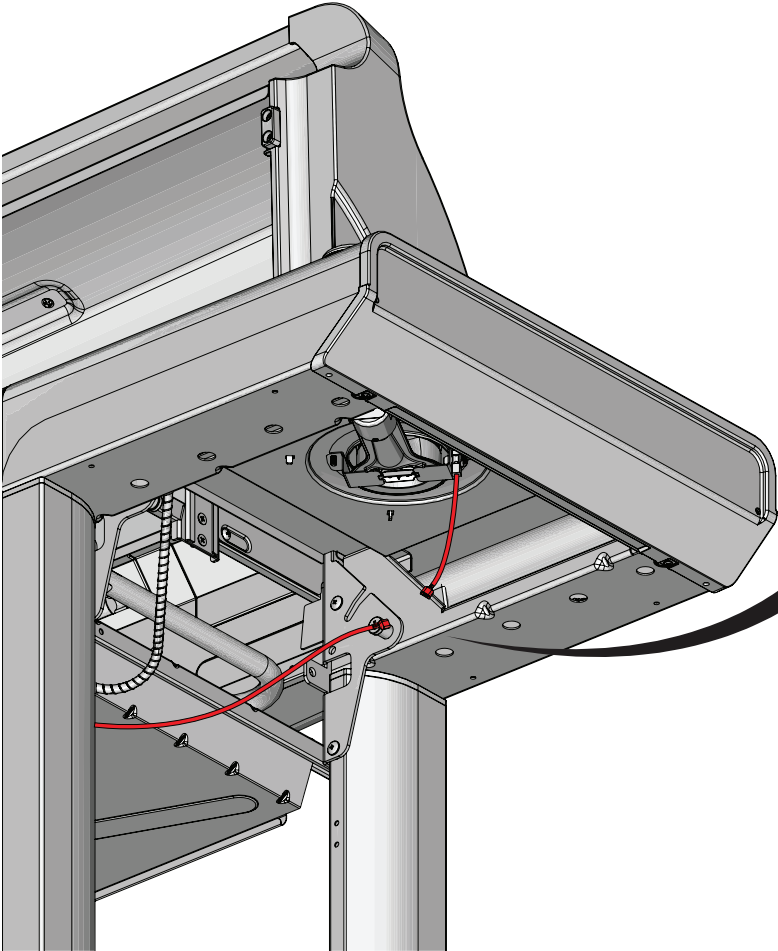
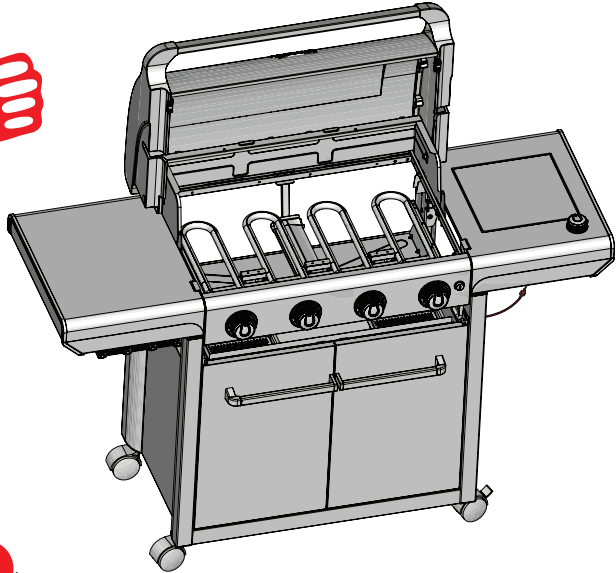
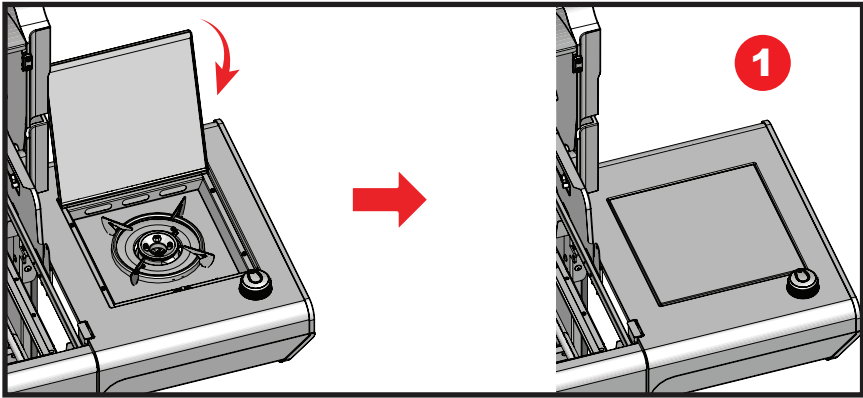

23

1x

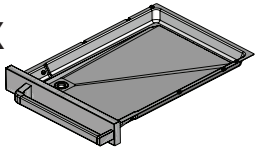

1x

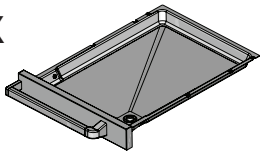

2x

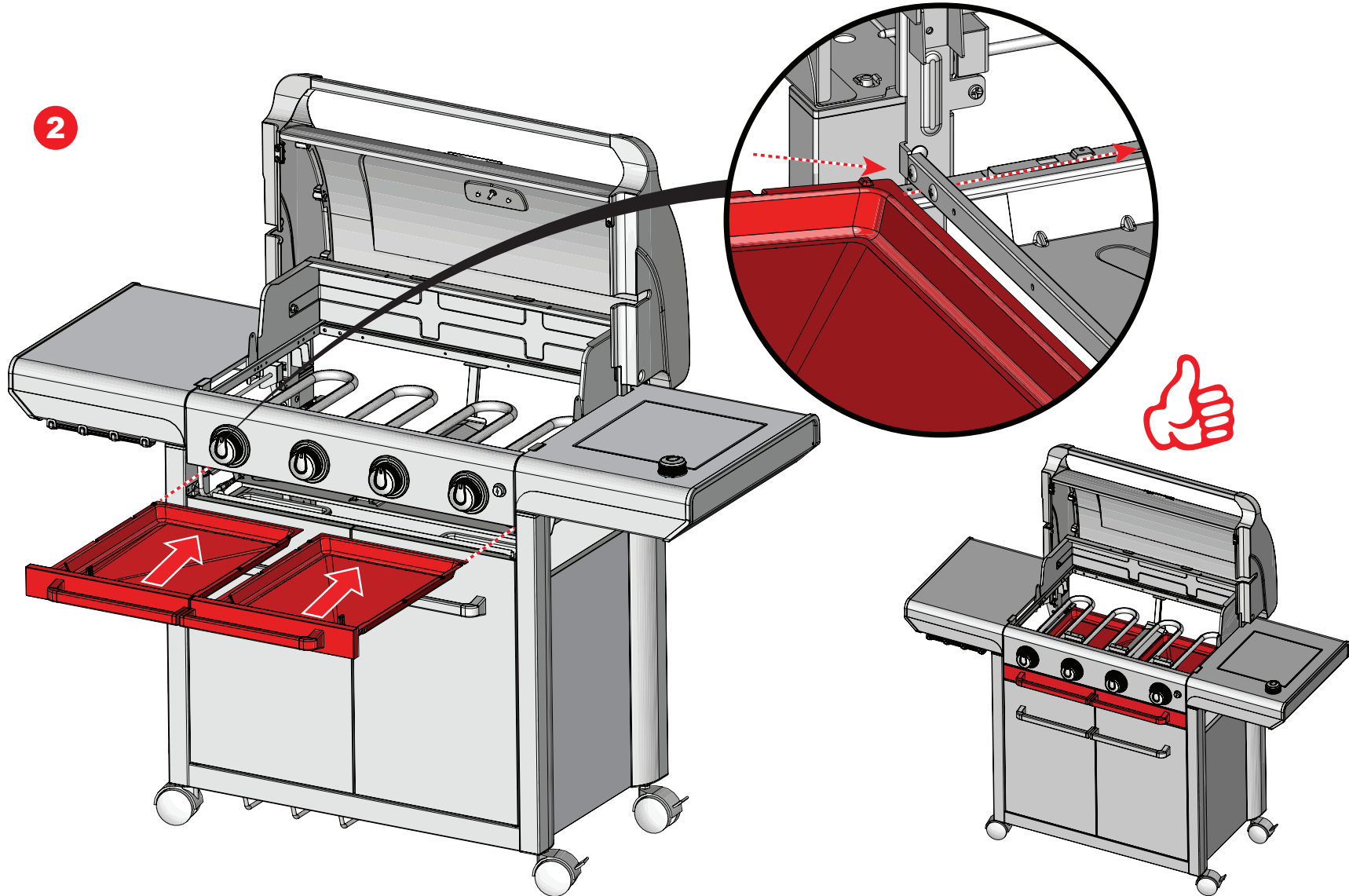
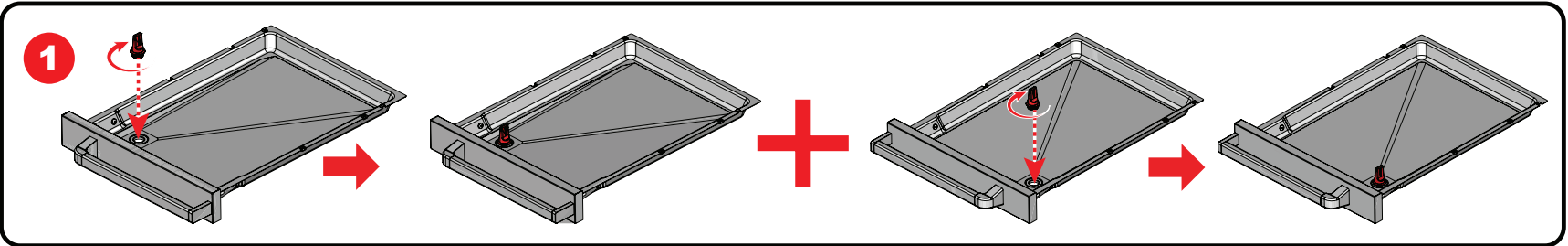

24

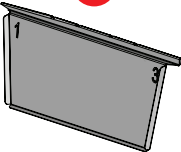
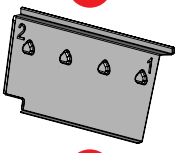
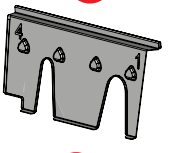
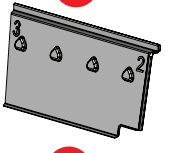
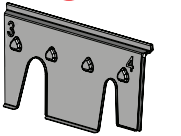
- 2x **A** 
- 1x **B** 
- 1x **C** 
- 1x **D** 
- 1x **E** 

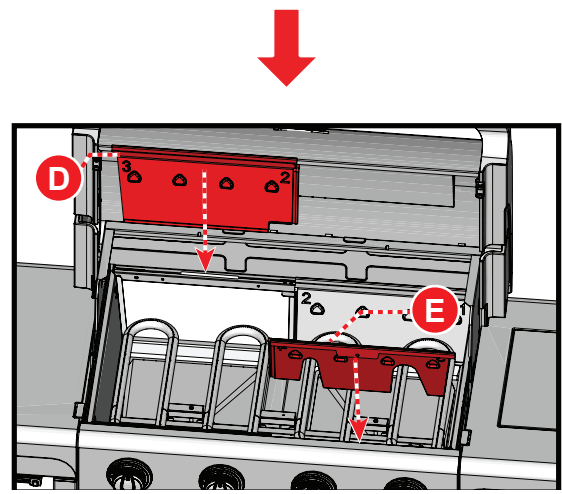
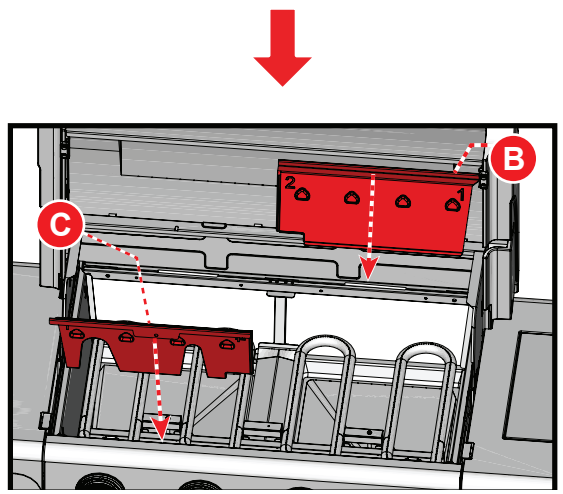
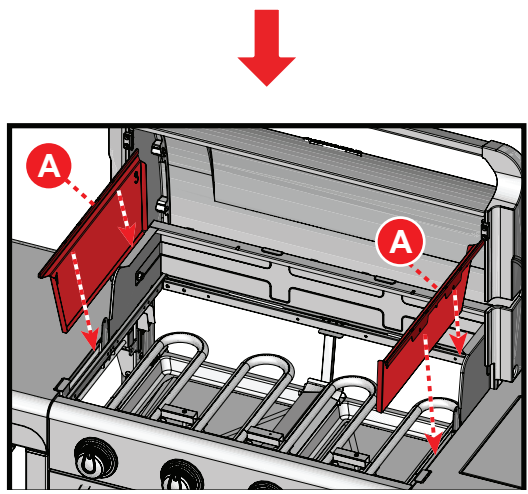
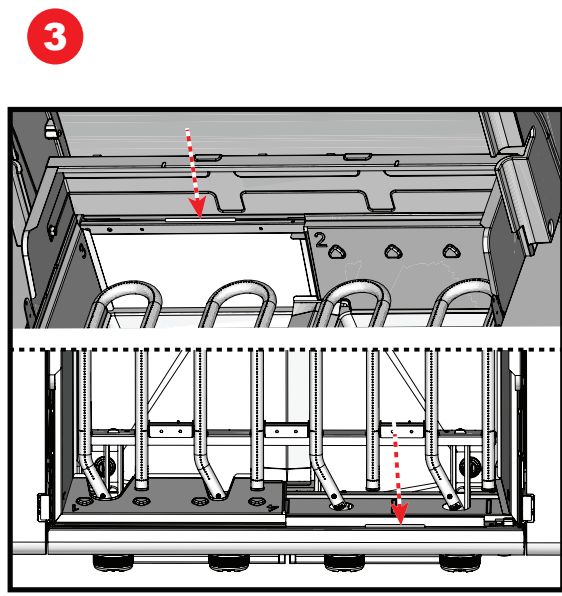
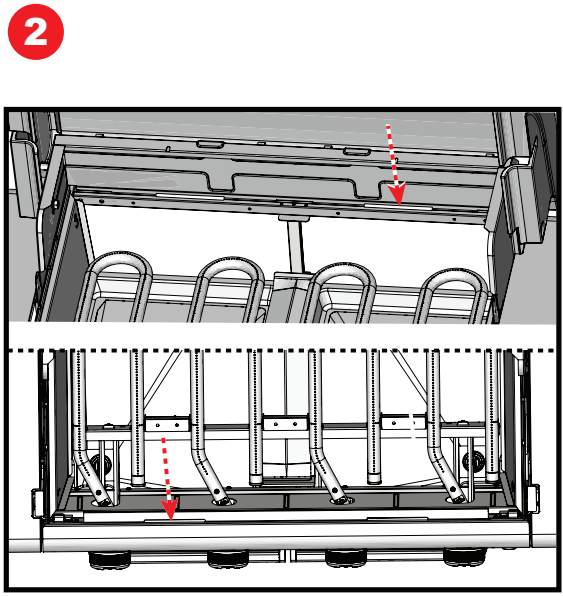
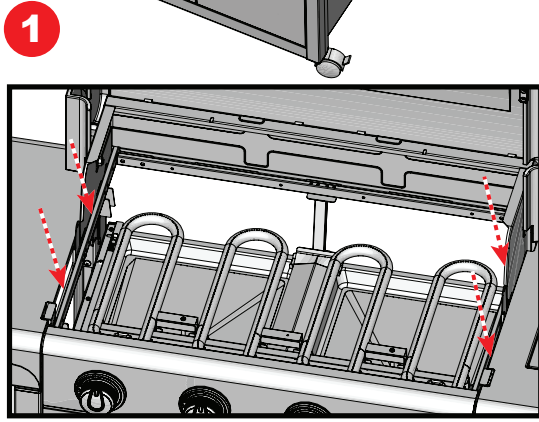
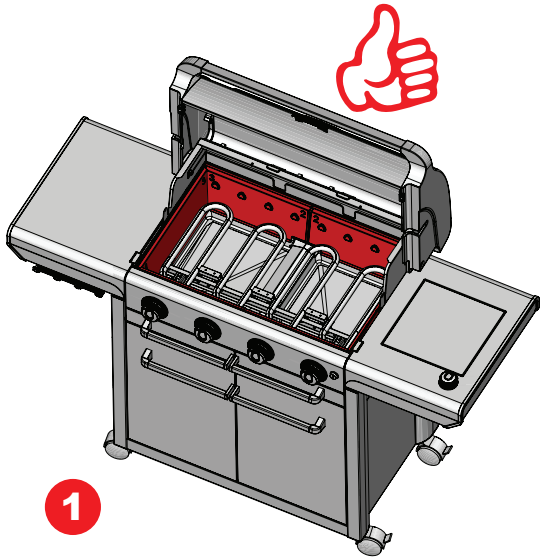

25

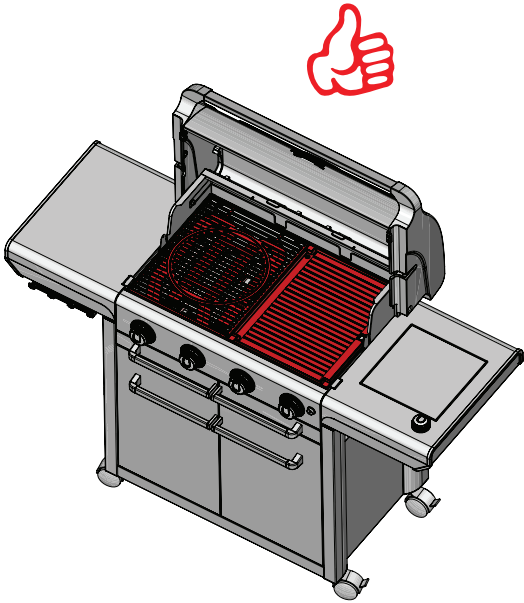
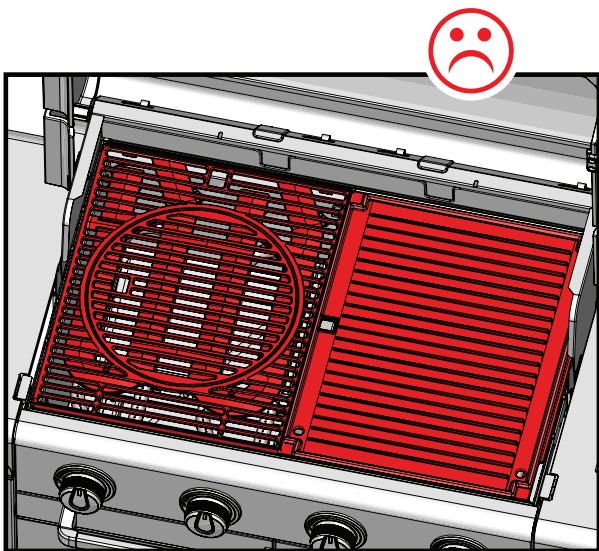
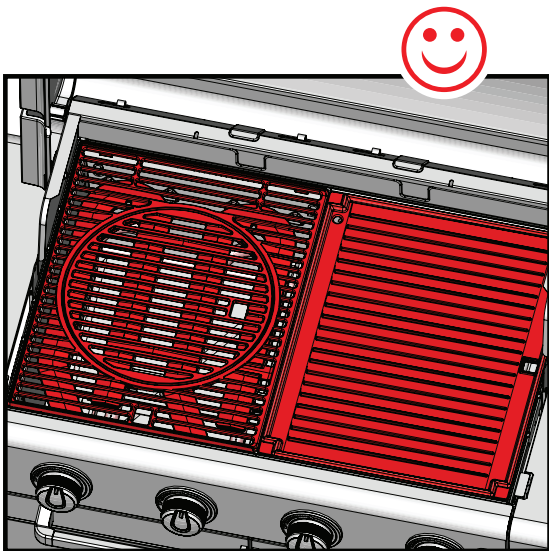
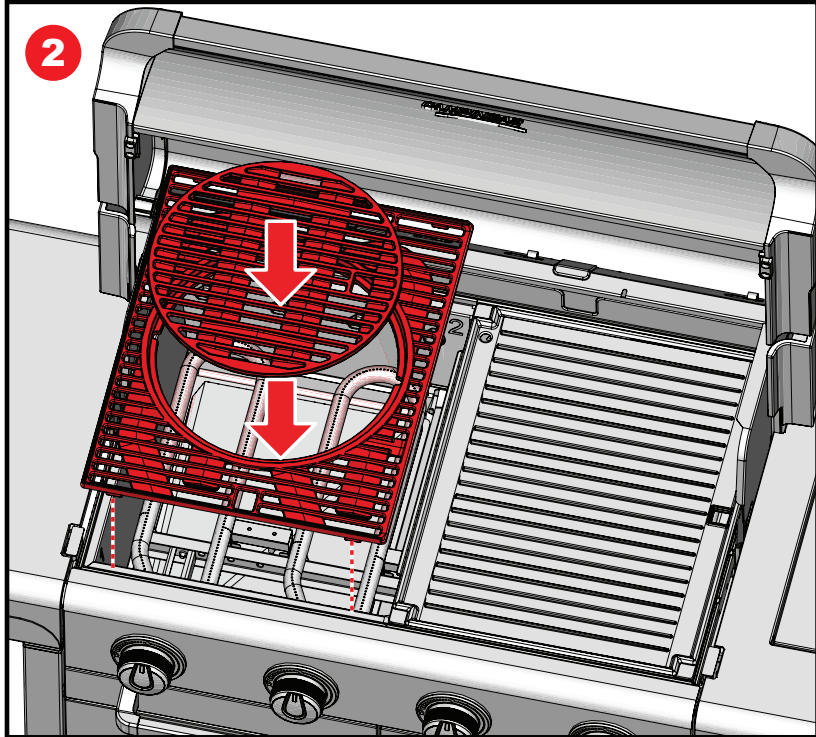
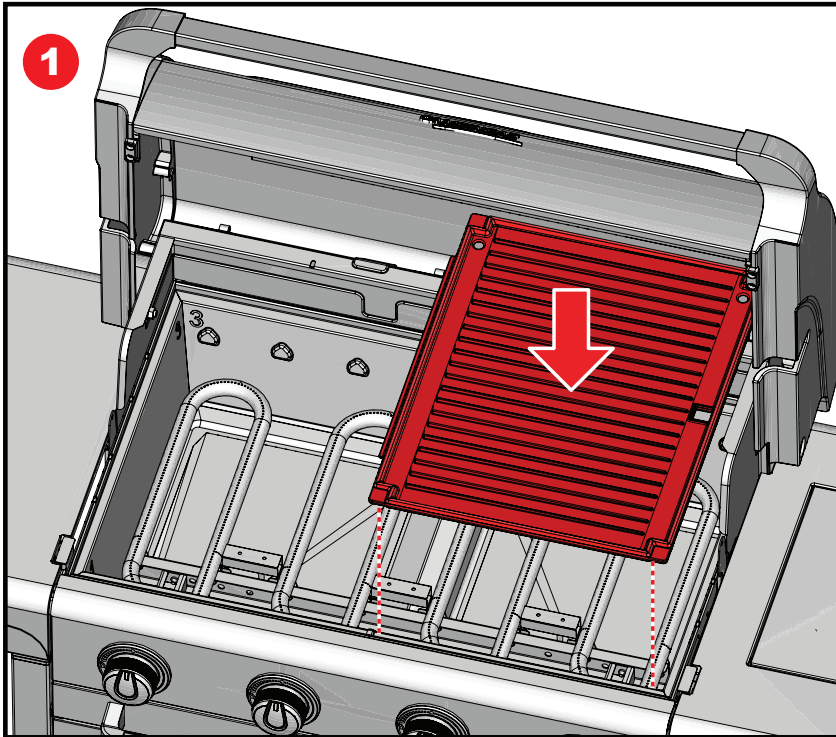
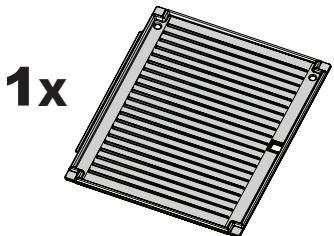
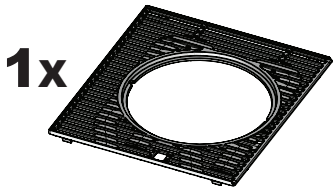

26

2x

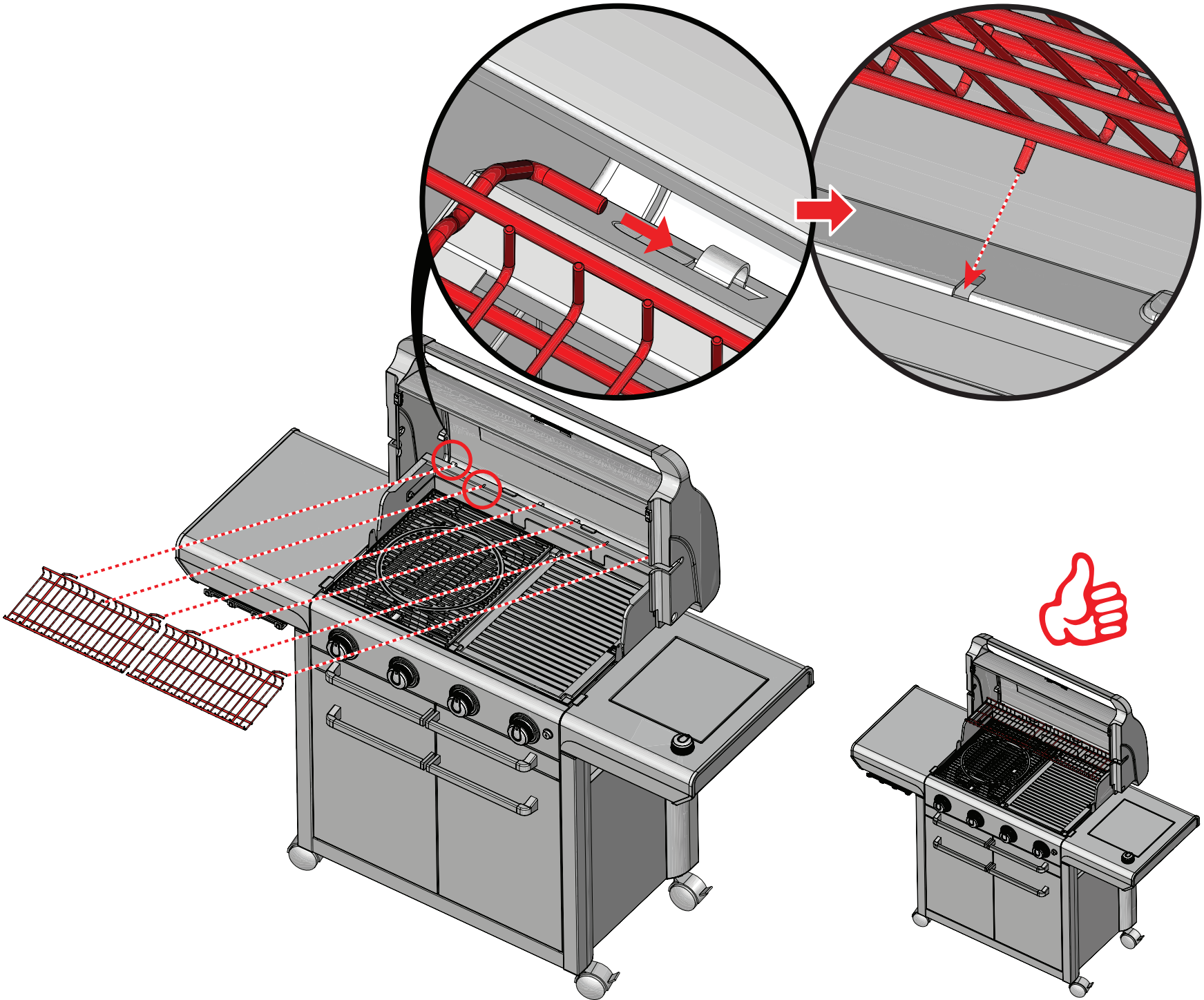
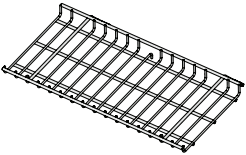

27

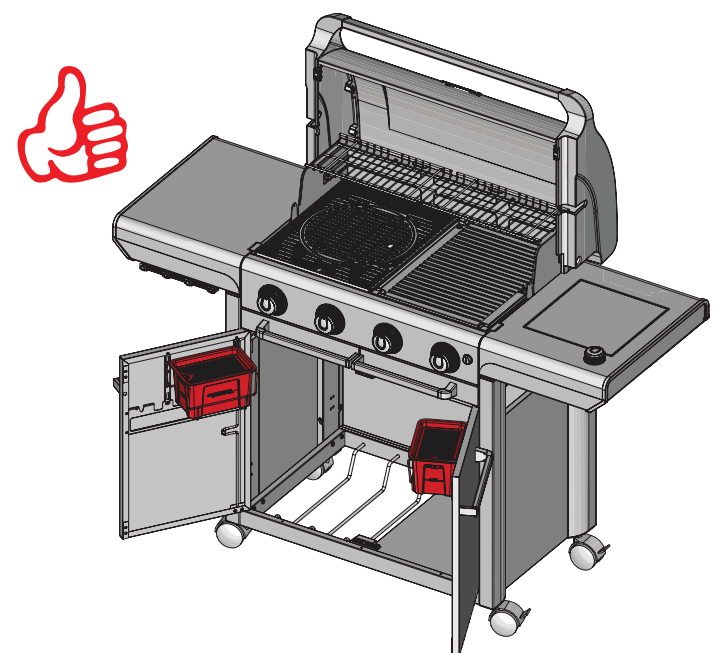
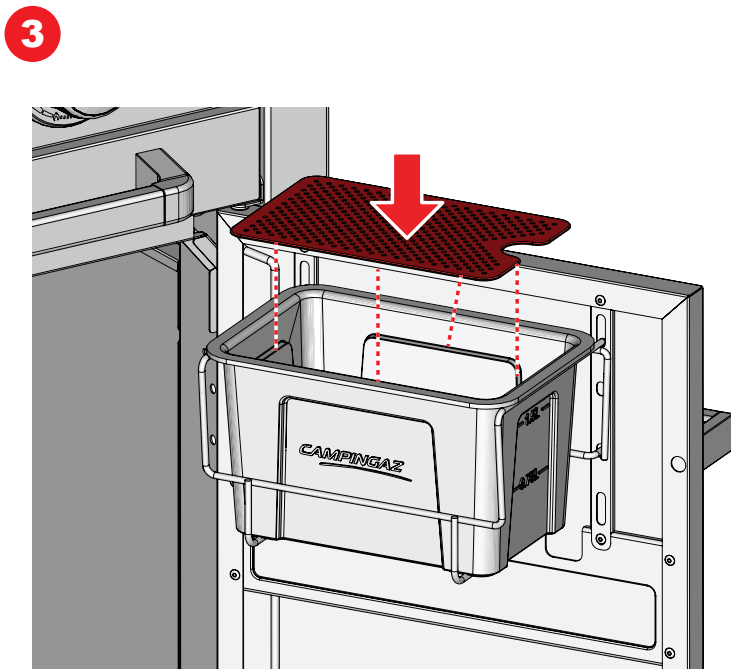
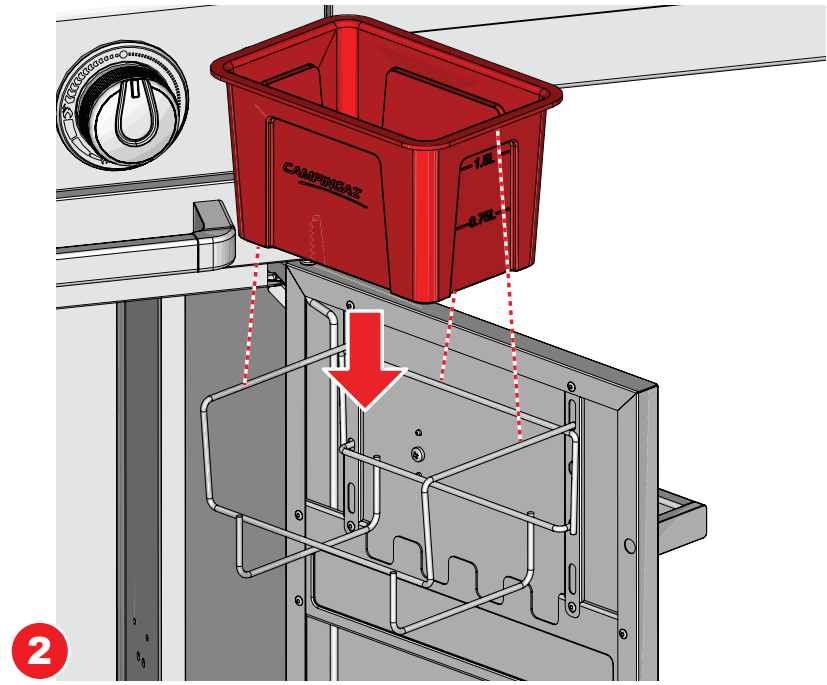
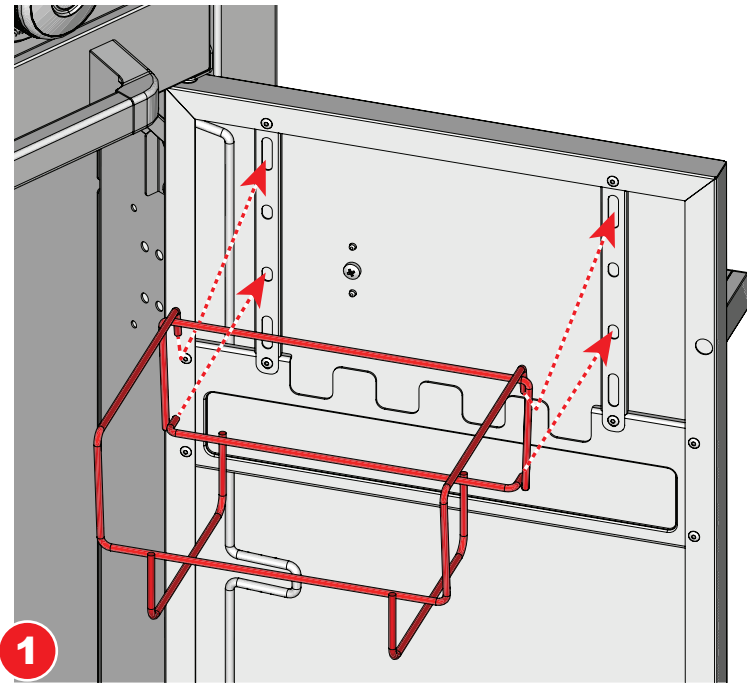
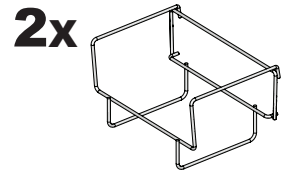
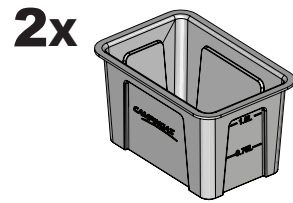
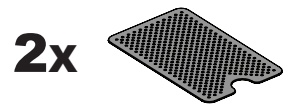

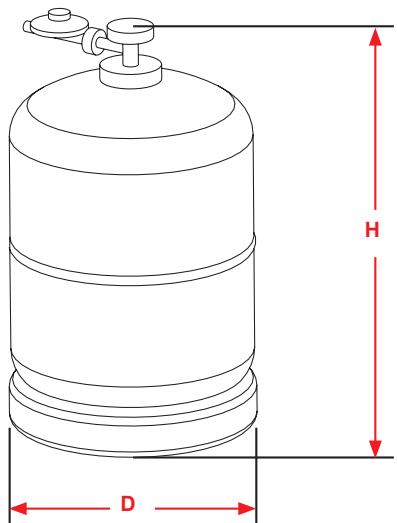

60 cm < H < 70 cm

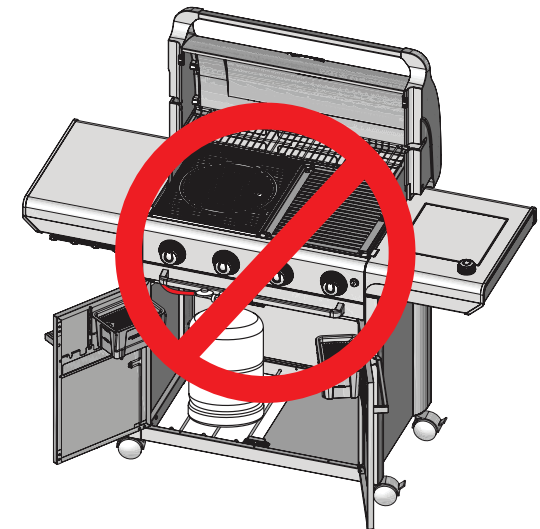
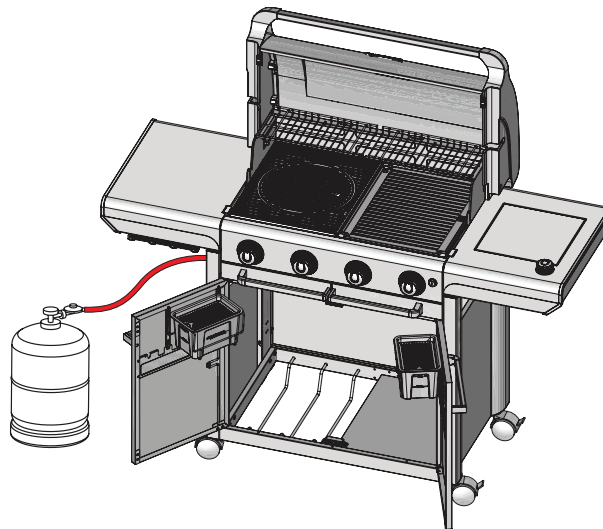

H < 60 cm D < 33 cm

