

~ Venezia ~

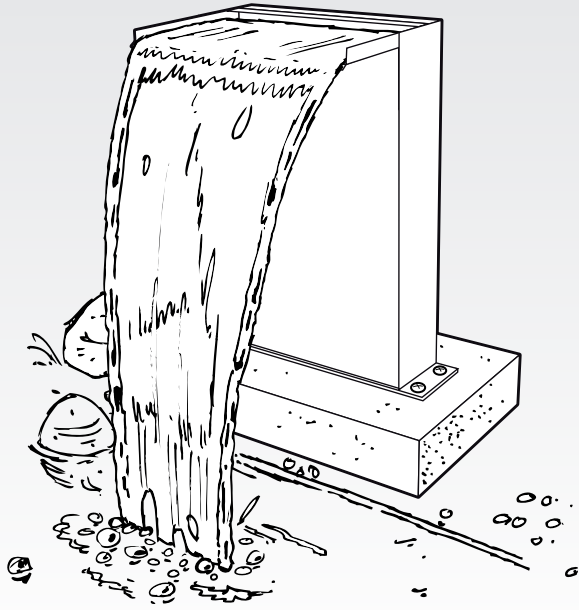

OPTION 1

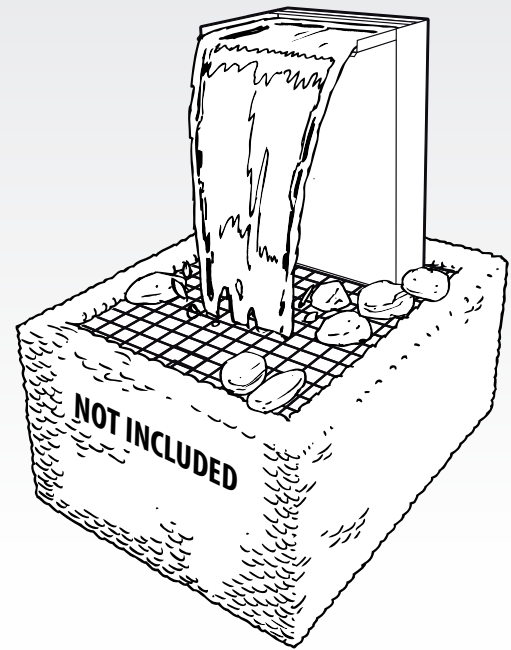

OPTION 2

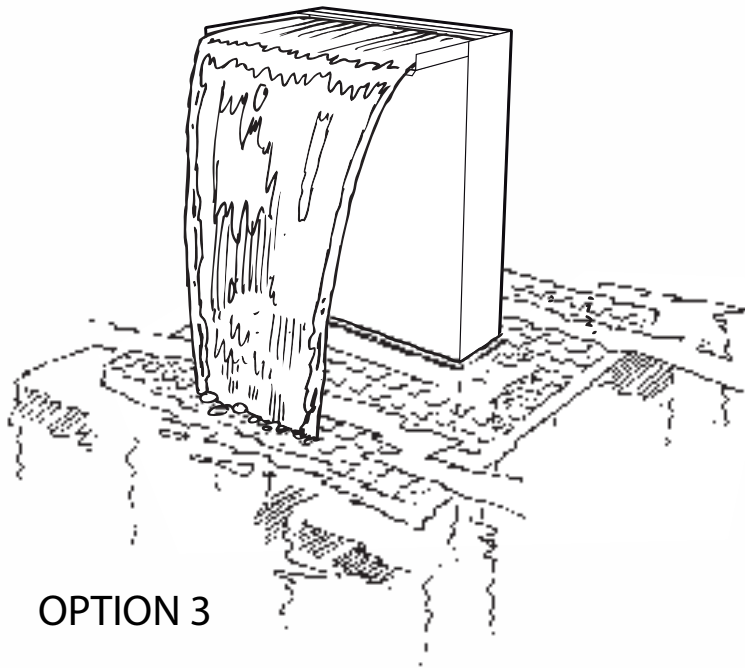

OPTION 3

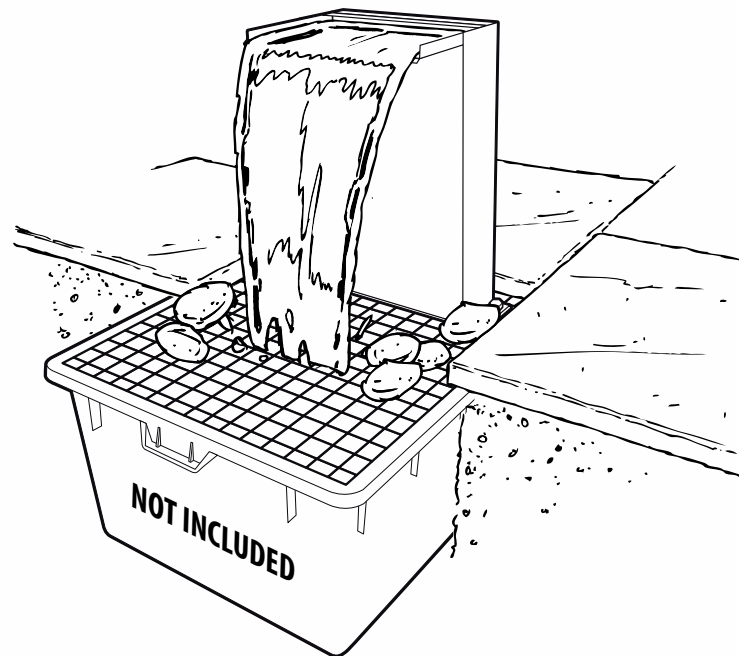

~ Venezia Option 1 ~

Contents / Inhalt / Contenu / Inhoud:

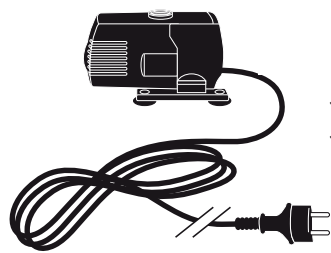

1x 1409969 EU
1x 1409967 UK

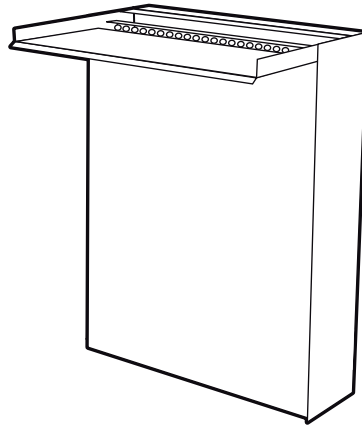

2m x 1353004



1x 1418031

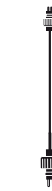
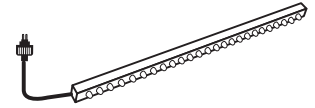

3,5m x 1418918



1x 1409848 EU
1x 1409549 UK

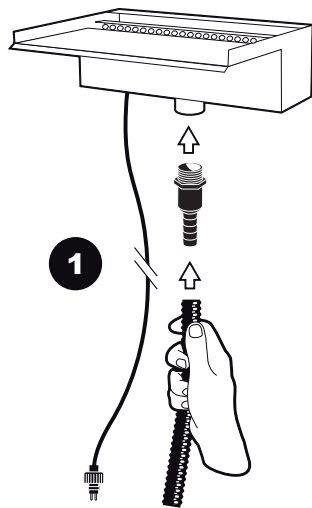

1

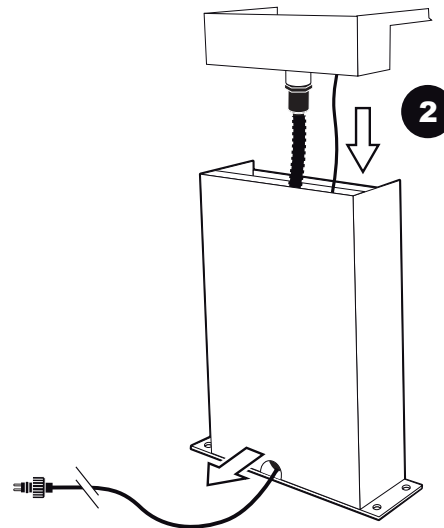

2

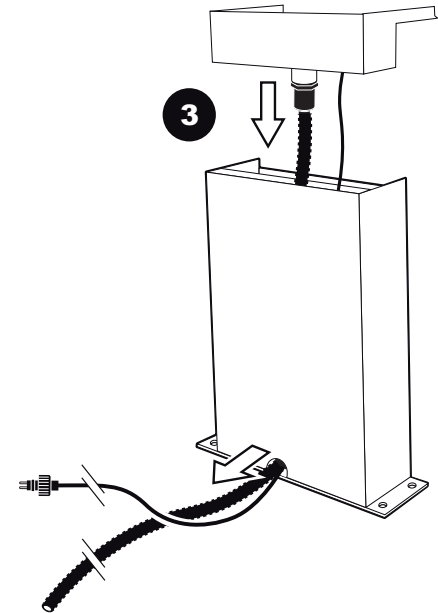

3

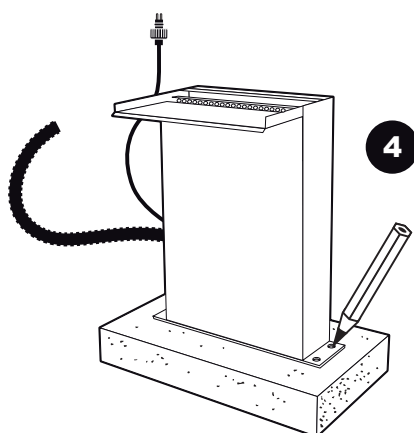

4

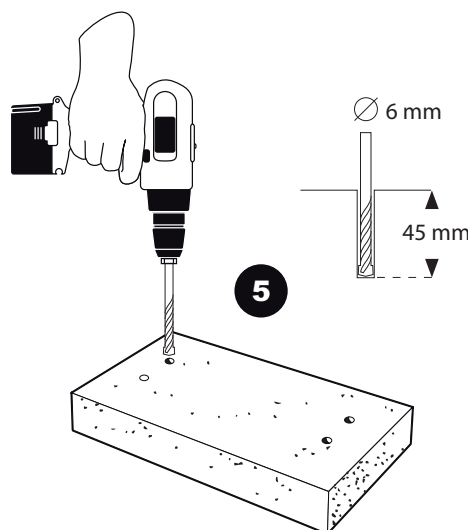

5

∅ 6 mm

45 mm



- During severe frost switch off the pump, remove ornament and pump!
- Bei strengem Frost sollte das Set ausgeschaltet sowie das Deko-Element und Pumpe entfernt werden!
- Tijdens strenge vorst set uitschakelen, ornament en pomp verwijderen!
- Protégez votre fontaine décorative et mettez votre pompe à l'arrêt pendant la période d'hiver.

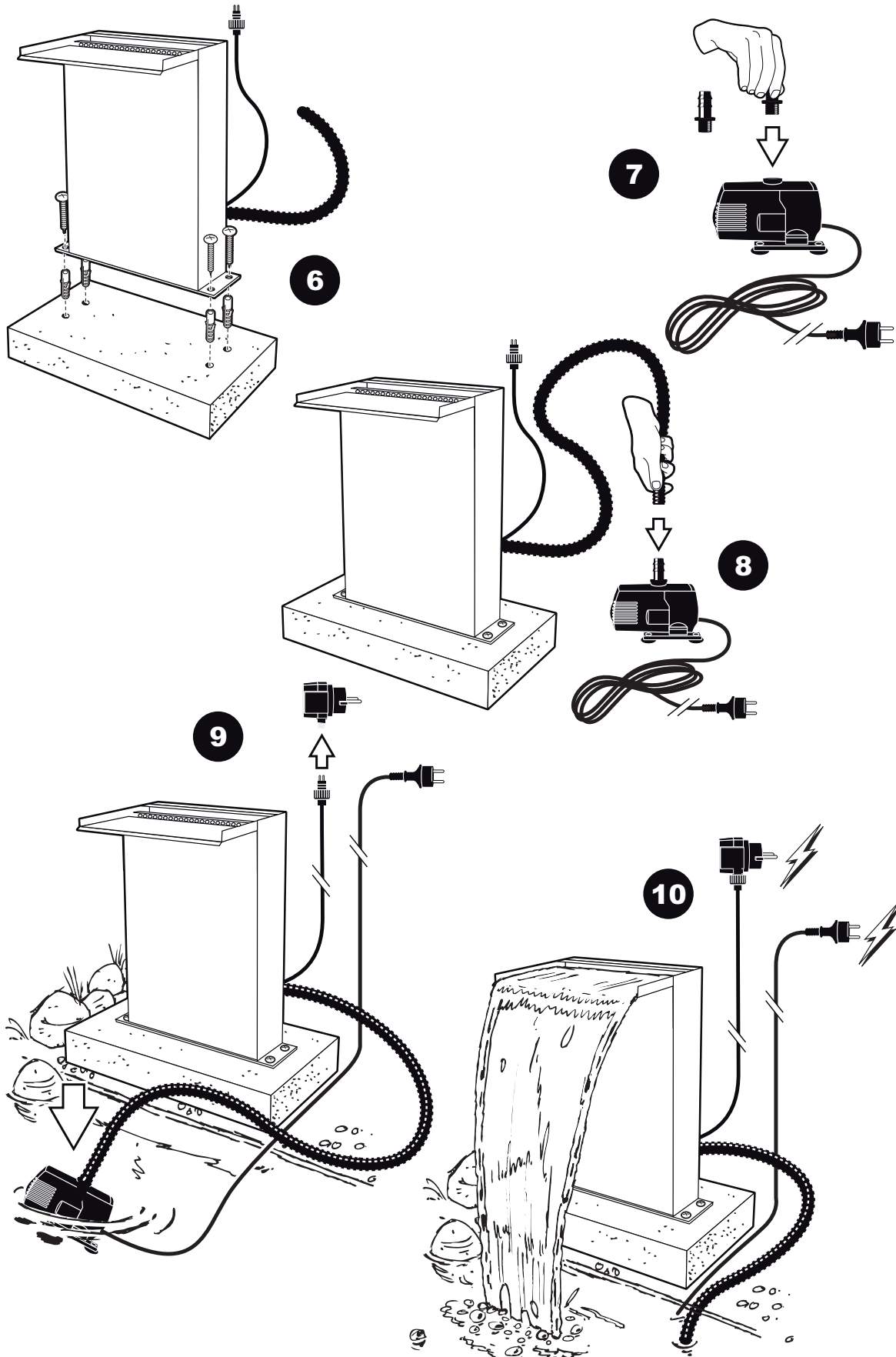



~ Venezia Option 2 ~

Contents / Inhalt / Contenu / Inhoud:

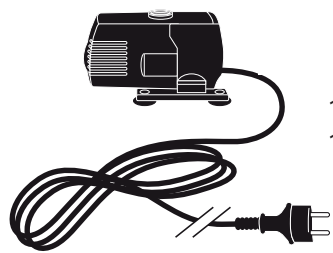

1x 1409969 EU
1x 1409967 UK

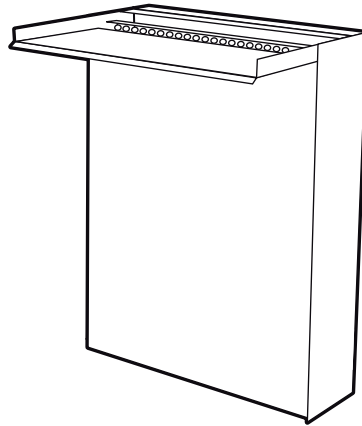

2m x 1353004



1x 1418031

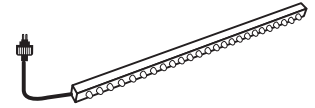

3,5m x 1418918



1x 1409848 EU
1x 1409549 UK

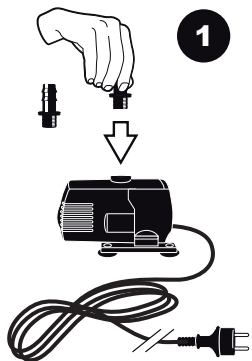

1

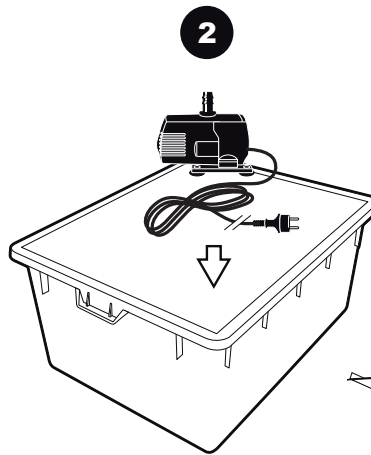

2

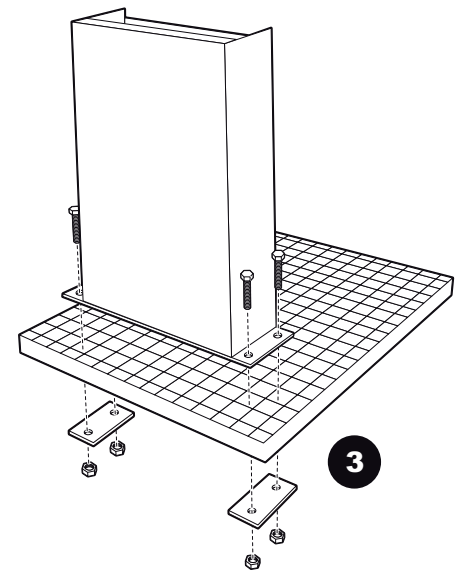

3

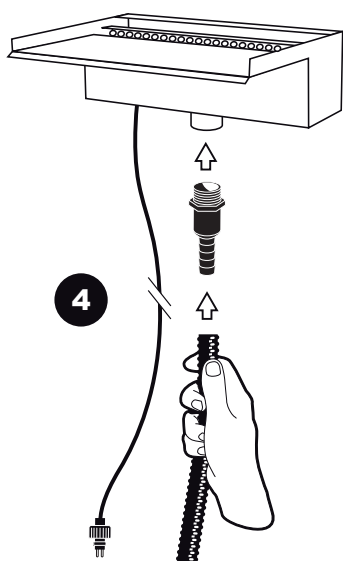

4

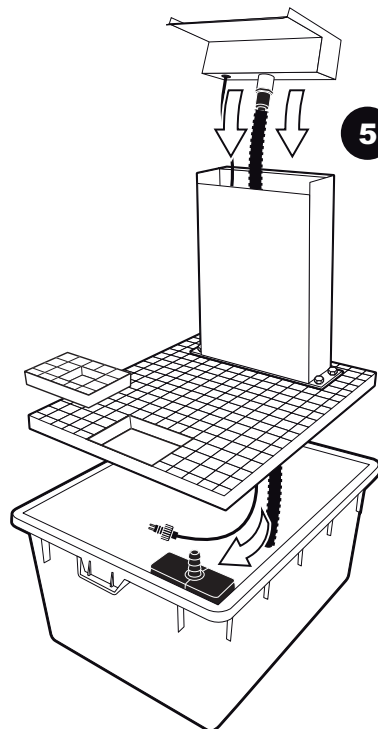

5

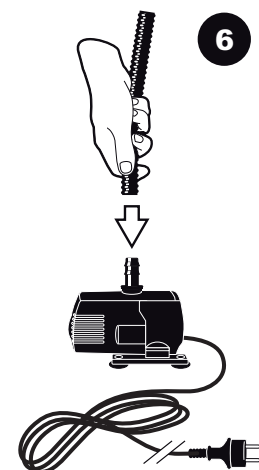

6



- During severe frost switch off the pump, remove ornament and pump!
- Bei strengem Frost sollte das Set ausgeschaltet sowie das Deko-Element und Pumpe entfernt werden!
- Tijdens strenge vorst set uitschakelen, ornament en pomp verwijderen!
- Protégez votre fontaine décorative et mettez votre pompe à l'arrêt pendant la période d'hiver.



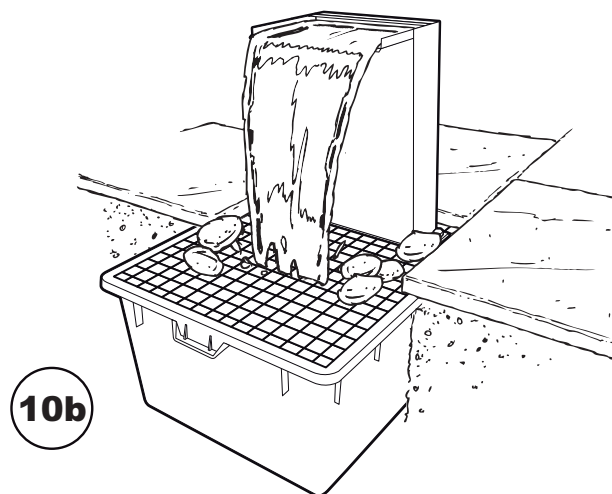
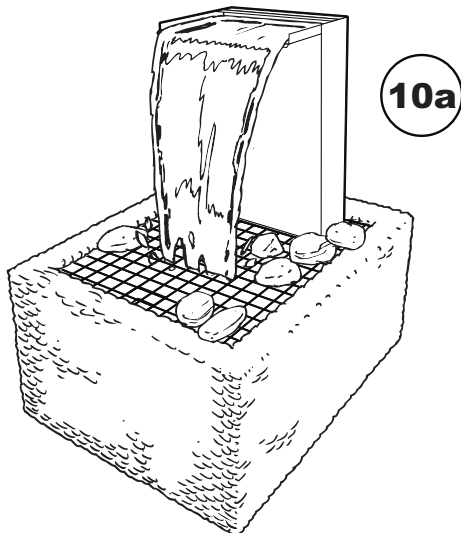
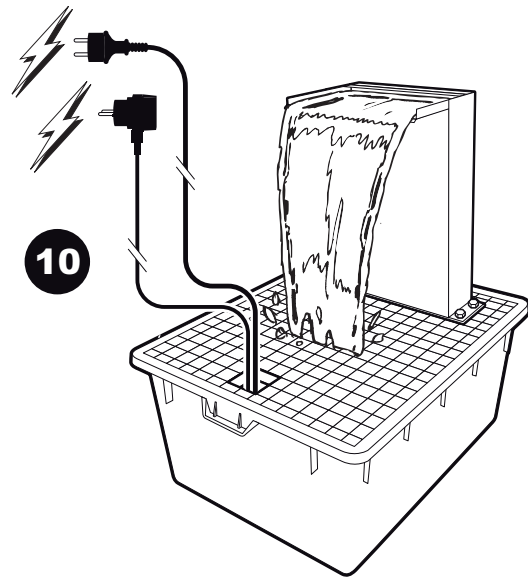
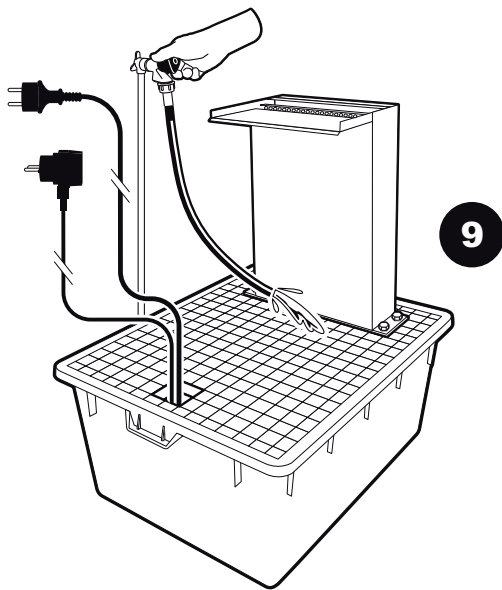
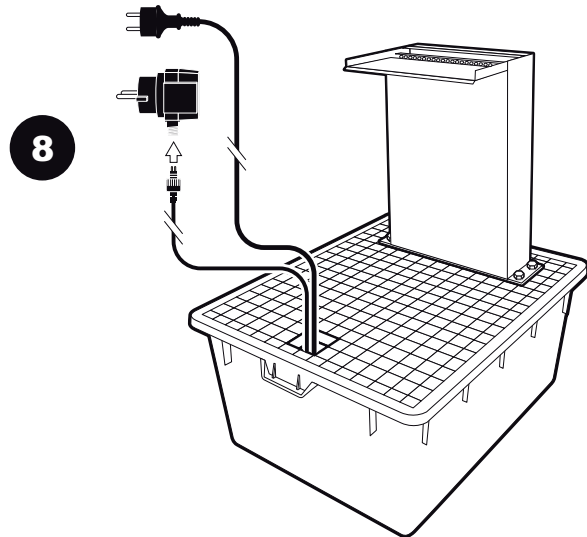
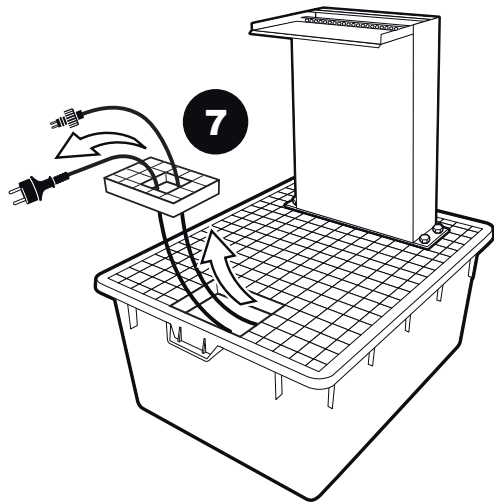

~ Venezia Option 3 ~

Contents / Inhalt / Contenu / Inhoud:

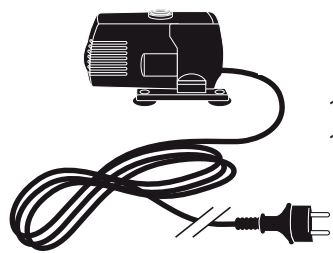

1x 1409969 EU
1x 1409967 UK

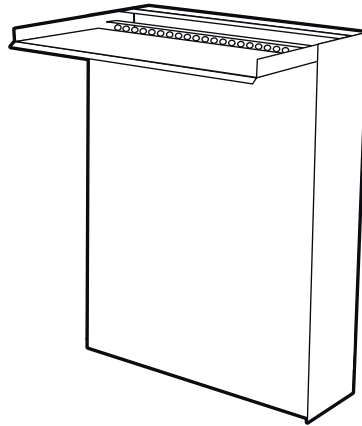

2m x 1353004



1x 1418031

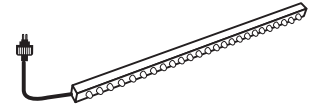

3,5m x 1418918



1x 1409848 EU
1x 1409549 UK

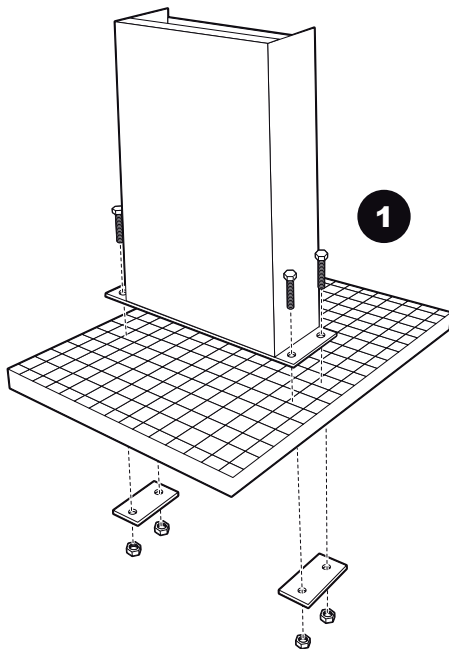

1

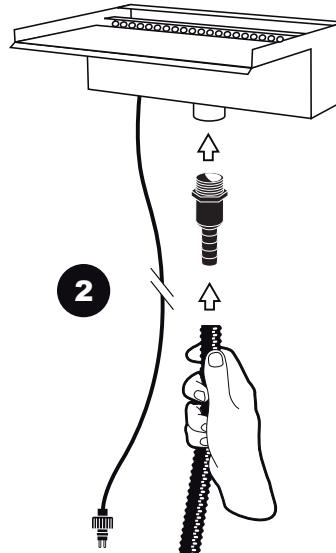

2

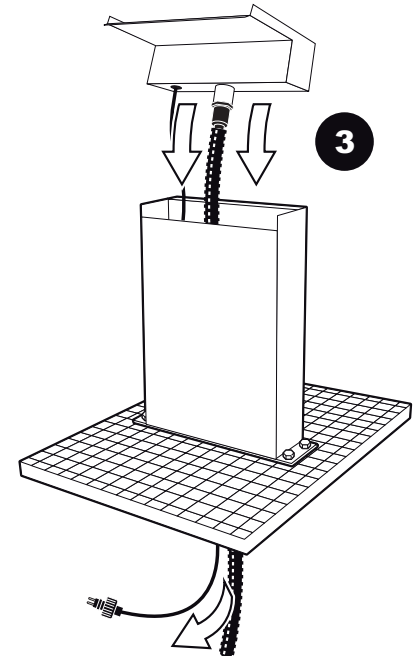

3

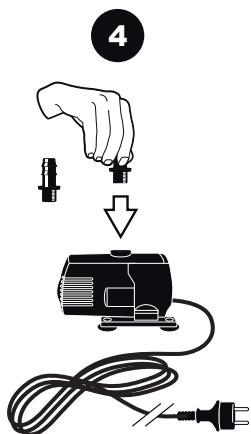

4

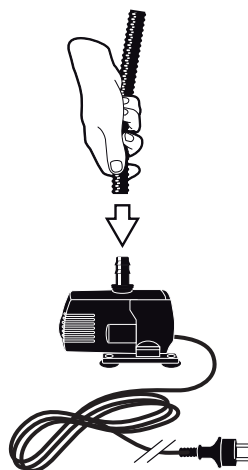

5



- During severe frost switch off the pump, remove ornament and pump!
- Bei strengem Frost sollte das Set ausgeschaltet sowie das Deko-Element und Pumpe entfernt werden!
- Tijdens strenge vorst set uitschakelen, ornament en pomp verwijderen!
- Protégez votre fontaine décorative et mettez votre pompe à l'arrêt pendant la période d'hiver.

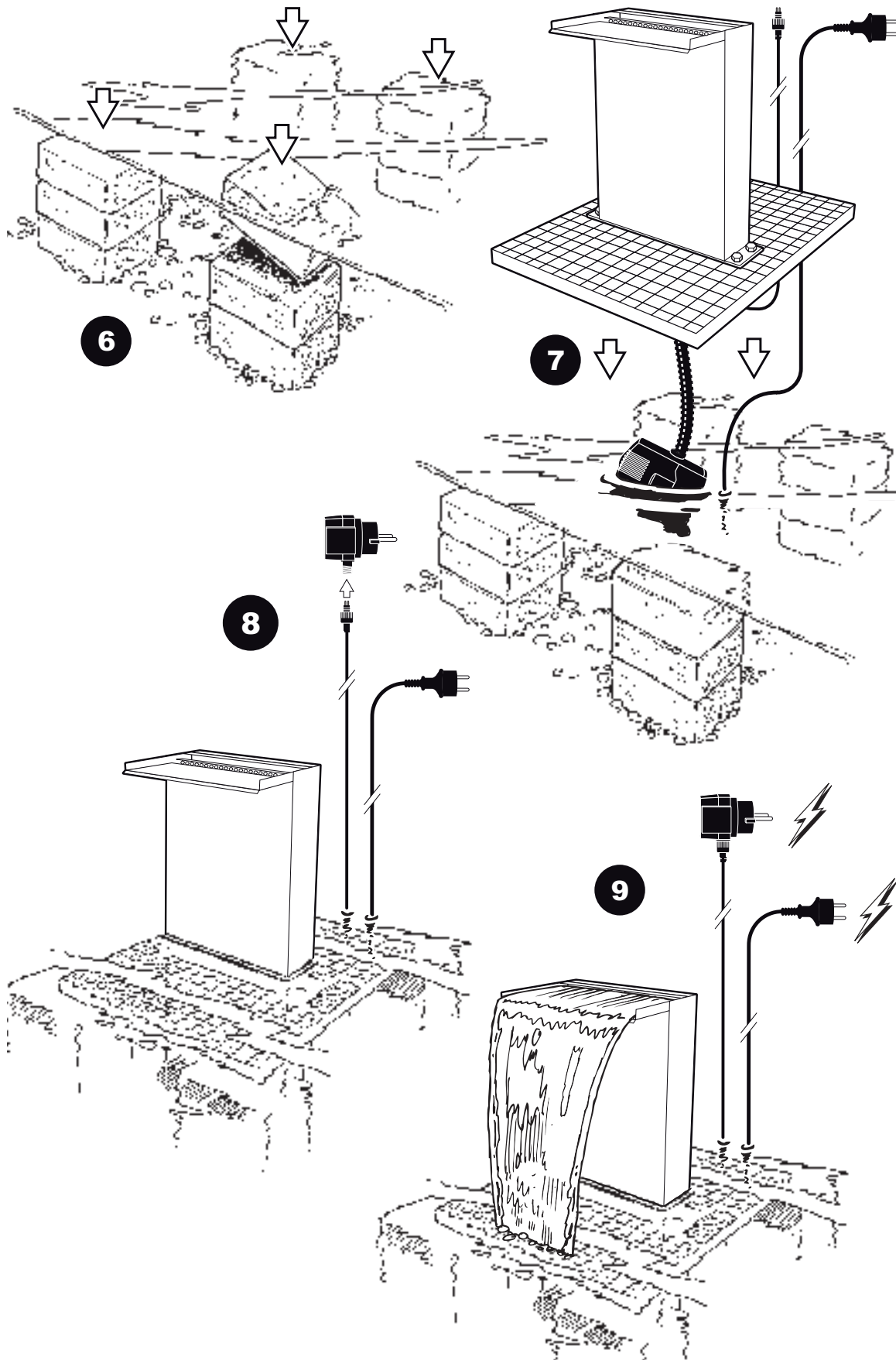





TR Paslanmaz çelik selalenin temizlenmesi

- Kurulum öncesinde önceden tespit edilememiş olası bir korozyon oluşumu olup olmadığı kontrol edilmelidir.
- En uygun zaman aralığını belirlemek için önce haftalık temizliklerle başlayın. Kalıntı oluşmamasına dikkat edin (tuz veya diğer katı maddeler).
- Şelalenin üzerinde tuz, toz ve kir kalıntılarını bulunmamalıdır.
- Özellikle demir ve beton olmak üzere diğer metallerle doğrudan irtibatı engelleyin.
- Temizlik için normal durumlarda havuzun klorlanmamış suyunu kullanabilirsiniz. İlk pas lekeleri meydana geldiğinde paslanmaz çelik temizleyicisi (aşındırıcı olmayan) veya %10-15 su çözeltili nitrik asitle temizleyin. Her iki durumda da tatlı su ile durulayın ve pamuk bez ile silin.
- Özellikle aralık alanlara (örn. LED barının sabitleme yeri) ve su seviyesindeki kalıntılara dikkat edin.
- PH değerini düzenli olarak kontrol edin ve dezenfeksiyon maddelerinin doğru kullanımına dikkat edin.
- Su ile irtibatta paslanmaz çelik parçalarda kalıntı oluşmaması için suyun sirkülasyonunu sağlayın.
- Yıllık önleyici bakımla şelale elemanını kontrol edin.

تنظيف شلالات المياه المصنوعة من الاستنلس ستيل

- قبل القيام بالتركيب يجب فحص شلال المياه، وذلك من أجل إثبات وجود أي صدأ محتمل بفعل أية معادن أو مواد كيميائية محتملة لم يتم إثبات وجودها في بادئ الأمر.
- ابدأ بعملية تنظيف أسبوعية لاكتشاف وتحديد المسافة الزمنية المثالية للتنظيف. واحرص على عدم تكون أية رواسب (على سبيل المثال: الأملاح أو المواد الصلبة الأخرى).
- لا يسمح بترسب أية مواد كالأملح أو الخيلر أو القاذورات أو غيرها من المواد على شلال المياه.
- تجنب التلامس المباشر للمعادن أو المواد الأخرى وخاصة الحديد والخرسنة وما إلى ذلك.
- يمكن تنظيف شلال المياه في الأحوال العادية بمياه حمام السباحة غير المعالجة بالكلور. وفي حالة ظهور أول علامات للصدأ يجب تنظيف الأجزاء بمنظف ستنلس ستيل (مادة غير حادة) أو حمض النيتريك في محلول مائي بنسبة 10-15%. وفي الحالتين يجب شطف الأجزاء بمياه عذبة وتخفيفها بقطعة قماش قطنية.
- يجب الانتباه على وجه الخصوص إلى الأسطح البينية (على سبيل المثال: وحدة تثبيت شريط الدايدلت الضوئية) والترسبت على ارتفاع خط المياه.

حريم



GB Cleaning of the stainless steel waterfalls

- Check the waterfall before installation for possible corrosion from, possibly, metals or chemicals not having been noticed initially.
- Start with weekly cleaning to determine and specify the optimum cleaning period. Pay attention that no deposits are formed (e.g. salts or other solids).
- No materials like salts, dust, dirt, etc. are allowed to deposit on the waterfall.
- Avoid direct contact with other metals; especially iron, concrete, etc.
- Cleaning of the waterfall can normally be carried out with not chlorinated basin water. Should first indications of rust have formed, clean the parts with a stainless steel cleaner (No scouring agent) or with nitric acid in a 10-15% water solution. Rinse the parts in both cases with fresh water and dry with a cotton wool cloth.
- Pay special attention to the intermediate areas (e.g. fastening of the LED strip) and deposits at the height of the water level.
- Check the pH-value regularly and pay attention to the correct use of disinfecting agents.
- Circulate the water every day, so that no deposits are formed on the stainless steel parts in contact with water.
- Check the stainless steel waterfall element during an annual preventive maintenance.

D Reinigung der Edelstahl-Wasserfälle

- Vor der Installation eine Kontrolle des Wasserfalles vornehmen, zur Feststellung einer möglichen Korrosion durch ggf. Metalle oder Chemikalien, die zunächst nicht festgestellt worden sind.
- Mit einer wöchentlichen Reinigung beginnen, um den optimalen Zeitabstand herauszufinden und festzulegen. Darauf achten, dass sich keine Ablagerungen bilden (z.B. Salze oder andere Feststoffe).
- Auf dem Wasserfall dürfen sich keine Stoffe wie Salze, Staub, Schmutz, usw. ablagern.
- Den direkten Kontakt mit anderen Metallen oder Materialien vermeiden, insbesondere Eisen, Beton, usw.
- Die Reinigung des Wasserfalles kann normalerweise mit nicht gechlortem Beckenwasser erfolgen. Wenn sich erste Anzeichen von Rost gebildet haben, die Teile mit einem Edelstahltreiniger (kein Scheuermittel) oder mit Salpetersäure in einer 10-15% Wasserlösung reinigen. In beiden Fällen die Teile mit Süßwasser abspülen und mit einem Baumwolltuch trocknen.
- Besonders auf die Zwischenbereiche (z.B. Befestigung der LED-Leiste) und Ablagerungen in Höhe der Wasserlinie achten.
- Den pH-Wert regelmäßig kontrollieren und auf die korrekte Verwendung von Desinfektionsmitteln achten.
- Das Wasser täglich zirkulieren lassen, damit sich an den in Kontakt mit Wasser befindlichen Edelstahlteilen keine Ablagerungen bilden.
- Bei einer jährlichen vorbeugenden Wartung das Edelstahl-Wasserfallelement kontrollieren.

NL Reiniging van de roestvrijstalen watervallen

- Controleer de waterval, voordat u deze installeert, op mogelijke, nog niet eerder vastgestelde corrosie door eventuele metalen en chemicaliën.
- Begin met een wekelijkse reiniging. Op die manier kunt u vaststellen wat het ideale tijdsinterval is. Let erop dat er geen afzettingen gevormd worden (bijv. zouten of andere vaste stoffen).
- Zorg ervoor dat zich geen zout, stof of vuil afzet op de waterval.
- Direct contact met andere metalen of materiaal, met name ijzer, beton, etc. vermijden.
- Het reinigen van de waterval kan in principe met niet gechlorde water uit het bassin gebeuren. Wanneer er tekenen van roest zijn, deze roestplekken met een staalreiniger (geen schuurmiddel) of met salpeterzuur in een 10-15% wateroplossing reinigen. In beide gevallen met zoet water afspoelen en met een katoenen doek afdrogen.
- Controleer vooral de tussenliggende gebieden (bijv. bevestigingen van de ledstrip) en de afzetting ter hoogte van de waterlijn.
- De pH-waarde regelmatig controleren. Gebruik eventuele desinfecteermiddelen op een correcte manier.
- Het water dagelijks laten circuleren, zodat op de roestvrijstalen delen in het water geen afzettingen kunnen ontstaan.
- Bij een jaarlijkse, preventieve onderhoudsbeurt de roestvrijstalen elementen controleren.

F Nettoyage des cascades en inox

- Effectuez un contrôle de la cascade avant l'installation afin de vérifier la présence éventuelle de corrosion par des métaux ou des produits chimiques par ex. et qui ne se verrait de prime abord.
- Commencez par un nettoyage hebdomadaire afin de déterminer l'intervalle optimal entre deux nettoyages. Veillez à ce qu'aucun dépôt ne se forme (par ex. sels ou autres matières solides).
- Aucune substance comme du sel, de la poussière, de la saleté, etc. ne doit se déposer sur la cascade.
- Le contact direct avec d'autres métaux ou matériaux, notamment avec le fer, le béton, etc. doit être évité.
- Le nettoyage de la cascade peut s'effectuer avec de l'eau de bassin non chlorée. Lorsque des premières traces de rouille apparaissent, nettoyer les pièces à l'aide d'un nettoyant pour inox (pas de produits abrasifs) avec ou de l'acide nitrique dans une solution d'eau de 10-15%. Dans les deux cas, rincer les pièces à l'eau douce et les sécher avec un chiffon en coton.
- Veiller particulièrement aux interstices (par ex. fixation de la barre LED) et aux dépôts à hauteur du niveau d'eau.
- Contrôler régulièrement le pH et veiller à utiliser correctement les produits désinfectants.
- Faire circuler l'eau quotidiennement pour éviter la formation de dépôts sur les pièces en inox en contact avec l'eau.
- Inspecter la cascade en inox lors de la maintenance annuelle préventive.

E Limpieza de las cascadas de acero inoxidable

- Antes de la instalación, controle la cascada para detectar una posible corrosión, dado el caso, por metales o productos químicos que al principio no fueron detectados.
- Empiece con una limpieza semanal para encontrar y fijar el óptimo intervalo de tiempo. Tenga cuidado que no se formen incrustaciones (p. ej. sales u otras sustancias sólidas).
- En la cascada no deben acumularse sustancias como sales, polvo, suciedad, etc.
- Evite el contacto directo con otros metales o materiales, en particular, con hierro, hormigón, etc.
- La limpieza de la cascada puede efectuarse normalmente con el agua no clorada del estanque. Si se han formado las primeras señales de óxido, limpie las partes con un limpiador para acero inoxidable (no restregante) o con ácido nítrico en una solución acuosa al 10-15%. En ambos casos, enjuague las partes con agua dulce y séquelas con un paño de algodón.
- Tenga cuidado, en particular, de las zonas intermedias (p. ej. sujeción de la regleta de LEDs) e incrustaciones a la altura del nivel del agua.
- Controle regularmente el valor pH y tenga cuidado de un correcto uso de desinfectantes.
- Deje circular el agua diariamente para que en las partes de acero inoxidable en contacto con el agua no se formen incrustaciones.
- Controle el elemento de acero inoxidable de la cascada durante el mantenimiento preventivo anual.

P A limpeza das cascatas de aço inoxidável

- Antes da instalação, fazer um controlo da cascata para determinar a existência de uma possível corrosão provocada eventualmente por metais ou produtos químicos anteriormente despercebidos.
- Iniciar com uma limpeza semanal para determinar o intervalo de tempo ideal da limpeza. Observe para que não haja formação de sedimentos (p.ex. sais ou outros produtos).
- Sobre a cascata não devem depositar-se elementos como sais, poeira, sujeira em geral, etc.
- Evitar o contacto direto com outros metais ou materiais, principalmente ferro, betão, etc.
- A limpeza da cascata poderá ser feita normalmente com a própria água do tanque não clorada. Ao se notar as primeiras ferrugens nos componentes, elas devem ser eliminadas com uma esponja de lã de aço (não utilizar materiais abrasivos) ou então com ácido nítrico diluído em água a 10-15%. Nos dois casos citados, os componentes devem ser enxaguados com água doce e secados com um pano de algodão.
- Observar principalmente as áreas intermediárias (p.ex. nos pontos de fixação da barra LED) e as sedimentações na altura da linha de água.
- O valor pH deve ser controlado regularmente e atentar para o uso correto dos produtos de desinfecção.
- Deixar circular a água diariamente para que não se formem sedimentos nos componentes de aço inoxidável que tem contacto com a água.
- Fazer o controlo do elemento de aço inoxidável da cascata durante a manutenção preventiva anual.



www.ubbinkgarden.com



