

- Strainer** : COOLING WATER STRAINER, type FTR1900
- Application** : To filter the raw water before it is fed into the cooling system of a marine engine.
- In case of an indirect cooled engine it will prevent fouling of the raw water pump and heat-exchanger.
- In case of a direct cooled engine it will prevent fouling of the raw water pump and the engine's cooling system.
- Material,**
- housing** : Polyethylene
 - strainer element** : Stainless steel
 - lid** : PMMA (Acrylic)
- Strainer element,**
- total area** : 888 cm² (137 sq.in.)
 - open area** : 266 cm² (41 sq.in.)
 - hole size** : 3 mm diam. (approx. 1/8 in.)
- Weight** : 3.8 kg (8 lbs 6 oz)
- Max. ambient temperature** : 75°C (167°F)
- Max. water temperature** : 55°C (131°F)
- Max. pressure** : 0.5 bar (7 psi)
- Relevant CE Standards** : Non
- Classification** : Non

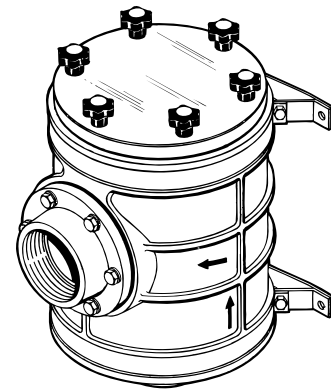

Model	Connection	For hose	Recommended capacity in normal use		
			l/min	Imp (UK) gal/min	US gal/min
FTR190063	G 2 1/2	63 mm (2 1/2")	570	125	150
FTR190076	G 3	76 mm (3")	820	180	217

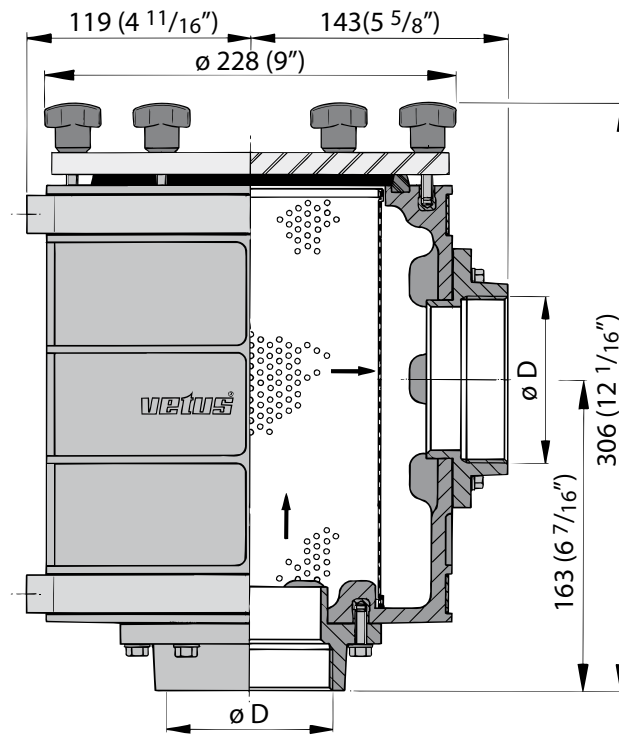

FTR1900

Overall dimensions