

AIR POWER

ENGINE CAR KIT

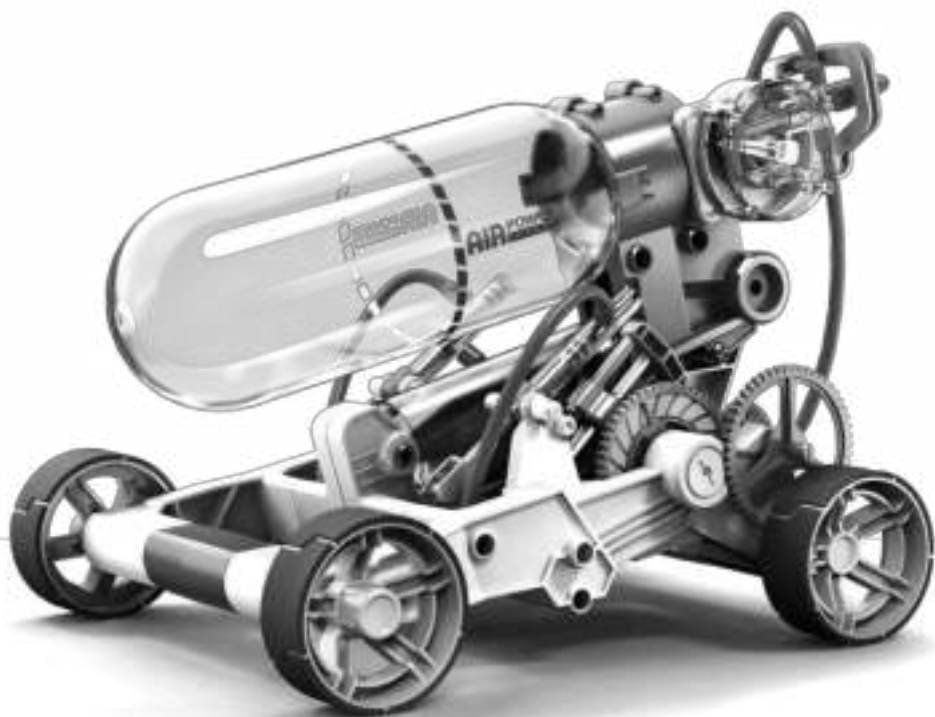

Assembly & Instruction
Manual



AIR POWER ENGINE CAR

Product Introduction

Gasoline is currently the fuel of choice, but petroleum used to make it is becoming increasingly difficult to find and is contributing to environmental issues and worldwide problems. Automobile manufacturers know this and are spending tremendous amounts of money to develop alternative fuel for the future. Let us introduce you another alternative fuel and eco-friendly vehicle - Air Power Engine Car.

Air as fuel... could possibly be another alternative to petroleum. Air is available 24/7, does not run out and it's free. By golly, we might have something here and Air Power Engine Car can break down this technology to its simplest form. This is an amazing kit that uses the vision of our ancestors back in the middle of the 19th century. Now, your child can bring that vision to life and gain valuable insight into propulsion via compressed air.

Assembly and operation is a breeze. A pump-up bar with a pressure meter is built into the car for easy operation. This meter measures the volume of compressed air. The air chamber made from PET (polyethylene terephthalate). The silicon tube (red in color) creates an air tight fit. Another safety device implemented into the kit is a safety valve. If the user keeps pumping while the tank is full, the safety valve will open and bleed the air automatically. Anyway, back to the air in the tank. When the air chamber is full, you can release the compressed air; the air then expands and drives the vehicle a distance up to 50 meters in 35 seconds. The car is fast and furious fun that requires no batteries or specific weather conditions to limit its usage. Air Power Engine Car is not only designed with the environment in mind, but is also fun and easy to build!

Tools You May Need

Diagonal Cutter

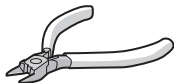

Screwdriver



Hammer

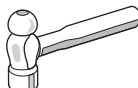

Scissors



Permanent Marker



Ruler





Tissue Paper

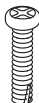

Mechanical Parts List

! Product contains functional edges and sharp points.

P1	Tapping Screw	QTY
		20

P2	Tapping Screw	QTY
		6

P3	Round Shaft	QTY
		1

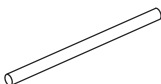
P4	Round Shaft	QTY
		1

P5 Round Shaft	
	QTY
	1

P6 Hex Shaft (Short)	
	QTY
	1

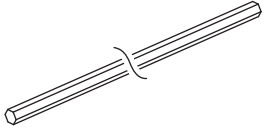
P7 Hex Shaft (Long)	
	QTY
	1

P8 Spring	
	QTY
	1

P9 O-ring (Black)	
	QTY
 (Spare part : 1 pc)	2

P10 Red Cap (Small)	
	QTY
 (Spare part : 1 pc)	7



P11 Red Cap (Medium)	
	QTY
	2

P12 Red Cap (Big)	
	QTY
	1

P13 Spacer	
	QTY
	1

P14 Bottle Top	
	QTY
	1

P15 Silicon Tube	
	QTY
	1

P16 Oil Bag	
	QTY
	1
 Do not touch the oil while fitting the silicon tube.	

P17 Valve (Clear Blue)	
	QTY
 (Spare part : 1 pc)	2

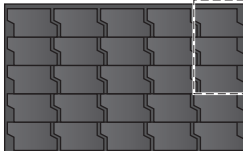
P18 Sponge	
	QTY
 Spare parts	1

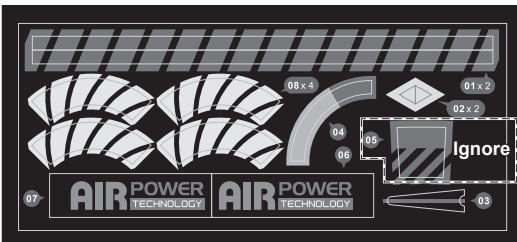
P19 Sticker	
	QTY
 07 AIR POWER TECHNOLOGY AIR POWER TECHNOLOGY 08 x 4 01 x 2 02 x 2 04 05 Ignore 06 03	1

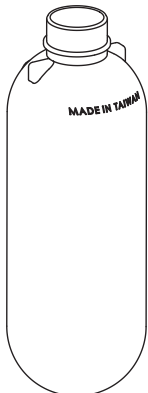
P20 PET Bottle	
	QTY
 MADE IN THAILAND	1

Plastic Parts

! Cut the plastic parts when they are required.
Do not cut them in advance.

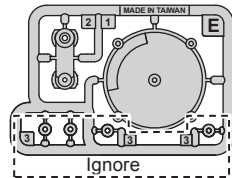
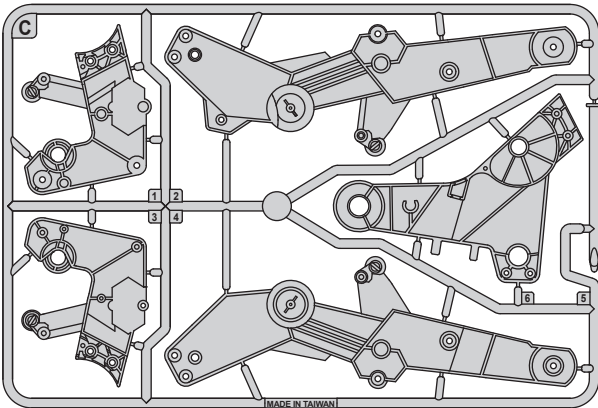
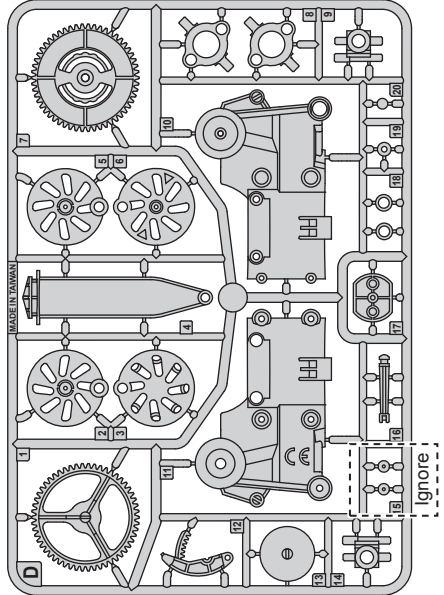
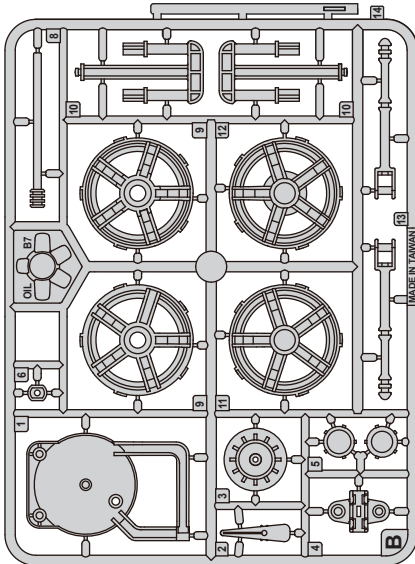
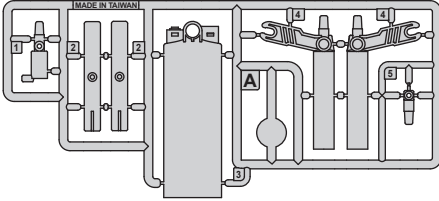

Tip : Cut Off The Burrs Before Assembly

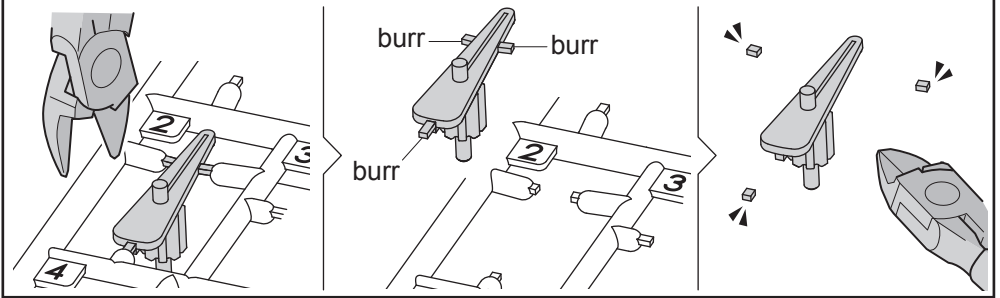

How To Fit Air Tube

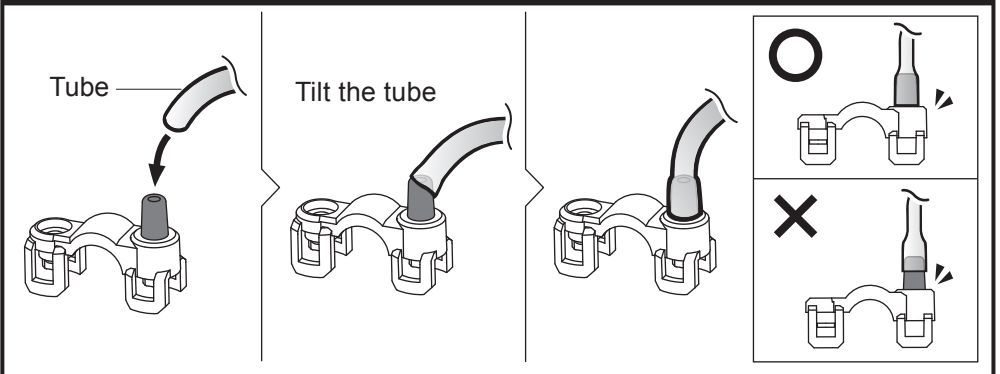

How To Cut Air Tube

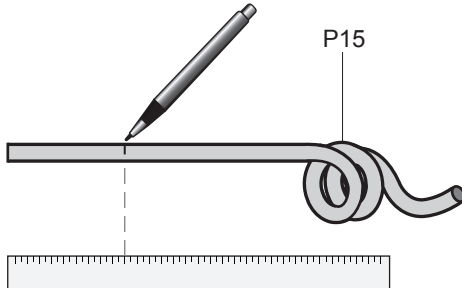
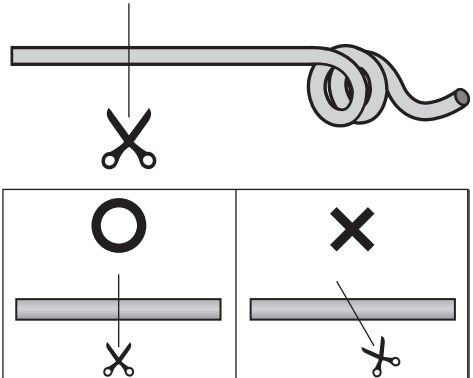
<h3>1 Measuring & Marking</h3>  <p>! Follow the steps above, cut the air tubes when they are required. Do not cut them in advance.</p>	<h3>2 Cutting</h3> 
---	---

Tube Module A Assembly

1

! Prepare air tube before assembly.

Scale
1:1

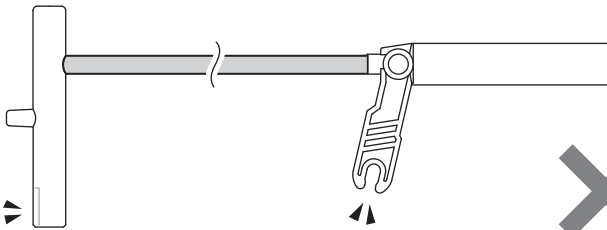
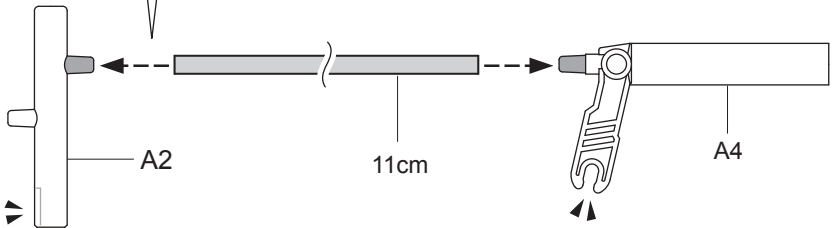
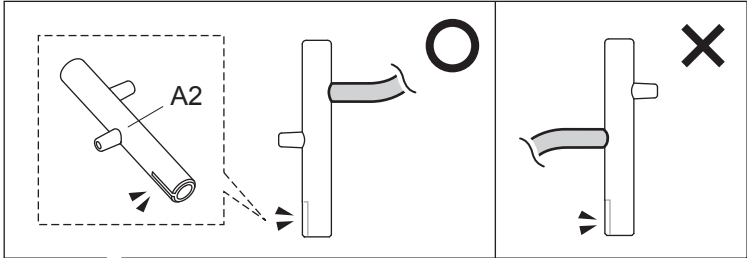

x2

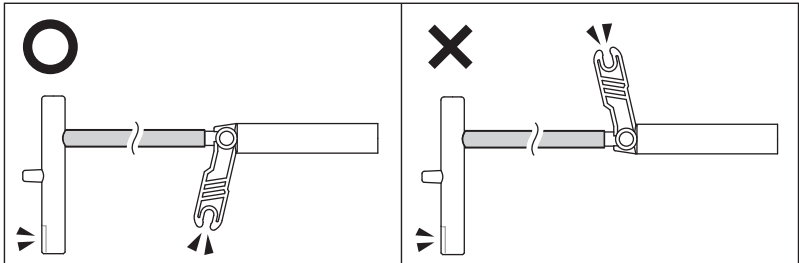

x2

2

! Prepare air tube before assembly.

Scale
1:1

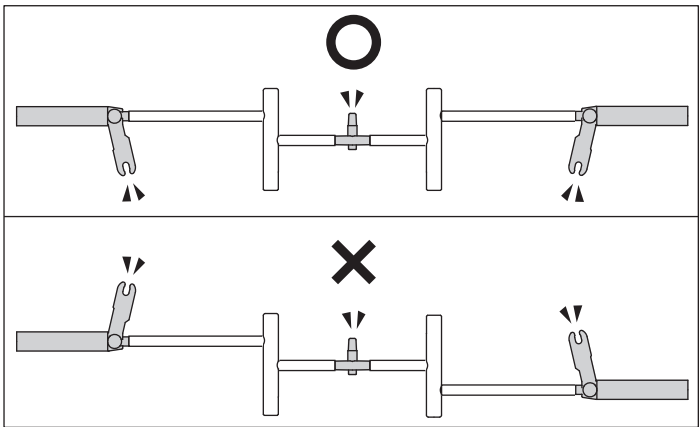
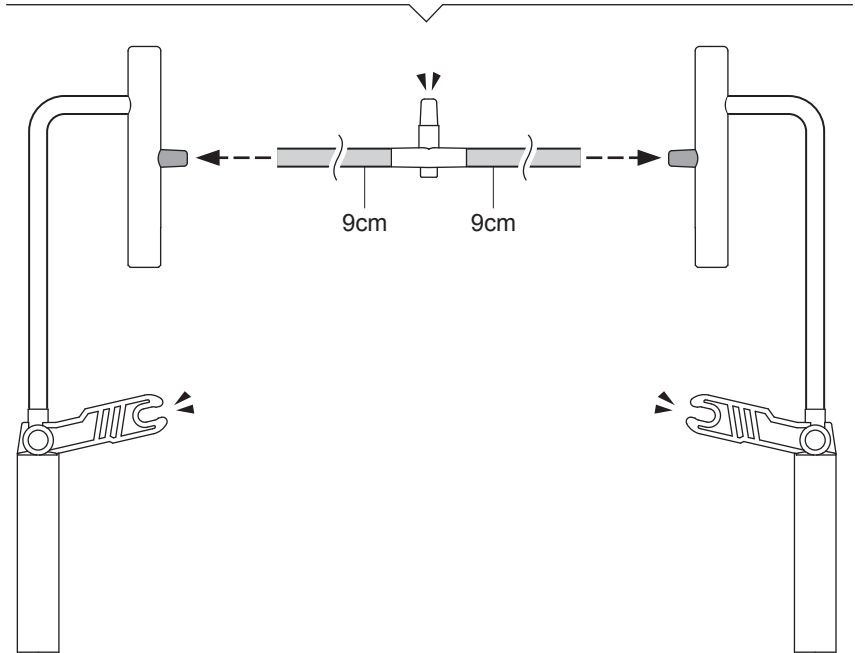
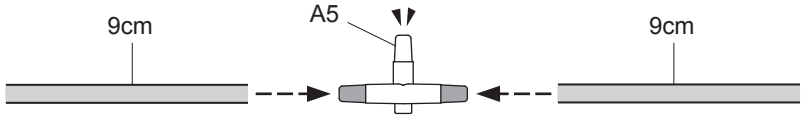

x2

Tube Module B Assembly

Scale
1:1

1

! Prepare air tube before assembly.

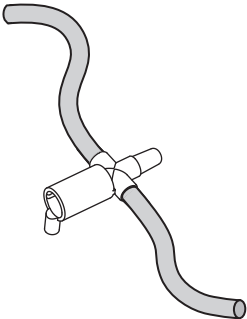
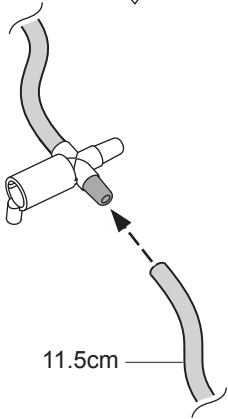
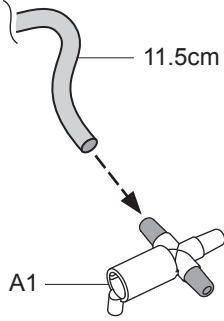

x2

Scale
1:1

2

! Prepare air tube before assembly.

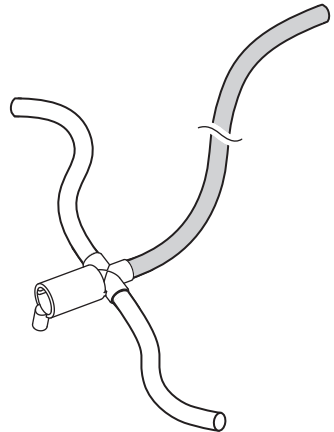
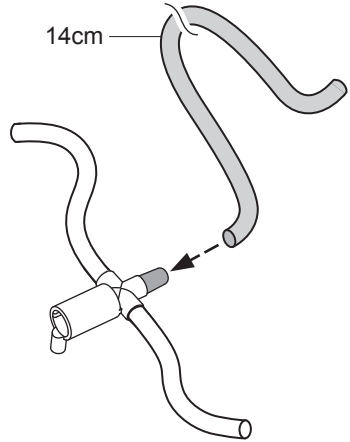

x1

3

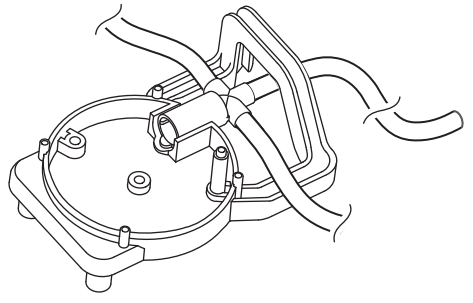
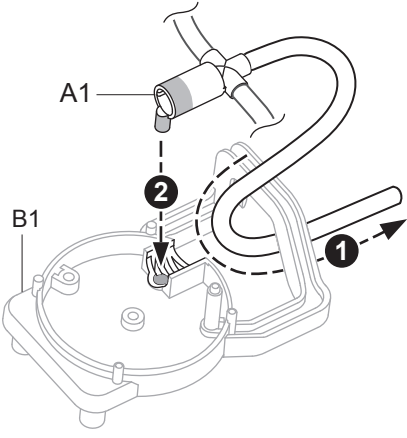

4

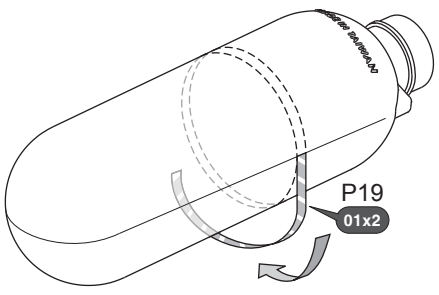
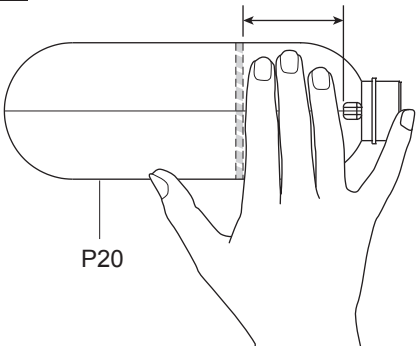

5

! Screw P14 to PET bottle tightly to avoid air leakage.

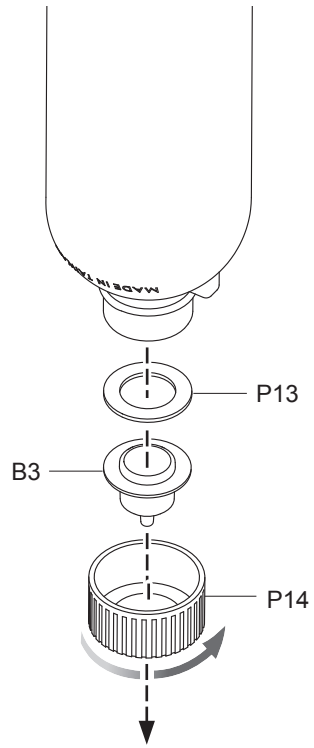

6

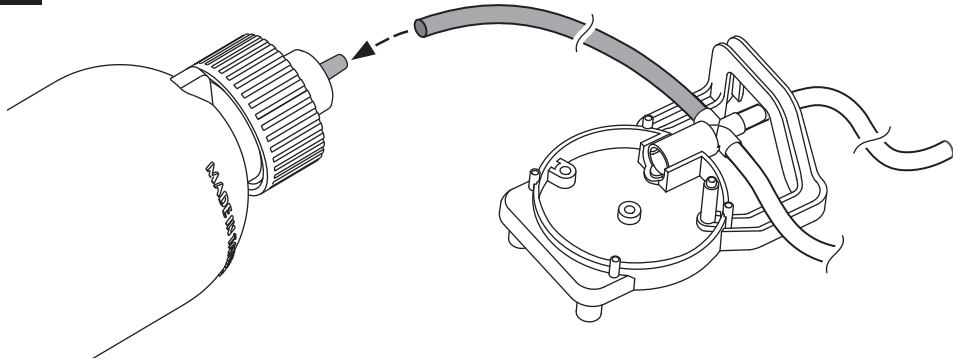

How To Oil The Parts

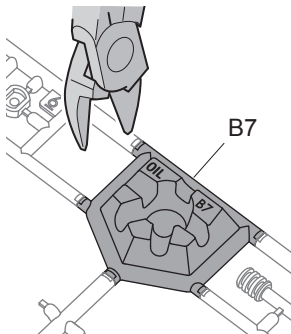

Tissue Paper

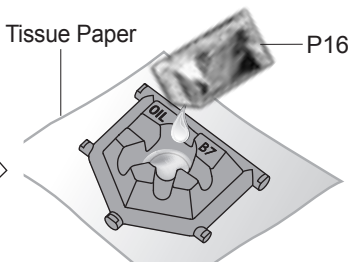

Do not spill any oil from the B7 oil sink. Keep oil contained.

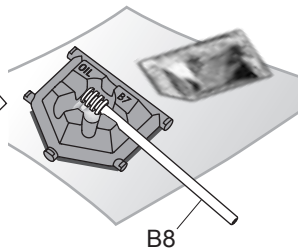

= Apply Oil

Note : Oil the parts when  appears.



Do not oil outside the shadow as shown below.

Example:

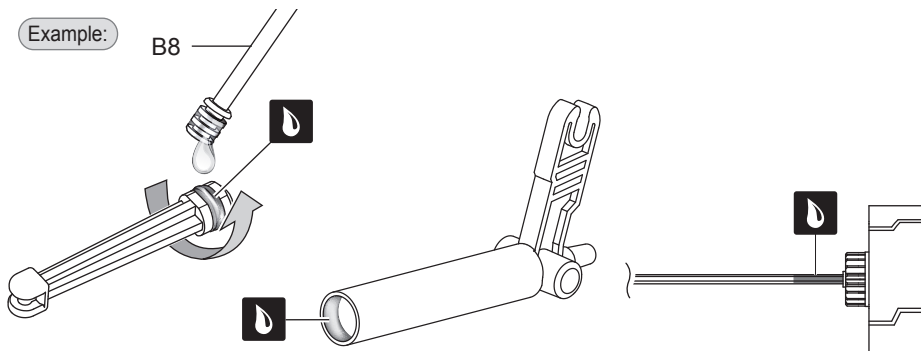

Video Tips

<https://youtu.be/m mzSFocksso>



Scanning the QR code to help you assemble below steps smoothly.

7  Make sure P10 is placed in the proper direction to avoid air leakage.

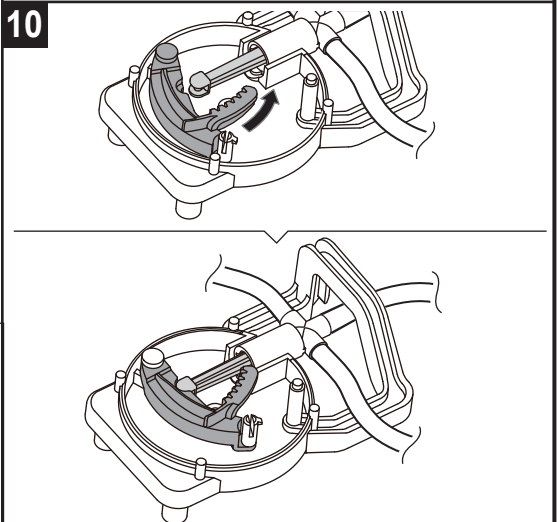
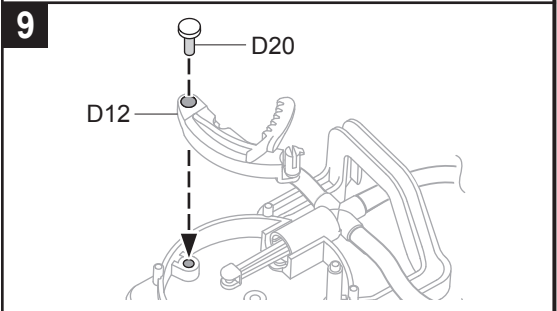
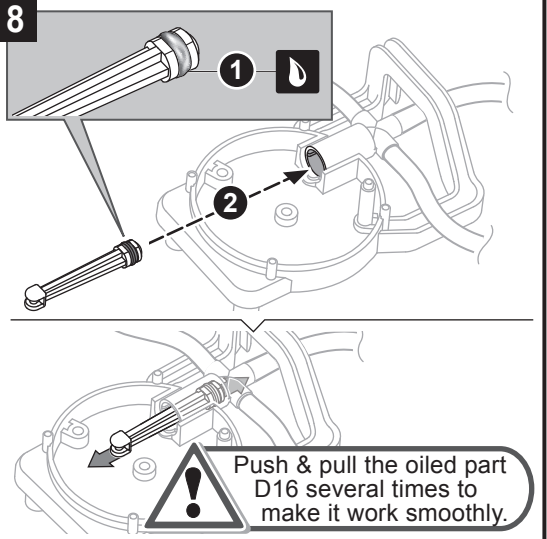
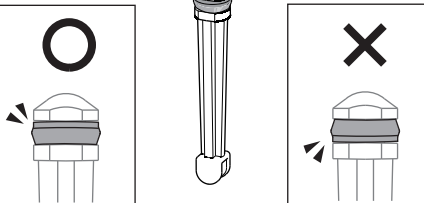
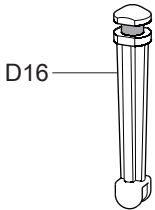
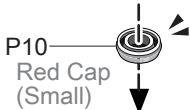
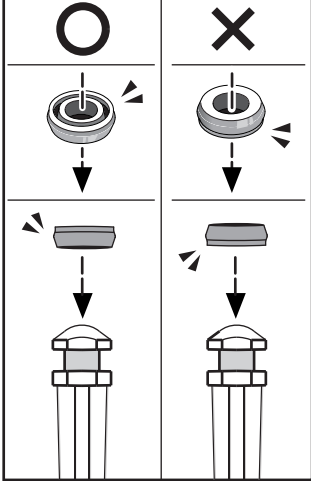

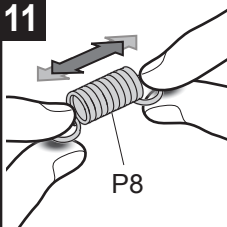
11

P8

Note:

Give a slight pull on both ends of the spring to make sure of good strength & extension before assembly.

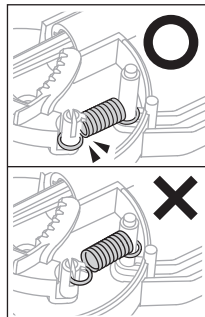
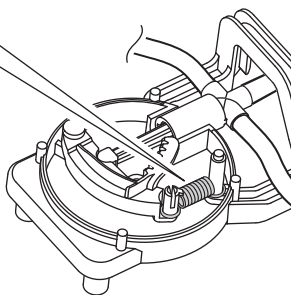
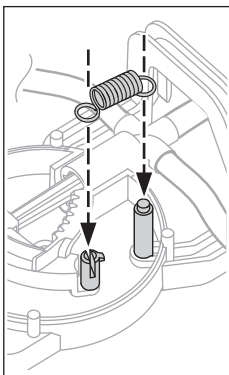
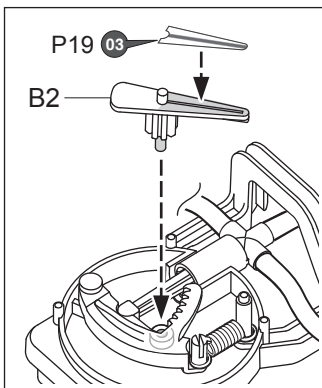
**12**

P19 03

B2

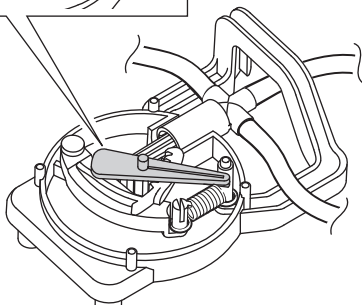
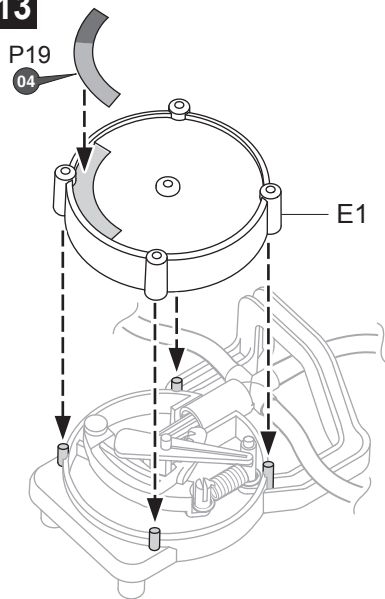
**13**

P19 04

E1

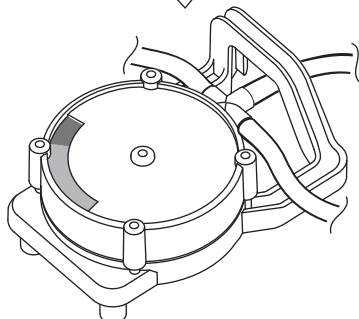
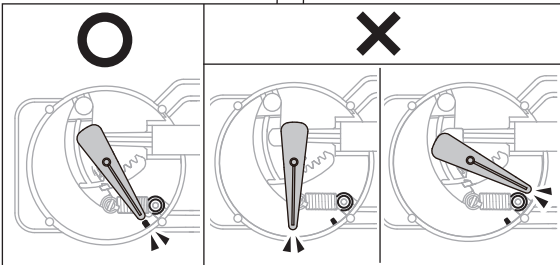

Valve Assembly

Video Tips <https://youtu.be/B2I8FHszic>



Pay close attention to the following steps correctly to avoid air leakage.

Scanning the QR code to help you assemble below steps smoothly.

1 C5
E2
P9 O-ring (Black)

! Use C5 to assist you in setting P9 to E2 entirely.

2 P9 O-ring (Black)
A3

3 P17

! Ensure the direction of two P17 to avoid air leakage.

4 E2
A3

1 Straight A3 on the table, and put E2 on A3 flatly.

2 Press down E2 to A3 entirely.

5 B14
P4

! Straight P4 on the table, cap B14 to P4 as shown.

6 B14

! Use B14 to assist you in setting two P9 entirely.

Push P17 to the bottom (as per Fig 1) and make P9 to set flatly.

Push P17 to the top (as per Fig 2) and make P9 to set flatly.

! If P9 (O-Ring) was set improperly as shown in above wrong fig, re-do step 6 again.

Video Tips

<https://youtu.be/Jgh963Gc2i0>



Scanning the QR code to help you assemble below steps smoothly.

Air Leakage Testing – The Valve

1

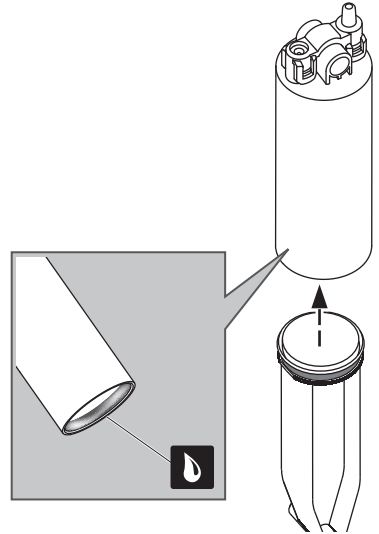
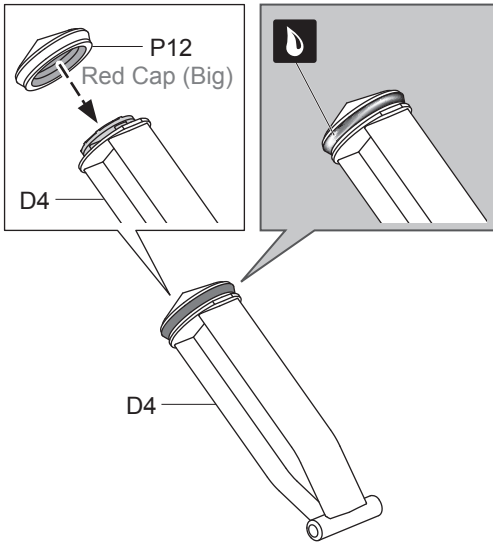

2

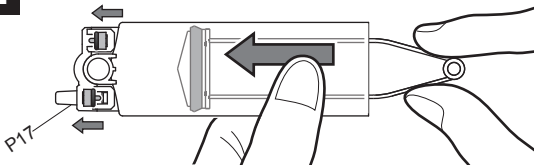

Make sure that both P17 move to the direction indicated by the arrows when the D4 is pushed in.

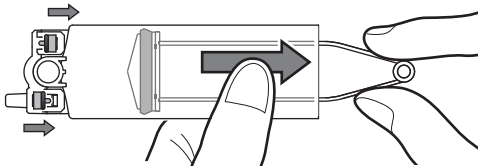

Make sure that both P17 move in the direction indicated by the arrows when the D4 is pulled back.

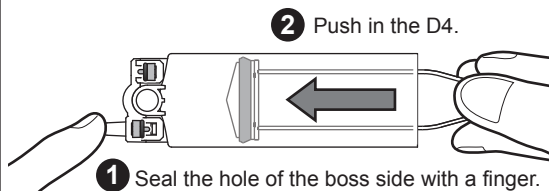

Confirm that the D4 cannot be pushed in easily.

1 Seal the hole of the concave side with a finger.

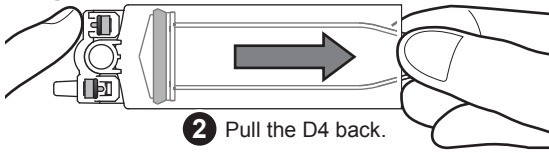

2 Pull the D4 back.

Confirm that pulling the D4 back is hard, or you need more power to pull the D4 back.

Air leakage testing – Tube Module B

1

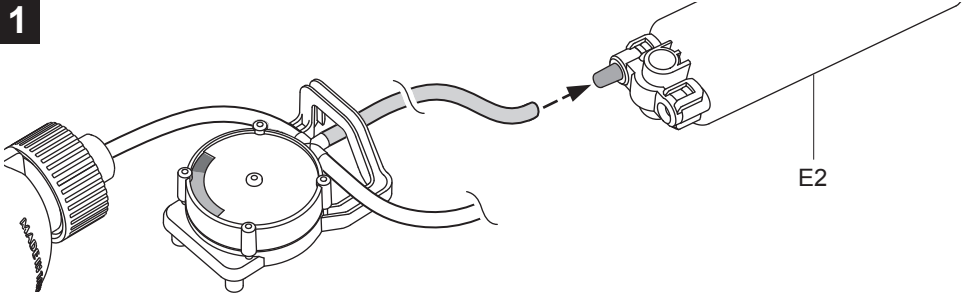

E2

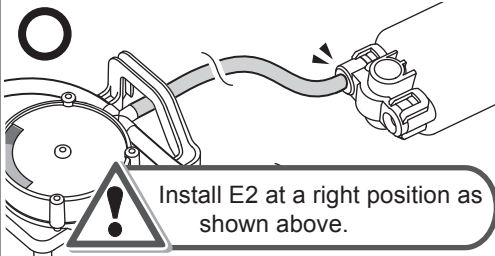

Install E2 at a right position as shown above.

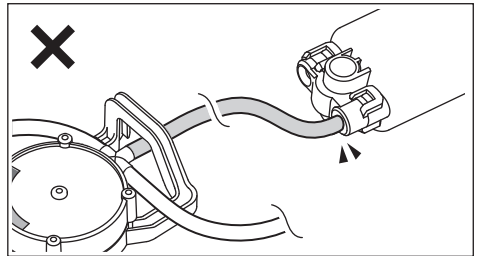

2

! Fold the tube and insert it to the hole as shown below.

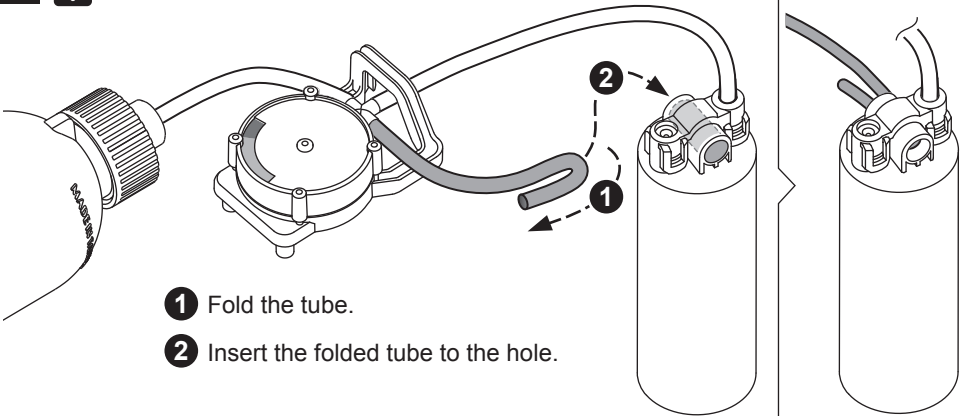

1 Fold the tube.

2 Insert the folded tube to the hole.

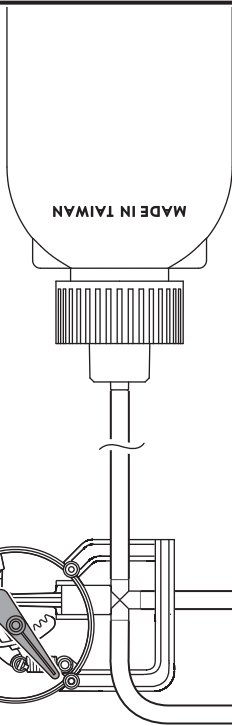
3

Hold A3 firmly!

Repeat a “ Push & Pull” movement using D4 15~20 times to collect air into PET bottle.

Check pressure meter and examine the position that the pointer swings to.

Results shown below will reveal if tube module B is installed functionally or experiencing air leakage.

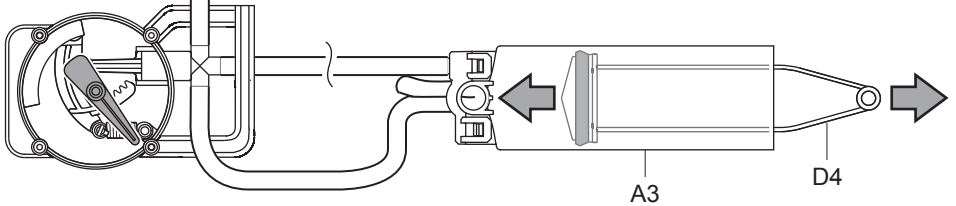

Air Leakage

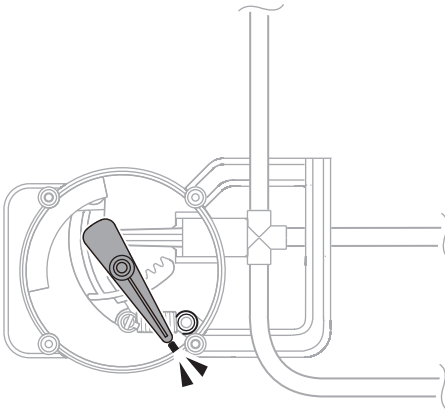

Pointer stays still

Working Functionally

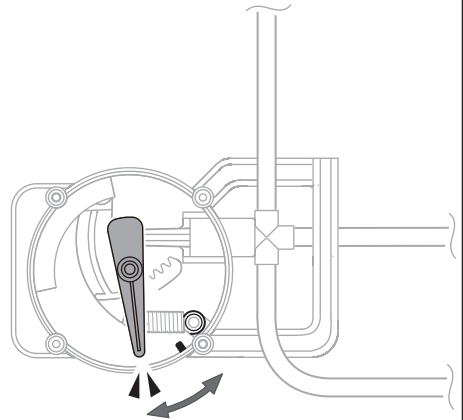

Pointer turns to above position

4

Check following positions if air leakage was occurred, and re-install as below:

MADE IN TAIWAN

Position 1:

Position 1:

Back to page 8, and re-install step 5 again.

Position 2:

Back to page 10, and re-install steps 7~13 again.

Position 3:

Back to page 12, and re-install steps 1~6 again.

Position 2:

Position 3:

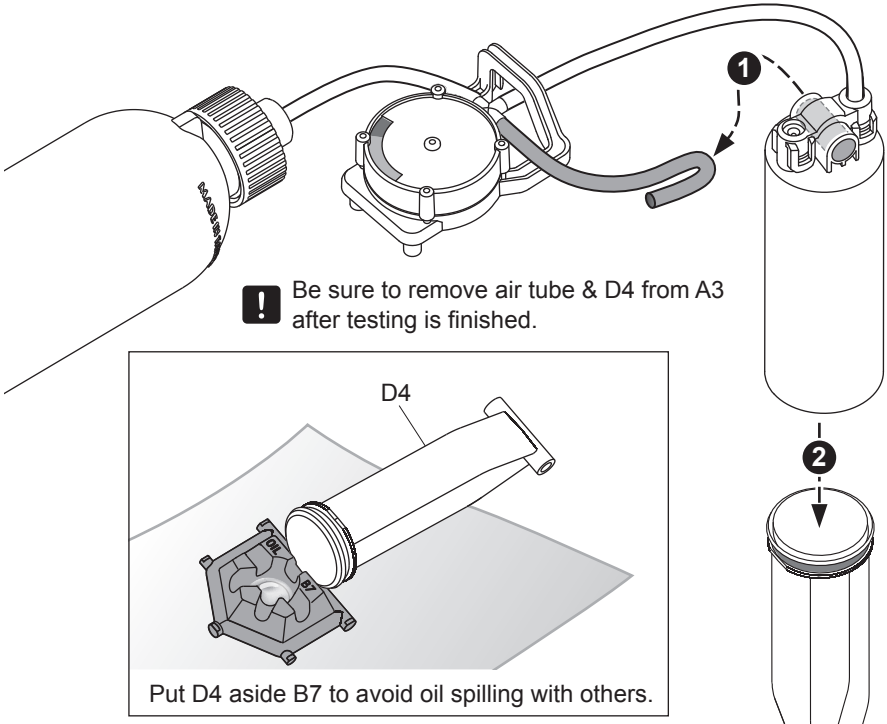

Vehicle Body Module Assembly

1

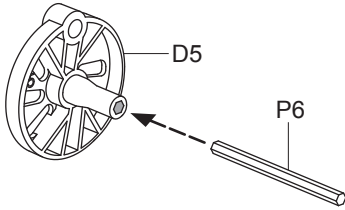

! Insert P6 hex shaft to the bottom as indicated on the right fig. (scale 1:1)

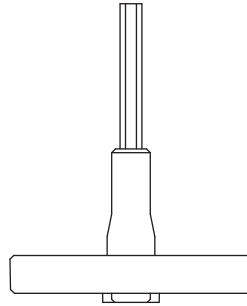

Scale 1:1

2

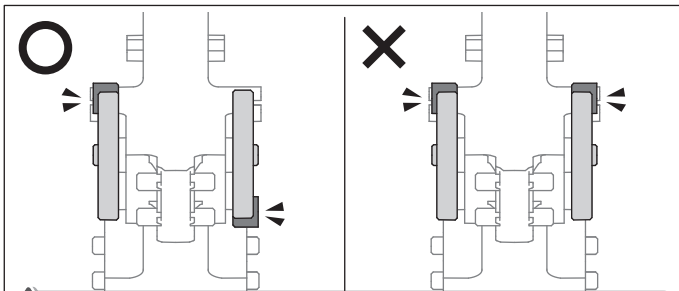
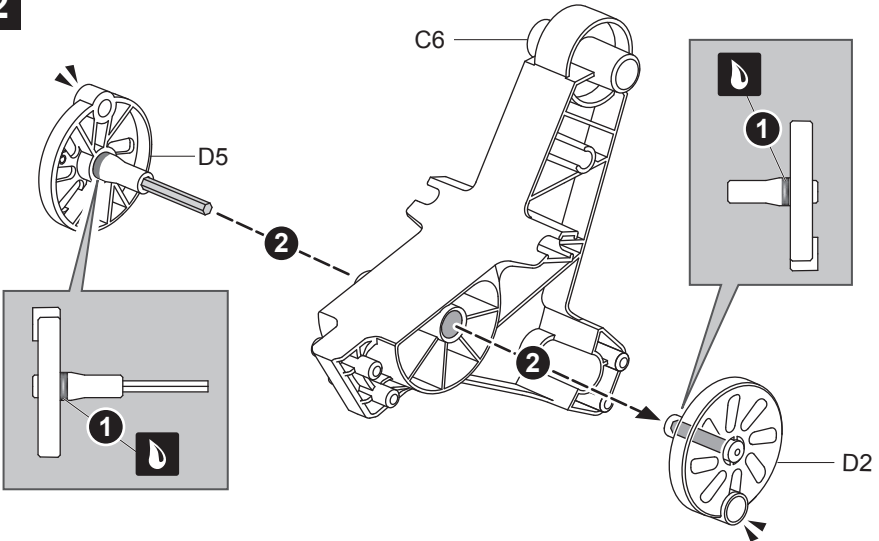

Make sure parts D2/D5 are at opposite positions.

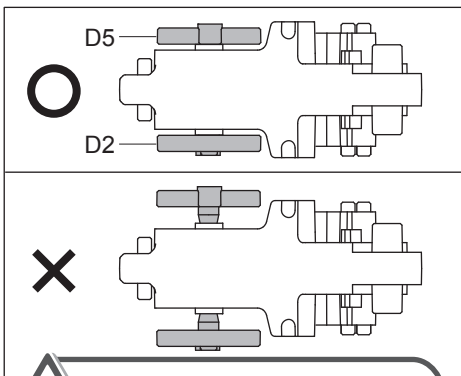
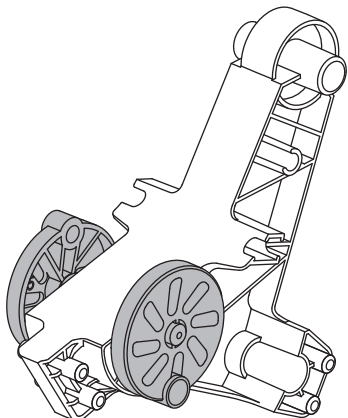

Push parts D5 & D2 to the bottom as shown above.

3

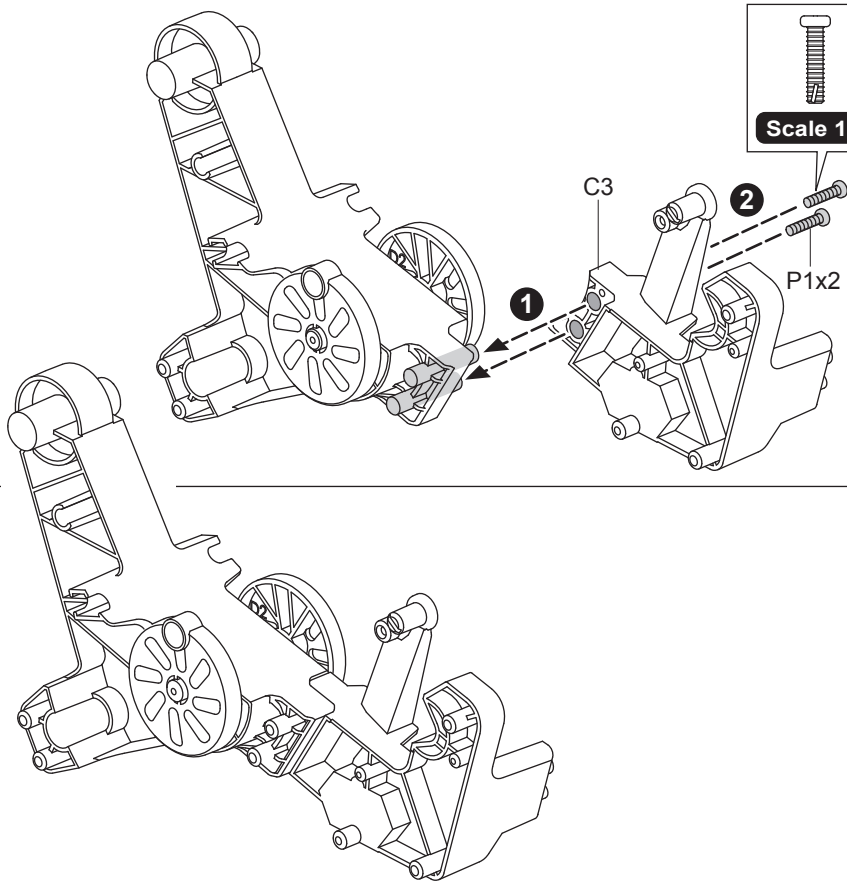

4

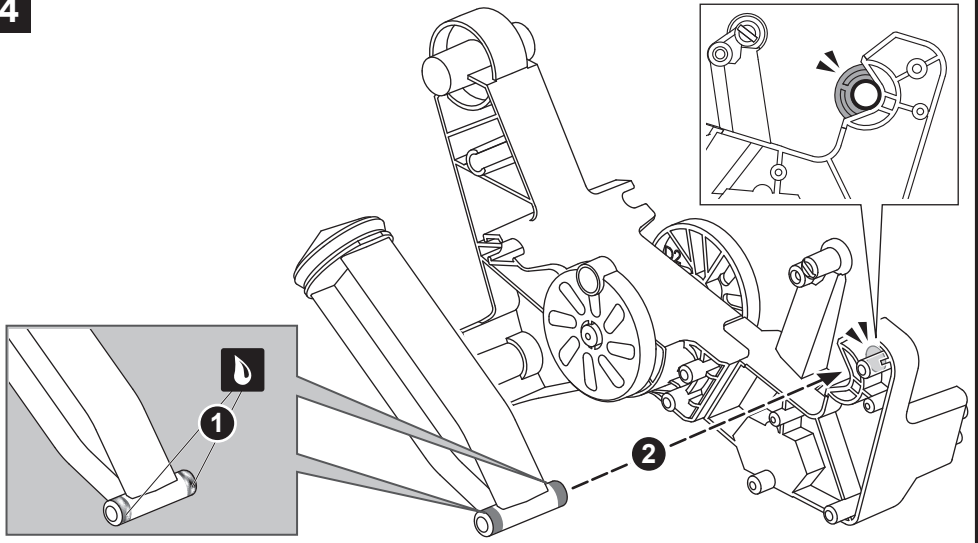

5

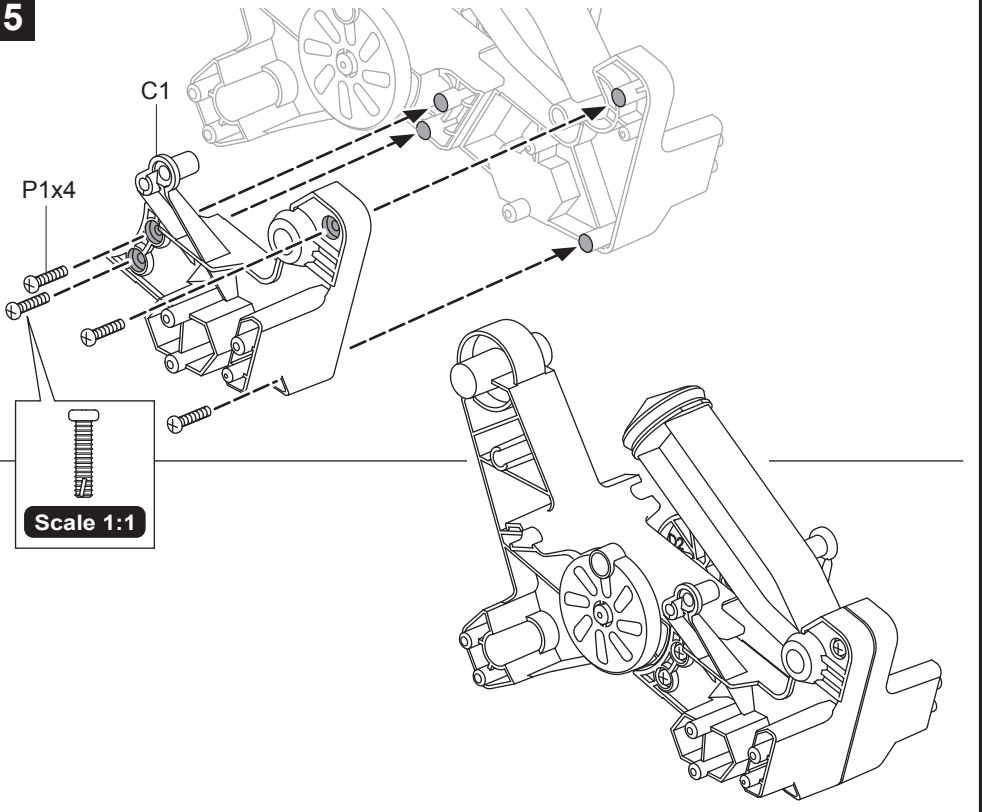

6



! Cut off the burrs before assembly.

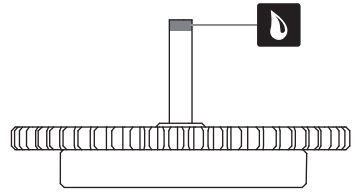
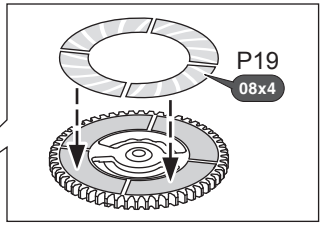
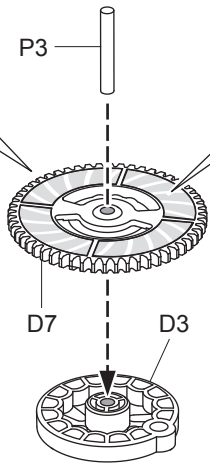
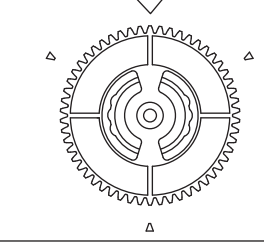
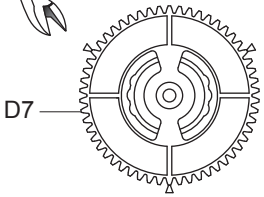

Scale 1:1

! Insert P3 to the bottom to match fig shown above. (scale 1:1)

7

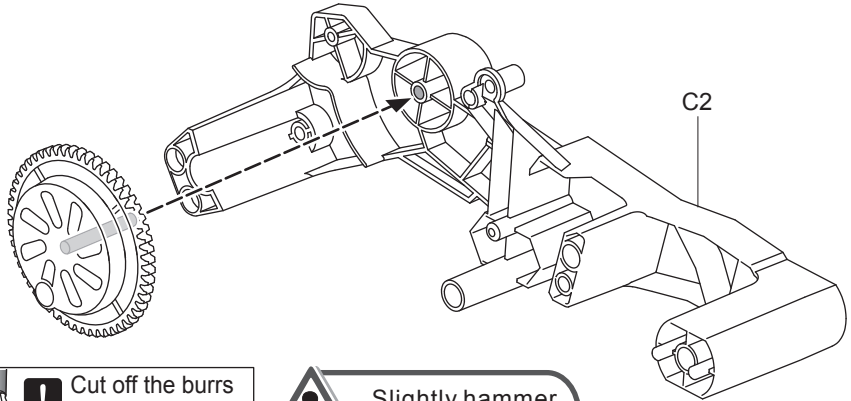

8



! Cut off the burrs before assembly.

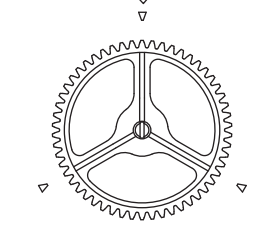
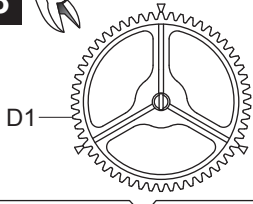

! Slightly hammer P5 into D1.

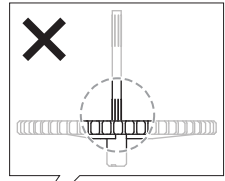
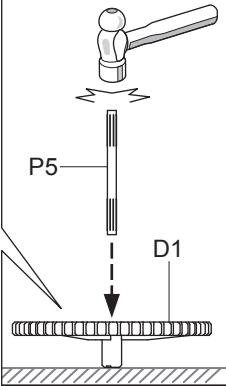

Scale 1:1

! Insert P5 to the bottom to match fig shown above. (scale 1:1)

9

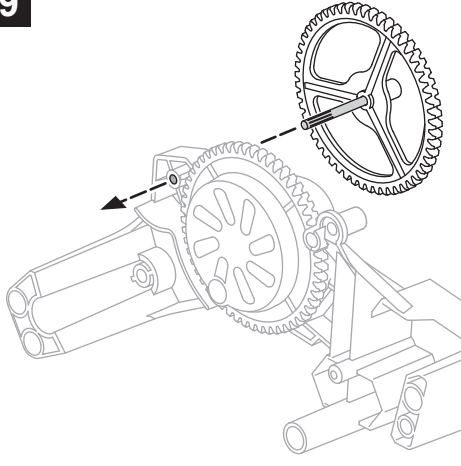

10

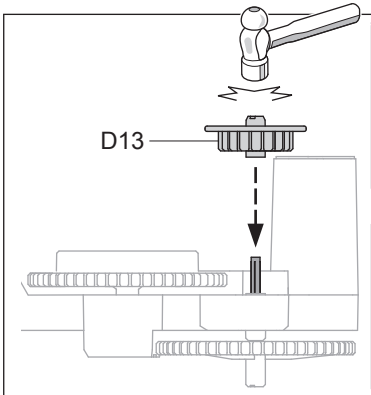
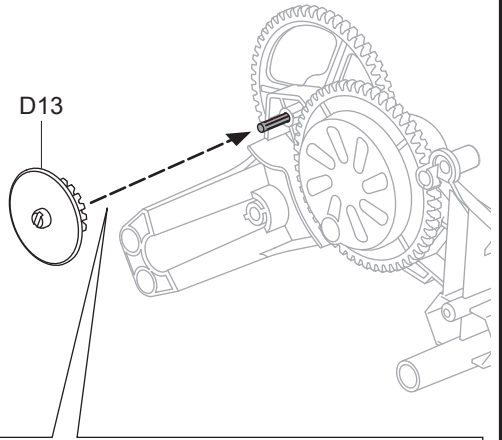

Slightly hammer D13 to the bottom as shown below.

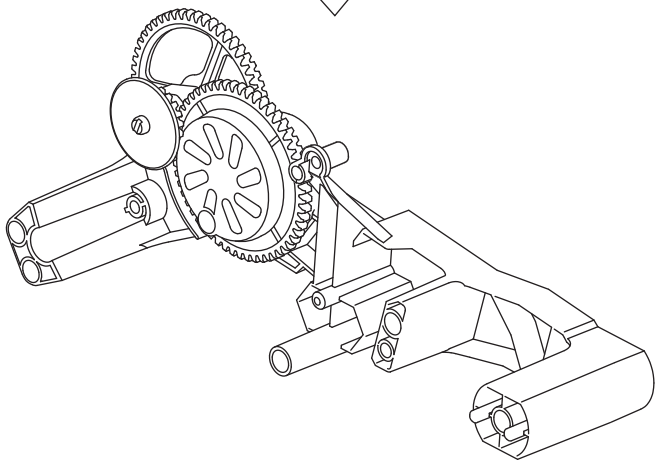
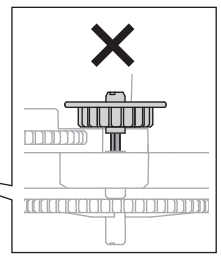
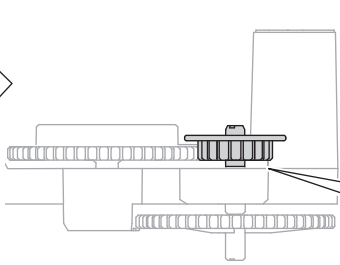

Video Tips

<https://youtu.be/-mpxMk3G22A>



Scanning the QR code to help you assemble below steps smoothly.

Make Sure P10 Set To B13 Step By Step As Shown Below.

11



Ensure P10 is inserted in the proper direction to avoid air leakage.

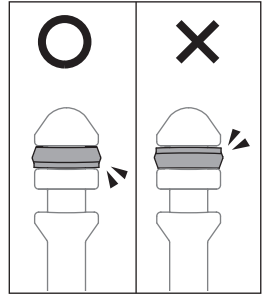
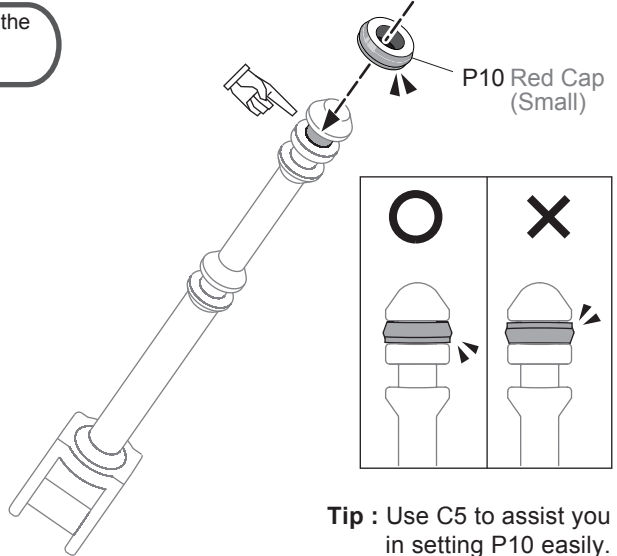
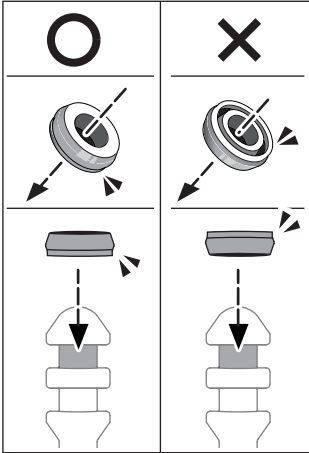

Tip : Use C5 to assist you in setting P10 easily.

12



Ensure P10 is inserted in the proper direction to avoid air leakage.

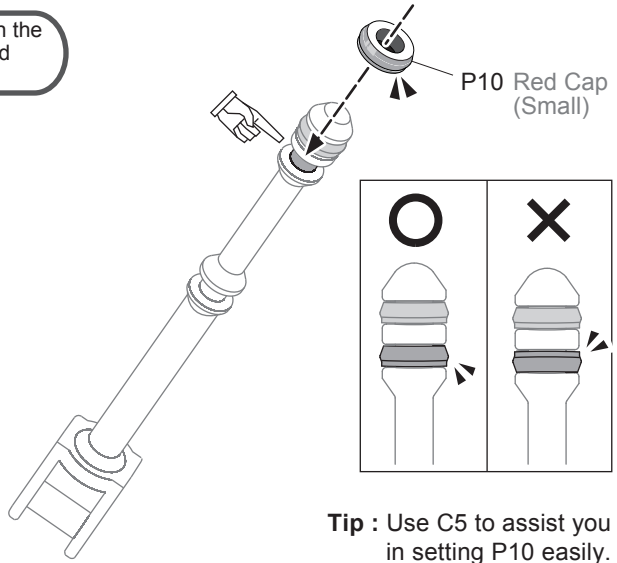
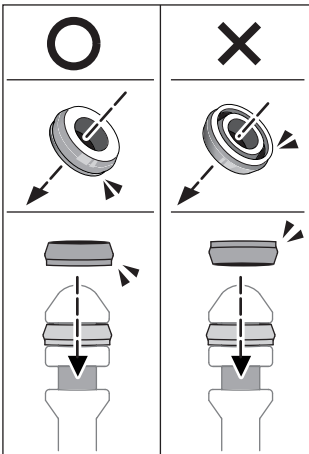

Tip : Use C5 to assist you in setting P10 easily.

13

Ensure the direction of P10 to avoid air leakage.

Note: Direction of P10 on step 13 is different from step 11 & 12.

P10 Red Cap (Small)

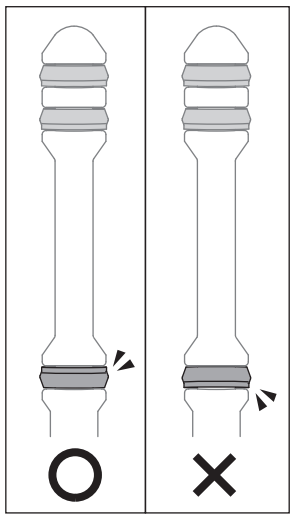
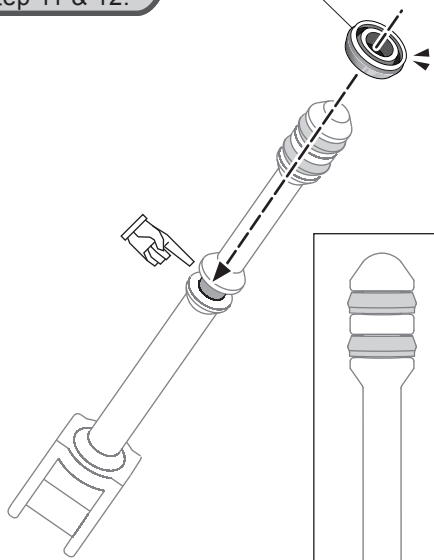
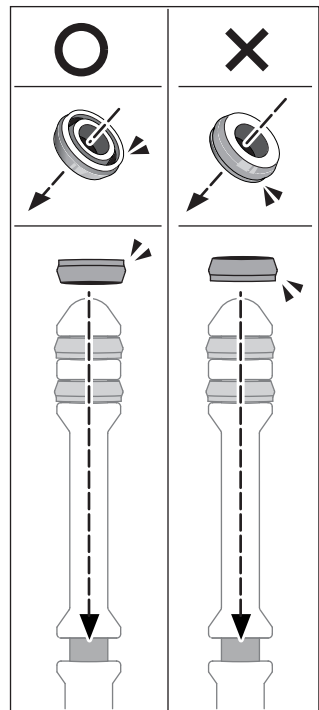

Tip : Use C5 to assist you in setting P10 easily.

Tip :

Use C5 to make it smooth if P10 was twisted during assembly.

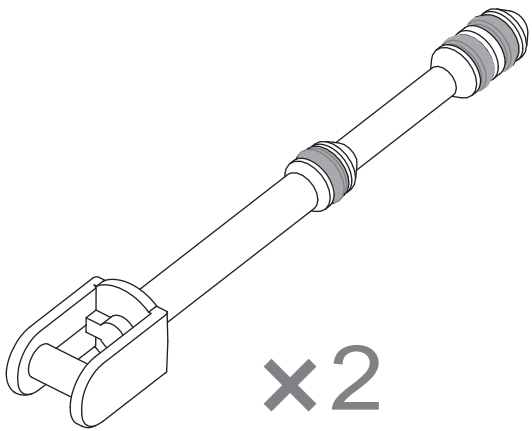
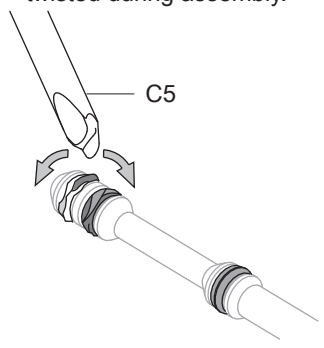

14

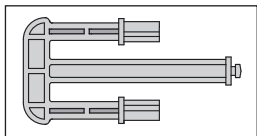

P11
Red Cap
(Medium)

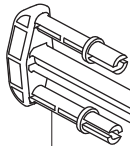

B10

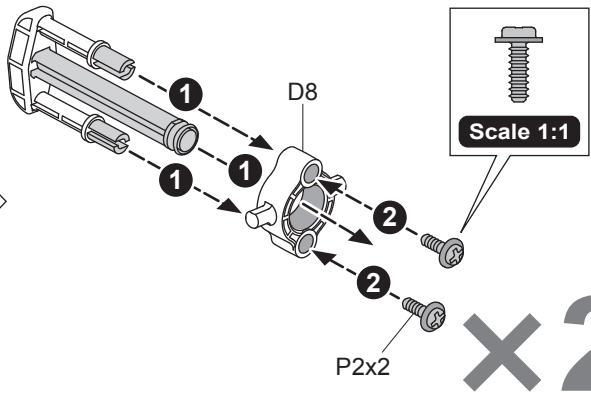

Scale 1:1

P2x2

x2

15

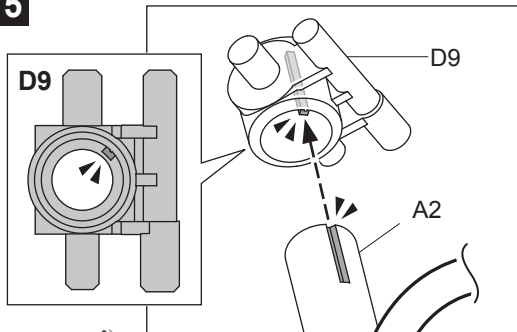

D9

D9

A2

Note:
Make sure to lock A2 / D9 entirely.

Do not mix up D9 & D14, make sure to use D9 for assembly.

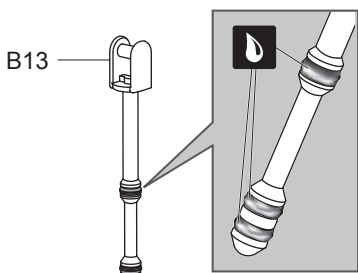

B13

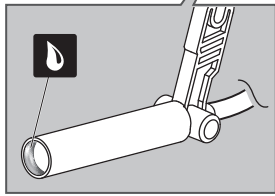
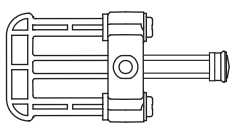

**Take off B13 if P10(Red Cap) was twisted during assembly.
Re-insert B13 to A2 after P10 was re-set flatly.**

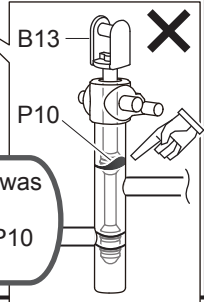

B13

P10

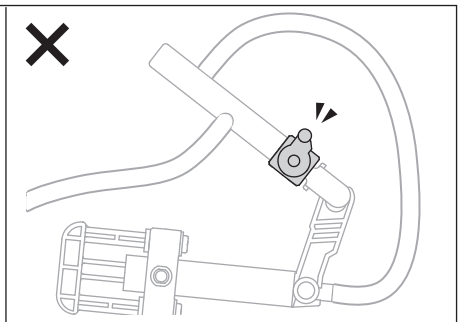
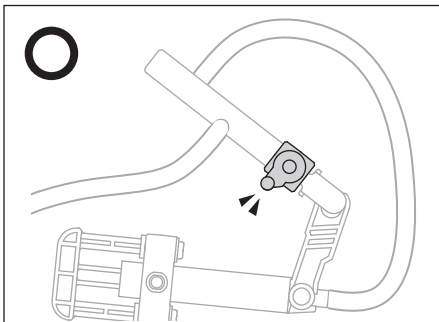
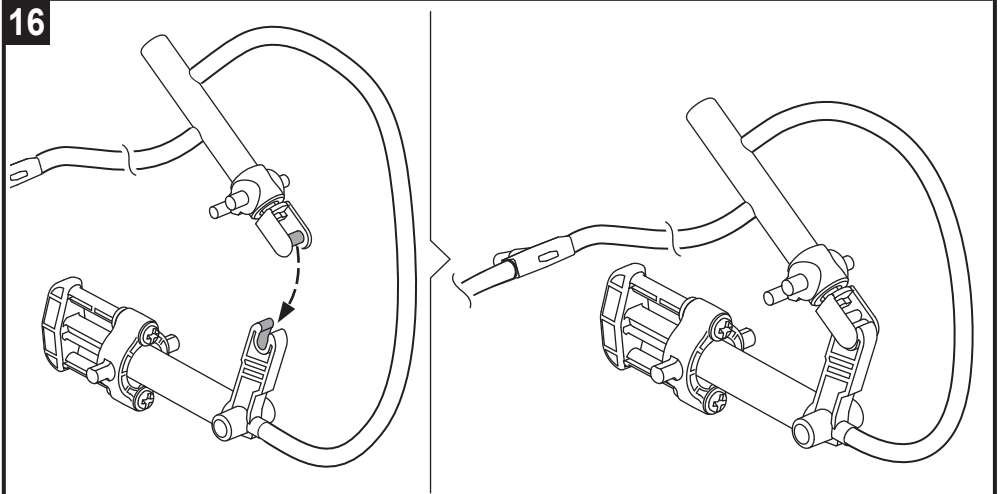
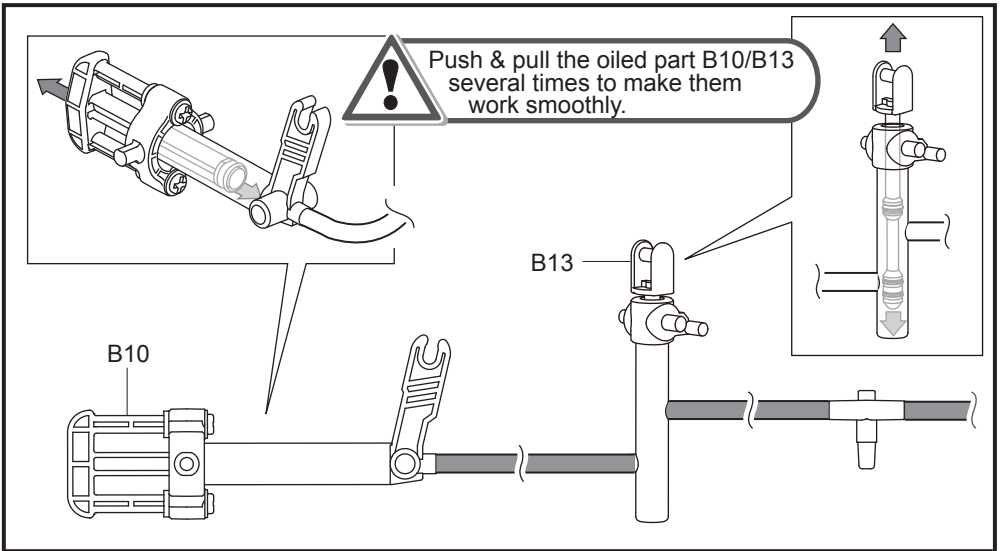

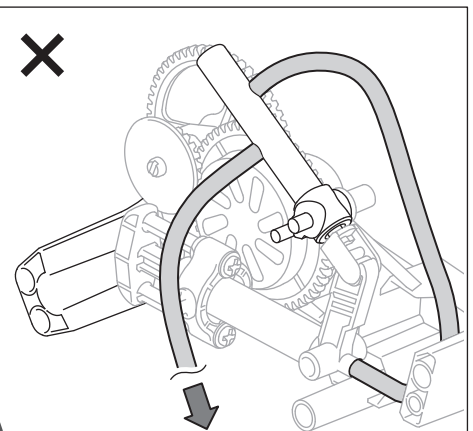
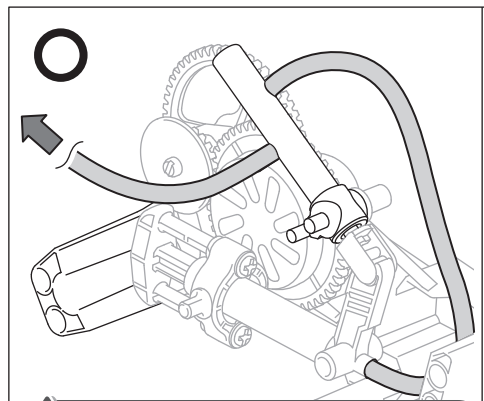
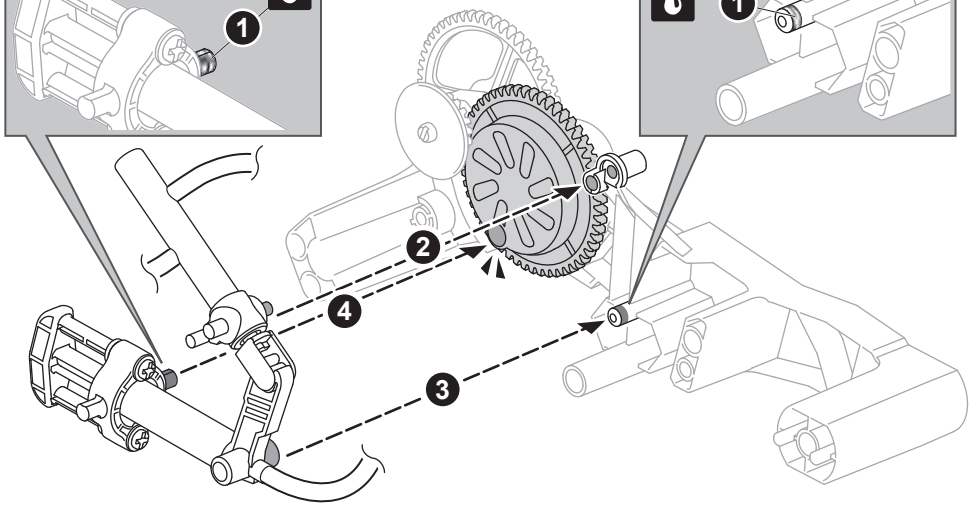
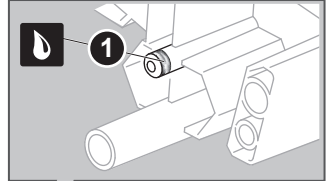
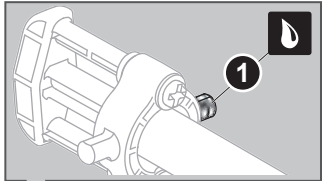
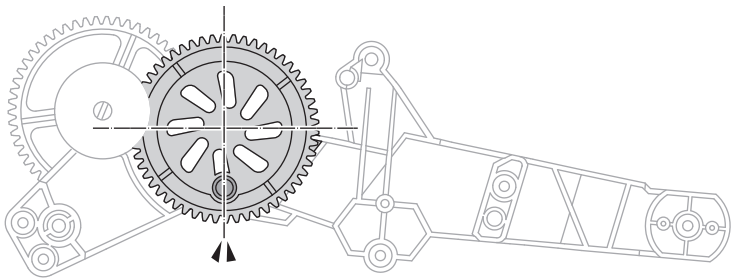

 Route the air tube and have it at the right position as shown above.

18

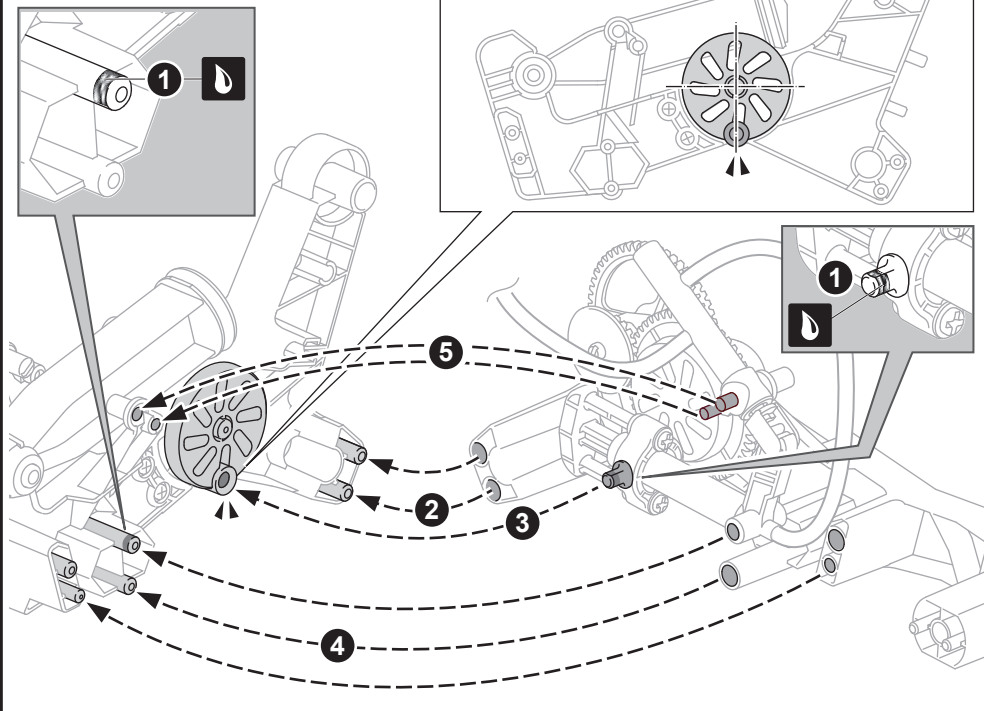

19

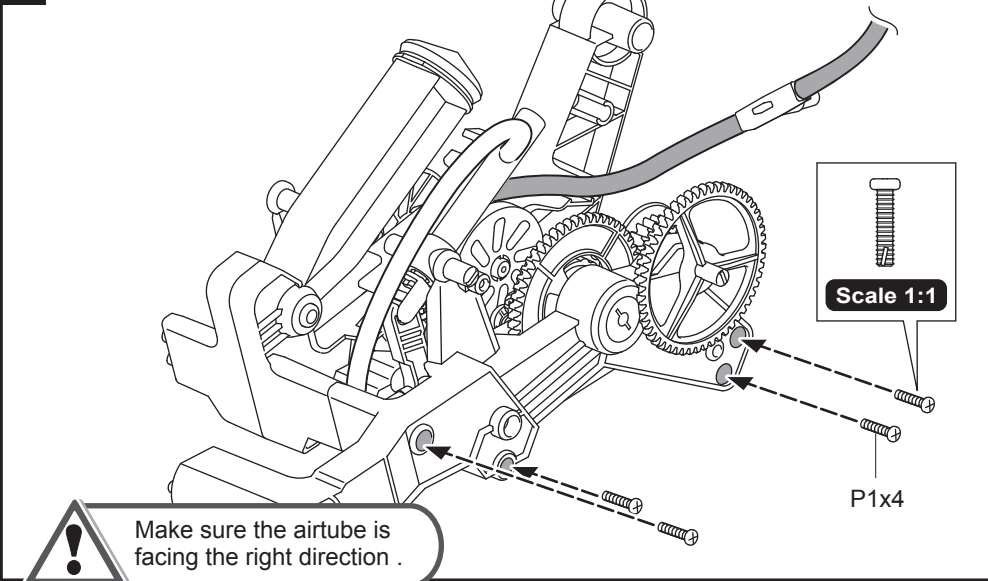

20

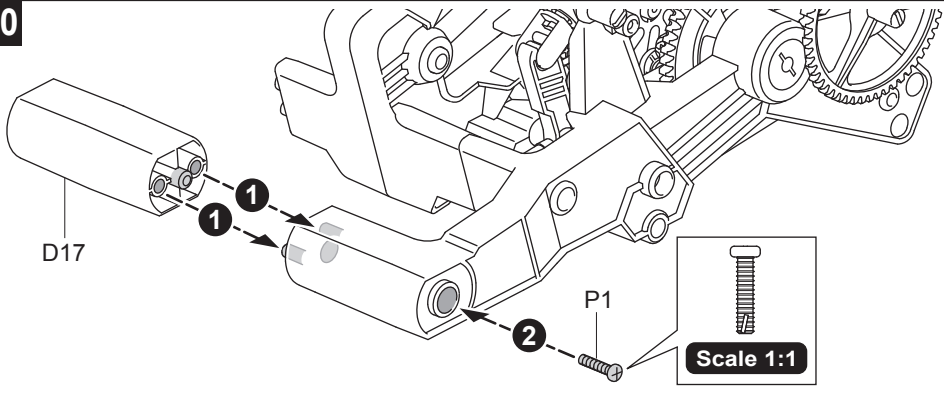

21

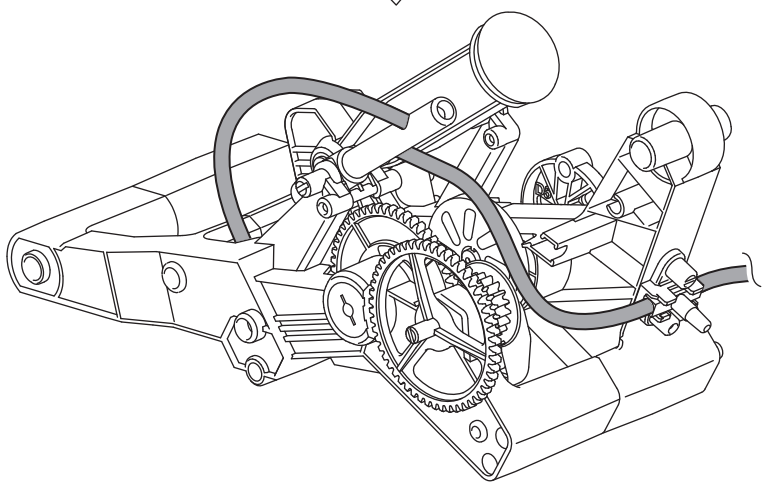
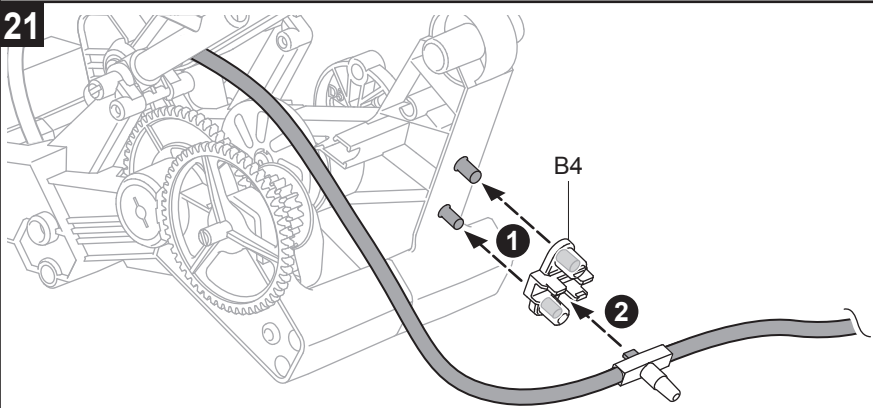

22

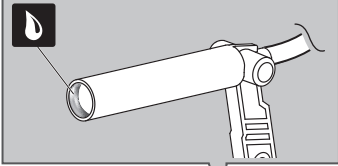

Take off B13 if P10(Red Cap) was twisted during assembly. Re-insert B13 to A2 after P10 was re-set flatly.



B13

P10

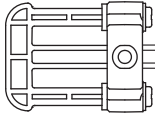

D14

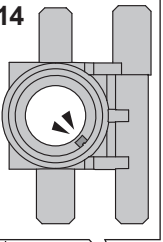

A2



D14

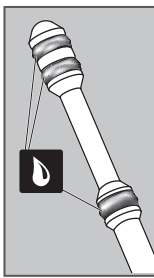

Note: Make sure to lock A2 / D14 entirely.



Do not mix up D9 & D14, make sure to use D14 for assembly.

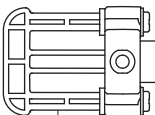

B10

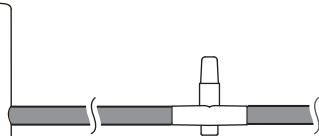

B13



Push & pull the oiled part B10/B13 several times to make them work smoothly.

23

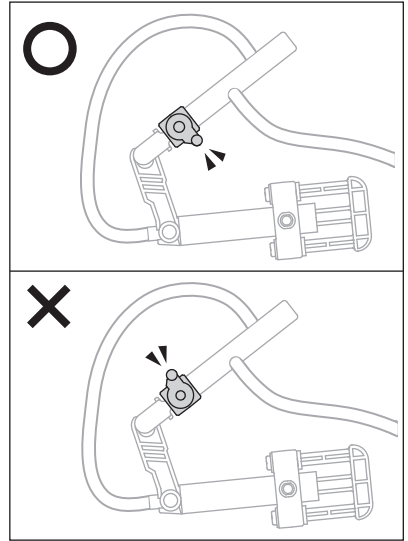
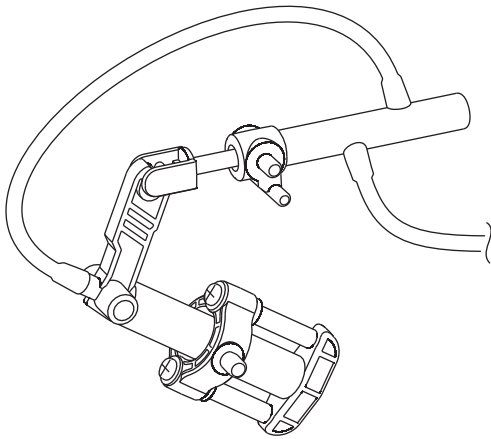
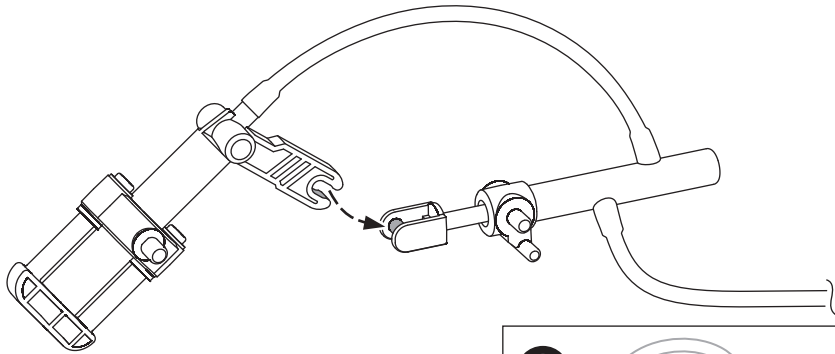

24

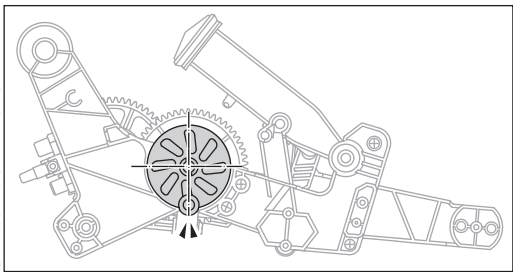
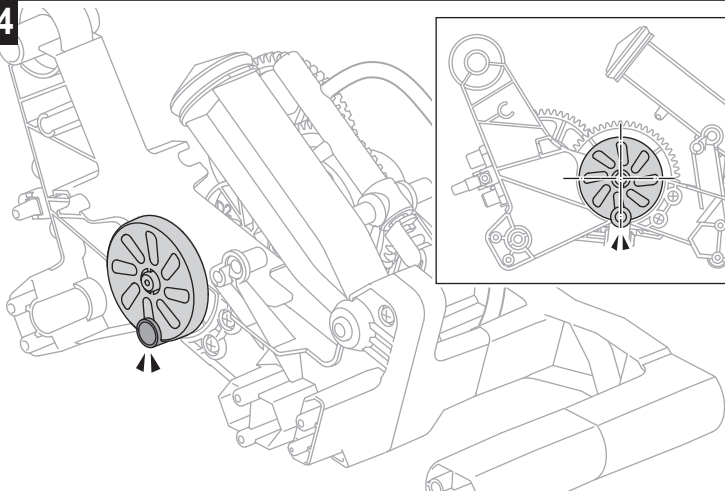

25

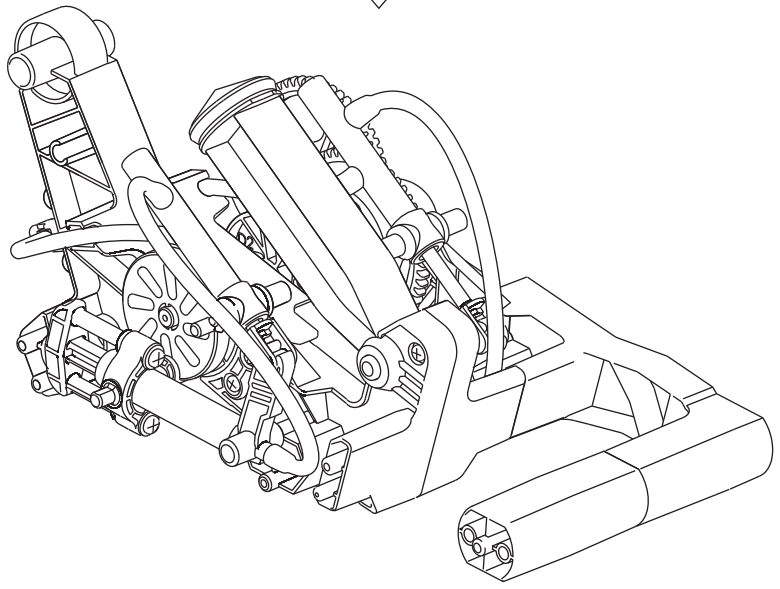
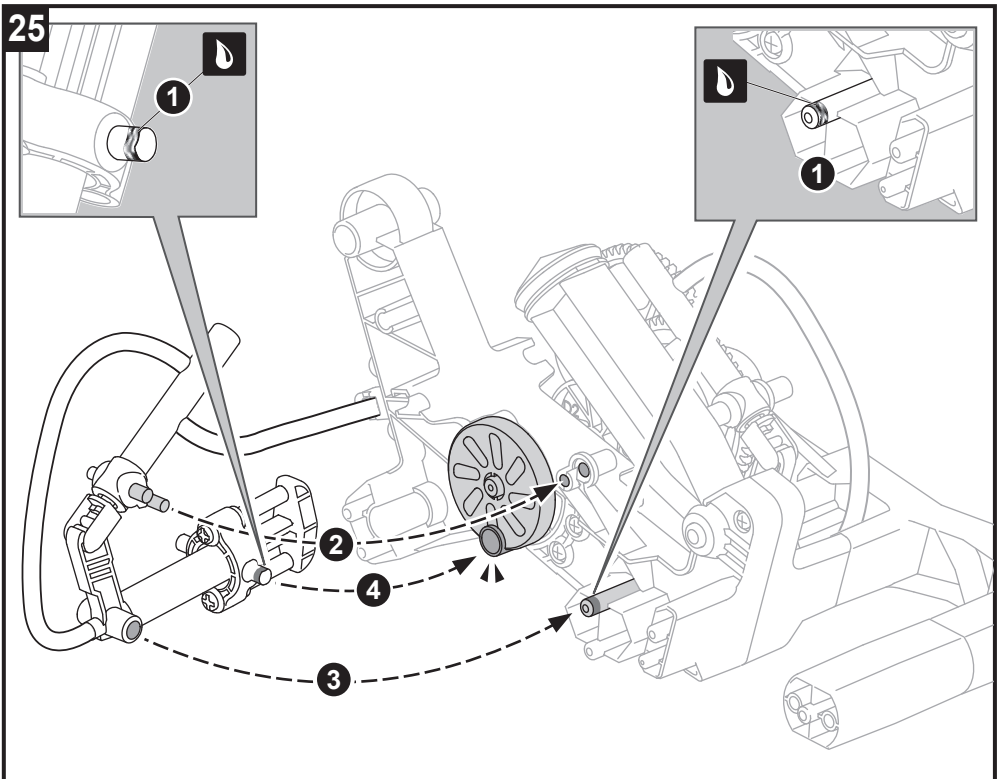

26

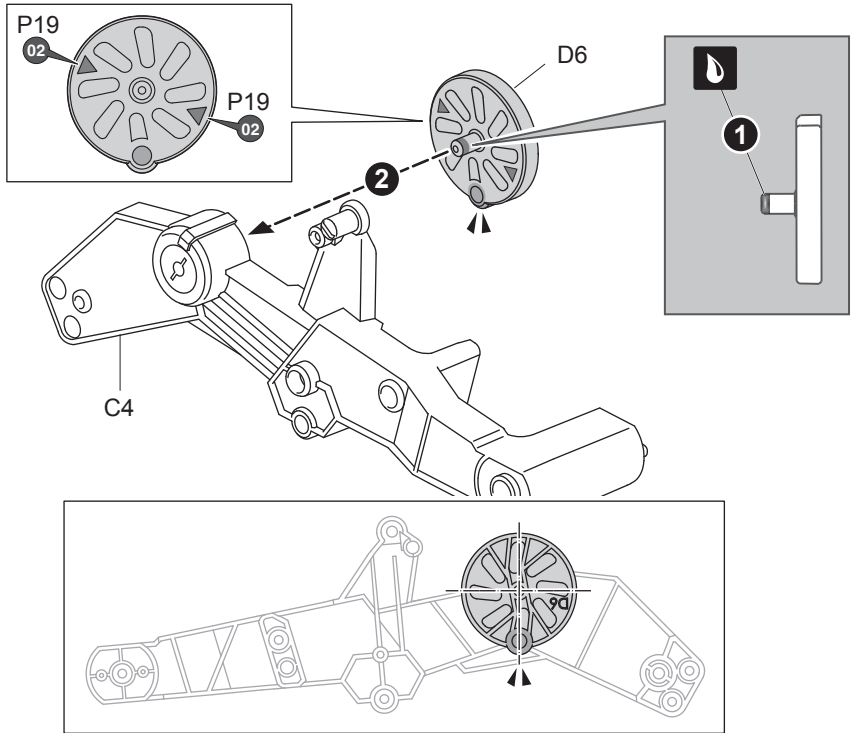

27

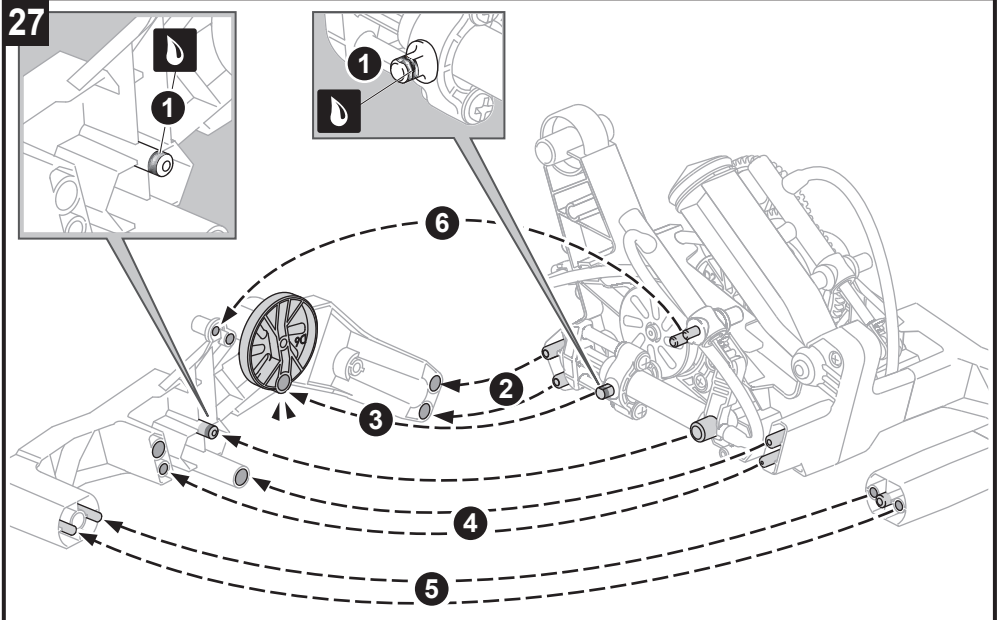

28

P1x5

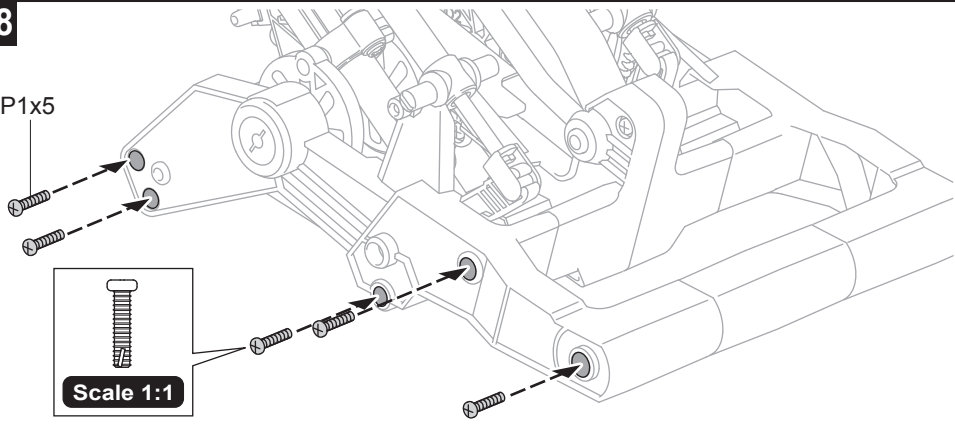

Scale 1:1

29

Top View

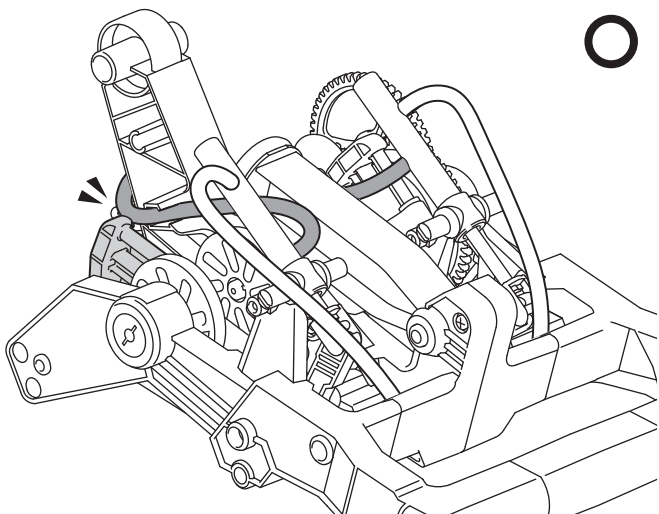
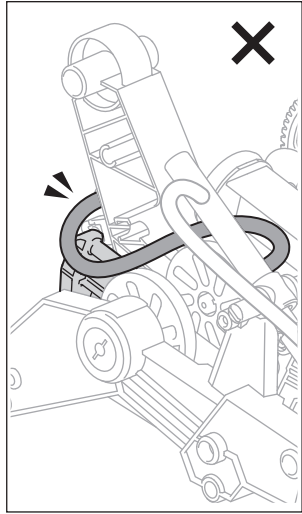
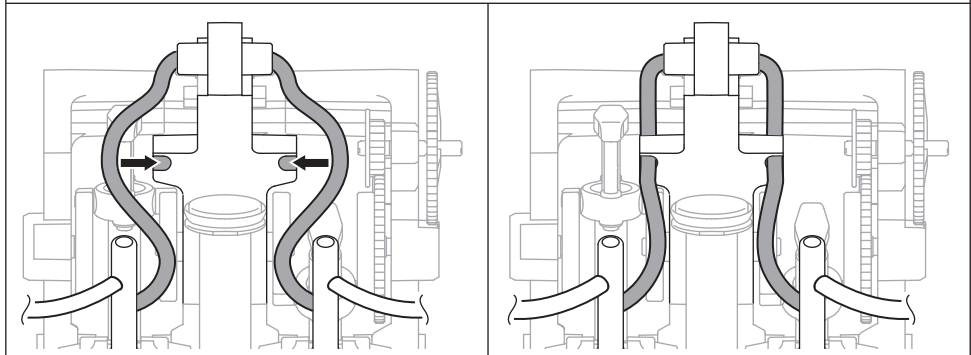

30

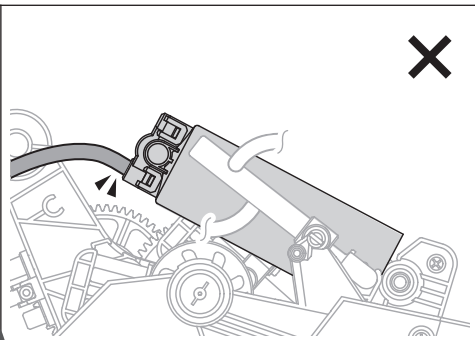
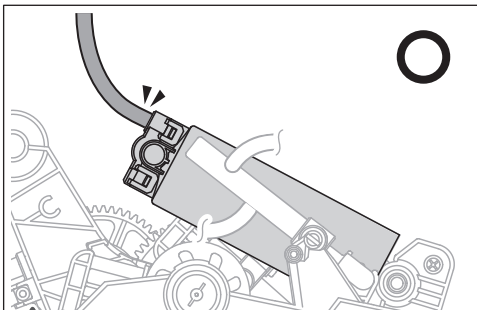
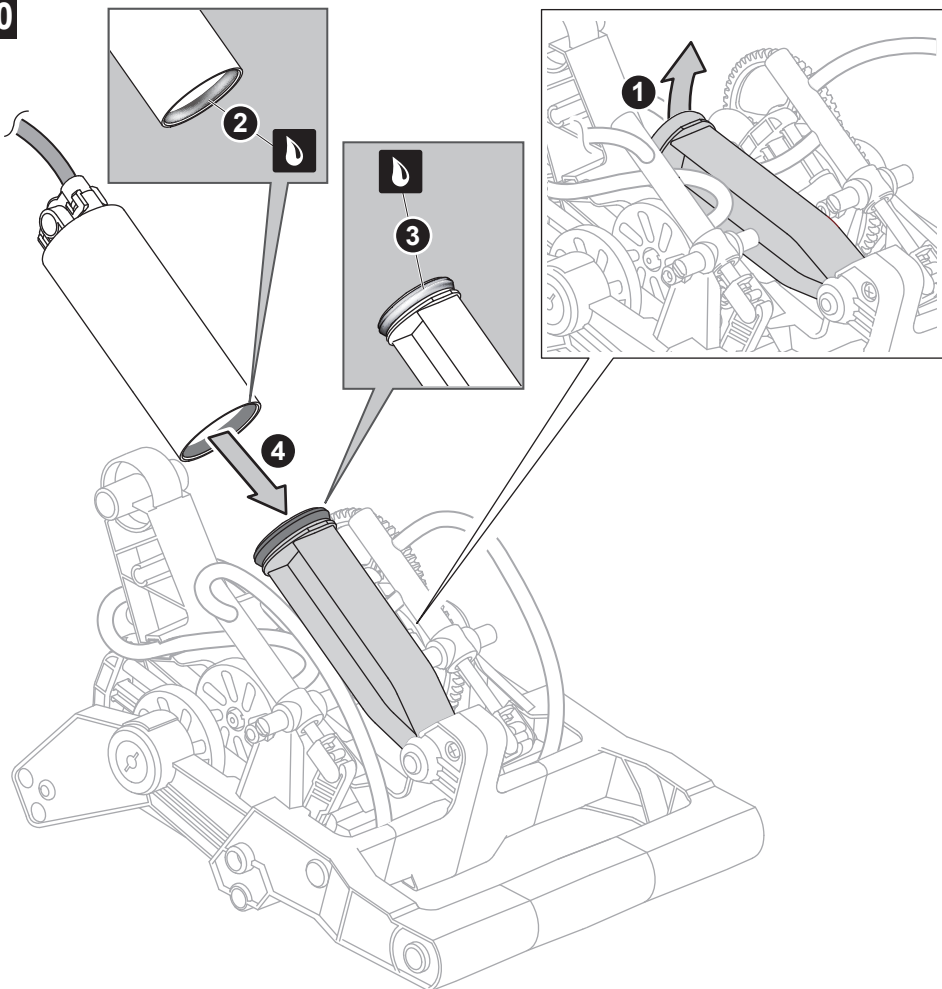

Ensure the right direction of air tube.

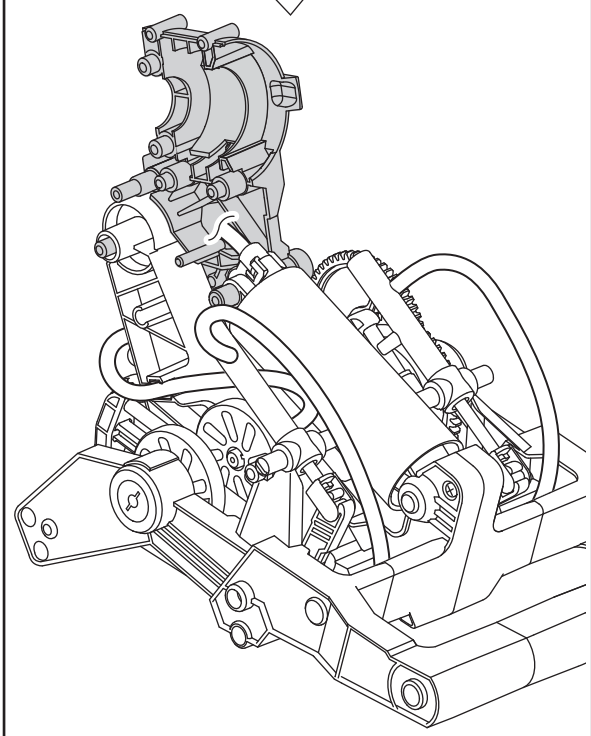
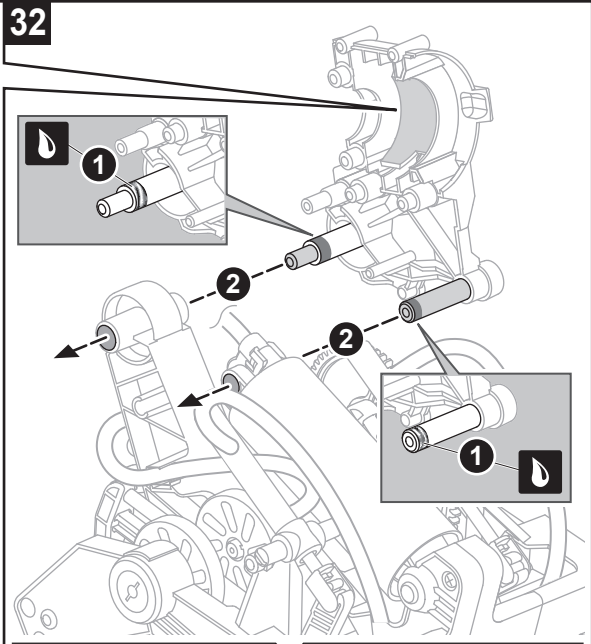
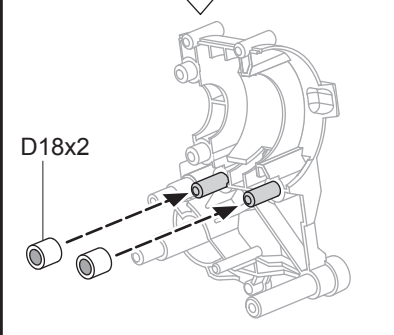
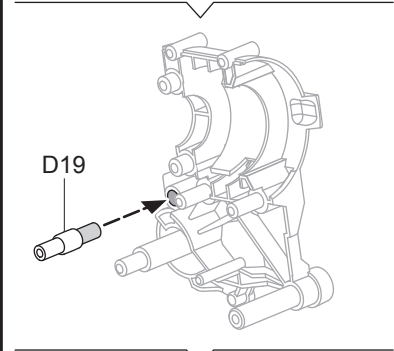
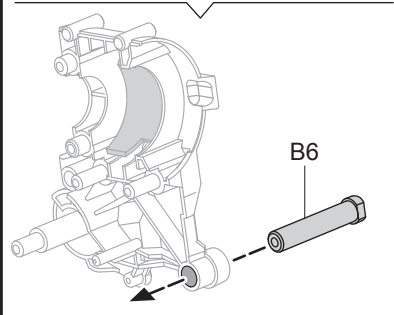
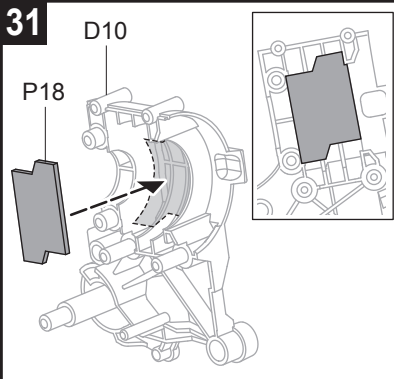

33

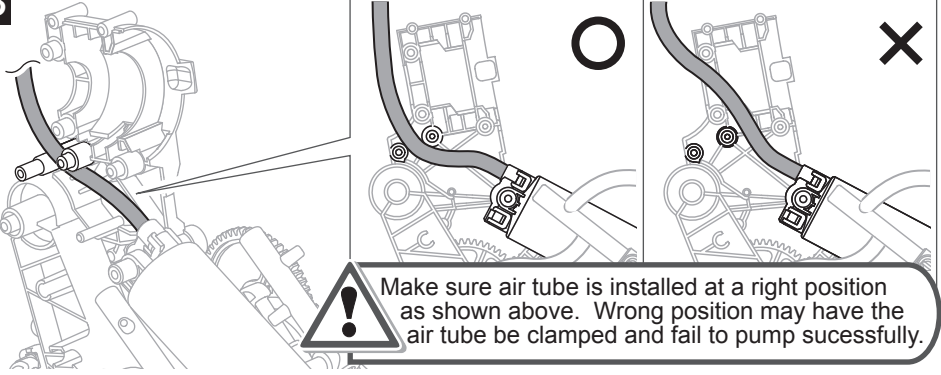

Make sure air tube is installed at a right position as shown above. Wrong position may have the air tube be clamped and fail to pump sucessfully.

34

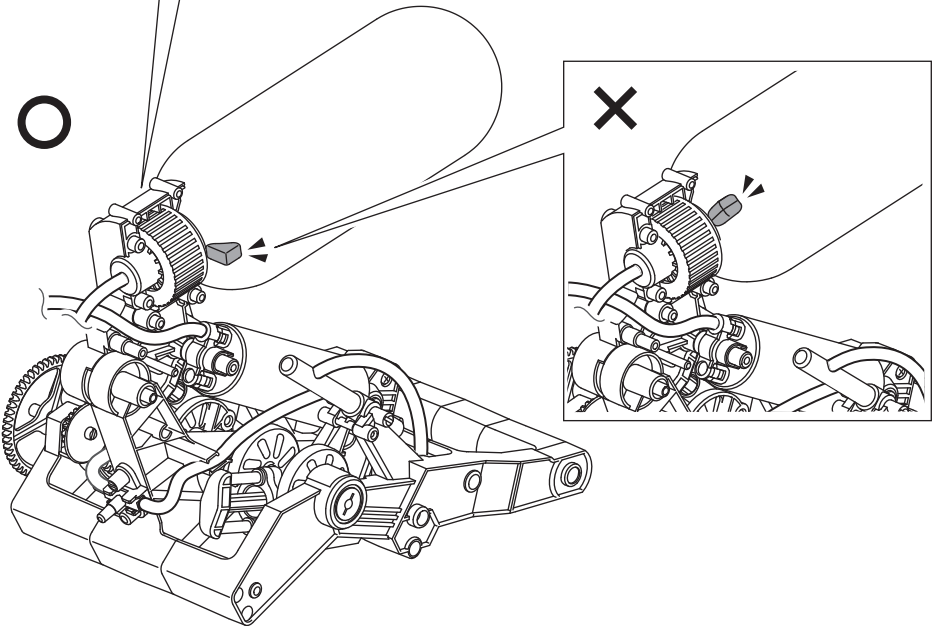
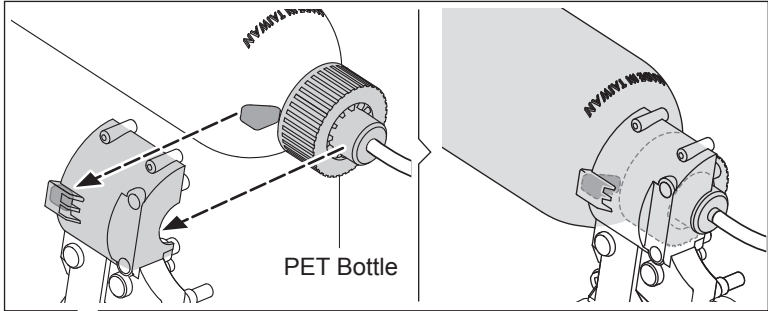

35

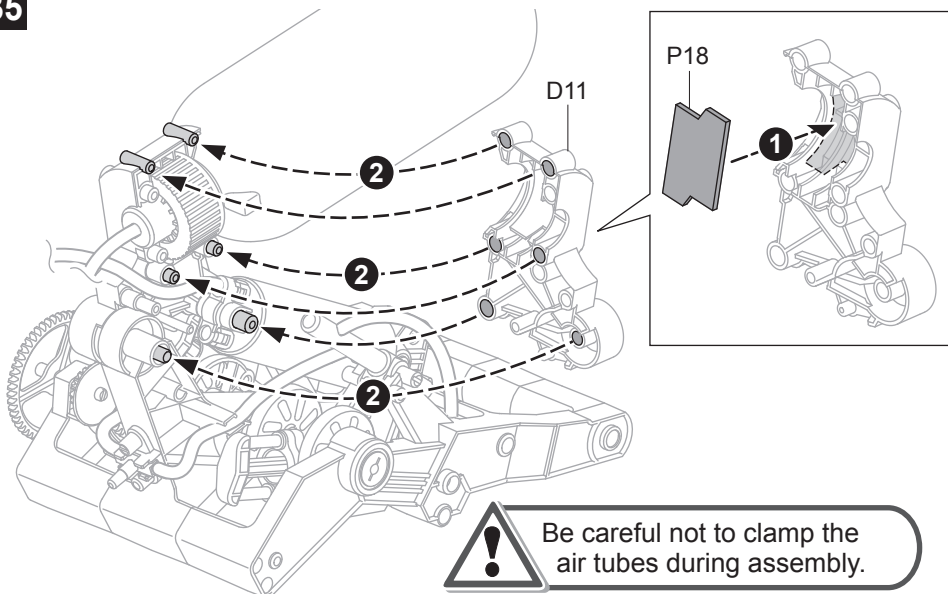

36

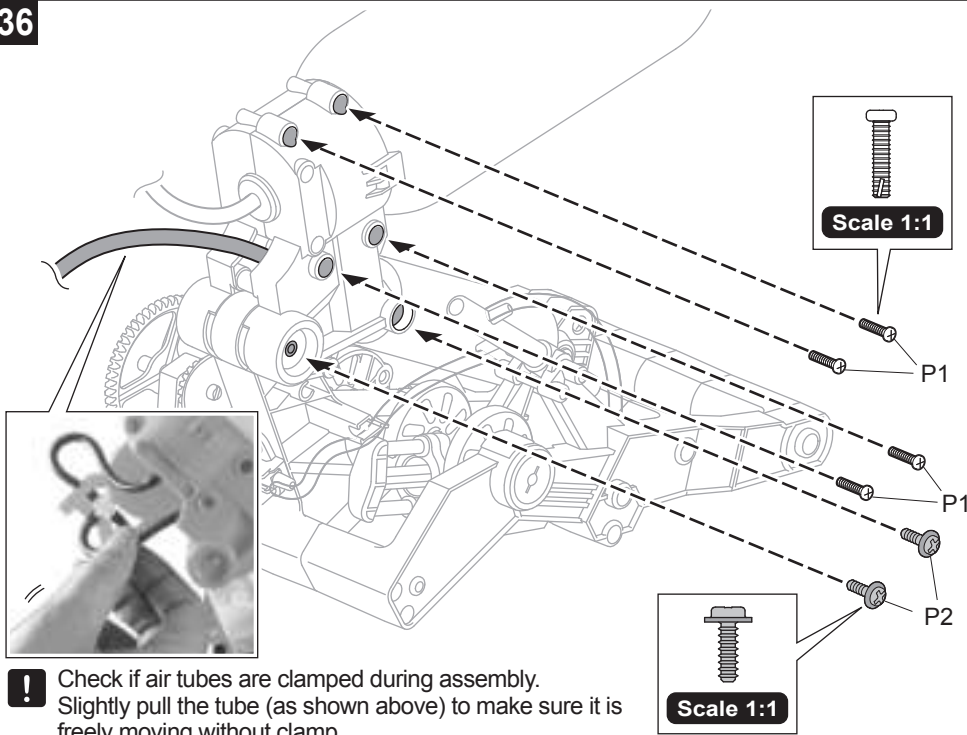

37

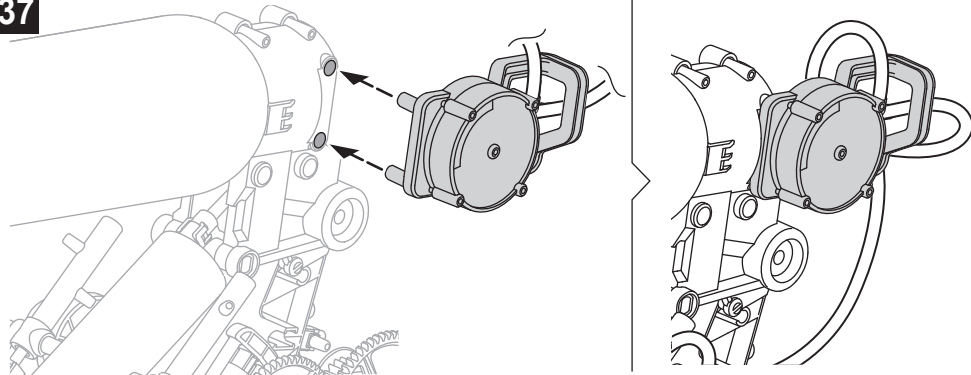

38

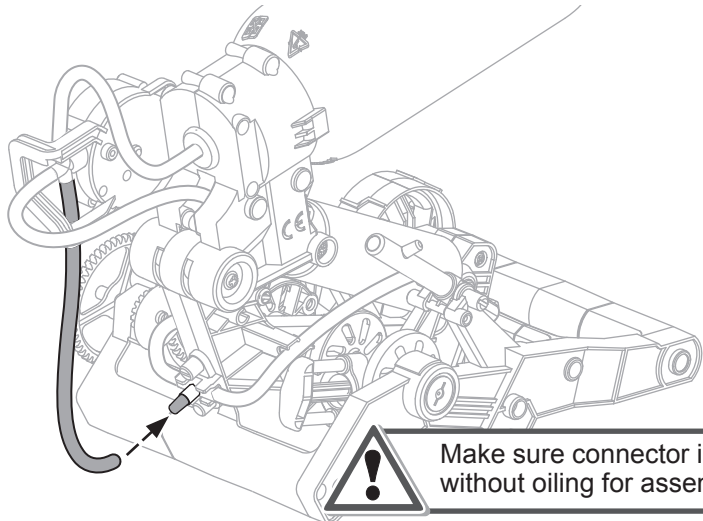

Make sure connector is without oiling for assembly.

39

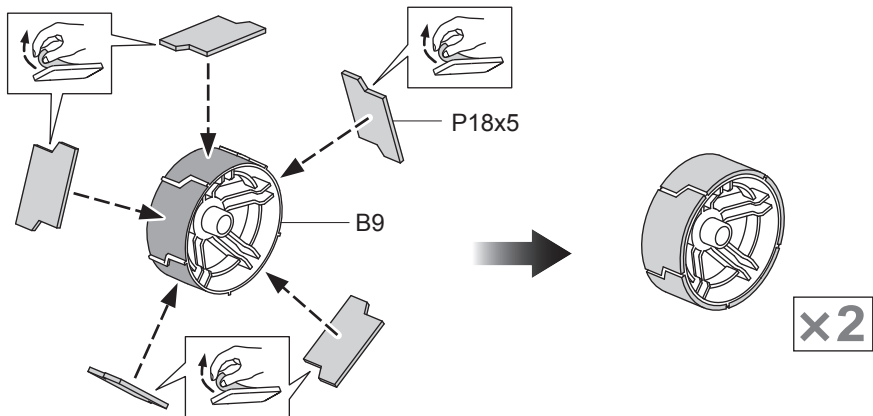

40

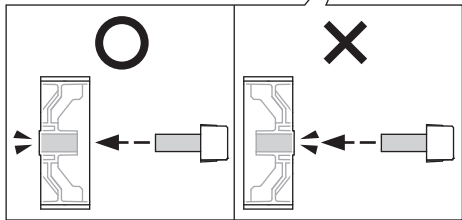
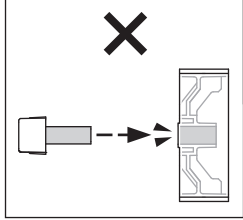
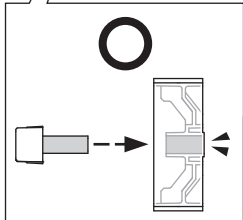
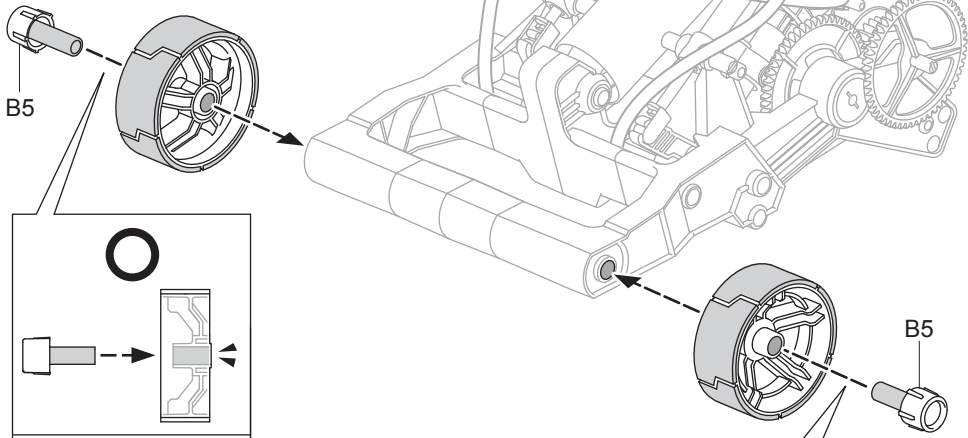

41

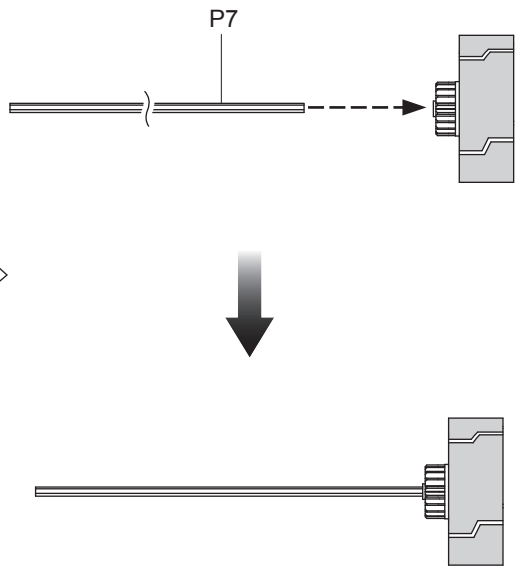
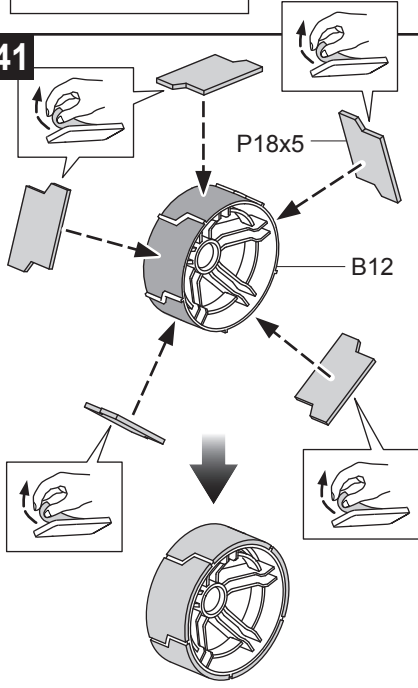

42

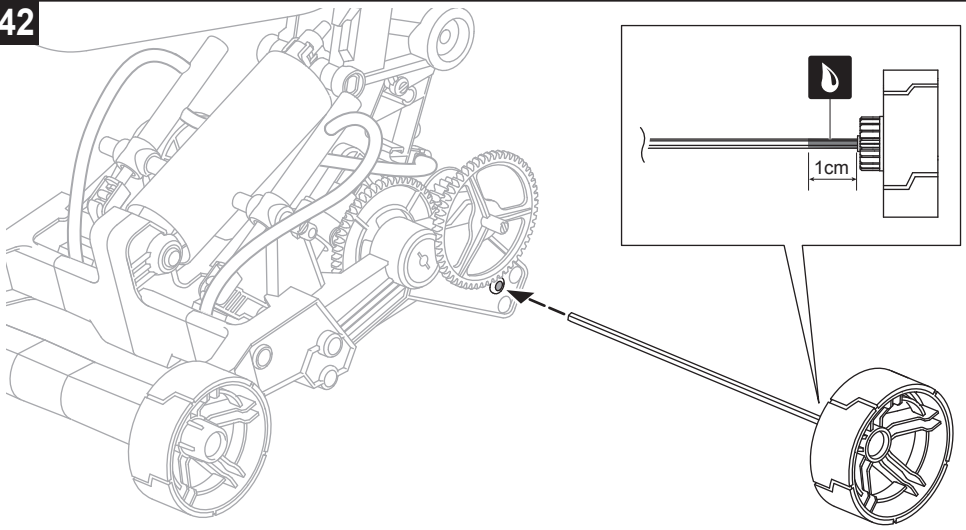

43

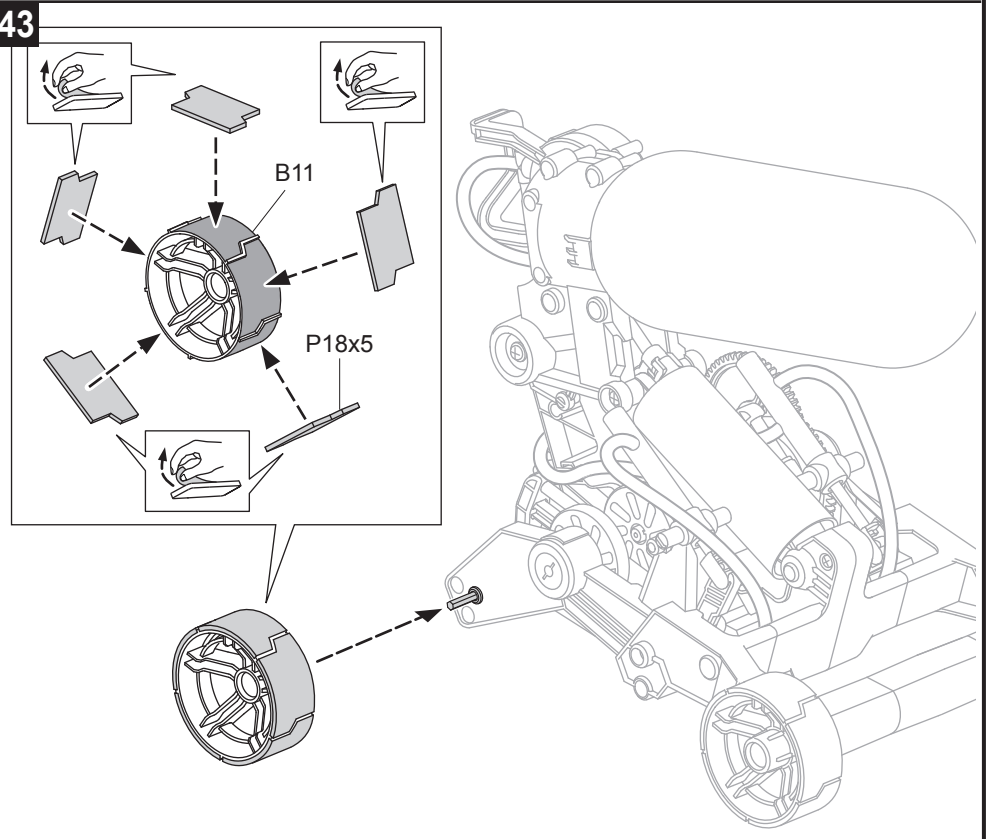

44 Finished

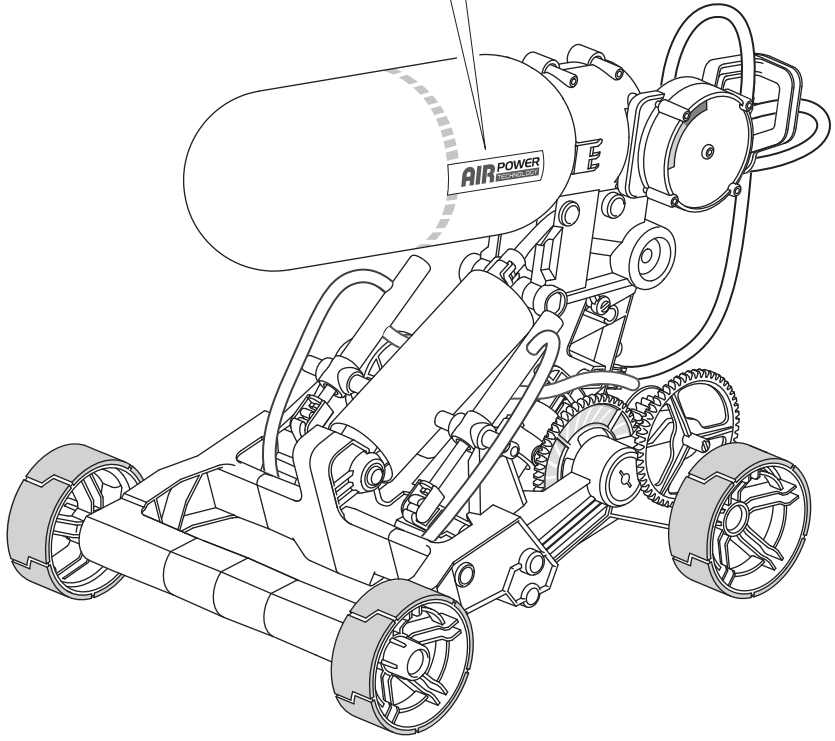
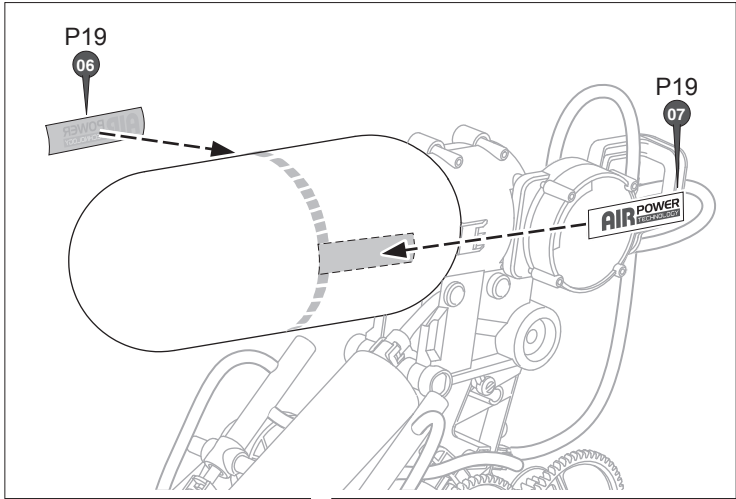

How To Play

1. Spin the rear wheel (as below) to release air completely.

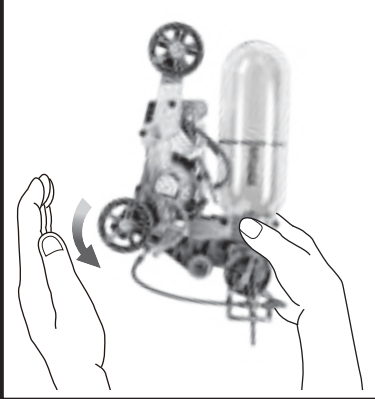

2. Rotate the rear wheel and have the "▼" align to the protrusion bar (as below), then start to pump.

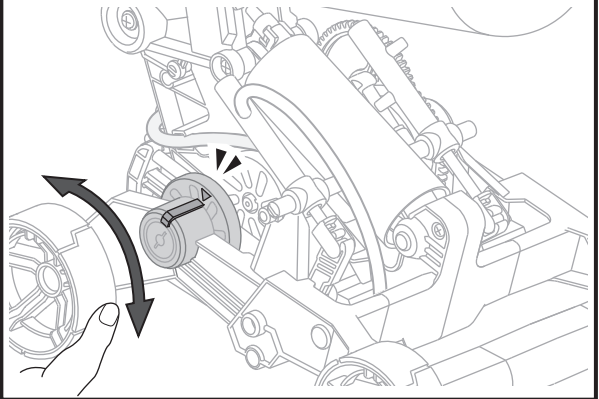

3. Pumping as below figures .

! In the beginning, pump up 20 times at least to start.
(To obtain the best results, do not stop pumping until pressure meter measured and pointed to the red range.)

1

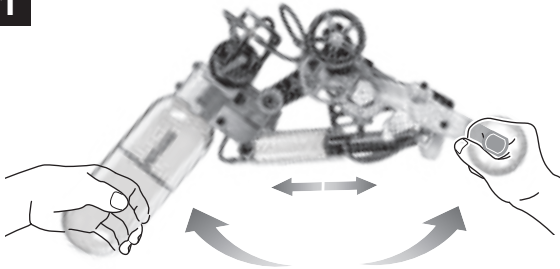

2

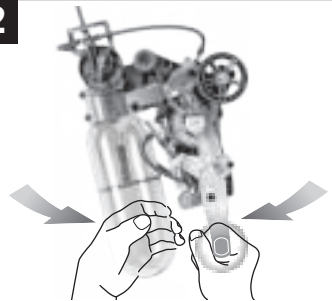

A safety device is equipped, excessive air will be released automatically once pressure meter measured and pointed to the red range.

3

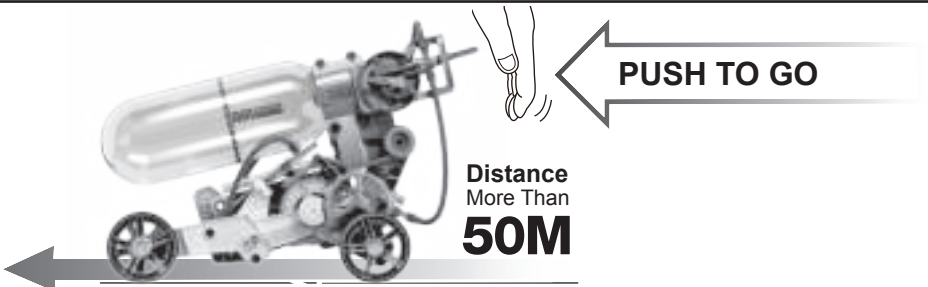

Trouble Shooting

1 If pressure meter can not gauge to red range, or air leaks from uncertain somewhere.

1-1 Check if air tubes are installed correctly. (Below marked positions to help you quick check the air tubes, for exact assembly steps - refer to page 4 “ How To Fit Air Tube ”)

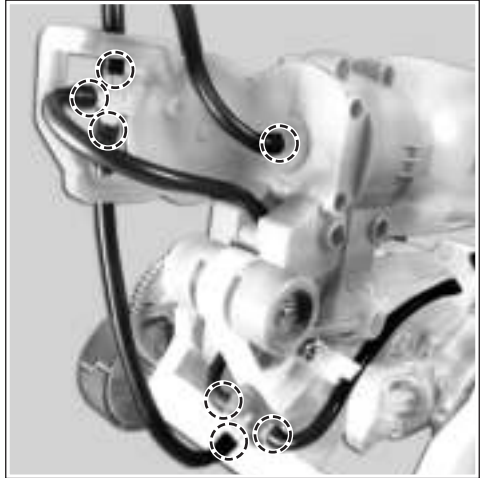
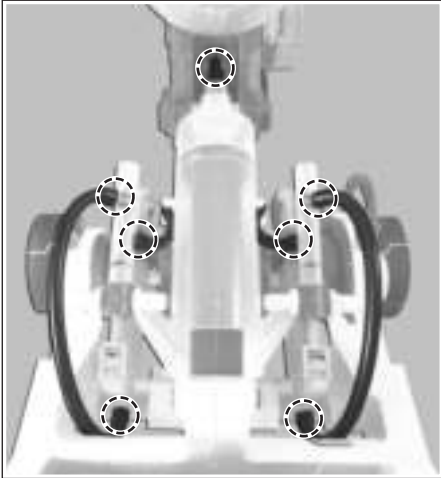

1-2 Check if D9,A2 / D14, A2 are loose..
(refer to page 24, step 15 & page 29, step 22)

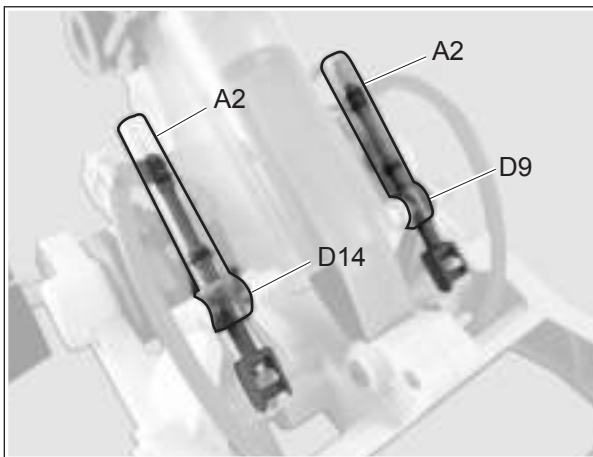

1-3 Check if P10 & D16 are installed correctly. (refer to page 10, step 7)

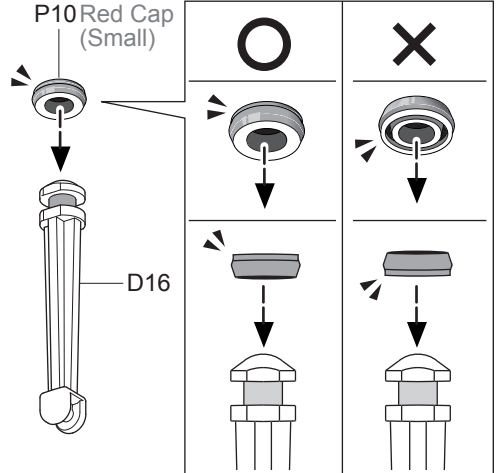
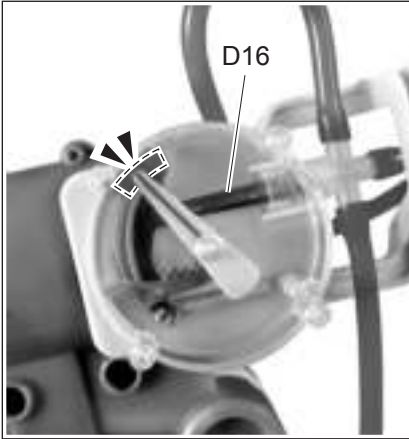

1-4 Check if P14 is fastened tightly. (refer to page 8, step 5)

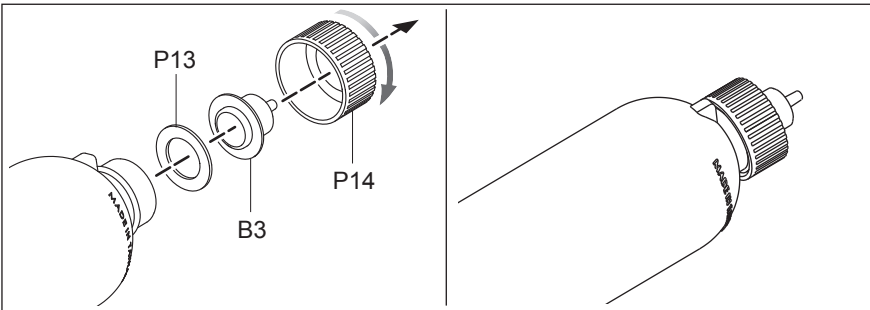

1-5 Check if E2 / A3 are loose. (refer to page 12, step 4)

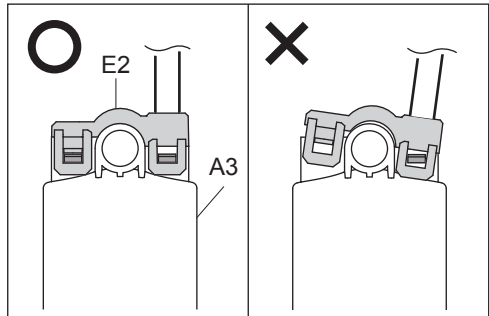
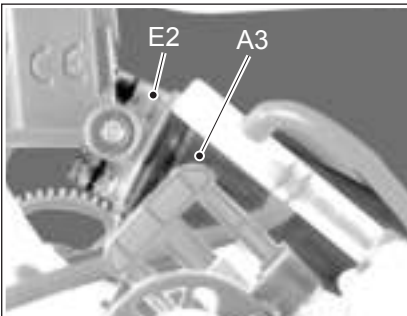

1-6 Check if P9 (O-ring) is set flatly. (refer to page 12, step 6)

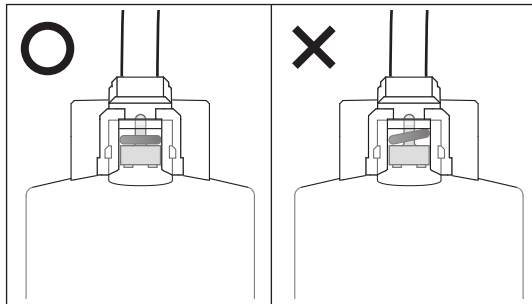
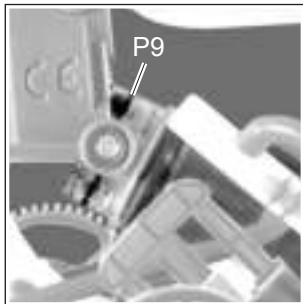

1-7 Check if P17 is installed in the right direction. (refer to page 12, step 3)

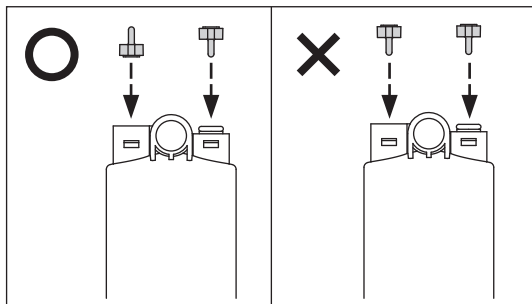
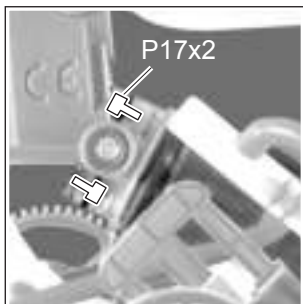

1-8 Check if P10/ B13 are installed in the right direction. (refer to page 22, steps 11~13)

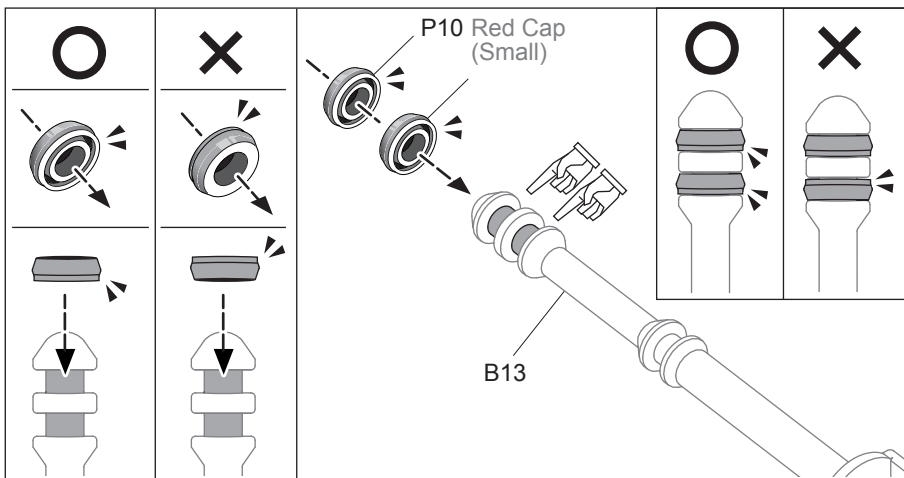

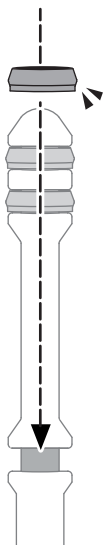
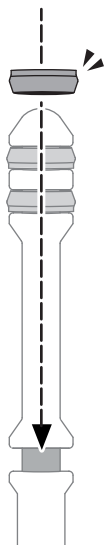
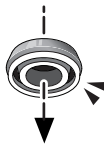

P10
Red Cap
(Small)

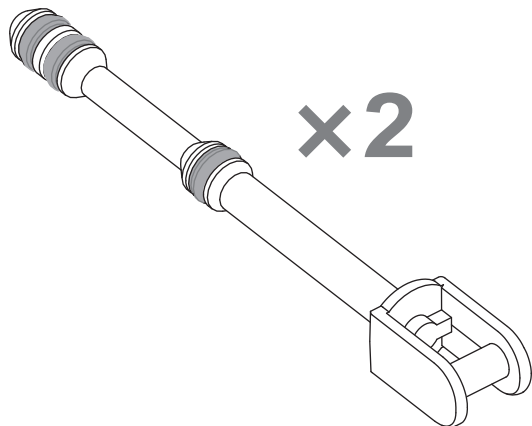
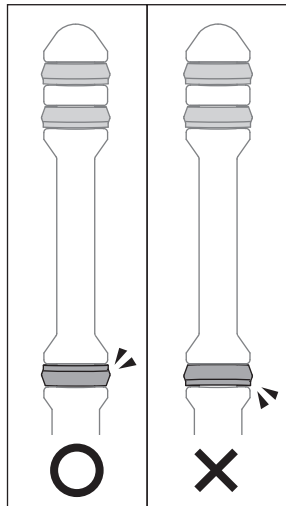
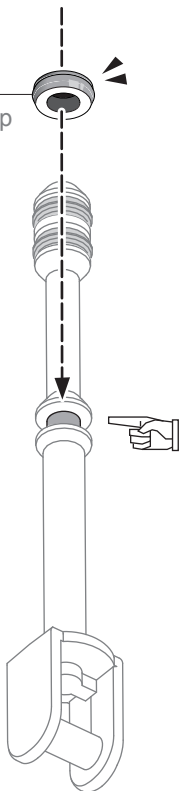

Tip :

Use C5 to make it smooth if P10 was twisted during assembly.

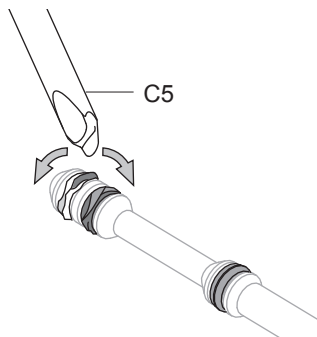

2 If air tubes are loosened while pumping.

2-1 Check if connectors are stained by oil. Take off the connectors/air tubes, make sure to wipe off the oil and use neutral detergent to clean the parts thoroughly.

2-2 Check if air tubes are clamped during assembly. Slightly pull the tube (as shown below) to make sure it is freely moving without clamp.



3 If the pressure meter does not function while pumping.

3-1 Check if pointer is installed correctly (refer to page 11, step 12)

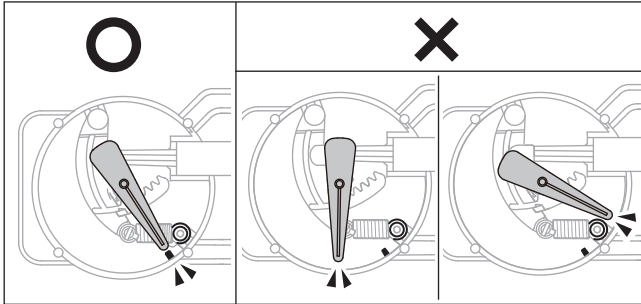

3-2 Check if air tubes are clamped (refer to Trouble Shooting 2-2)

4 Check if D2 / D5 are installed in the right direction. (refer to page17, step 2)

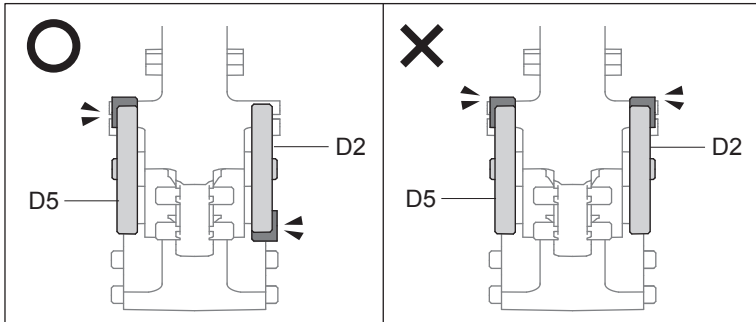

AIR POWER

ENGINE CAR KIT



CE



WARNING :

CHOKING HAZARD

Small parts

Not for children under
3 years



Warning:

For safety concern, always play this car under open and safety environment.
Also, do not attempt to re-create or modify the car design, it might contain potential risk.