

# HONDA



## PA 50



### PARTS LIST

HONDA GENUINE PARTS

2 ED.

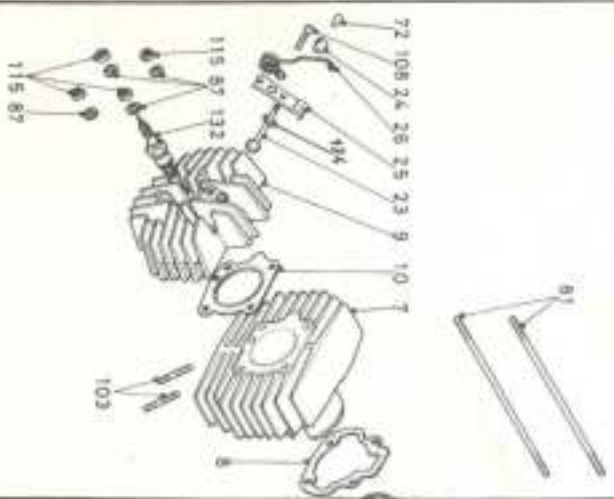
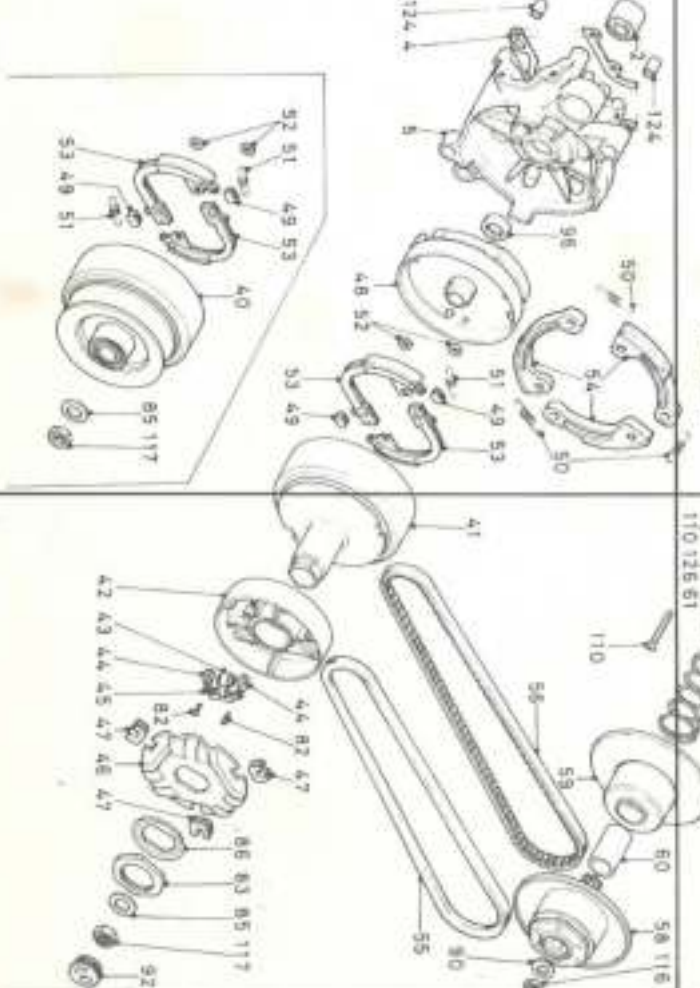
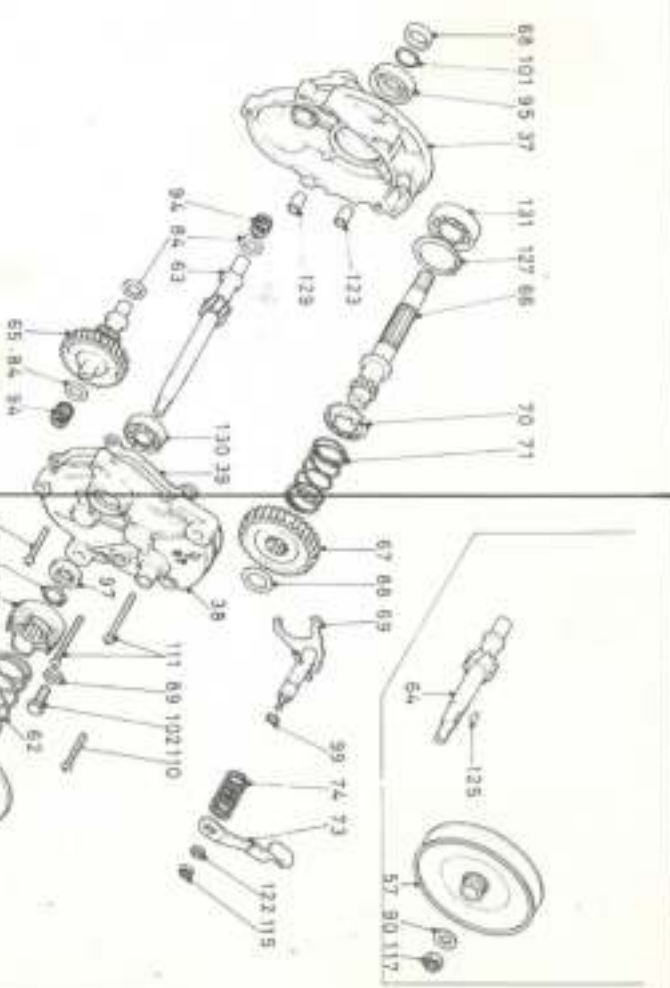
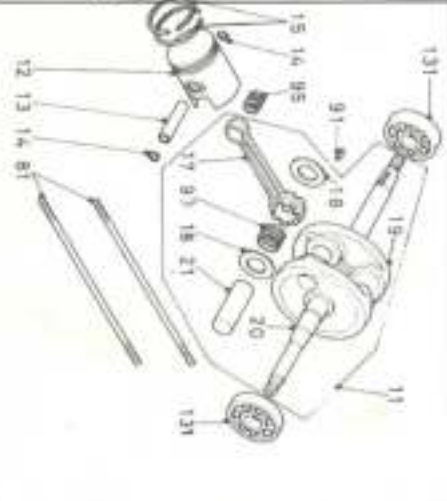
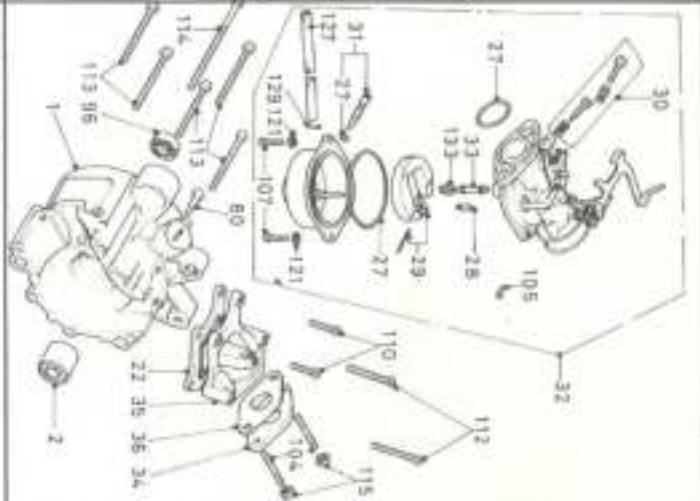
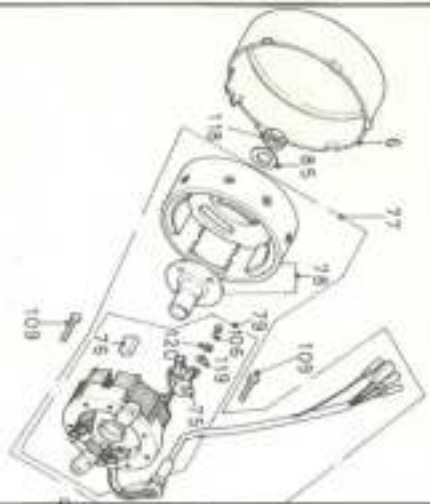

A

B

C

D

2

1

---

**HONDA PA 50**

**PARTS LIST 2<sup>de</sup> Ed.**



77100 - 001 - 010 - A  
Body Work in Progress

### INSTRUCTION FOR USE OF PARTS LIST

#### 1. Make-up of the Part Number

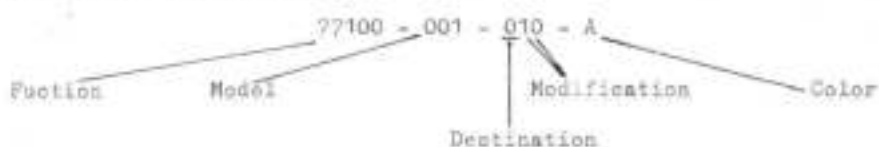

#### 2. Abbreviations

ASSY	Assembly
COMP	Complete
HEX	Hexagonal
22 T.	22 teeth

#### 3. Dimensions

All dimensions are in millimeters except for steel balls, rims and tires.

PARTS	EXAMPLE	INTERPRETATION
Bolt	6 X 12	6 mm. diameter, 12 mm. length
Pin	8 X 14	8 mm. diameter, 14 mm. length
O-ring	9,5 X 1,6	9,5 mm. diameter, 1,6 mm. thickness
Oil seal	14 X 24 X 5	14 mm. inside diameter 24 mm. outside diameter, 5 mm. thickness
Tube	5 X 130	5 mm. inside diameter, 130 mm. length

#### 4. Code

V : Honda V-matic  
 1-5 : One speed  
 UK : Used for England

#### 5. Color code

C SCARLET RED  
 GL LIGHT GREEN  
 MB MEDIO BLUE  
 NO NATIONAL ORANGE  
 YB BRIGHT YELLOW





INSTRUCTIONS ZUM GEBRAUCH DES ERSATZTEILKATALOG

1. Zusammenstellung einer Ersatzteilnummer

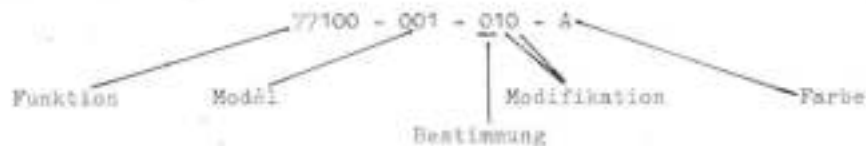

2. Abkürzungen

ASST	Kit
COMP	Vollständig
HEX	Hexagonal
22 T	22 Zähne

3. Abmessungen

Alle Abmessungen sind in Millimeter, ausgenommen stählern Kugeln, Reifen und Felge.

ERSATZTEIL	VORBILD	BESCHREIBUNG
Folzen	6 X 12	6 mm. Durchmesser, 12 mm. Länge
Stift	8 X 14	8 mm. Durchmesser, 14 mm. Länge
O-Ring	9,5 X 1,6	9,5 mm. Durchmesser, 1,6 mm. Dicke
Ol-Dichtung	14 X 24 X 5	14 mm. inner Durchmesser 24 mm. Kussen Durchmesser, 5 mm. Dicke
Bohr	5 X 130	5 mm. inner Durchmesser

4. Code

V : Honda V-matic  
 1-S : Standard  
 EH-MO : (Moped) für Deutschland  
 EH-MA : (Mofa) für Deutschland  
 SH : für Switzerland

5. Farbe code

C SCARLET RED  
 GL LIGHT GREEN  
 ME MEDIO BLUE  
 NO NATIONA ORANGE  
 XD BRIGHT YELLOW

INSTRUCTIES VOOR HET GEBRUIK VAN DE PARTS LIST

1. Samenstelling van een onderdeelnummer



2. Afkortingen

ASSY	Kit (gemonsteerd geheel)
COMP	Volledig
HEX	Hexagonaal
22 T	22 tanden

3. Afmetingen

Alle afmetingen zijn in millimeter, uitgesonderd stalen kogels, banden en velgen.

ONDERDEEL	VOORBEELD	BESCHRIJVING
Bout	6 X 12	6 mm. diameter, 12 mm. lengte
Pin	8 X 14	8 mm. diameter, 14 mm. lengte
O-ring	9,5 X 1,6	9,5 mm. diameter, 1,6 mm. dikte
Oliekeerring	14 X 24 X 5	14 mm. binnen diameter 24 mm. buiten diameter, 5 mm. dikte
Buis	5 X 130	5 mm. binnen diameter, 130 mm. lengte

4. Code

V : Honda V-matic model  
 1-S : Standaard model  
 NL : Gebruikt in Nederland  
 E : Gebruikt in België    B-MA = MOFA = 25 Km/h  
                                   B-NO = MOPED = 40 Km/h

5. Kleur code

C SCARLET RED  
 GL LIGHT GREEN  
 ME MEDIUM BLUE  
 NO NATIONAL ORANGE  
 XB BRIGHT YELLOW



Block N°	Ref. N°	Part N°	Description	Req. Mt	FRT	Remarks
1B	1	11101-147-020	CRANKCASE, right	1	0.5	
1B	2	11102-147-000	BUSH ENG. HANGER, rubber	2		
1B	3	11103-148-300	PISTON, sealing, 22 mm.	1		
2C	4	11191-147-000	GASKET, crankcase	1	0.5	
3C	5	11201-148-000	CRANKCASE, left	1	0.5	PH, UK
		11201-148-610	CRANKCASE, left	1	0.5	EH-MA, B-MA
		11201-148-640	CRANKCASE, left	1	0.5	SH
		11201-148-630	CRANKCASE, left	1	0.5	EH-MO, B-MO
1A	6	11431-147-010	COVER, dynamo	1		
2A	7	12100-148-000	CYLINDER	1	0.2	PH, UK
		12100-148-610	CYLINDER	1	0.2	EH-MA, B-MA
		12100-148-640	CYLINDER	1	0.2	SH
		12100-148-630	CYLINDER	1	0.2	EH-MO, B-MO
2A	8	12191-147-000	GASKET, cylinder	1	0.2	
2A	9	12200-148-000	HEAD COMP. cylinder	1		
2A	10	12251-148-000	GASKET, cylinder head	1		B, PH, UK, EH
		12251-148-640	GASKET, cylinder head	1		SH
2B	11	13000-148-010	CRANKSHAFT COMP.	1	0.6	1-3 PH, UK, B-MO
		13000-148-611	CRANKSHAFT COMP.	1	0.6	1-3 EH-MA, B-MA
		13000-148-701	CRANKSHAFT COMP.	1	0.6	V PH, UK, EH-MO, B-M
		13000-148-711	CRANKSHAFT COMP.	1	0.6	V EH-MA, SH, B-MA
2B	12	13101-148-000	PISTON (STD)	1	0.3	
2B	13	13111-122-000	PIN, piston	1	0.3	
2B	14	13115-147-000	CLIP, piston pin	2	0.3	
2B	15	13011-148-005	RING SET PISTON (TEIKOKU)	1	0.3	
		13011-148-003	RING SET PISTON (NIPPON)	1	0.3	
2B	17	13201-147-300	ROD CONNECTING	1	1.6	
2B	18	13202-122-000	PLATE, connecting rod side	2	1.6	
2B	19	13311-147-300	CRANKSHAFT, right	1	1.6	
2B	20	13321-148-310	CRANKSHAFT, left	1	1.6	1-3 PH, UK, B-MO
		13321-148-611	CRANKSHAFT, left	1	1.6	1-3 EH-MA, B-MA
		13321-148-701	CRANKSHAFT, left	1	1.6	V PH, UK, EH-MO, B-M
		13321-148-711	CRANKSHAFT, left	1	1.6	V EH-MA, SH, B-MA
2B	21	13381-147-300	PIN, crank reed	1	1.6	
1B	22	14100-148-013	VALVE, comp. reed (HOKUSHIN)	1	0.3	PH, UK
		14100-148-014	VALVE, comp. reed (NIPPON)	1	0.3	PH, UK
		14100-148-015	VALVE, comp. reed (ARAI)	1	0.3	PH, UK
		14100-148-691	VALVE, comp. reed (HOKUSHIN)	1	0.3	B, EH
		14100-148-692	VALVE, comp. reed (ARAI)	1	0.3	B, EH

## ENGINE PA 50

Block N°	Ref. N°	Part N°	Description	Qty./M	PRT	Remarks
1B	22	14100-148-693	VALVE, comp. reed (NIPPON)	1	0.3	B, EH
		14100-148-641	VALVE, comp. reed (ROKUSSIN)	1	0.3	SH
		14100-148-642	VALVE, comp. reed (ARAI)	1	0.3	SH
		14100-148-643	VALVE, comp. reed (NIPPON)	1	0.3	SH
2A	23	14911-148-000	VALVE, decomp.	1	0.1	
2A	24	14912-148-000	BRACKET, decomp.	1	0.1	
2A	25	14913-148-000	PLATE, decomp. bolt	1	0.1	
2A	26	14914-148-000	SPRING, decomp.	1	0.1	
1B	27	16010-124-760	PACKING SET	1	0.1	
		16011-143-620	VALVE SET, float	1	0.1	
		16013-124-760	FLOAT SET	1	0.1	
		16016-148-610	SCREW SET	1		
		16024-124-760	SCREW SET, drain	1		
1B	32	16100-148-614	CARBURETOR ASSY.	1	0.2	B, EH
		16100-148-641	CARBURETOR ASSY.	1	0.2	SH
		16100-148-704	CARBURETOR ASSY.	1	0.2	PH, UK
1B	33	16166-148-610	NOZZLE, main	1	0.2	PH, UK; B, EH
		16166-148-740	NOZZLE, main	1	0.2	SH
1B	34	16211-148-000	INSULATOR, carburetor	1	0.2	
1B	35	17111-148-000	PIPE, inlet	1	0.4	B, PH, UK, EH
		17111-148-640	PIPE, inlet	1	0.4	SH
1B	36	17119-148-000	GASKET, inlet pipe	1	0.2	
1C	37	21210-148-000	CASE COMP. MISSION	1	0.2	
1D	38	21300-148-010	COVER, COMP. MISSION	1	0.3	
1D	39	21395-148-000	GASKET, mission cover	1	0.3	
2C	40	22100-148-020	PULLEY COMP., drive (85)	1	0.1	1-S PH, UK, B-MO
		22100-148-612	PULLEY COMP., drive (72)	1	0.1	1-S EH-MA, B-MA
2D	41	22100-148-701	FACE COMP., drive	1	0.1	V PH, UK, EH-MO, B-MO
		22100-148-703	FACE COMP., drive	1	0.1	PH, UK, EH-MO, B-MO V → 1012980
		22100-148-712	FACE COMP., drive	1	0.1	1017489 →
		22100-148-714	FACE COMP., drive	1	0.1	V EH-MA, SH, B-MA Jan'77
2D	42	22110-148-701	FACE COMP., movable drive	1	0.1	V
2D	43	22121-148-700	ROLLER, weight	3	0.2	V PH, UK, EH-MO, B-MO
		22121-148-710	ROLLER, weight	3	0.2	V EH-MA, SH, B-MA
2D	44	22122-148-700	COLLAR, weight	6	0.2	V
2D	45	22125-148-700	PLATE, roller weight	3	0.2	V
2D	46	22131-148-700	PLATE, ramp	1	0.1	V PH, UK, EH-MO, B-MO

Block N°	Ref. N°	Part N°	Description	Req. N°	FRT	Remarks
2D	46	22131-148-710	PLATE, ramp	1	0.1	V EH-MA, SH, B-MA
		22131-148-711	PLATE, ramp	1	0.1	V EH-MA, SH, B-MA Jan
2D	47	22132-148-700	PIECE, slide	3	0.1	V
2C	48	22300-148-010	PLATE ASBY., drive	1	0.3	
2C	49	22356-148-000	DAMPER, starting clutch	2	0.3	→ 1021739
		22356-148-010	DAMPER, starting clutch	2	0.3	1021740 →
2C	50	22401-148-000	SPRING, clutch	3	0.4	
2C	51	22402-148-000	SPRING, starting clutch	2	0.3	
2C	52	22403-148-000	PLATE, clutch set	2	0.2	
2C	53	22520-148-000	WEIGHT, starting clutch	2	0.3	→ 1021739
		22520-148-010	WEIGHT, starting clutch	2	0.3	1021740 →
2C	54	22530-148-000	WEIGHT, clutch	3	0.4	
2D	55	23100-148-003	BELT, drive (MITSUBOSHI)	1		1-S
2D	56	23100-148-702	BELT, drive (MITSUBOSHI)	1		V → 1038049
		23100-148-703	BELT, drive	1		1038050 →
1D	57	23200-148-000	PULLEY COMP. driven (95)	1	0.1	1-S PH, UK, B-MO, EH-MO
		23200-148-610	PULLEY COMP. driven (104)	1	0.1	1-S EH-MA, B-MA, EH-MO
		23200-148-640	PULLEY COMP. driven	1	0.1	1-S SH
2D	58	23210-148-700	FACE COMP., driven	1	0.5	V
2D	59	23220-148-700	FACE COMP., movable driven	1	0.5	V
2D	60	23225-148-700	BUSH, 18 X 22 X 29	1	0.5	V
1D	61	23231-148-700	FOLLOWER, cam	1	0.1	V
1D	62	23233-148-700	SPRING, driven face	1	0.5	V
1C	63	23411-148-000	SHAFT, drive	1	0.1	1-S PH, UK, B-MO
		23411-148-700	SHAFT, drive	1	0.1	V
1D	64	23411-148-610	SHAFT, drive	1	0.1	1-S EH-MA, B-MA
		23411-148-640	SHAFT, drive	1	0.1	1-S SH
1C	65	23420-148-000	COUNTERSHAFT COMP.	1	0.1	
1C	66	23431-148-000	SHAFT, final	1	0.1	
1D	67	23432-148-000	GEAR, final	1	0.1	
1C	68	23433-148-000	COLLAR, final shaft	1	0.1	
1D	69	24210-148-000	SHAFT COMP., shift fork	1	0.1	
1C	70	24221-148-000	SEAT, spring	1	0.1	
1C	71	24222-148-000	SPRING, change	1	0.1	
2A	72	24263-028-000	CLIP	1		
1D	73	24411-148-000	LEVER, shift	1		
1D	74	24412-148-000	SPRING, shift lever	1		
1A	75	30202-122-004	BREAKER COMP., contact	1	0.1	
1A	76	30205-147-000	FELT, oil	1	0.1	

## ENGINE PA 50

Block N°	Ref. N°	Part N°	Description	Req. M4	FRT	Remarks
1A	77	31100-148-612	GENERATOR, flywheel A.C.	1	0.1	B-MO+MA Jan'77 UK, EH, SH, B-MA
		31100-148-613	GENERATOR, flywheel	1	0.1	UK, EH, SH-B-MA B-MO+MA Jan'77
		31100-148-632	GENERATOR, flywheel A.C.	1	0.1	PH, B-MO
		31100-148-633	GENERATOR, flywheel	1	0.1	PH, + B-MO
1A	78	31121-148-611	FLYWHEEL COMP.	1		B-MO+MA Jan'77 UK, EH, SH, B-MA
		31121-148-631	FLYWHEEL COMP.	1		PH, B-MO
1A	79	31141-148-613	STATOR COMP.	1	0.1	B, MO+MA Jan'77 UK, EH, SH, B-MA
		31141-148-633	STATOR COMP.	1	0.1	PH, B-MO
1B	80	90005-147-000	SCREW, special plan 6 X 14	1		
2A	81	90041-147-000	BOLT, stud 6 X 108	4		
2D	82	90101-148-000	SCREW, pan 4 X 4,5	6		V
2D	83	90201-148-700	NUT, special 27 mm.	1		V
1C	84	90412-329-000	WASHER, thrust 10 mm.	3		
1A	85	90426-035-000	WASHER, magneto fixing	2		From 1003550 QTY : 1
		90426-001-000	WASHER, magneto fixing	1		1003551 →
2D	86	90431-148-700	WASHER, lock	1		V
2A	87	90442-035-000	WASHER, sealing 6 mm.	4		
1D	88	90451-703-000	WASHER, thrust 17 mm.	1		
1D	89	90481-001-020	WASHER, 10,2 mm.	1		
2D	90	90485-040-000	WASHER, 8 mm.	1		
2B	91	90741-035-000	KEY, woodruff, 3 X 5	1	0.2	
2D	92	90801-148-700	RUBBER, seal	1		V
2B	93	91001-122-004	BEARING, con-rod big end	1	1.6	
		91001-122-005	BEARING, con-rod big end	1	1.6	
		91001-122-008	BEARING, con-rod big end (TOYO)	1	1.6	
		91002-122-004	BEARING, con-rod big end (KOYO)	1	1.6	
		91002-122-006	BEARING, con-rod big end	1	1.6	
		91002-122-008	BEARING, con-rod big end (TOYO)	1	1.6	
		91003-122-004	BEARING, con-rod big end (KOYO)	1	1.6	
		91003-122-006	BEARING, con-rod big end	1	1.6	
		91003-122-008	BEARING, con-rod big end (TOYO)	1	1.6	
1C	94	91021-148-004	BEARING NEEDLE, 1010 (NTN)	2	0.4	
		91021-148-005	BEARING NEEDLE, 1010 (NIPPON TOMSON)	2	0.4	
		91021-148-006	BEARING NEEDLE, 1010 (NIPPON TOMSON)	2	0.4	
2B	95	91102-122-008	BEARING, con-rod small end (TOYO)	1	0.5	



Block N°	Ref. N°	Part N°	Description	Req. M4	FRT	Remarks
1B	96	91201-147-003	OIL SEAL, 15 X 25.5 X 7	2	0.42	
1D	97	91201-148-003	OIL SEAL, 12 X 22 X 5	1	0.1	
		91201-148-005	OIL SEAL, 12 X 22 X 5	1	0.1	
1C	98	91203-148-003	OIL SEAL, 24 X 34 X 5.5	1	0.1	
		91203-148-005	OIL SEAL, 24 X 34 X 5.5	1	0.1	
1D	99	91301-027-000	O-RING, 6.8 X 1.9	1		
1B	100	91301-147-003	O-RING, 18.5 X 2.2	1		
1C	101	91305-329-000	O-RING, 16 X 1.9	1	0.1	
1D	102	92000-10012-0A	BOLT, hex, 10 X 12	1		
2A	103	92700-06028	BOLT, stud, 6 X 28	2		
1B	104	92700-06032	BOLT, stud, 6 X 32	2		
1B	105	93500-04008-0II	SCREW, pan, 4 X 8	1		
1A	106	93500-04012-0A	SCREW, pan, 4 X 12	1		
1B	107	93500-04012-0II	SCREW, pan, 4 X 12	2		
2A	108	93500-06016-0A	SCREW, pan, 6 X 16	1		
1A	109	93500-06020	SCREW, pan, 6 X 20	2		
1B	110	93500-06025	SCREW, pan, 6 X 25	5		
1D	111	93500-06035	SCREW, pan, 6 X 35	2		
1B	112	93500-06040	SCREW, pan, 6 X 40	2		
1B	113	93500-06045	SCREW, pan, 6 X 45	5		
1B	114	93500-06080	SCREW, pan, 6 X 80	1		
2A	115	94001-06000	NUT HEX, 6 mm.	7		
2D	116	94001-08000-0S	NUT HEX, 8 mm.	1		
2C	117	94001-10000-0S	NUT HEX, 10 mm.	1		
1A	118	94031-10000	NUT HEX, 10 mm.	1		
1A	119	94101-04200	WASHER, plain 4 mm.	1		
1A	120	94111-04000	WASHER, spring 4 mm.	1		
1B	121	94111-04800	WASHER, spring 4 mm.	2		
1D	122	94111-06000	WASHER, spring 6 mm.	1		
1C	123	94301-10160	PIN DOWEL, 10 X 16	2	0.1	
2C	124	94301-10200	PIN DOWEL, 10 X 20	2	0.4	
1D	125	94401-16120	KEY, woodruff, 16 X 12	1		1-G EH-MA, B-MA
1D	126	94510-17150	CIRCLIP, external 17 mm.	1		V
1C	127	94520-40000	CIRCLIP, internal 40 mm.	1	0.1	
1B	128	95001-55300-40	TUBE, fuel 3,5 X 300	1	0.1	
1B	129	95002-02070	CLIP, tube 57	1	0.1	

Block N°	Ref. N°	Part N°	Description	Req. Mt	FRT	Remarks
1C	130	96100-62010	BEARING, radial ball 6201	1	0.1	
2B	131	96100-62035	BEARING, radial ball 6203	3	0.1	
2A	132	98076-55711	PLUG, SPARK (BP5HS - NGK)	1		option
		98076-55721	PLUG, SPARK (W16PP - ND)	1		option
		98076-56719	PLUG, SPARK (BP6HS - NGK)	1		
		98076-56721	PLUG, SPARK (W20PP - ND)	1		
1B	133	99101-124-0720	JET MAIN ( 72)	1	0.2	SH
		99101-124-0750	JET MAIN ( 75)	1	0.2	SH, H
		99101-124-0780	JET MAIN ( 78)	1	0.2	
1A	134	91301-122-300	O-RING 1,4 X 3,6	1		





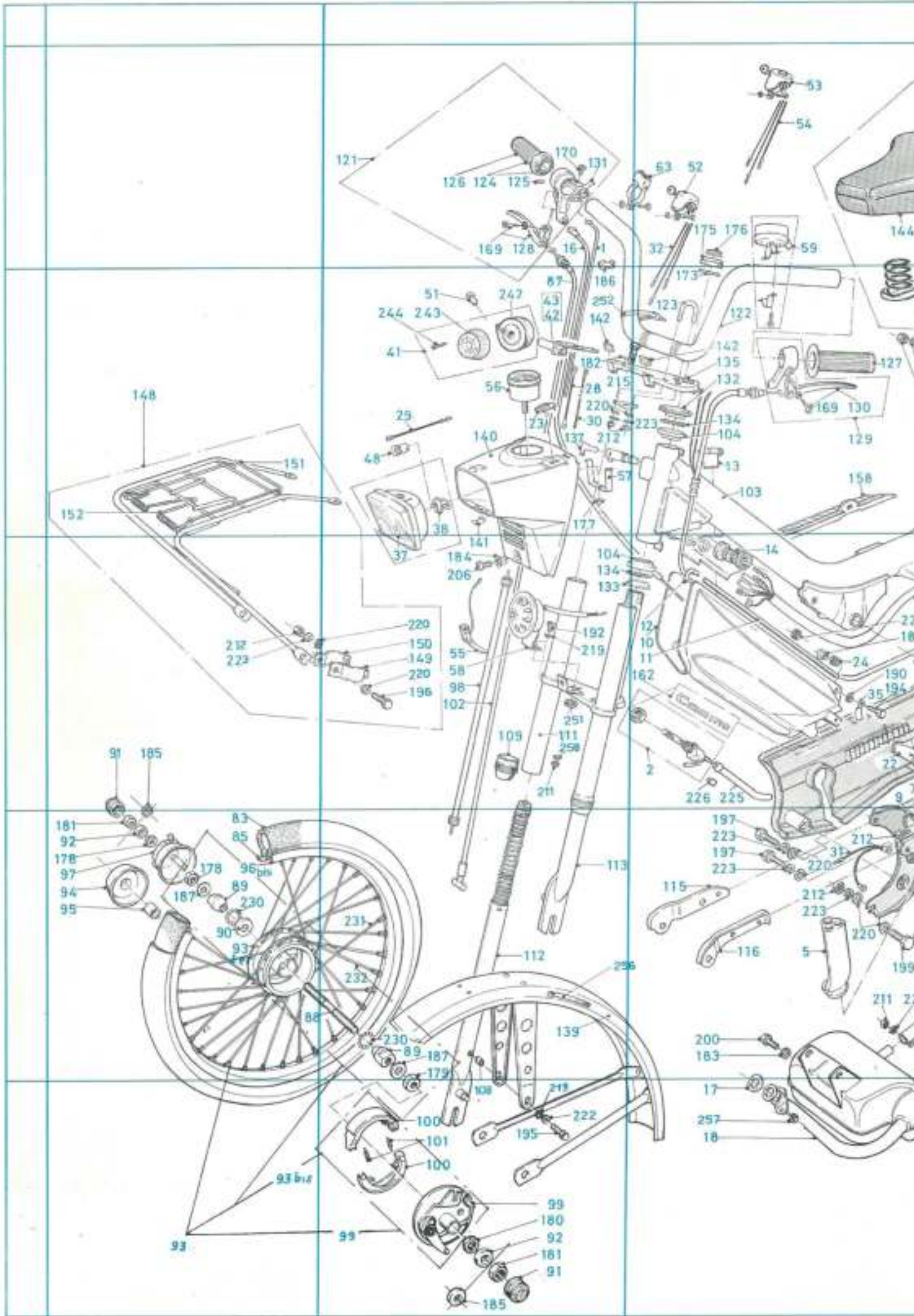

A

B

C



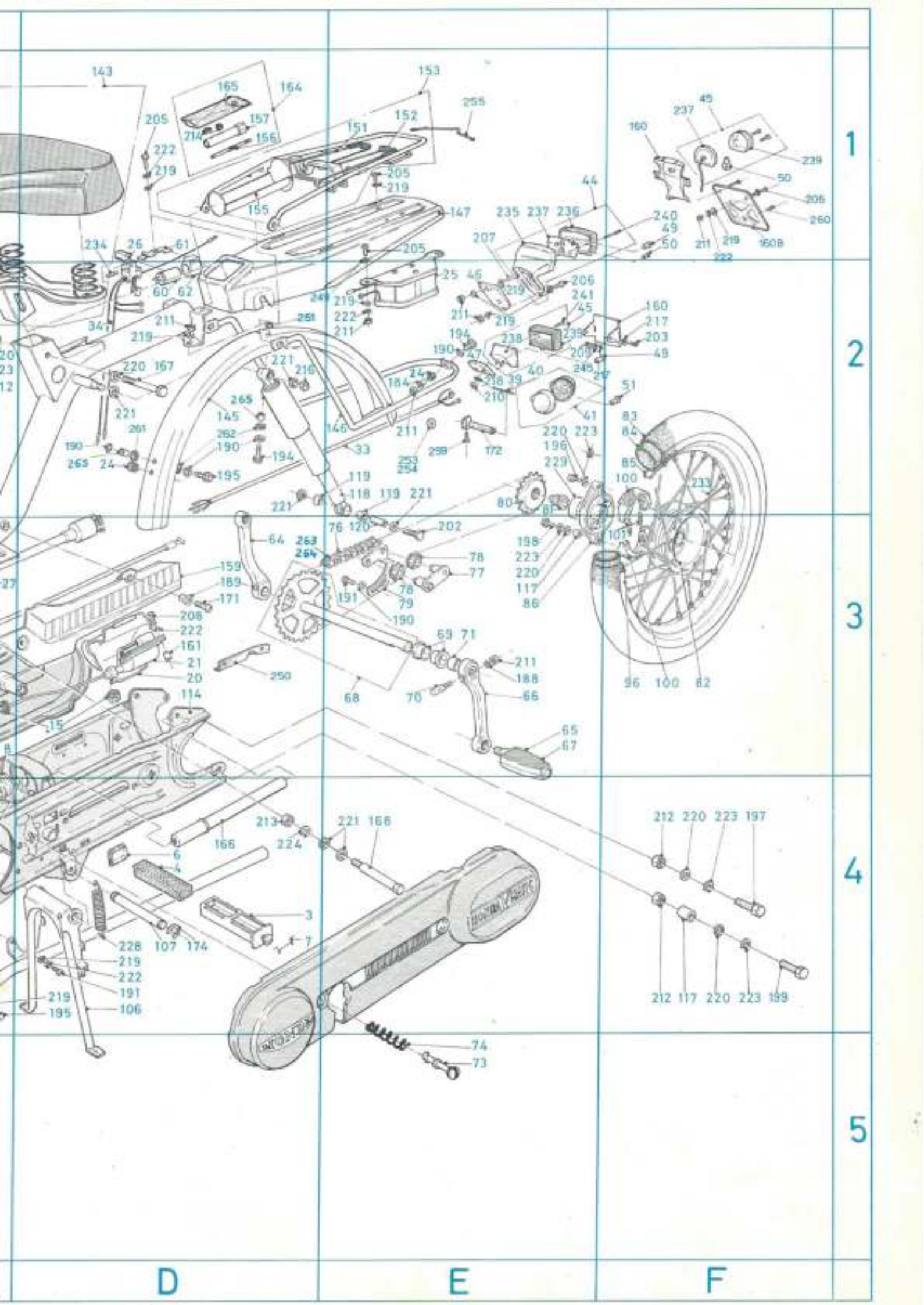

Block N°	Ref. N°	Part N°	Description	Req. N°	PRT	Remarks
B1	1	14950-148-010	CABLE COMP. DECOMP.	1	0.2	
C5	2	10950-148-000	COCK ASSY., fuel	1	0.3	
D4	3	17204-148-000	CASE, A/C element	1		
D4	4	17205-148-000	ELEMENT A/C	1		
C4	5	17211-148-000	TUBE, A/C inlet	1	0.6	
		17211-148-641	TUBE, A/C inlet	1	0.6	SH, EH-MA, B-MA
D4	6	17212-148-000	PKG. ELEMENT A/C	1		
D4	7	17213-148-000	SFO. A/C set	1		
C5	8	17222-148-000	TUBE A/C connecting	1	0.3	
C4	9	17258-122-000	BAND A/C, connecting B	1	0.3	
C5	10	17500-148-000	TANK COMP. fuel	1	0.2	
C5	11	17501-148-720	LACE, fuel tank	2	0.3	
C5	12	17502-148-720	CLIP, tank lace	2	0.3	
C2	13	17620-148-000	CAP, fuel filler short	1		EH-MA, B-MA
		17620-148-600	CAP, fuel filler long	1		B-MO, UK, PH, SH, EH-MO
C5	14	17625-148-000	RUBBER, tank setting	1	0.2	
D3	15	17656-579-010	GROMMET, fuel pump	2	0.2	
B1	16	17910-148-010	CABLE COMP., throttle	1	0.3	
C5	17	18291-148-630	GASKET, exhaust pipe	1	0.3	B, EH-MO
		18291-122-000	GASKET, exhaust pipe	1	0.3	EH-MA, B-MA
C5	17	18291-148-640	GASKET, exhaust pipe	1	0.3	SH
		18291-131-000	GASKET, exhaust pipe	1	0.3	PH, UK
C5	18	18300-148-000	MUFFLER ASSY.	1	0.3	EH-MA, B-MA
		18300-148-620	MUFFLER ASSY.	1	0.3	UK, PH
		18300-148-640	MUFFLER ASSY.	1	0.3	SH
		18300-148-690	MUFFLER ASSY.	1	0.3	EH-MO, B-MO
D4	19	18311-148-640	PIPE, tail	1		SH
D3	20	30510-148-010	COVER, ignition coil	1		
D3	21	30530-148-003	COIL COMP. ignition	1	0.1	
C5	22	30700-148-004	CAP, assy noise suppressor	1		
B2	23	30701-148-000	SWITCH, assy. (SOUBITEZ)	1	0.2	
E2	24	31403-285-000	RUBBER, regulation cushion	2	0.6	Fuel tank→2 Rear fender→2
D2						
C5						
E2	25	31500-148-000	BATTERY, assy.	1	0.2	
D1	26	31700-124-003	RECTIFIER ASSY., silicon	1	0.1	

Block #	Ref. #	Part #	Description	Rec'd	FRT	Remarks
C3	27	32100-148-010	WIRE HARNESS A.			→ 1007975
		32100-148-020	WIRE HARNESS A.		0.2	1007976 →
		32100-148-030	WIRE HARNESS (with stoplamp)	1	0.1	ONE PART
		32100-148-602	WIRE HARNESS (without stoplamp)	1	0.1	ONE PART
		32100-148-801	WIRE HARNESS	1	0.1	OK
B2	28	32103-148-010	SUB CORD, lighting SW B	1	0.1	B, FH, SH, EH
B2	29	32104-148-010	SUB CORD, headlight	1	0.1	B, FH, SH, EH
B2	30	32105-148-610	SUB CORD, lighting SW C	1	0.1	OK
C4	31	32108-148-631	EARTH CORD	1	0.1	
C1	32	32109-148-010	SUB CORD, winker SW	1	0.1	
B2	33	32110-148-010	WIRE HARNESS B (with stop lamp)	1	0.2	0/1007975
		32110-148-020	WIRE HARNESS B	1	0.2	1007976 →
		32110-148-600	WIRE HARNESS B (without stop lamp)	1	0.2	0/1007975
		32110-148-610	WIRE HARNESS B	1	0.2	1007976 →
		32110-148-800	WIRE HARNESS B	1		OK
B2	34	32111-148-010	SUB CORD, battery	1	0.1	
C3	35	32172-319-000	CLIP WIRE, harness	1	0.3	
B3	37	33101-148-600	UNIT, head light	1		OK B-MO - Jan '77 B-MA - 1006568 →
		33101-148-610	UNIT, head light	1		EH, SH
		33101-148-620	UNIT, head light	1		FH
B2	38	33106-148-600	SOCKET			OK B-MO - Jan '77 B-MA - 1006568 →
		33106-148-620	SOCKET			F
B2	39	33405-148-010	SUB CORD, RH winker front	1	0.1	
		33406-148-000	SUB CORD, RH winker rear	1	0.1	
B2	40	33455-148-010	SUB CORD, LH winker front	1	0.1	
		33456-148-000	SUB CORD, LH winker rear	1	0.1	
B2	41	33600-148-000	LAMP ASSY. winker	4	0.2	
B2	42	33606-148-000	STAY R. front winker	1	0.2	
B2	43	33607-148-000	STAY L. front winker	1	0.2	
B1	44	33710-148-610	TAIL LIGHT COMP. + STOP	1	0.2	EH
		33710-148-630	TAIL LIGHT COMP. + STOP	1	0.2	B, FH
		33710-148-820	TAIL LIGHT COMP. + STOP	1	0.2	FH - 1010138 →



Block N°	Ref. N°	Part N°	Description	Req. M	FRT	Remarks
B2	45	35700-099-601	TAIL LIGHT COMP. (ASSY + BULB)	1	0.2	UK. NO STOP
		35711-148-630	TAIL LIGHT COMP.	1	0.2	PH, KH NO STOP
		35711-148-840	TAIL LIGHT COMP.	1	0.2	SH NO STOP
		35711-148-620	TAIL LIGHT COMP.	1	0.2	PH 1013909 →
B2	46	35709-148-000	SEAT, tail light (with stop lamp only)	1	0.2	
B2	47	35709-148-630	SEAT, tail light (without " " " )	1	0.2	
B2	48	34901-099-600	BULB, head light 6V 18/18W	1		UK
		34901-001-8120	BULB, head light 6V/15W			B-MO-MA →1010139
		34901-001-630	BULB, head light 6V/15W	1		KH, SH
		34901-050-621	BULB, head light 6V/ 6W	1		PH (yellow)
		34901-063-690	BULB, head light 6V/ 6W	1		B →1010138
F1	49	34902-148-610	BULB, stop lamp 6V/5W	1		SH, B, PH
F1	50	34903-148-610	BULB, tail lamp 6V/4W	1		PH, B, SH
		34906-099-000	BULB, tail light 12V/3W	1		SH
		34906-099-600	BULB, tail light 6V/5W	1		UK
B2						
F2	51	34905-148-000	BULB, winker 6V/21W	4		
C1	52	35200-148-000	SWITCH ASSY. winker	1	0.1	
		35250-148-000	BUTTON HORN + SWITCH ASSY. WINKER	1	0.4	
C1	53	35300-143-603	SWITCH ASSY. dinner	1	0.1	UK
C1	54	35303-143-601	CORD, dinner switch	1	0.1	UK
B3	55	35400-148-830	RESISTOR ASSY.(with stop lamp only)	1	0.2	
B2	56	37200-099-920	SPEEDOMETER ASSY. KM/H.	1	0.2	B, PH, KH, SH
		37200-143-600	SPEEDOMETER ASSY. M/H.	1	0.2	UK
B2	57	37201-148-000	SPG. SPEEDOMETER SET	1	0.2	
B3	58	38100-148-000	HORN ASSY	1		PH - Dec '76
		38100-099-600	HORN ASSY.	1	0.1	B-MA, UK
C1	59	38110-148-610	BELL	1		
		38102-148-000	CORD HORN	1		PH - Dec '76
D2	60	38300-148-004	RELAY ASSY., winker	1	0.2	
D1	61	38302-148-000	STAY, winker relay	1	0.2	
D2	62	38306-292-000	SUSPENSION, winker relay	1	0.1	
C1	63	38700-050-620	BUTTON HORN	1		



Block N°	Ref. N°	Part N°	Description	Req. M4	FRT	Remarks
E3	64	40210-122-691	ARM R., crank	1	0.2	
E3	65	90609-031-000	PEDAL COMP.R. crank(without reflector)	1		PH, EH, UK, SH
		40215-099-920	PEDAL COMP.R. crank(with reflector)	1		PH
		40215-143-000	PEDAL COMP.R. crank(with reflector)	1		B
E3	66	40220-122-691	ARM L. crank	1	0.2	
E3	67	90709-031-000	PEDAL COMP. L. crank	1		PH, EH, UK, SH
		40225-099-920	PEDAL COMP. L. crank	1		PH
		40225-143-000	PEDAL COMP. L. crank	1		B
E3	68	40230-148-000	SHAFT COMP. DRIVE	1	0.4	1-S
		40230-148-720	SHAFT COMP. DRIVE	1	0.4	V
E3	69	40234-148-000	HUB, drive shaft	2	0.2	
E3	70	40235-093-000	FIN, crank arm	2	0.2	
E3	71	40236-148-720	COLLAR, drive shaft	2	0.2	V
E3	72	40510-148-000	COVER, pedal chain	1		
E3	73	40514-148-000	PIN, cover set	4		
E3	74	40515-148-000	SPG, cover set	4		
E4	75	40520-148-000	COVER, belt	1		1-S
		40520-148-720	COVER, belt	1		V
E3	76	40535-148-005	CHAIN, pedal	1	0.2	B, PH, UK, EH
		40535-148-640	CHAIN, pedal	1	0.2	SH
E3	77	40540-148-020	TENSIONER, chain	1	0.2	
E3	78	40541-148-010	ROLLER, tensioner	2	0.2	
E3	79	40542-148-000	ARM, tensioner	1	0.2	
E2	80	41210-122-810	FREE WHEEL, 16 T.	1	0.2	SH
		41210-148-000	FREE WHEEL, 22 T.	1	0.2	B, PH, UK, EH
E2	81	41215-148-000	GUIDE, free wheel	1		
F3	82	42600-148-610	WHEEL ASSY REAR	1		EH
		42600-148-000	WHEEL ASSY REAR	1	0.2	B, PH, UK, SH
	82 bis	42610-148-000	HUB & PANEL ASSY	1	0.4	
	82 ter	42601-148-000	HUB COMP., rear wheel	1	2.3	
A4 F21	83	42711-099-158	TIRE, wheel (2.00-17)	2	0.4	B, PH, UK, SH, EH-MA → 1
		42711-148-610	TIRE, wheel (2.25-17)	1	0.4	EH-MA → 1 EH-MO → 2
A4 F21	84	42712-099-158	TUBE, wheel	2	0.4	
		42712-148-610	TUBE, wheel 17 X 2.25	1	0.4	EH-MA → 1 EH-MO → 2

FRAME PA 50

Block N°	Ref. N°	Part N°	Description	Qty	PBT	Remarks
A4 F2	85	42713-099-158	FLAP, tire	2	0.4	
B3	86	43100-148-000	PANEL, comp. rear brake	1	0.1	
B2	87	43450-148-010	CABLE COMP. rear brake (with stop lamp only)	1	0.2	
		43450-148-631	CABLE COMP. rear brake (with stop lamp only)	1	0.2	
A4	88	44301-093-003	AXLE, front wheel	1	0.3	
A4 B4	89	44302-093-003	RACE, front wheel cone	2	0.3	
A4	90	44303-093-003	RACE, front wheel ball	2	0.3	
A3 B5	91	44304-148-610	CAP, axle nut	2		SH
A4 B5	92	44311-093-000	COLLAR, fr. axle	2		
	93	44600-099-000	WHEEL ASSY., front	1	0.2	S, FH, UK, SH, EH-MA (93 + 96 + 231 + 232)
		44600-148-690	WHEEL ASSY., front	1	0.2	EH-MO
A4 B5	93 bin	44620-093-000	HUB & PANEL ASSY. FRONT	1	2.0	ASSY. = 93 bin + 99
A4	93 ter	44610-093-000	HUB FRONT WHEEL	1		
A4	94	44604-148-610	COVER, ball race	1	0.2	FH
A4	95	44605-148-610	COLLAR, cover ball race	1	0.2	FH
F2 A4	96	44701-122-690	RIM WHEEL REAR	1	2.0	
	96 bin	44701-122-690	RIM WHEEL FRONT	1		
A4	97	44800-099-003	GEAR BOX ASSY. speedometer	1	0.2	
B3	98	44850-148-000	CABLE COMP. speedometer	1	0.1	
B5	99	45100-093-013	PANEL FRONT BRAKE	1	0.1	
	99 bin	45050-093-001	PANEL ASSY. front brake	1	0.1	

Stock #	Ref. #	Part #	Description	Req. #	FRT	Remarks
72 73 75	100	45120-093-003	SHOE COMP. brake	4	0.1	100 = 101
75 75	101	45133-093-003	SPG. brake shoe	4	0.1	
75	102	45450-148-010	CABLE COMP., front brake	1	0.1	
02	103	50100-148-000XB	BODY COMP. frame	1	4.5	
		50100-148-000C	BODY COMP. frame	1	4.5	
		50100-148-000E0	BODY COMP. frame	1	4.5	
		50100-148-000KB	BODY COMP. frame	1	4.5	
		50100-148-000GL	BODY COMP. frame	1	4.5	
02 75	104	50301-093-003	RACE, steering ball	2	0.6	
EE	105	50328-148-000	HOLDER BATTERY upper	1		
		50329-148-000	HOLDER BATTERY lower	1		
D4	106	50500-148-000B	STAND COMP. MAIN	1		
		50500-148-010B	STAND COMP. MAIN	1		
D4	107	50501-148-000	SHAFT, main stand	1	0.2	
		51500-148-000XB	FRONT FORK ASSY.	1	0.3	0/1010112
		51500-148-010XB	FRONT FORK	1	0.3	1010113 →
		51500-148-000H0	FRONT FORK ASSY.	1	0.3	0/1010112
		51500-148-010H0	FRONT FORK	1	0.3	1010113 →
		51500-148-000GL	FRONT FORK ASSY.	1	0.3	0/1010112
		51500-148-010GL	FRONT FORK	1	0.3	1010113 →
		51500-148-000ME	FRONT FORK ASSY.	1	0.3	0/1010112
		51500-148-010ME	FRONT FORK	1	0.3	1010113 →
		51500-148-000C	FRONT FORK ASSY.	1	0.3	0/1010112
		51500-148-010C	FRONT FORK	1	0.3	1010113 →
34	108	5150A-148-310	COLLAR, slide pipe	2	0.1	1010113 →
33	109	51105-148-010	DUST, seal front fork	2	0.3	
33	111	51510-148-000XB	FORK COMP. front	1	0.3	0/1010112
		51510-148-020XB	FORK COMP.	1	0.3	1010113 →
		51510-148-000H0	FORK COMP. front	1	0.3	0/1010112
		51510-148-020H0	FORK COMP.	1	0.3	1010113 →
		51510-148-000GL	FORK COMP. front	1	0.3	0/1010112
		51510-148-020GL	FORK COMP.	1	0.3	1010113 →
		51510-148-000ME	FORK COMP. front	1	0.3	0/1010112
		51510-148-020ME	FORK COMP.	1	0.3	1010113 →

FRAME PA 50

Block N°	Ref. N°	Part N°	Description	Req. Mt	FRT	Remarks
B3	111	51510-148-0000	FORK COMP. front	1	0.3	0/1010112
		51510-148-0200	FORK COMP. front	1	0.3	1010113 →
B4	112	51520-148-000	PIPE SLIDE, fr. fork right compl.	1	1.4	0/1010112
		51520-148-020	PIPE SLIDE, fr. right			1010113 →
B4	113	51530-148-000	PIPE SLIDE, fr. fork left compl.	1	1.4	0/1010112
		51530-148-030	PIPE SLIDE, fr. left			1010113 →
		52100-148-610	FORK COMP. rear	1		SH
D5	114	52100-148-010	FORK, comp. rear	1	0.9	B, FN, UK, SH
04	115	52101-148-640	BRACKET, rear fork right	1	0.4	SH
04	116	52102-148-640	BRACKET, rear fork left	1	0.4	SH
E3	117	52112-148-000	COLLAR, rear fork	2		
E2	118	52400-148-000XL	CUSHION ASSY. rear	2	0.1	
E2	119	52144-027-000	BUSH, rear cushion	8	0.1	
E3	120	52485-093-000	COLLAR, rear cushion	4	0.1	
B1	121	53002-122-610B	HANDLE GRIP, throttle assy.	1	0.1	
G2	122	53100-148-000	HANDLE, steering pipe	1	0.2	
G2	123	53111-148-010	HOLDER, handle pipe	2		
B1	124	53141-122-690	PIPE, throttle grip	1		
B1	125	53154-093-003	SPG., brake throttle grip	1		
B1	126	53165-093-003B	RUBBER, grip R.	1	0.1	
G2	127	53166-093-003B	RUBBER, grip L.	1	0.1	
B1	128	53170-148-610	LEVER R., handle grip	1	0.1	
G2	129	53172-093-610	HOLDER COMP., handle grip L.	1	0.1	
G2	130	53180-148-610	LEVER L., handle pipe	1	0.1	
B1	131	53182-122-690	LEVER	1	0.1	
G2	132	53211-093-003	RACE, top steering cone	1	0.5	
B3	133	53212-093-003	RACE, bottom steering cone	1	0.6	
G2						
B3	134	53213-093-003	CAGE, ball assy.	2	0.5	
G2	135	53230-148-300XL	BRIDGE, fork top	1	0.2	
B2	136	53240-148-000	PLATE, under	2	0.2	
B2	137	53600-148-000	LOCK, key steering handle	1		

Block N°	Ref. N°	Part N°	Description	Req N°	FRT	Remarks	
34	139	61100-148-010XB	FENDER, front paint	1	0.2	B, FH, UK	
		61100-148-010ND	FENDER, front paint	1	0.2	B, FH, UK	
		61100-148-010GL	FENDER, front paint	1	0.2	B, FH, UK	
		61100-148-010ME	FENDER, front paint	1	0.2	B, FH, UK	
		61100-148-010C	FENDER, front paint	1	0.2	B, FH, UK	
		61100-148-611XB	FENDER, front paint	1	0.2	EH	
		61100-148-611ND	FENDER, front paint	1	0.2	EH	
		61100-148-611GL	FENDER, front paint	1	0.2	EH	
		61100-148-611ME	FENDER, front paint	1	0.2	EH	
		61100-148-611C	FENDER, front paint	1	0.2	EH	
		61100-148-821	FENDER, front inox	1	0.2	UK, SH	
		61100-148-811	FENDER, front inox	1	0.2	EH	
	32	140	61301-148-000	CASE, head light	1	0.1	
	33	141	61304-148-000	SPG, set head light	1		
	32 C2	142	61308-148-000	CAP, top bridge	2		
	D1	143	77100-148-000	SEAT ASSY	1		
	C1	144	77200-148-000	SEAT COMP.	1	0.3	
		80100-148-610	FENDER COMP. rear paint	1	0.3	EH	
		80100-148-860	FENDER COMP. rear inox	1	0.3	UK	
		80100-148-800XB	FENDER COMP. rear paint	1	0.3	UK	
		80100-148-800GL	FENDER COMP. rear paint	1	0.3	UK	
		80100-148-800ME	FENDER COMP. rear paint	1	0.3	UK	
		80100-148-800C	FENDER COMP. rear paint	1	0.3	UK	
D2	145	80100-148-000ND	FENDER COMP. rear paint	1	0.3	FH	
		80100-148-000GL	FENDER COMP. rear paint	1	0.3	FH	
		80100-148-000ME	FENDER COMP. rear paint	1	0.3	FH	
		80100-148-000C	FENDER COMP. rear paint	1	0.3	FH	
		80100-148-630ND	FENDER COMP. rear paint	1	0.3	B, FH	
		80100-148-630GL	FENDER COMP. rear paint	1	0.3	B, FH	
		80100-148-630ME	FENDER COMP. rear paint	1	0.3	B, FH	
		80100-148-630C	FENDER COMP. rear paint	1	0.3	B, FH	
		80100-148-820	FENDER COMP. rear inox	1	0.3	SH	
		80100-148-840	FENDER COMP. rear inox	1	0.3	SH	



FRAME PA 50

Block N°	Ref. N°	Part N°	Description	Req. N°	FRT	Remarks
D2	145	80100-148-670NO	FENDER COMP. rear paint	1	0.3	B-MA
		80100-148-670GL	FENDER COMP. rear paint	1	0.3	B-MA
		80100-148-670ME	FENDER COMP. rear paint	1	0.3	B-MA
		80100-148-670C	FENDER COMP. rear paint	1	0.3	B-MA
E2	146	80200-148-010	PIPE, guard	1		
		81200-148-800XB	CARRIER, comp. rear	1	0.2	UK
		81200-148-800GL	CARRIER, comp. rear	1	0.2	UK
		81200-148-800ME	CARRIER, comp. rear	1	0.2	UK
		81200-148-800C	CARRIER, comp. rear	1	0.2	UK
E1	147	81200-148-000XB	CARRIER, comp. rear	1	0.2	B, PH, EH, SH
		81200-148-000NO	CARRIER, comp. rear	1	0.2	B, PH, EH, SH
		81200-148-000GL	CARRIER, comp. rear	1	0.2	B, PH, EH, SH
		81200-148-000ME	CARRIER, comp. rear	1	0.2	B, PH, EH, SH
		81200-148-000C	CARRIER, comp. rear	1	0.2	B, PH, EH, SH
A2	148	81300-148-010	CARRIER ASSY., front	1	0.1	
B3	149	81301-148-010	BAND A, front carrier	2	0.1	
B3	150	81302-148-010	BAND B, front carrier	2	0.1	
A2	151	81310-148-000	BINDER	2		
A2	152	81320-148-000	SPG., binder	2		
E1	153	81400-148-010	SUB CARRIER, rear	1		
D1	155	83500-148-020	BOX TOOL	1		
D1	156	83513-044-000	DRIVER	1		
D1	157	83517-122-000	BOX WRENCH 21	1		
C2	158	83600-148-000	COVER R. floor	1		
D3	159	83700-148-000	COVER L. floor	1		
F2	160	84208-148-650	HOLDER, insurance plate	1		B-MA
		84701-099-600	BRACKET A, number plate	1	0.1	UK
		84702-099-600	BRACKET B, number plate	1	0.1	UK
D3	161	84704-148-000	COLLAR, ignition coil	2		
C3	162	87121-148-000	EMBLEM, fuel tank	2		B, SH, UK
		87121-148-610	EMBLEM, fuel tank	2		EH, UK, F
D1	164	89010-148-000	TOOL SET	1		B, PH, UK, EH, SH
D1	165	89101-063-000	BAG TOOL	1		



Block N°	Ref. N°	Part N°	Description	Req. M	FRT	Remarks
24	166	89400-148-000	PUMP ASSY.	1		
22	167	90046-300-000	BOLT HEX 8 X 55	1		
24	168	90103-148-000	BOLT engine hanger 10 X 145	1		
21	169	90114-093-013	SCREW, handle grip lever pivot	2		
21	170	90115-093-003	SCREW, handle lever bracket	2		
23	171	90122-148-000	BOLT, floor cover set	4		
D1	172	80200-148-730	STAY, winker rear right	1		B, EH, FH
		80300-148-730	STAY, winker rear left	1		
22	173	90201-093-000	WASHER, plain 26 mm.	1		
24	174	90300-099-000	E-RING 8 mm.	2		
21	175	90301-093-003	NUT, steering head stem	1		
21	176	90302-093-000	CAP, steering stem nut	1		
24	178	90312-099-003	NUT C., 11 mm.	1		
24	179	90313-093-003	NUT B., 11 mm.	2		
25	180	90314-093-003	NUT A., 11 mm.	1		
24	181	90315-099-003	NUT D., 11 mm.	2		
22	182	94101-080	WASHER, plain 8,5 Ø	2		
24	183	90481-705-000	WASHER, 10,5 mm.	1		
22	184	90501-124-000	WASHER, front cover setting	4		
25	185	94101-11000	WASHER, 11 mm. (DIN 126)	2		
22	186	51571-148-000	CLIP, cable	1		
24	187	90505-093-003	WASHER, plain 29,2 mm.	2		
23	188	90545-044-000	WASHER, crank arm	2		
23	189	90554-240-000	WASHER B., chain case setting	4		
23	190	90581-701-000	WASHER, 18 mm. X 6,4 mm.	2		
23	191	92000-06012-0A	BOLT HEX 6 X 12	4		TAIL PIPE → 1 CHAIN TENSIONER → 1
23	192	92000-06015-0A	BOLT HEX 6 X 15	2		HORN ASSY → 2 RESISTOR ASSY → 2
23	193	92000-06016	BOLT HEX 6 X 16			FR. CARRIER → 2
22	194	92000-06020-0A	BOLT HEX 6 X 20	5		WINKER → 2 + Rear Fender
22	195	92000-06025-0A	BOLT HEX 6 X 30	1		TAIL PIPE → 1 + Rear Per
22	196	92000-08018-0A	BOLT HEX 8 X 18	1		FRONT CARRIER → 2 PANEL → 1
24	197	92000-08028-0A	BOLT HEX 8 X 28	5		
24	198	92000-08035-0A	BOLT HEX 8 X 35	1		
24	199	92000-08040-0A	BOLT HEX 8 X 40	3		
24	200	92000-10012-0A	BOLT HEX 10 X 12	1		
23	202	92500-10035-0A	BOLT HEX, cap 10 X 35	2		

FRAME PA 50

Block N°	Ref. N°	Part N°	Description	Req. N°	FRT	Remarks
F2	203	93500-04012	SCREW PAN 4 X 12			INSURANCE PLATE → 2
E1	205	92000-06012-08	BOLT HEX 6 X 12	3		BATTERY → 2 WINKER RELAY →
B3	206	93500-06015-0A	SCREW PAN 6 X 15	3		STOP LAMP → 1 BRACKET → 2
F1	207	93500-06032-0A	SCREW PAN 6 X 32			STOP LAMP → 1
D3	208	93500-06040-0A	SCREW PAN 6 X 40	2		
B4	209	94001-04000	NUT HEX 4 mm.			INSURANCE PLATE → 2
B2	210	94001-05000	NUT HEX 5 mm.			WITHOUT STOP LAMP → 1
D2	211	94001-06000	NUT HEX 6 mm.	7		STOP LAMP → 2 TAIL PIPE → 1 BATTERY → 2 TAIL LIGHT UK → 5 HORN → 2
C2	212	94001-08000	NUT HEX 8 mm.	11		
D4	213	94001-10000-08	NUT HEX 10 mm.	1		
B2	215	92028-10028	BOLT HEX 10 X 28	2		
D2	216	94021-10000	NUT HEX CAP 10 mm.	2		
B4	217	94101-04000	WASHER PLAIN 4 mm.			INSURANCE PLATE → 4
D2	218	94101-05000	WASHER PLAIN 5 mm.			WITHOUT STOP LAMP → 1
E1	219	94101-06000	WASHER PLAIN 6 mm.	4		HORN → 2 TAIL PIPE → 2 BATTERY → 4 WINKER RELAY → 2 DR. WINKER STAY → 2 RESISTOR → 2
C4	220	94101-08000	WASHER PLAIN 8 mm.	18		FR. CARRIER → 2
B4	221	94101-10000	WASHER PLAIN 10 mm.	14		
D3	222	94111-06000	WASHER SPG. 6 mm.	2		TAIL PIPE → 2 BATTERY → 2 WINKER RELAY → 1 IGN. COIL → 2 TAIL. UK → 3
C4	223	94111-08000	WASHER SPG. 8 mm.	15		FR. CARRIER → 2
D4	224	94111-10000	WASHER SPG. 10 mm.	1		
C3	225	95001-45270-40	TUBE, fuel	1		
C3	226	95002-02080	CLIP BB TUBE	2		
C3	227	95014-61100	BAND A1, wire	1		
D4	228	95014-71401	SPG. D, main stand	1		ER → 2
B2	229	96150-62020-10	BEARING BALL RADIAL 6202	1	0.5	
A4	230	96211-07000	BALL STEEL	22	0.5	
B4	231	97188-11216-10	SPOKE A, 13 X 188	18	0.1	
	231 b18	97000-12001	WHIPPLE SPOKE 13	36		

Stock N°	Ref. N°	Part N°	Description	Req. Mt	FRT	Remarks
B4	232	97087-11217-10	SPOKE A, 13 X 188,5	18	0.1	
F2	233	97160-21158-10	SPOKE A, 12 X 159	18	0.1	
		97064-21158-10	SPOKE A, 12 X 159	18	0.1	
	233 h1a	97000-22001	NIPPLE SPOKE 12	36		
D1	234	98200-10700	FUSE, A 07			WINKER → 1
E7	235	33705-148-000	BODY, taillight	1		B, FH, EH
E1	236	33705-148-000	LENS, taillight	1		FH, B
		33703-148-610	LENS, taillight	1		EH
E1	237	33704-148-000	SOCKET COMP. taillight	1		B, FH, EH
		33705-099-600	PLATE, taill. lens holder	1		UK
E2	238	33705-148-630	BODY, taillight	1		FH, EH, SH
E2	239	33701-099-601	LENS, taillight	1		UK WIPAC
		33703-148-630	LENS, taillight	1		FH, EH
		33703-148-840	LENS, taillight	1		SH
F1	240	90118-148-000	SCREW tapping 4 mm.			STOP LAMP → 2
E2	241	90118-148-630	SCREW tapping 3 mm.			WITHOUT STOP LAMP → 1
	242	33601-148-000	BODY, winker	4		
	243	33602-148-000	LENS, winker	4		B, F, G
	244	90120-148-000	SCREW, winker	4		
	245	94111-04000	WASHER SPG. 4 mm.			INSURANCE PLATE → 2
	246	90401-099-930	WASHER, R.F. pivot nut	2		
	247	31503-148-000	COLLAR DISTANCE BATTERY	1		
	248	32106-148-000	CONNECTOR A., fuse	1		
		32112-041-000	CONNECTOR A., fuse	1		
		37251-148-000	HUBBER, fuse holder	1		
E2	249	90483-148-000	WASHER TS 4 mm.	1		BATTERY
D3	250	52126-148-000	SILENCER CHAIN	1		
E3	251	51514-148-000	GROMMET BOTTOM BR	2		
C1	252	33701-148-000	BAND STEERING	1		
E2	253	50164-063-000	CAP, CHANGE CABLE HOLE			SH → 2 UK - L → 2 UK - VT, → 4
E2	254	50165-148-000	GROMMET WINKER REAR	2		
D1	255	83501-148-000	SPRING BOX TOOL	1		1000100 →
C4	256	61104-148-300	CABLE GUARD	2		FH STD + F V (December
C5	257	90105-148-000	NUT JOINT EXH PIPE	2		
B3	258	90130-148-000	PAN WASHER 6 mm.	2		STAY HORN + STAY REGISTO

FRAME PA 50

Block N°	Ref. N°	Part N°	Description	Recq. N°	FRT	Remarks
E2	259	92000-05015	BOLT HEX 8 X 15	2		STAY WINKER REAR
F1	260	93500-05012-0A	SCREW PAN 6 X 12	1		
D2	261	80112-099-000	RUBBER A. REAR FENDER	3		
D2	262	80113-099-000	RUBBER B. REAR FENDER	3		
E3	263	40536-122-003	JOINT PEDAL CHAIN	1		B, PH, UK, EH
	264	40536-148-003	JOINT PEDAL CHAIN	1		SH
E2 D2	265	80111-099-000	COLLAR distance	3		Rear fender

1308723



**HONDA MOTOR**

DC 4000-4-78