

Dayshake – Fietsstoeltje Achterzitje

Installatie instructies



Stap 1. Maak de 3 bouten in het zitje los. Bevestig de rugleuning met de losgehaalde bouten.



Stap 2. Haal de metalen balkjes los van het zitje.



Stap 3. Plaats het stoeltje op de juiste positie op de bagagedrager.



Stap 4. Plaats de metalen balkjes terug en draai de moertjes stevig vast.

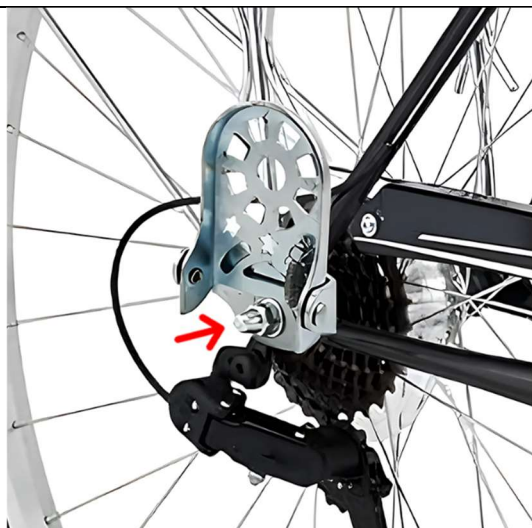

Stap 5: Haal de moer van je achterwiel los. Plaats de voetsteuntjes om te bout en draai de moer weer stevig vast.



Stap 6: Bevestig de armsteun aan de zadelpen met de bijgeleverde bouten en moeren. Draai deze stevig vast.

Dayshake – Bicycle Rear Seat Installation instructions



Step 1. Loosen the 3 bolts in the seat. Fix the backrest with the loosened bolts.



Step 2. Remove the metal bars from the seat.



Step 3. Place the seat in the correct position on the carrier.



Step 4. Replace the metal bars and tighten the nuts firmly.

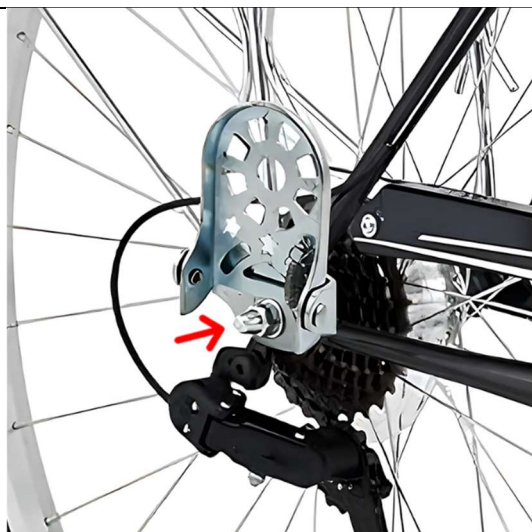

Step 5: Loosen the nut on your rear wheel. Place the footpegs around the bolt and tighten the nut firmly again.



Step 6: Attach the armrest to the seat post with the bolts and nuts provided. Tighten these securely.