

Awning Assembly Instructions

3x2.5M 2.5x2M

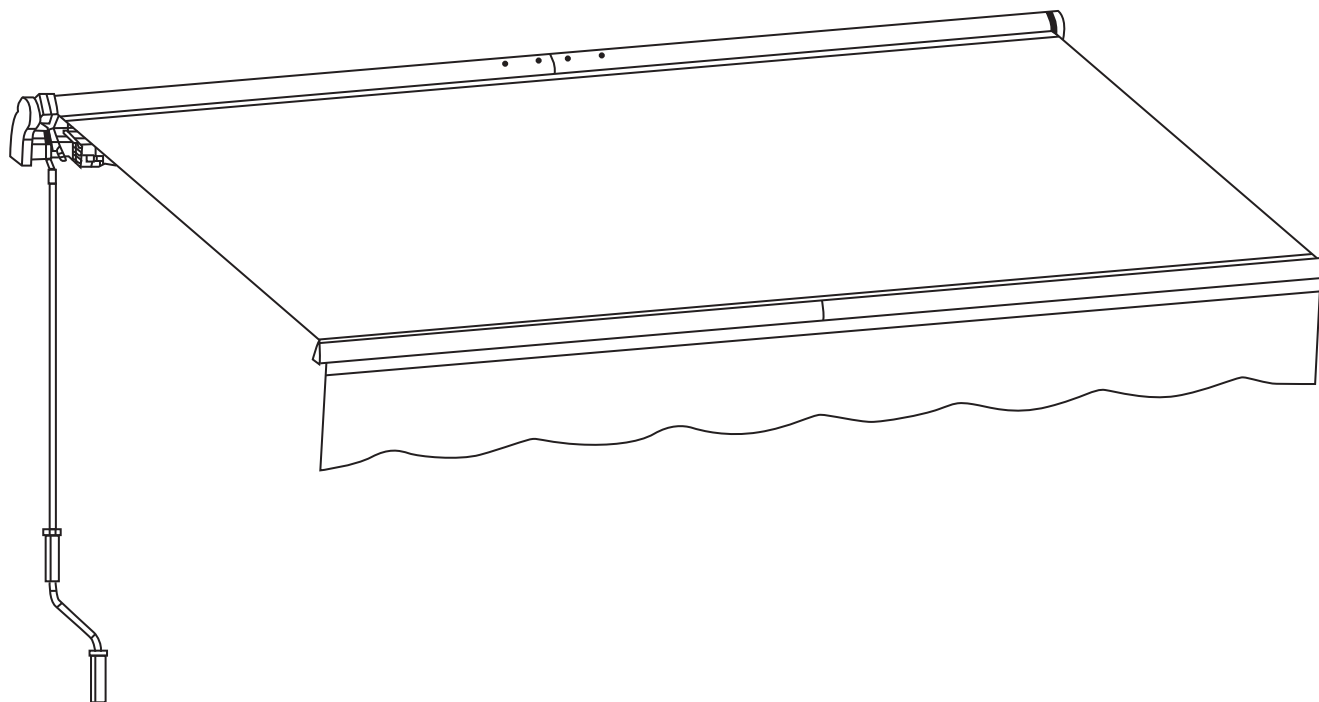

Thank you for purchasing our retractable awning! We hope you will find joy in our product for many years to come.







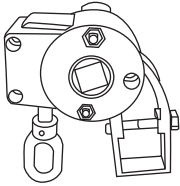
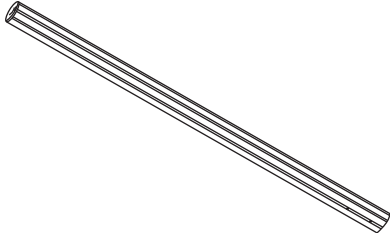
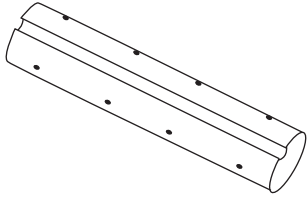
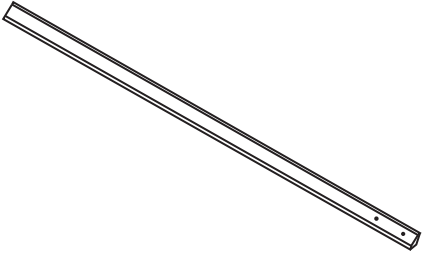
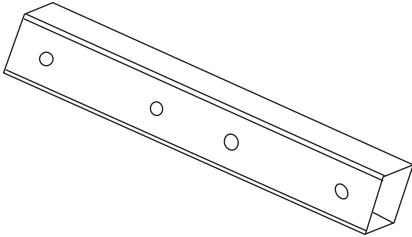
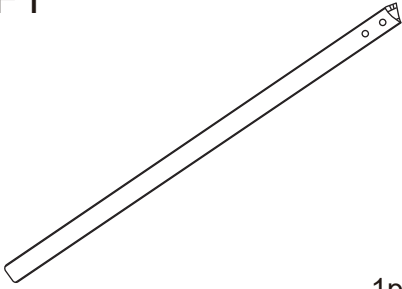
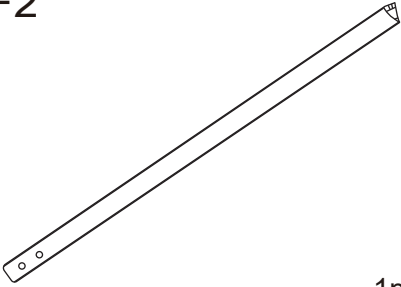
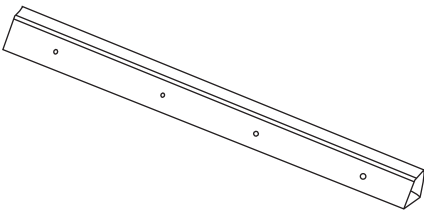
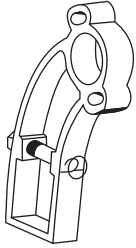
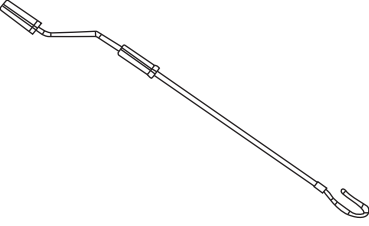
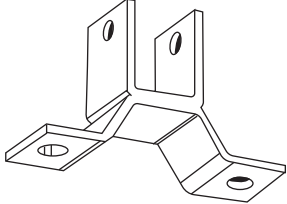
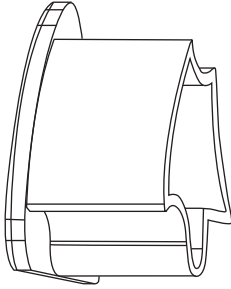
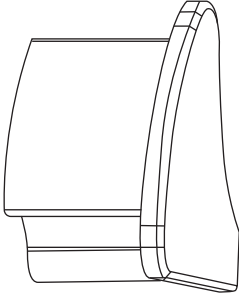
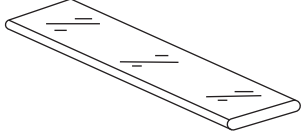
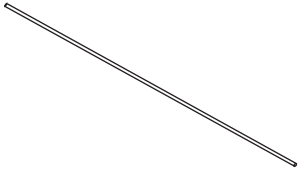

To ensure your personal safety during installation and to get the most out of your investment, please read this entire manual before beginning the installation process.

We recommend installing this awning by two people. If you feel that this process is too difficult to do on your own, we advise that you seek assistance from a local building or home improvement contractor.

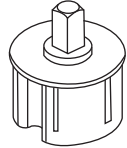
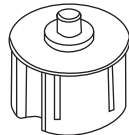
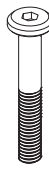
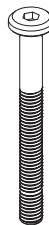

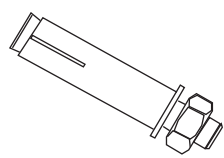
Please contact our customer service hotline for help if you have any problem or need assistance when assembling, have missing or defective parts, or any other issues, we will try our best to help solve your problems.

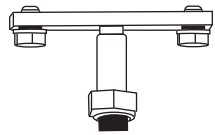
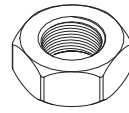

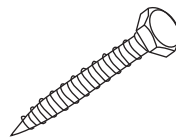
Part list:
Optional Installation

<p>A</p>  <p>1pc</p>	<p>B</p>  <p>2pcs</p>	<p>C</p>  <p>1pc</p>
<p>D</p>  <p>2pcs</p>	<p>E</p>  <p>1pc</p>	<p>F1</p>  <p>1pc</p>
<p>F2</p>  <p>1pc</p>	<p>G</p>  <p>1pc</p>	<p>H</p>  <p>1pc</p>
<p>I</p>  <p>1pc</p>	<p>J</p>  <p>2pcs</p>	<p>K1</p>  <p>1pc</p>
<p>K2</p>  <p>1pc</p>	<p>L</p>  <p>1pc</p>	<p>M</p>  <p>3pcs</p>

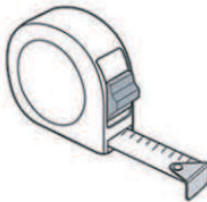
<p>N1</p>  <p>1pc</p>	<p>N2</p>  <p>1pc</p>	<p>O1</p>  <p>1pc</p>	
<p>O2</p>  <p>1pc</p>	<p>P1</p>  <p>M6x40 4pcs</p>	<p>P2</p>  <p>M8x55 2pcs</p>	<p>Q</p>  <p>M8 2pcs</p>
<p>R</p>  <p>M6 4pcs</p>	<p>S</p>  <p>4pcs</p>	<p>T</p>  <p>M5x16 16pcs</p>	<p>U</p>  <p>2pcs</p>
<p>V</p>  <p>M8 2pcs</p>	<p>W</p>  <p>2pcs</p>	<p>X</p>  <p>M3x10 2pcs</p>	<p>Z</p>  <p>M10x72 4pcs</p>

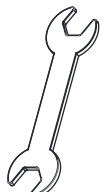
Please prepare the below listed tools before assembly (not included).

<p>Measuring tape</p>	<p>Non-metallic mallet</p>	<p>Wrench (wrenches of M17 and M14)</p>
		

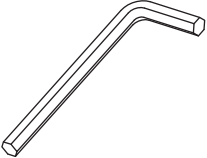
Cross screwdriver	Power drill with 14 mm drilling bit	chalk line leveler or water level	8 mm wrench
			

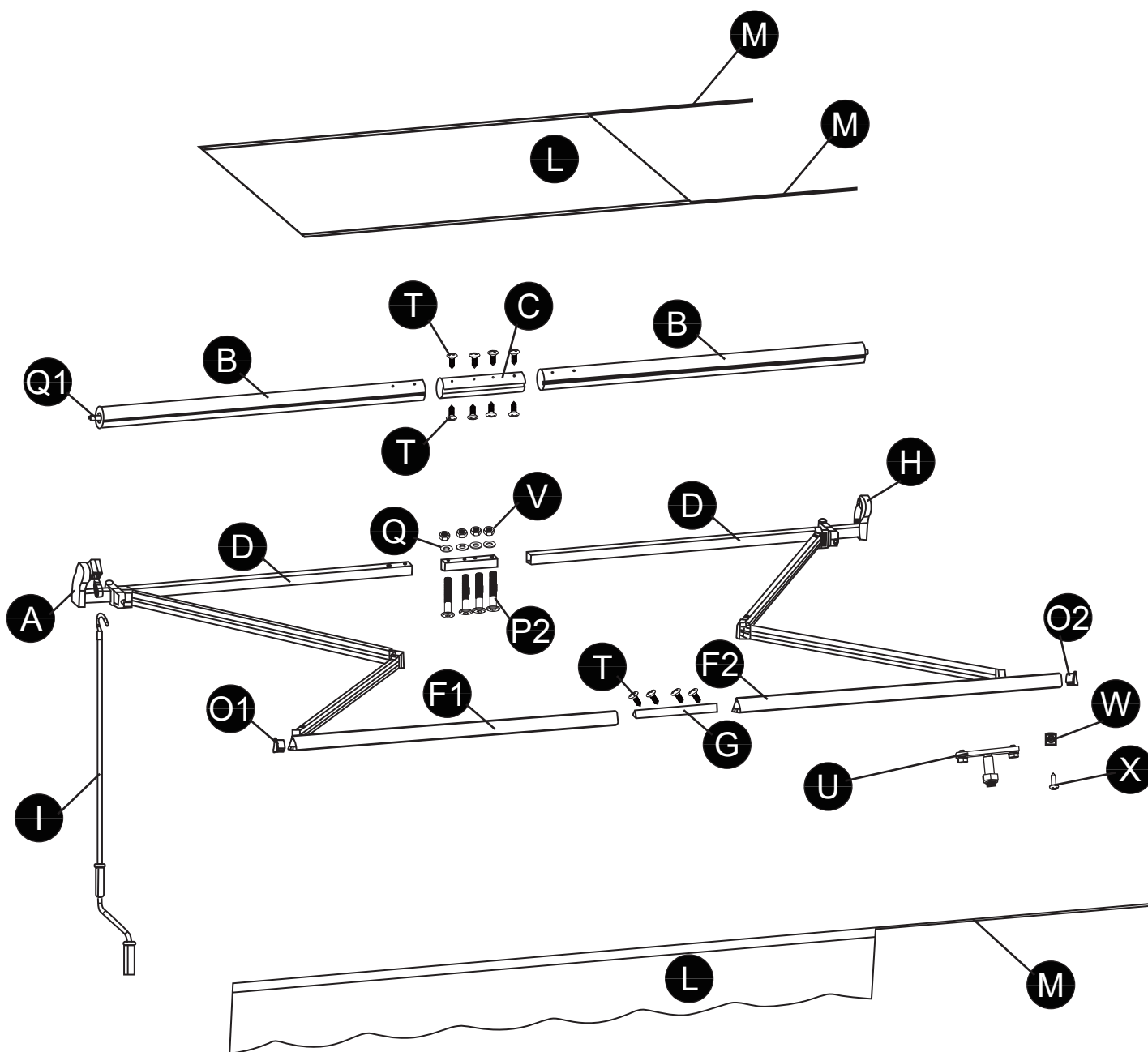

Preparing your workspace

1. Before you begin, it is best to lay out all necessary tools.
Refer to the required tools section for the list of necessary tools.

WARNING

Do NOT remove the safety wrap that holds the awning arms down.
Serious injury can result from removing the wrap too soon.

2. Open the awning box and unwrap each piece carefully to avoid damaging the product.
3. Lay out each piece of the awning to ensure that all pieces are present.
Refer to the parts diagram for detailed information regarding parts.
4. Open the small, inner box that contains the small parts and lay them out as well.

Assembly:

Step 1: Roller assembly

Keep the rollers aligned, assemble the roller with the connectors and secure it with the corresponding bolts as shown in the figures below:

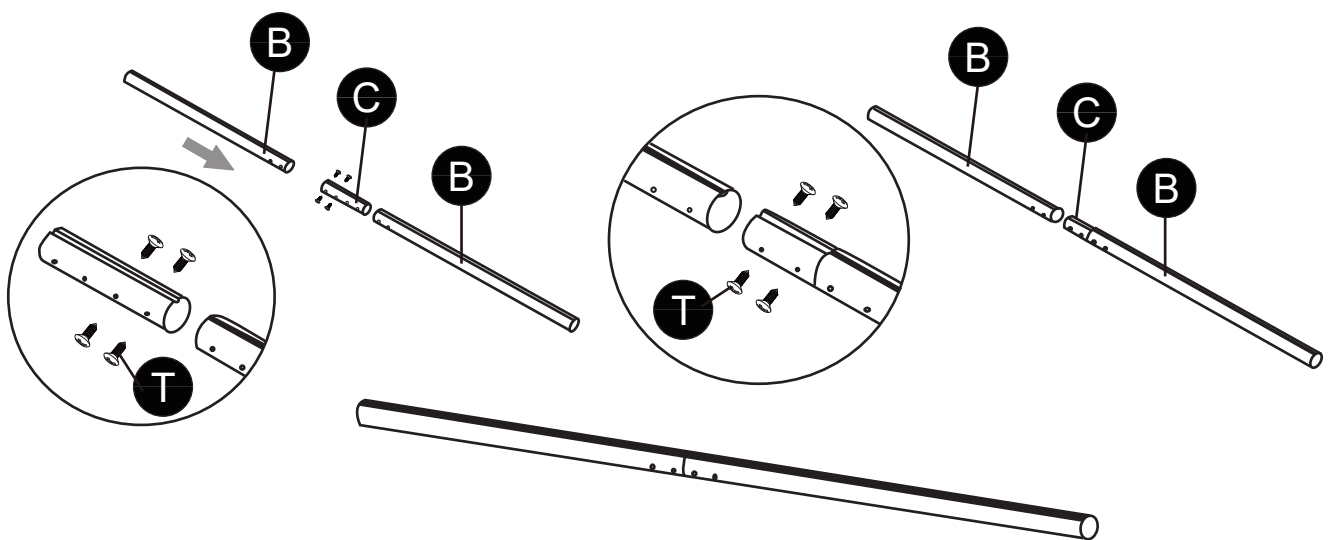

Step 2: Support tube rod and arm assembly

Align the four sides, connect the support tube rods with the connectors and secure them with the corresponding bolts as shown in the figures below:

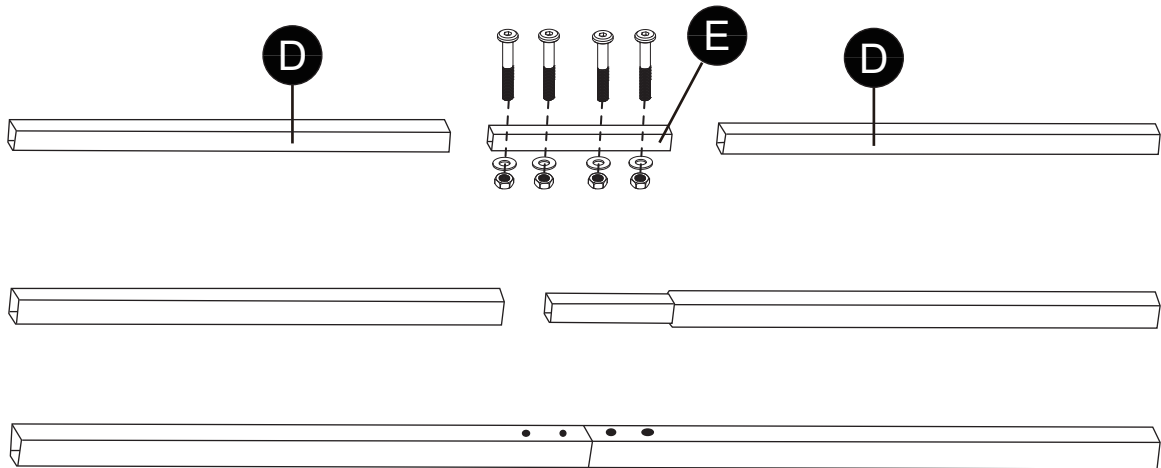

Then assemble the arms to the support tube rods as shown in the figures below. The two arms need to point in the same direction, the rope of the arm cannot be unlocked until the whole assembly is complete.

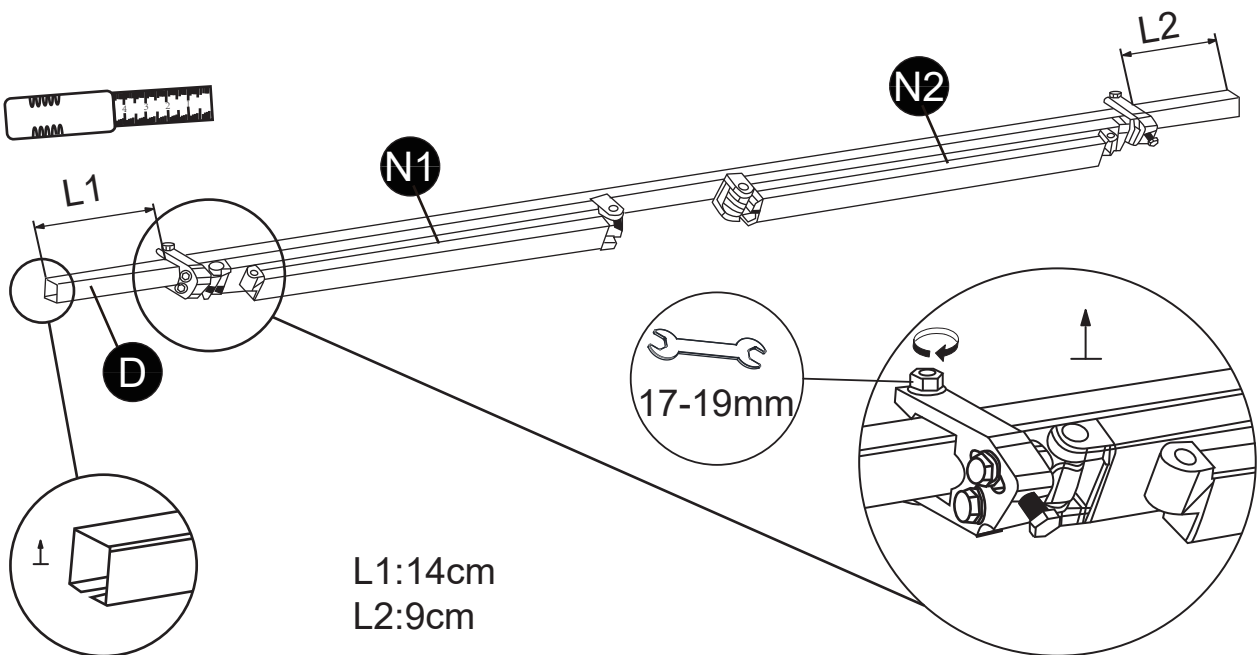

Step3: Front bar assembly

Connect the front bar with the connectors (pos.7) and secure it with the corresponding bolts as shown in the figures below (please keep the front bar aligned).

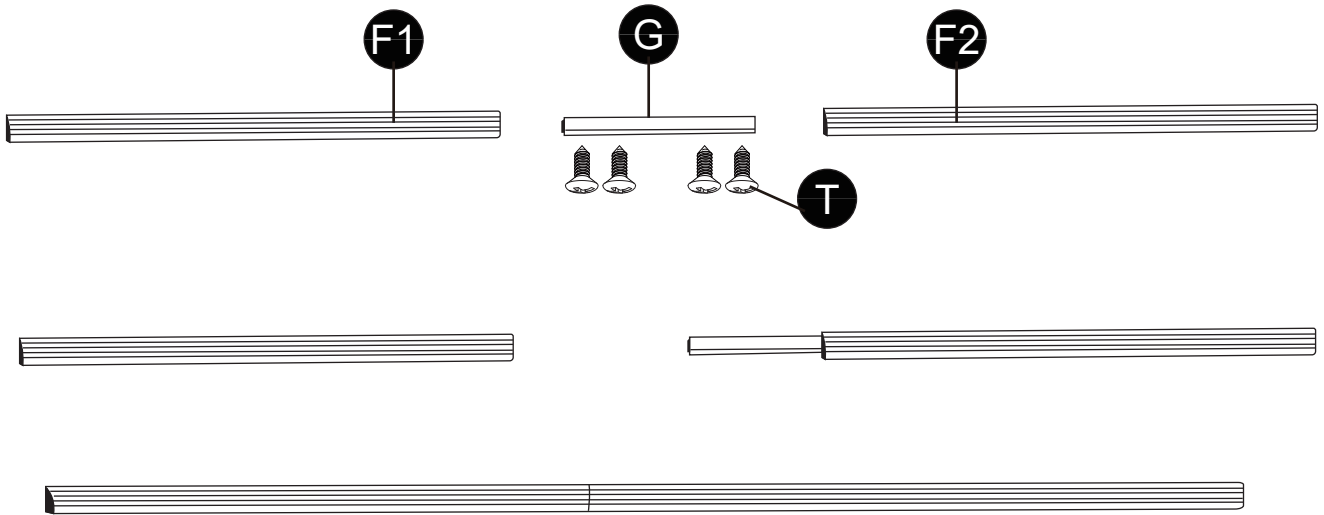

Step 4: Front bar wrist support assembly

Slide the feet (pos. 18) into the front bar without tightening. As shown in the figure below:

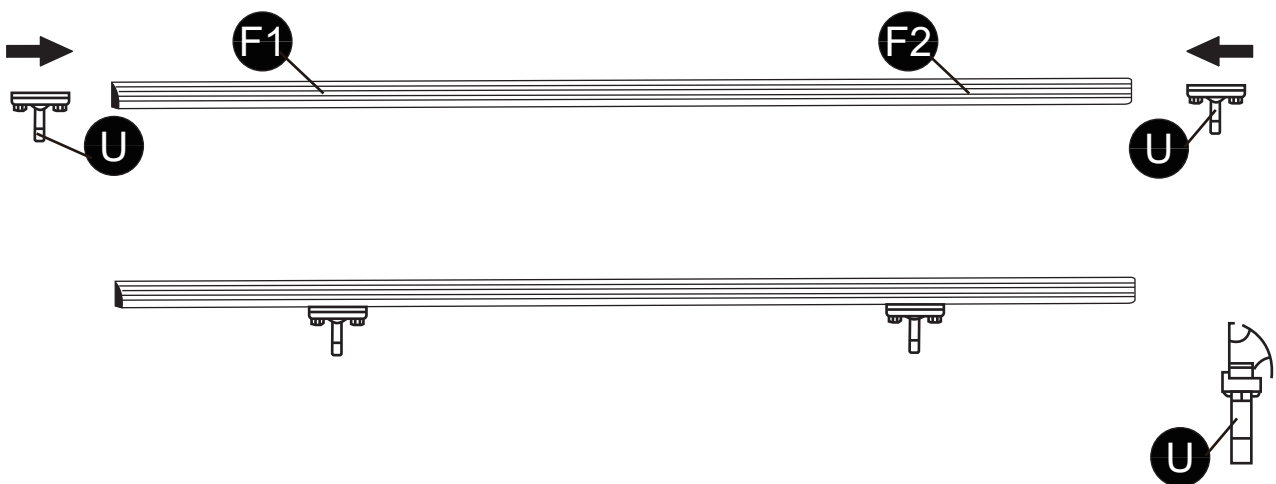

Step 5: Arms with front bar assembly

Put the front bar feet bolt (pos. 18) through the hole of the small arm, then position the front bar. After positioning, tighten the nut with a wrench, as shown in the figure below:

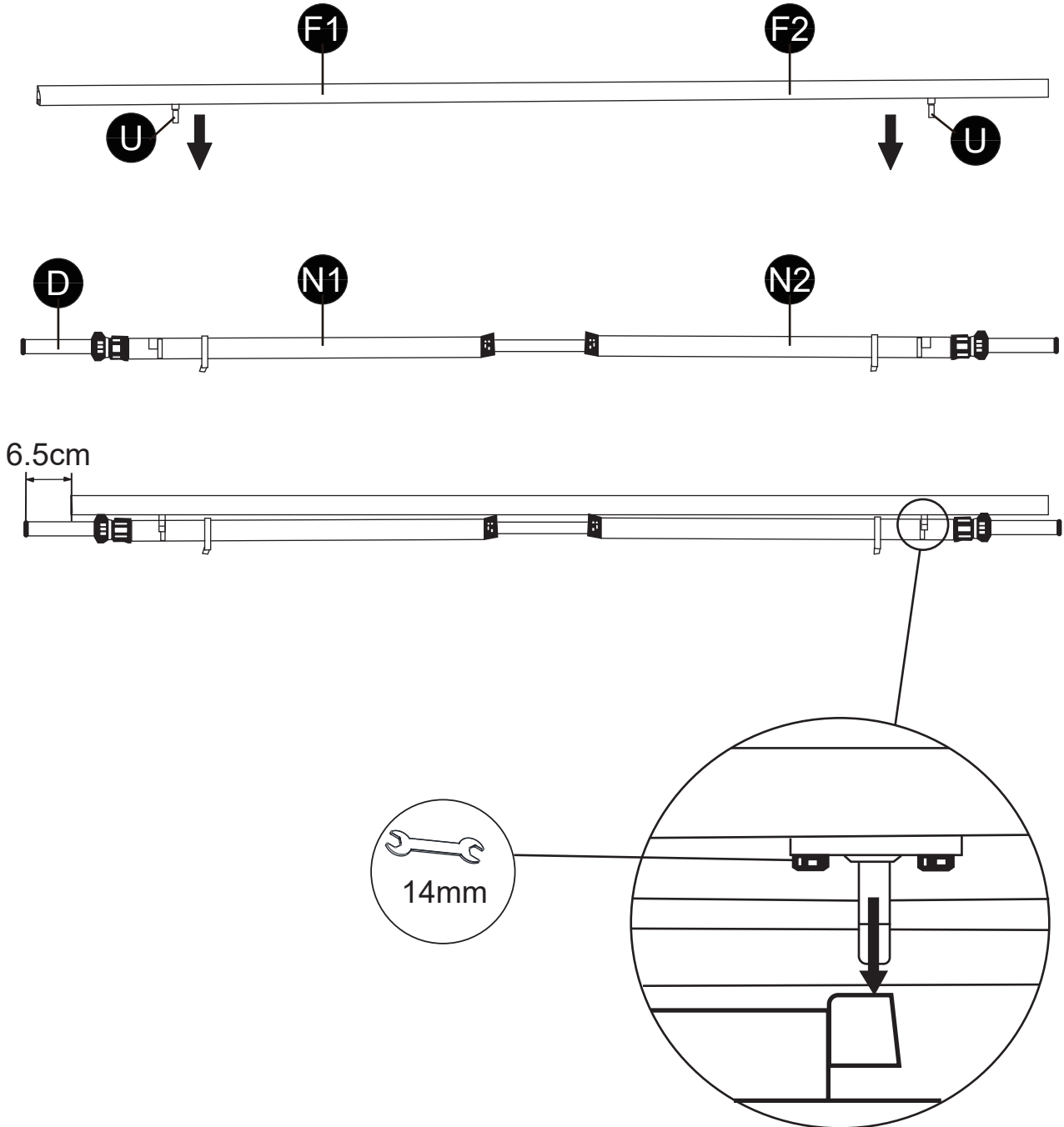

Step 6: Link the self-locking nut

Place the self-locking nuts onto the screws which are located at the bottom of the feet and tighten them firmly with a wrench, as shown in the figure below:

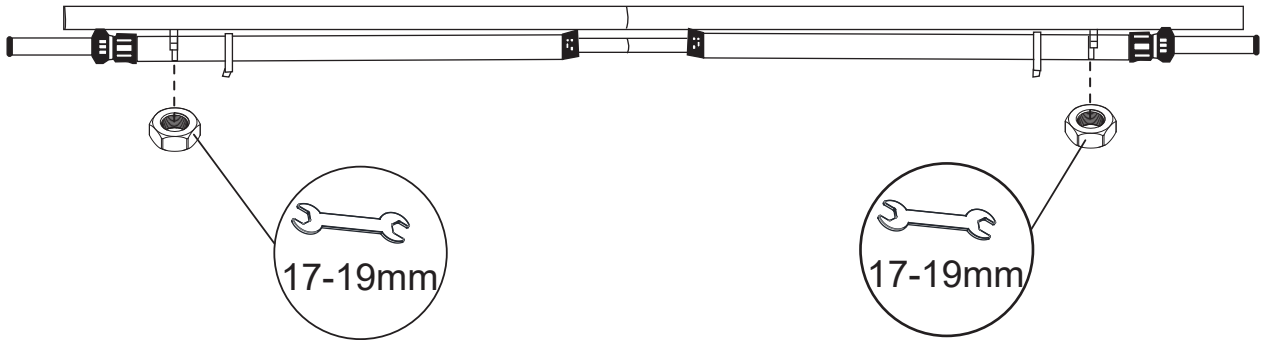

ATTENTION: BEFORE TIGHTENING THE NUTS, ENSURE THAT THE ARMS ARE PROPERLY ALIGNED.

Step7: Left roller support with gear box assembly

Hammer the left roller support with gear box into the left end of the support tube rod with a hammer, then tighten the left hexagon bolt. As shown in the figure below:

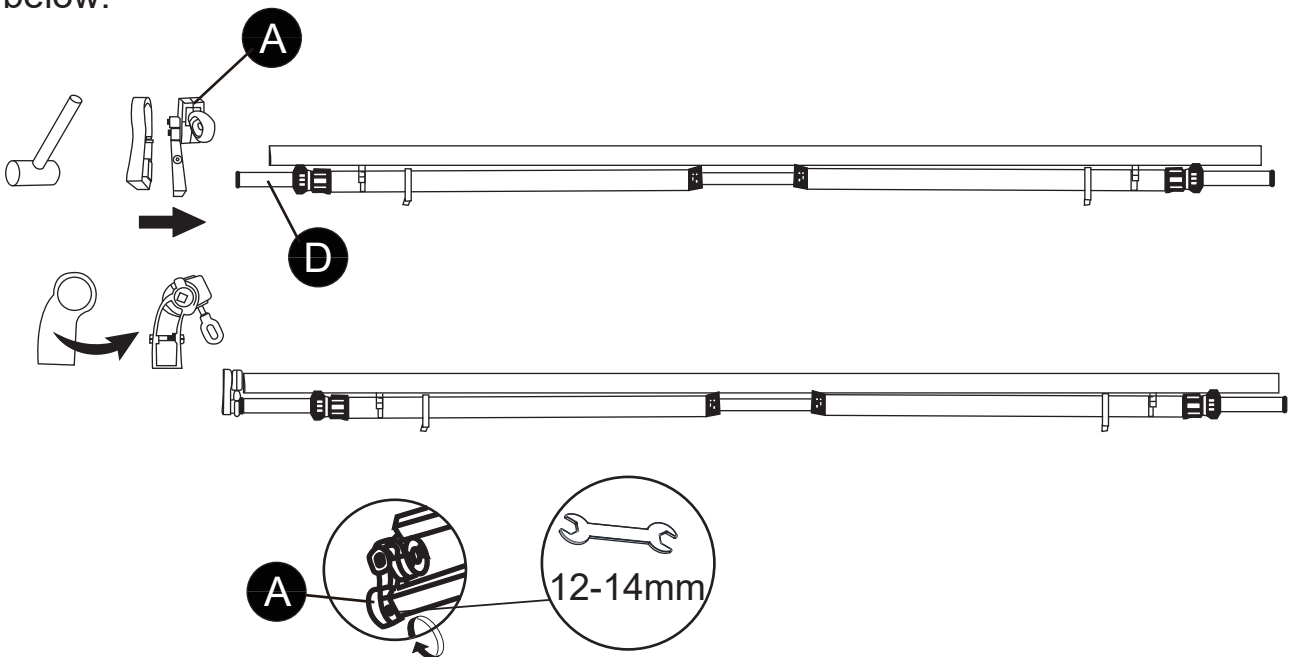

Step 8: Fabric and valance assembly

Open the fabric bag. Spread out both fabrics 14A and valance 14B and use the cloth guiding wire to line through the fabric. As shown in the figure below.

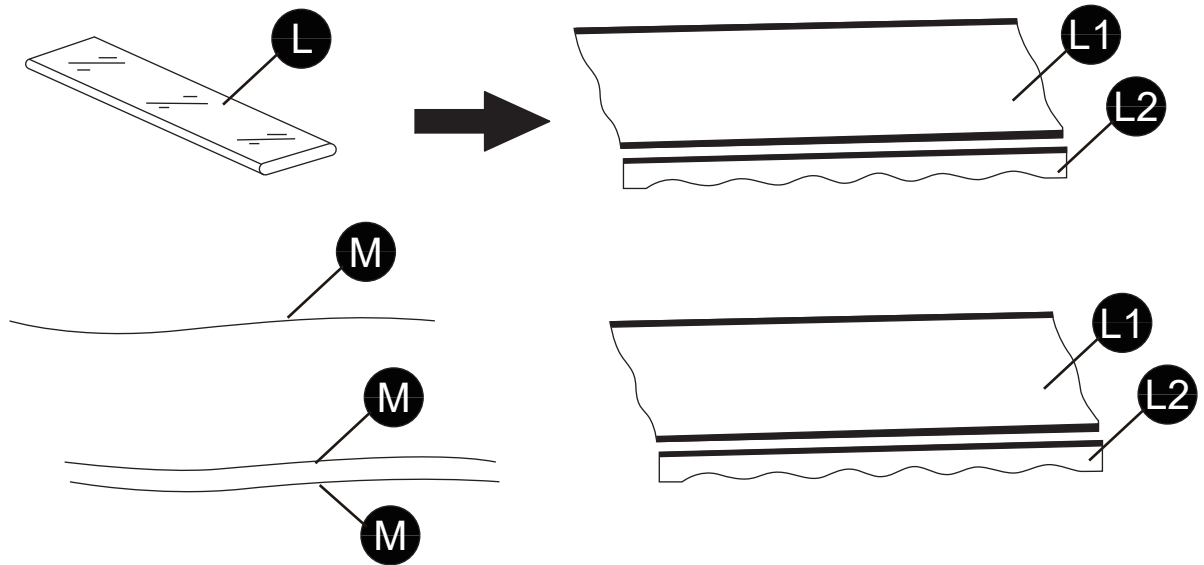

Step 9: Roll in the fabric on the roller

Roll in the fabric on the roller, pay attention to the fabric direction needed, as shown in the figure below:

Please face up the fabric when assembling. Keep the same space (X) at both ends.

Spread the fabric slowly to avoid damage.

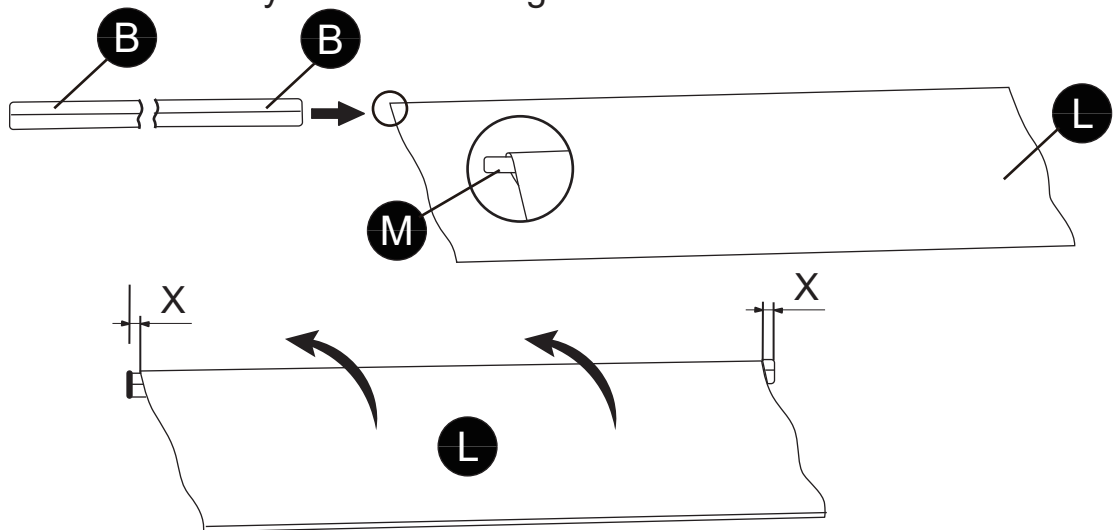

Step 10: Fabric installation

Insert one end of the fabric through the groove of the front bar and distribute the fabric evenly after pulling it all the way through. Then, insert the roll axle into the square hole of the gearbox housing, as shown in the figure below.

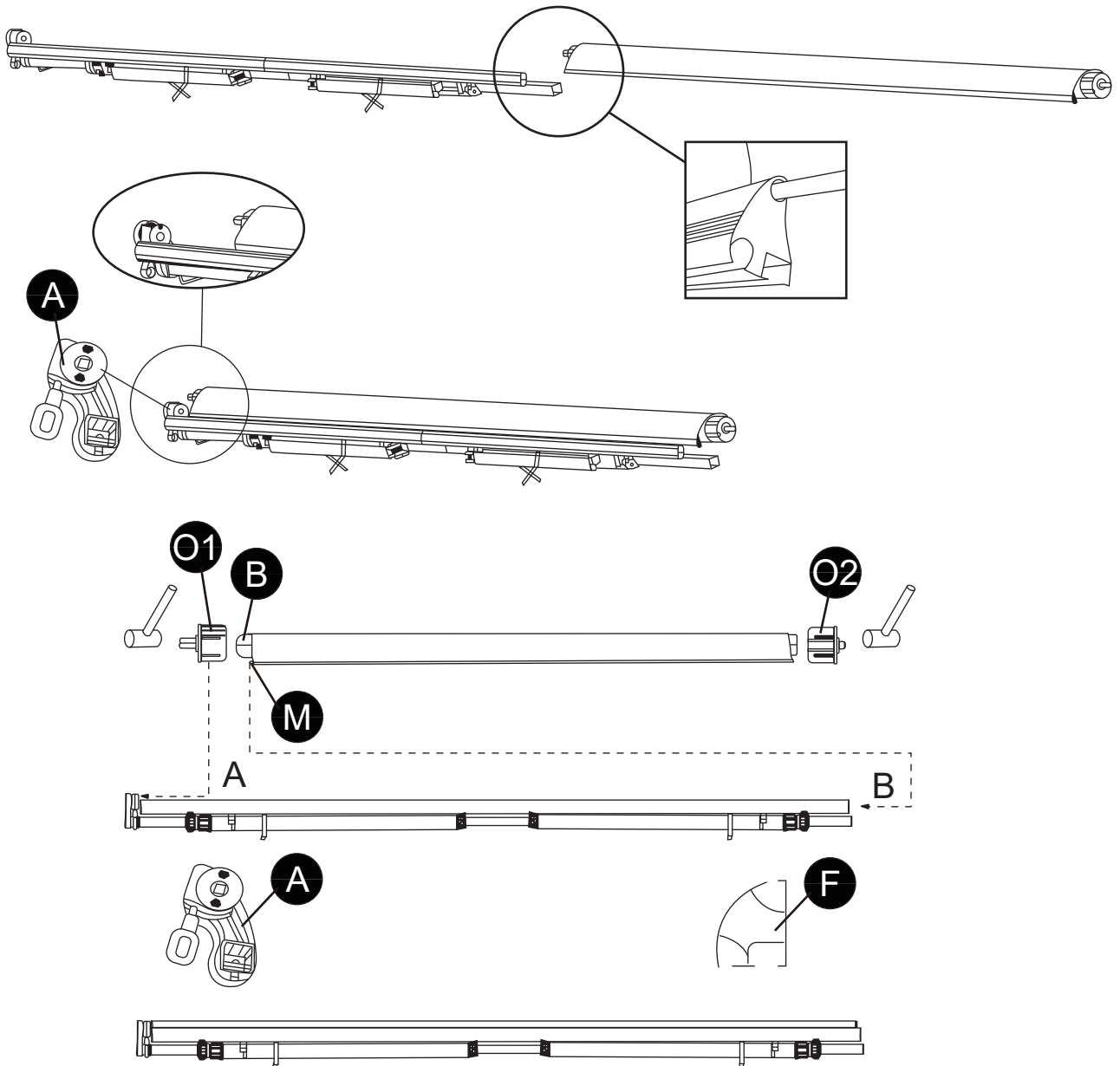

If the part of the front bar is a little deformed, please adjust it with tools by yourself.

Step 11: Right roller support assembly

Insert the roll axle into the roll tube cap while simultaneously guiding the support tube rod into the right roll bracket by tapping it in. Then, tighten the right hex screw with a 5 mm hexagon wrench, as shown in the figure below:

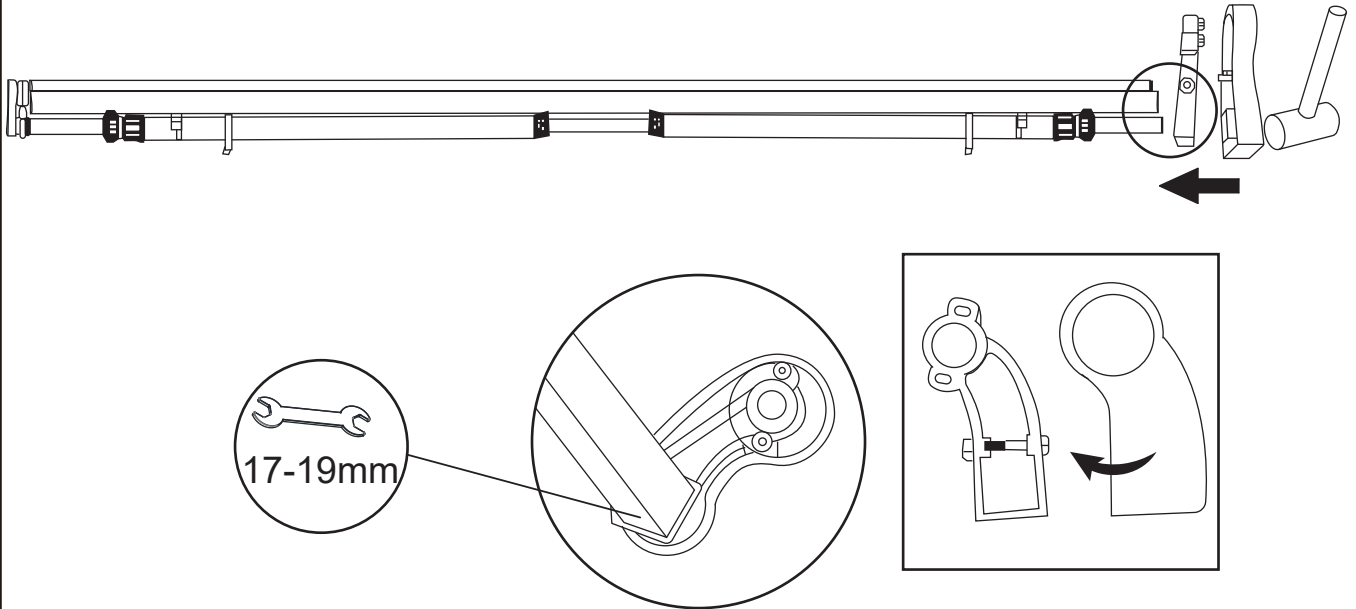

Step 12: Assemble to make a whole awning

Insert the valance through the groove of the front bar, ensuring the correct direction and even alignment on both the left and right sides. Then, use a hammer to attach the front bar cap to the end of the front bar, as shown in the figure below:

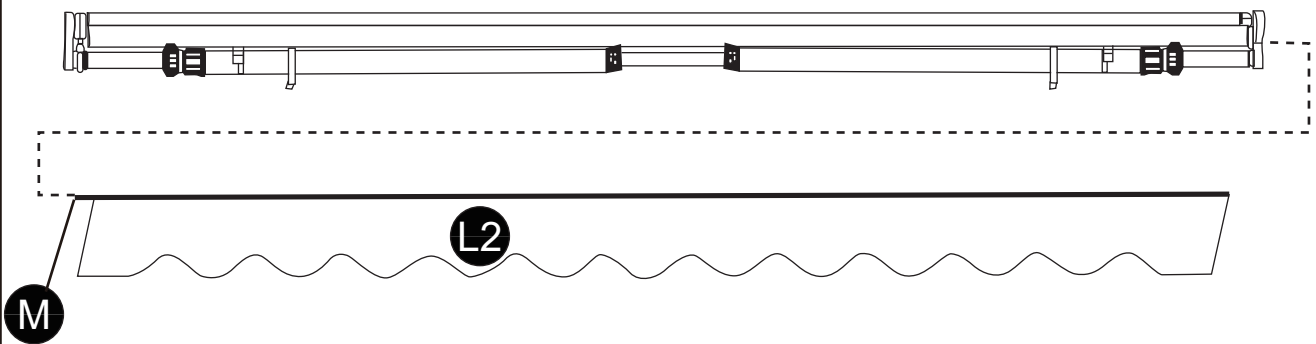

If the part of the front bar is a little deformed, please adjust it with tools by yourself.

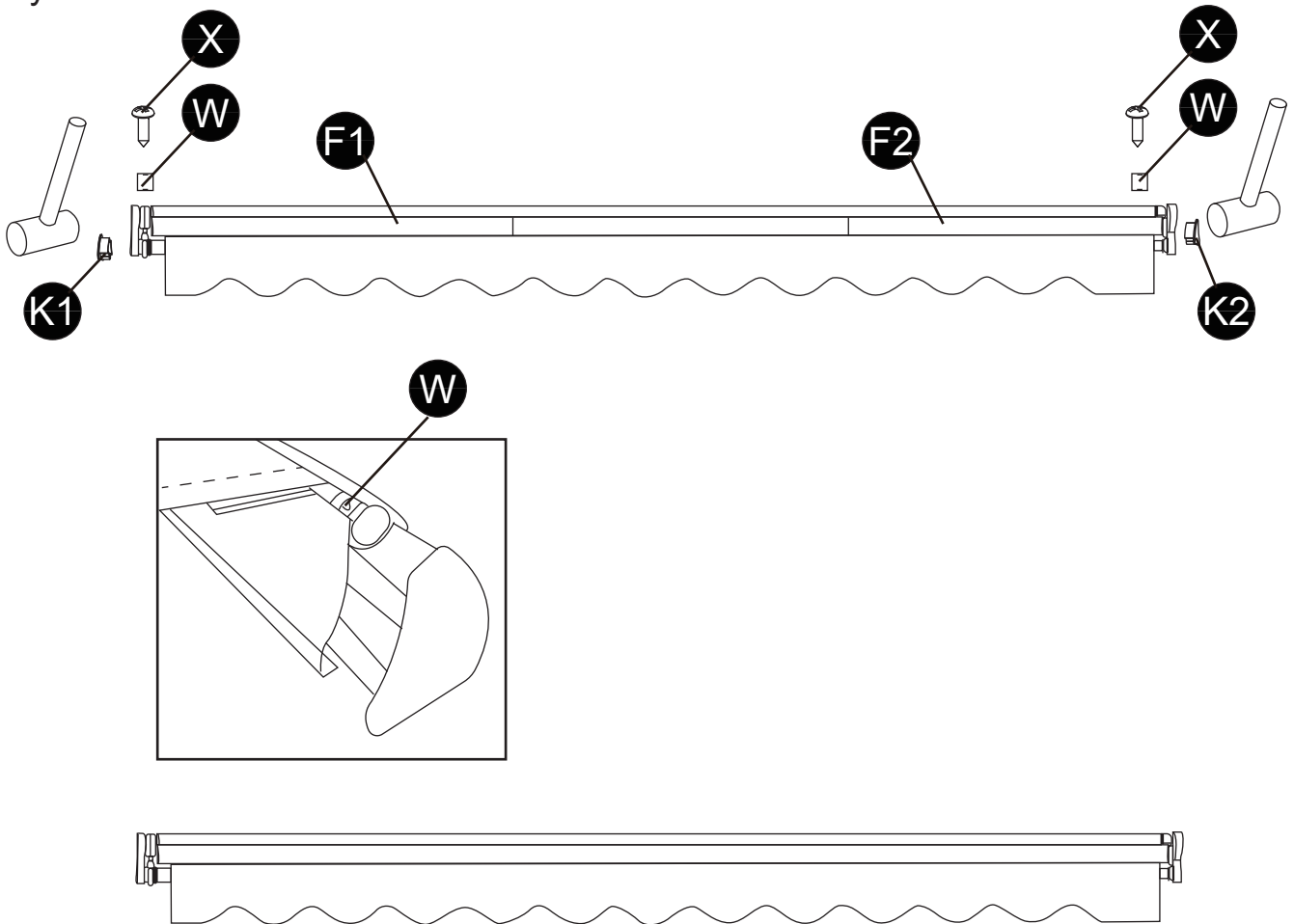

If you find that the fabric wraps unevenly or that the two arms won't open together at the same time, look at the stability of the two arms. Solution: Adjust the position of the arm bar connector on the front bar outward if necessary.

Specification



Product name	Retractable awning (Please see details on the package)
Material and surface treatment	<p>Materials: Steel tube, aluminum alloy, plastic parts, polyester fabric.</p> <p>Service treatment: Tubes: spray paint and oxidation</p> <p>Cloth surface: PU, UV, waterproof</p>
Applicable wall type	Reinforced concrete walls, brick walls, and wooden walls
Recommended Installation height	<p>2.5m-4m</p> <p>8'-13'</p>
Applicable weather	<p>The products are used to shield sunshine.</p> <p>Applicable when the wind is under level 5.</p> <p>Not suitable for rainy weather.</p>

Wall Mounting

Notes about Wall Mounting

This awning can be secured to reinforced concrete, brick and wood walls. However, this awning kit only supplies screws suitable for mounting to brick and reinforced concrete walls.

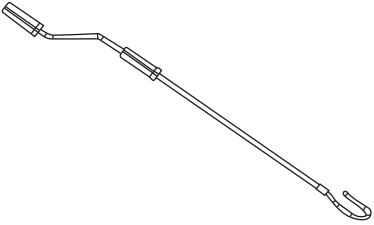
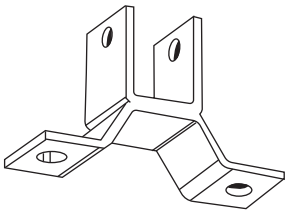
If you wish to secure your awning to wood, please use wood screws of adequate length and of an appropriate diameter to secure the awning to wood beams. The bolt size depends on the size of wood; these can be purchased at a hardware store. We recommend a professional installer for the safest and most secure installation. Never attempt to secure the wall brackets to loose wall stones or any surfaces that are not firm!

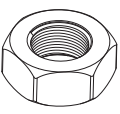
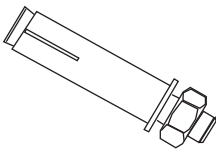
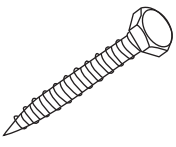
<p>I</p>  <p>1pc</p>	<p>J</p>  <p>2pcs</p>	<p>P2</p>  <p>M8x55</p> <p>2pcs</p>	
<p>Q</p>  <p>M8</p> <p>2pcs</p>	<p>V</p>  <p>M8</p> <p>2pcs</p>	<p>S</p>  <p>4pcs</p>	<p>Z</p>  <p>M10x72</p> <p>4pcs</p>

! CAUTION

The proper location of the brackets is the most important aspect of the awning installation. It is critical that you fasten all the mounting brackets to studs, joists, headers or other major structural components.

! WARNING

Failure to securely fasten all the brackets to the wall could result in the collapse of the awning and cause personal injury or death.

Mounting Height

It is important to take the awning's drop area into consideration before bolting your wall mounts. If you would like to mount above a patio door, for example, please leave at least 8" (20.5cm) above the door frame and be sure that the awning does not interfere with opening and closing the door. The drop angle can only be changed minimally, so take this into consideration when deciding where to place your awning.

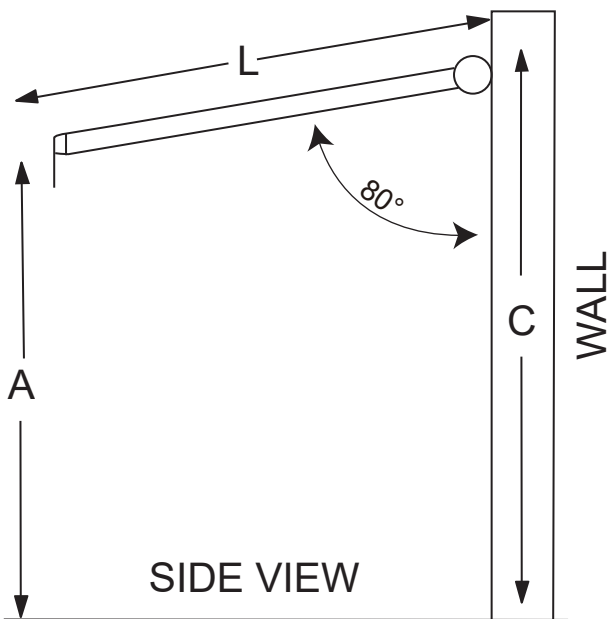

Recommended installation height:
8-13 '(2.5-4m). The ideal drop angle
(when fully extended) has already been
set in the factory, so you may not have to
change the pitch/angle.

CALCULATIONS:

You can use the following formula to
calculate the appropriate angle.

$$C = A + 0.17 * L$$

A = The desired height of the front bar
L = The length of the arm stretched out
C = The height of the wall brackets

We recommend that the awning surface make an angle of about 80 degrees to the wall when open.

STEP 1

Measuring the Mount Site

1. Measure the length of your awning along the wall where you intend to install it. This line will be the highest point of your awning and align with the top of the wall bracket. Use a leveler to make a chalk line across the distance.
2. Important: Double check that the line is level all the way across.
3. Be sure that the line is centered over the patio door, window, or other feature, if applicable.
4. Now that you have a straight, centered line, measure the middle point and mark it. This is where the middle wall bracket will be installed.
5. Take a wall bracket and place the top of it, completely level, under the line, as shown in the figure below. Mark the position of all wall brackets and their bolt holes with a chalk or a pencil. Please note the distance between each wall bracket should be the same.

Awning <10.8'(3.5m)	Requires only 2 wall brackets total: one for each end of the support tube rod.
Awning =10.8-14'(3.5-4m)	Requires 3 wall brackets total: one for each end, and one in the middle.

The distance between eaves and wall bracket 23.9"(10cm)

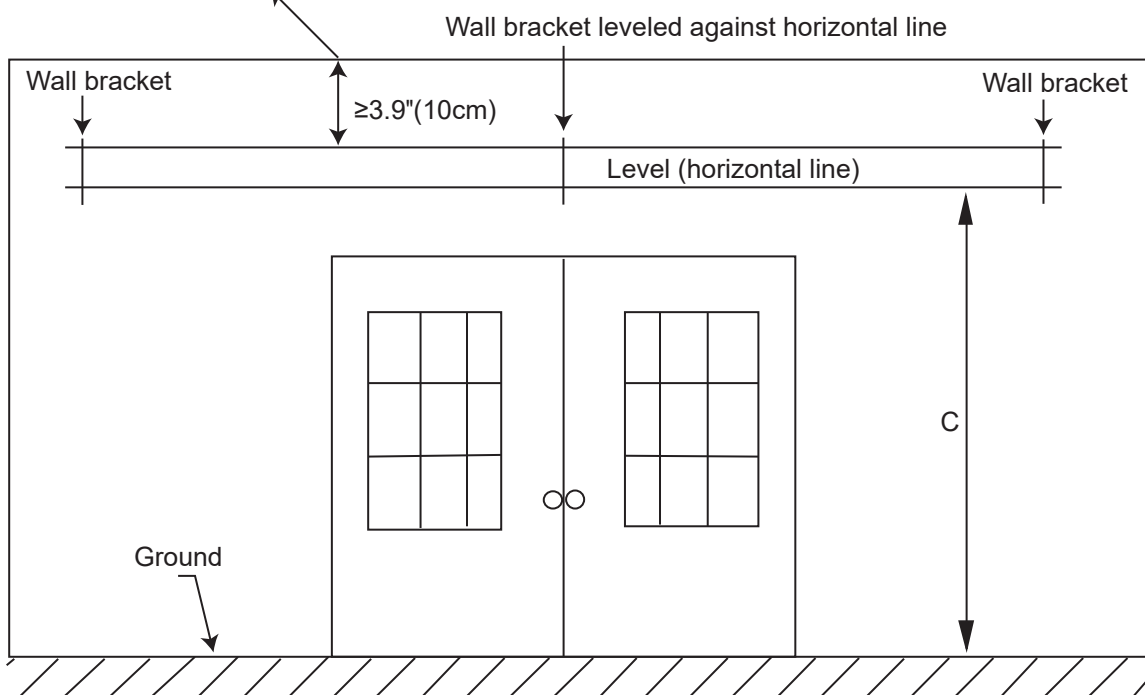

STEP 2

Drilling the bolt holes

1. Now that you have a straight level line across the wall with the locations of the wall brackets and their bolt holes marked, you can drill holes to mount the brackets.

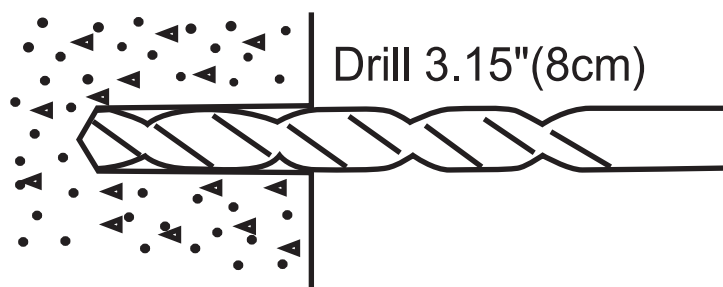

2. Using a 0.55\"(14mm) drill bit, drill the first bolt hole approximately 3.15\"(8 cm) deep, as shown in the figure. This must be drilled through solid brick or concrete to offer the necessary support for the awning.

3. Drill the remaining holes exactly as in step 2.

! WARNING

All bolt holes must be aligned vertically and horizontally to ensure that the awning hangs straight.

Double check alignment before drilling if you are not certain.

! WARNING

The diameter and depth of your mounting holes must be the same size as the expansion bolts.

STEP3

Preparing for Mounting

1. Now that all of your holes are drilled, insert the expansion bolts.
2. It may be necessary to drive the bolts in with a wooden (or other non-metallic) mallet.



If a mallet is necessary for installation, we recommend placing the nut on the screw (loosely) before hammering to avoid damaging the bolt threads.

3. Make sure that the bolts are firm in place yet let them stick out of the wall approximately 1 inch (2,5cm) or less—enough that the wall bracket can be installed onto them.

Firmly tighten the bolts with a 0.75" (19mm) hex key. It is best to use the hex key with a closed end rather than an open end to avoid damaging the nut, should it slip.

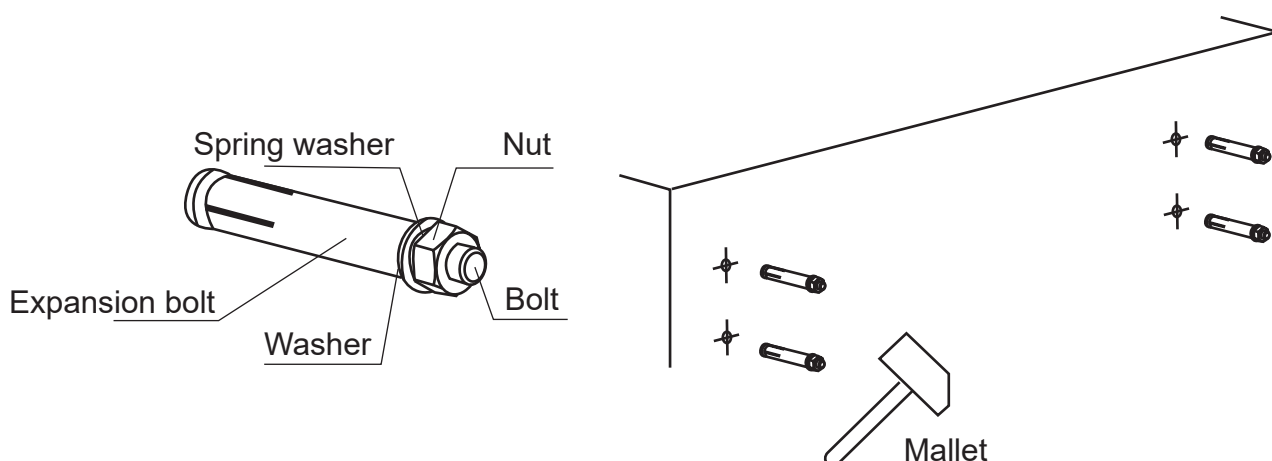

STEP4

Mounting the Wall Brackets

1. Now that the bolts are securely installed on the wall, remove the nuts that are loosely placed over the bolts.
2. Place a wall bracket onto one set of bolts. This should be an easy fit if the bolt holes are properly aligned.
3. Once the wall bracket is resting on the bolts, place a washer over the bolt. Then secure it with a nut, as shown in the figure.

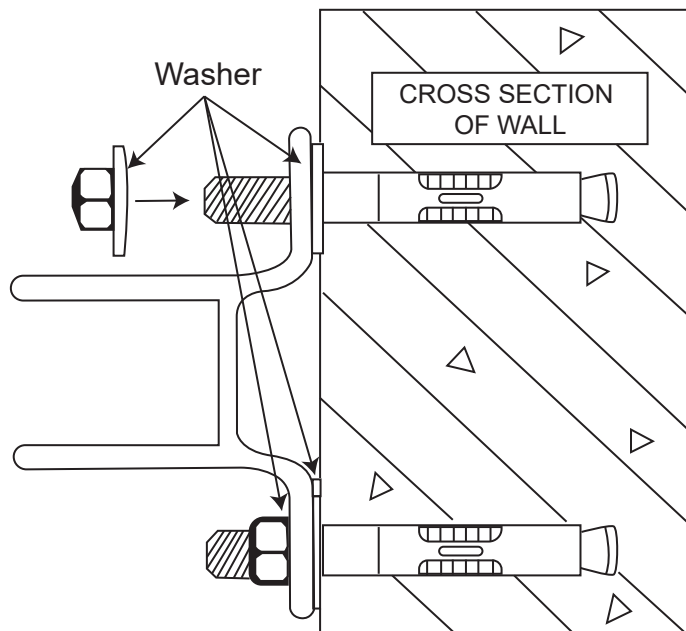

4. The brackets **MUST** sit firmly on the wall. If there is any movement, you must tighten it more.
5. Repeat this step for each of the wall brackets. Once you do this, all wall brackets will be securely installed in place.

STEP5

Mounting the Awning

1. Now that the wall brackets are secure and in place, it is time to install the awning onto the brackets.
2. Put the support tube rod on the wall brackets and tighten them with the hex screws.
3. Finally, fasten all expansion bolts.
4. Using the hand crank or a motor (if applicable), fully open your awning. The front bar should be level.
5. Congratulations! Your awning is installed. If you are happy with the height of the front bar (awning pitch), sit back and enjoy! If not, please read on.

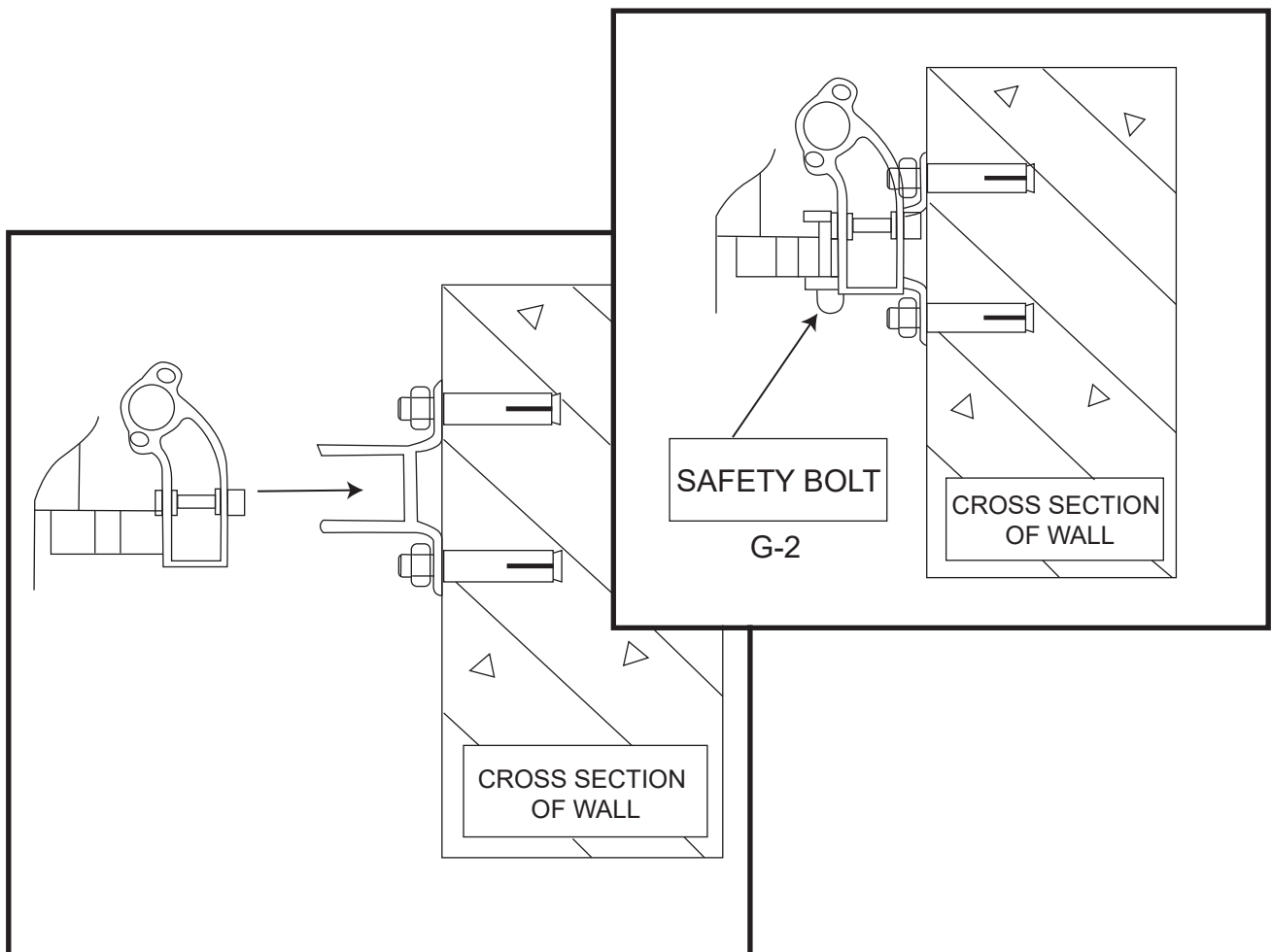

OPTIONAL INSTALLATION

Adjusting the Awning

Each awning comes with a pre-set angle that is considered ideal. However, if you need to make an adjustment, it can be done in just a few easy steps.

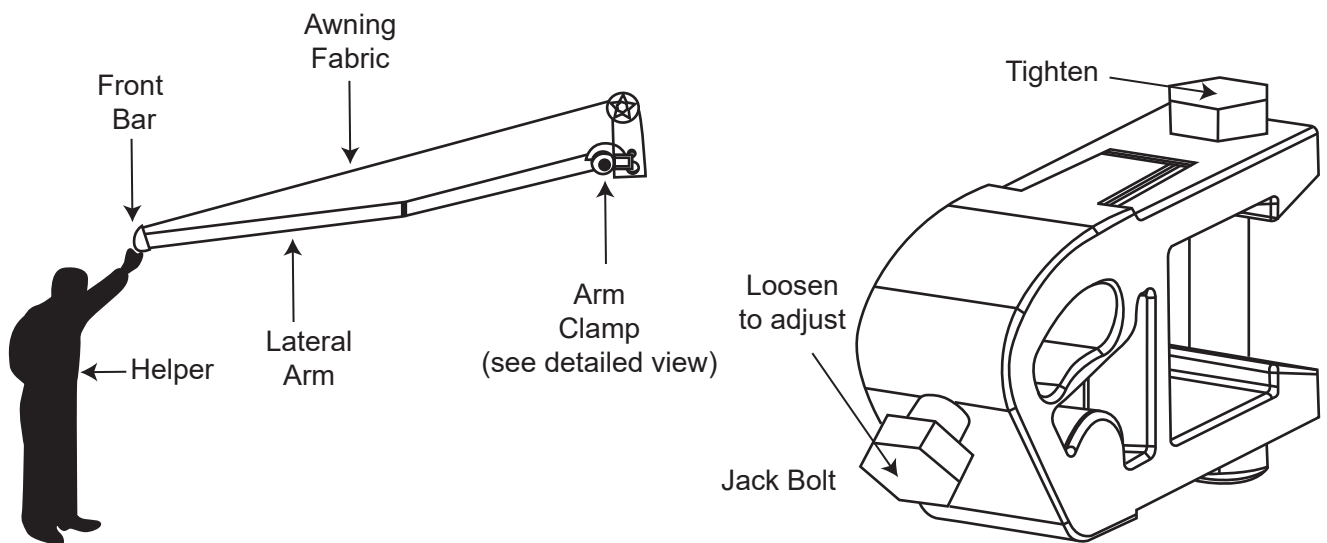

⚠ WARNING

Raising the front bar will reduce the angle of the fabric, thus increasing the risk of rainwater pooling on the fabric. To prevent the awning from collapsing due to rainwater weight, you must retract the awning when unattended. Failure to do so could result in a broken awning or personal injury.

Note: Be sure that the front bar is adjusted to be completely even. Any misalignment will result in improper retraction.

COMMON MISTAKES

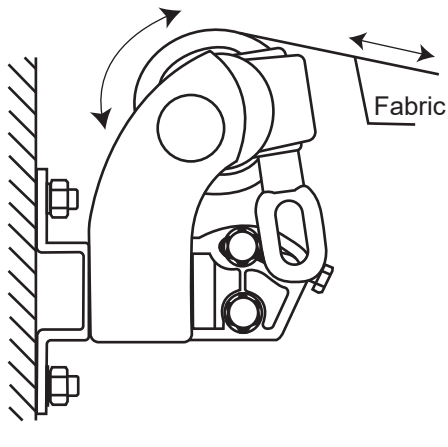

Correct operation

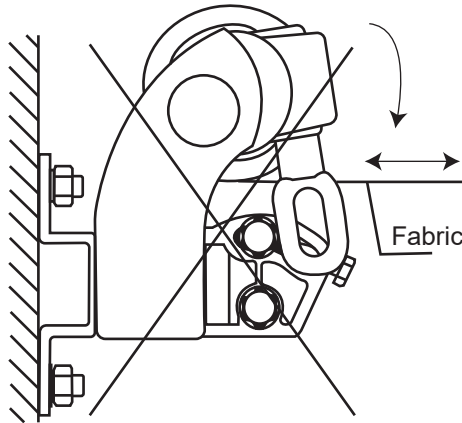

Wrong operation

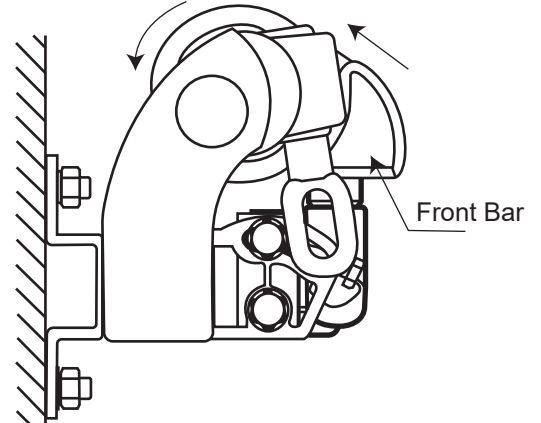

WARNING

When the front bar touches the roller as shown in the figure, don't try to make them closer, otherwise the product may be damaged.

Contact person
tectake Ltd
18 Soho Square
London W1D 3QL
United Kingdom
Telephone: +44 203 488 4565
www.tectake.co.uk
mail@tectake.co.uk

Markisen-Montageanleitung

3x2.5M 2.5x2M

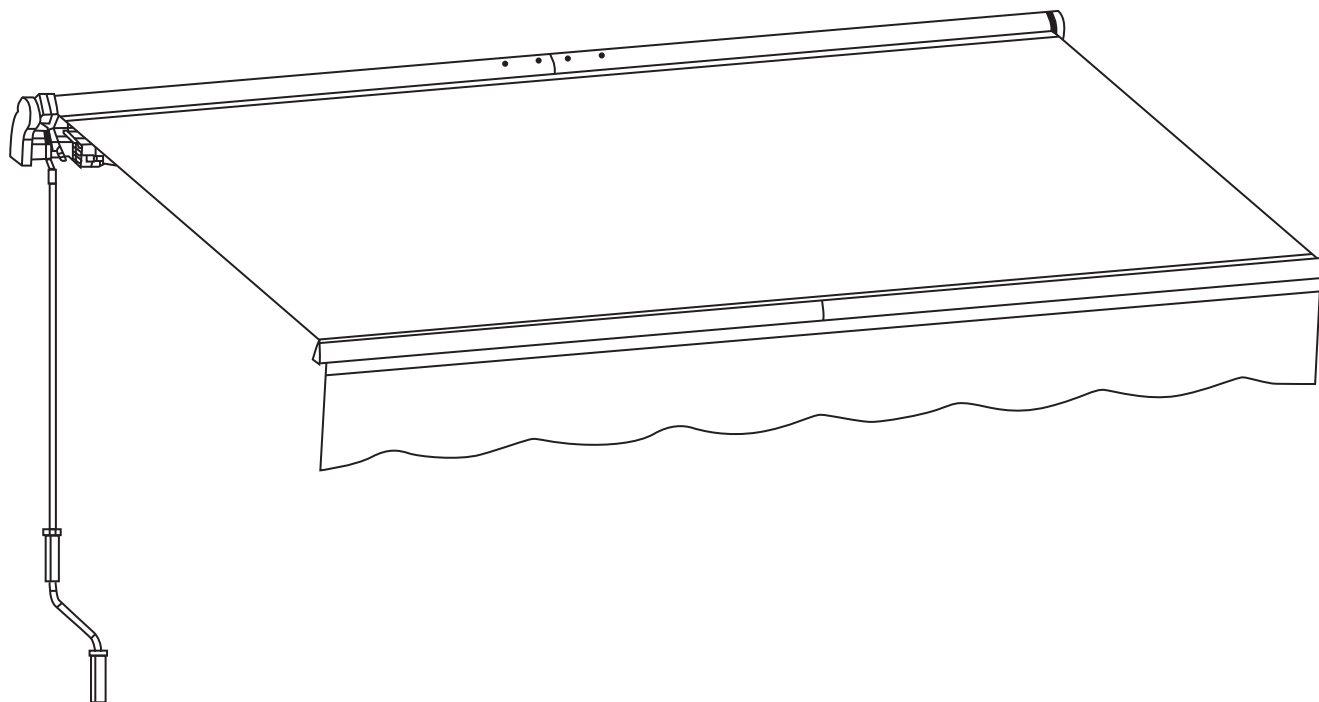

Vielen Dank, dass Sie unsere ausziehbare Markise gekauft haben! Wir hoffen, dass Sie viele Jahre Freude an unserem Produkt haben werden.







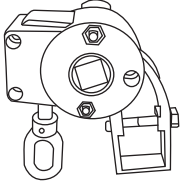
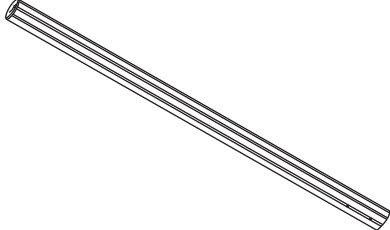
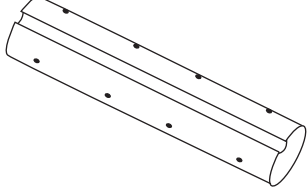
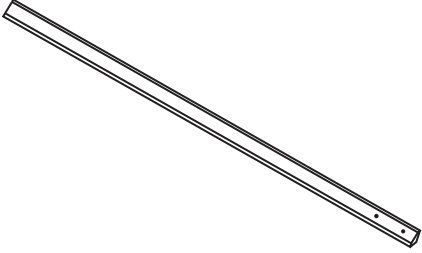
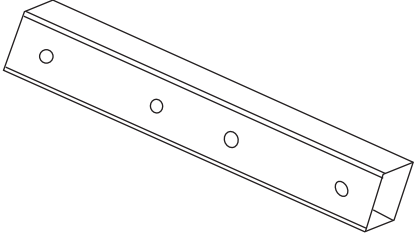
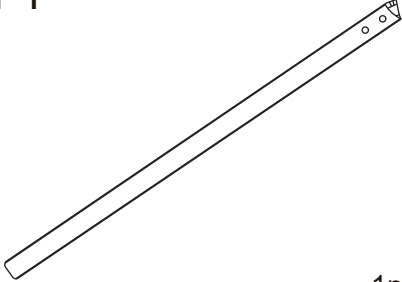
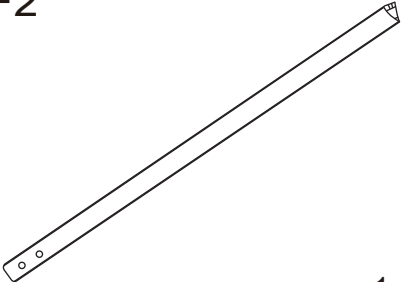
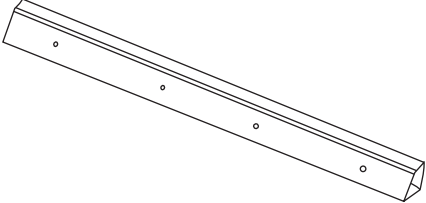
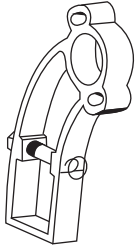
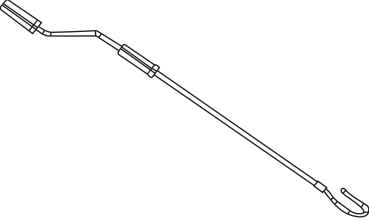
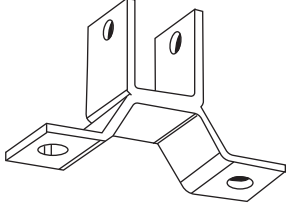
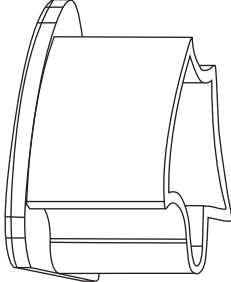
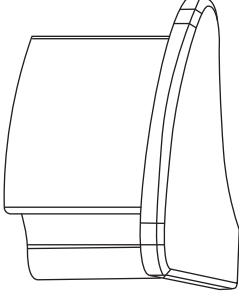
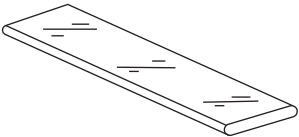
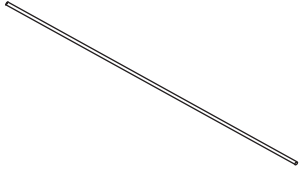

Um Ihre persönliche Sicherheit bei der Installation zu gewährleisten und das Beste aus Ihrer Investition herauszuholen, lesen Sie bitte dieses gesamte Handbuch, bevor Sie mit der Montage beginnen.

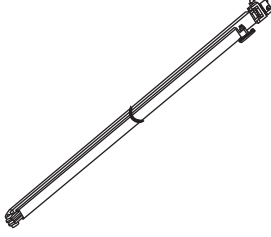
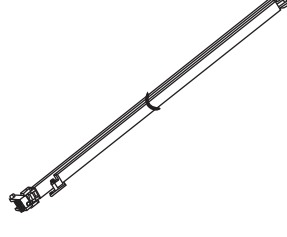
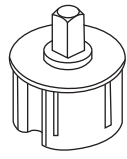
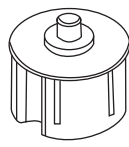
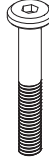
Wir empfehlen, diese Markise mit zwei Personen zu installieren. Falls Sie den Vorgang allein als zu schwierig empfinden, raten wir Ihnen, sich Hilfe von einem lokalen Bau- oder Heimwerkerunternehmen zu holen.

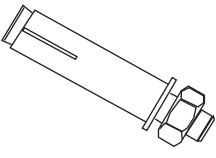

Bitte kontaktieren Sie unsere Kundenhotline, wenn Sie Probleme bei der Montage haben, Teile fehlen oder defekt sind oder andere Schwierigkeiten auftreten. Wir werden unser Bestes tun, um Ihnen zu helfen.

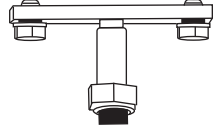
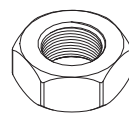

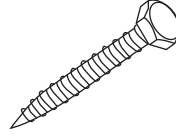
**Teileliste:
Optionale Installation**

<p>A</p>  <p>1pc</p>	<p>B</p>  <p>2pcs</p>	<p>C</p>  <p>1pc</p>
<p>D</p>  <p>2pcs</p>	<p>E</p>  <p>1pc</p>	<p>F1</p>  <p>1pc</p>
<p>F2</p>  <p>1pc</p>	<p>G</p>  <p>1pc</p>	<p>H</p>  <p>1pc</p>
<p>I</p>  <p>1pc</p>	<p>J</p>  <p>2pcs</p>	<p>K1</p>  <p>1pc</p>
<p>K2</p>  <p>1pc</p>	<p>L</p>  <p>1pc</p>	<p>M</p>  <p>3pcs</p>

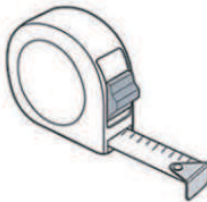
<p>N1</p>  <p>1pc</p>	<p>N2</p>  <p>1pc</p>	<p>O1</p>  <p>1pc</p>	
<p>O2</p>  <p>1pc</p>	<p>P1</p>  <p>M6x40</p> <p>4pcs</p>	<p>P2</p>  <p>M8x55</p> <p>2pcs</p>	<p>Q</p>  <p>M8</p> <p>2pcs</p>
<p>R</p>  <p>M6</p> <p>4pcs</p>	<p>S</p>  <p>4pcs</p>	<p>T</p>  <p>M5x16</p> <p>16pcs</p>	<p>U</p>  <p>2pcs</p>
<p>V</p>  <p>M8</p> <p>2pcs</p>	<p>W</p>  <p>2pcs</p>	<p>X</p>  <p>M3x10</p> <p>2pcs</p>	<p>Z</p>  <p>M10x72</p> <p>4pcs</p>

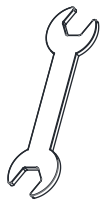
Bitte bereiten Sie vor der Montage die folgenden, nicht im Lieferumfang enthaltenen Werkzeuge vor:

<p>Maßband</p>	<p>Kunststoff/Gummihammer</p>	<p>Gabelschlüssel (M17 und M14)</p>
		

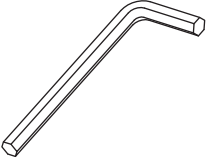
Kreuzschlitzschraubendreher	Bohrmaschine mit 14mm-Bohrer	Nivelliergerät oder Wasserwaage	8-mm-Gabelschlüssel
			

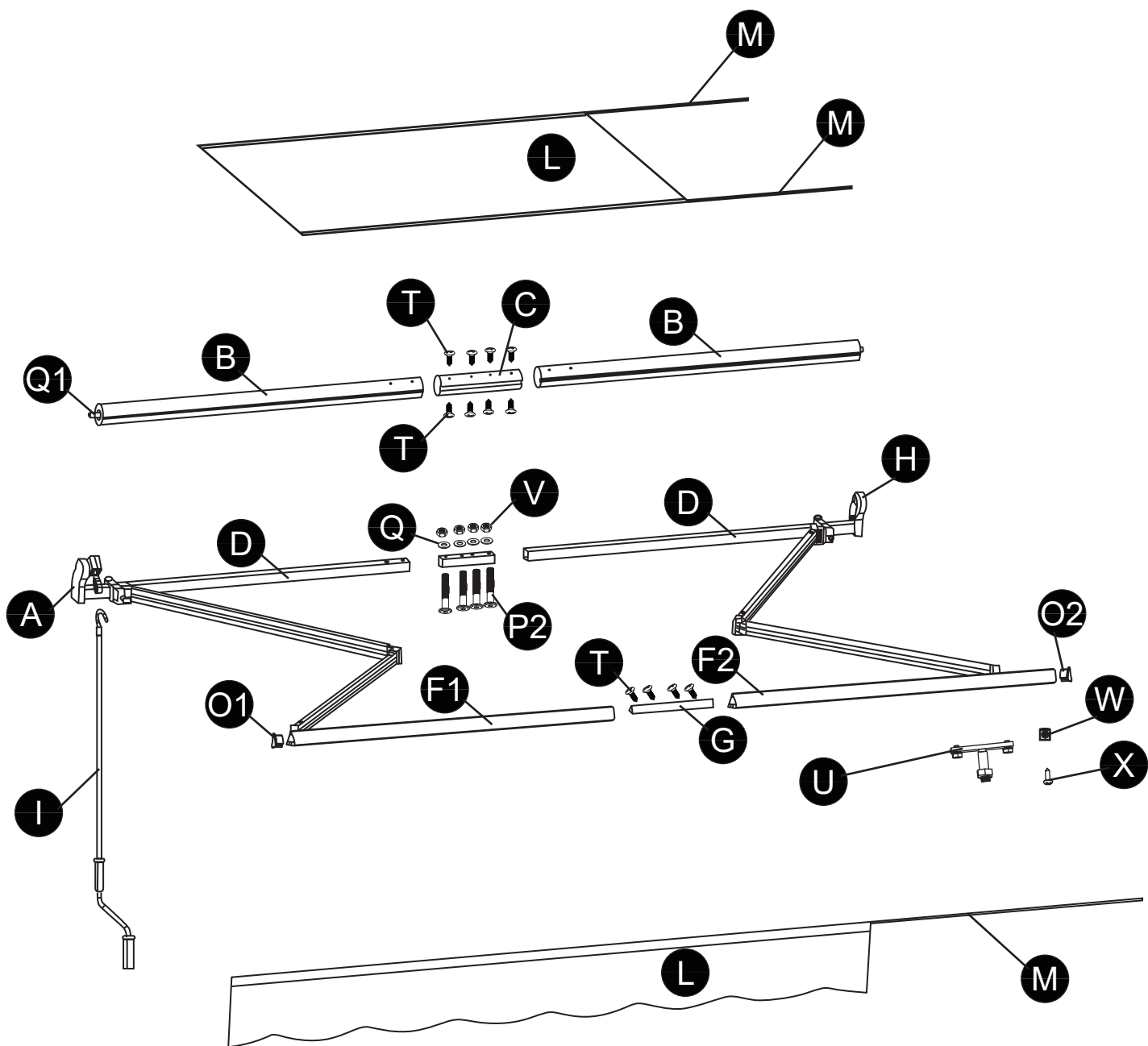

Vorbereitung des Arbeitsbereichs

1. Bevor Sie beginnen, legen Sie alle benötigten Werkzeuge bereit. Eine Liste finden Sie im Abschnitt "Erforderliche Werkzeuge".

WARNUNG

Entfernen Sie NICHT die Sicherheitsbänder, die die Markisenarme fixieren. Das vorzeitige Entfernen kann zu schweren Verletzungen führen.

2. Öffnen Sie die Markisenverpackung und entnehmen Sie alle Teile vorsichtig, um Schäden zu vermeiden.
3. Legen Sie alle Markisenteile aus, um sicherzustellen, dass keine fehlen. Weitere Details finden Sie im Teile-Diagramm.
4. Öffnen Sie die kleine Innenverpackung mit den Kleinteilen und legen Sie diese ebenfalls bereit.

Montage:

Schritt 1: Montage der Wickelwelle

Halten Sie die Wickelwellen ausgerichtet, befestigen Sie sie mit den Verbindungsstücken und sichern Sie sie mit den entsprechenden Schrauben gemäß der Abbildung unten.

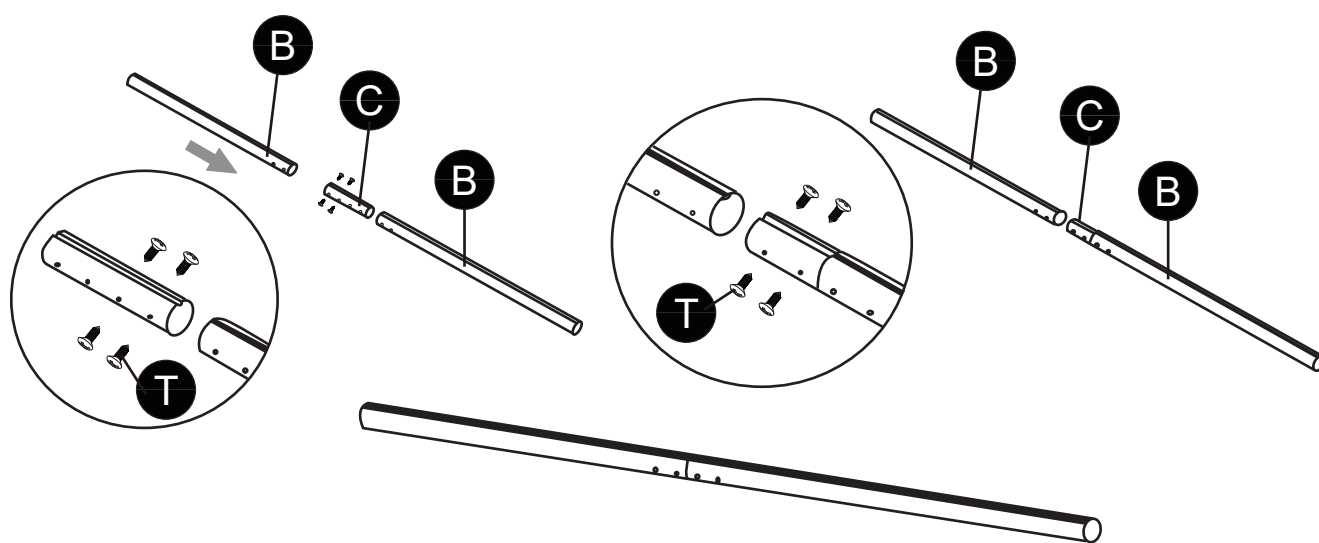

Schritt 2: Montage der Tragrohrstäbe und Arme

Richten Sie die vier Seiten aus, verbinden Sie die Tragrohrstäbe mit den Verbindungsstücken und sichern Sie diese mit den entsprechenden Schrauben gemäß der Abbildung unten.

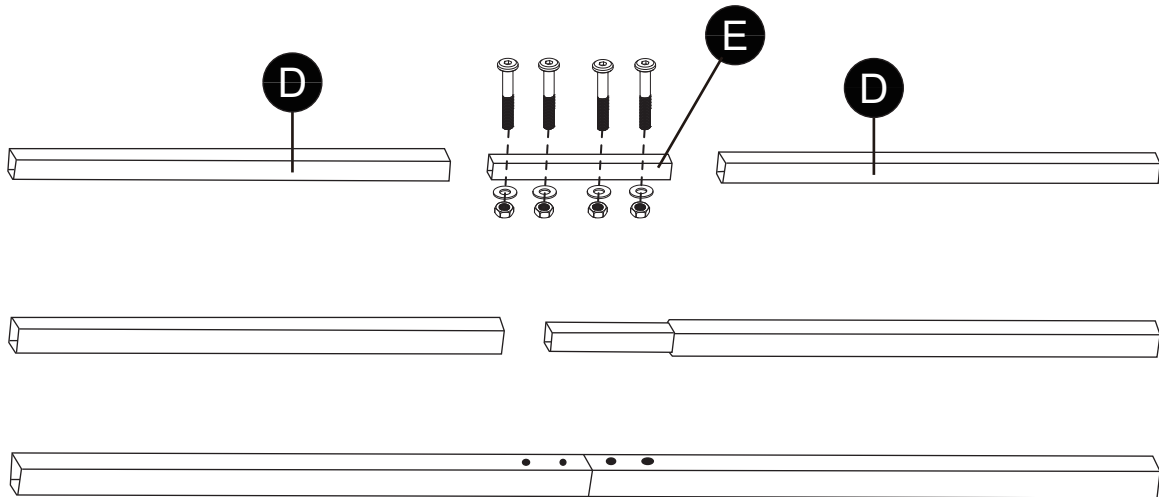

Befestigen Sie dann die Arme an den Tragrohrstäben. Die beiden Arme müssen in die gleiche Richtung zeigen. Das Seil der Arme kann erst entriegelt werden, wenn die gesamte Montage abgeschlossen ist.

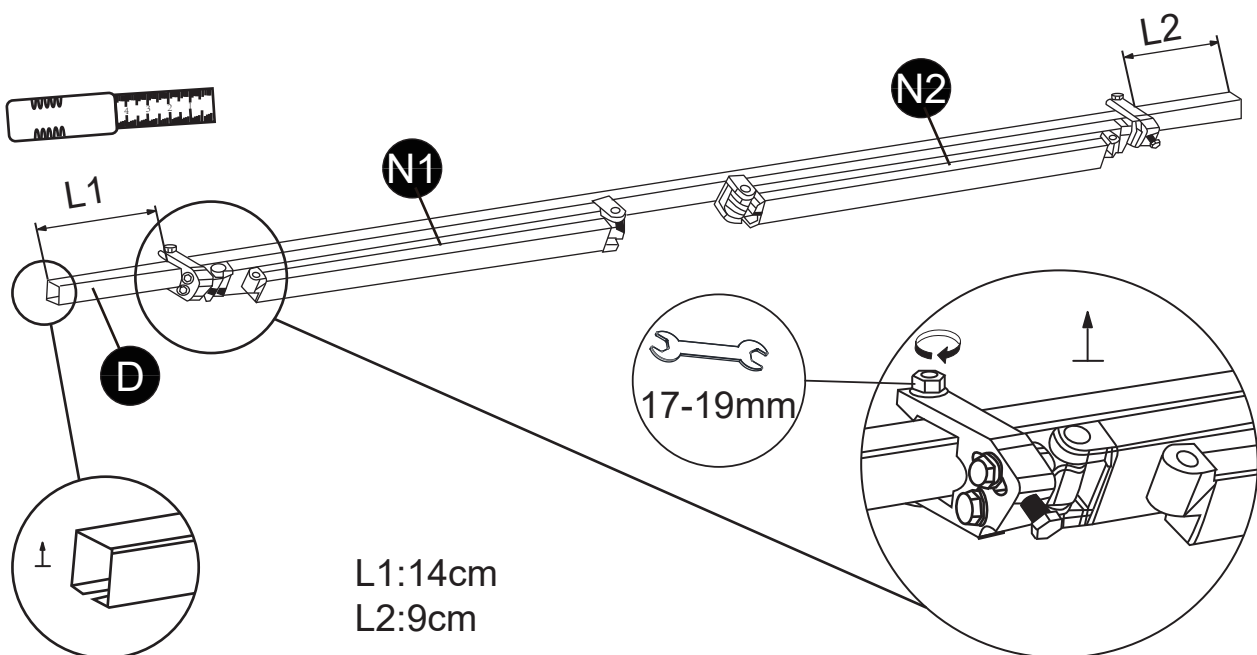

Schritt 3: Montage der vorderen Stange

Verbinden Sie die vordere Stange mit den Verbindungsstücken (Pos. 7) und sichern Sie sie mit den entsprechenden Schrauben gemäß der Abbildung unten. Achten Sie darauf, dass die vordere Stange gerade bleibt.

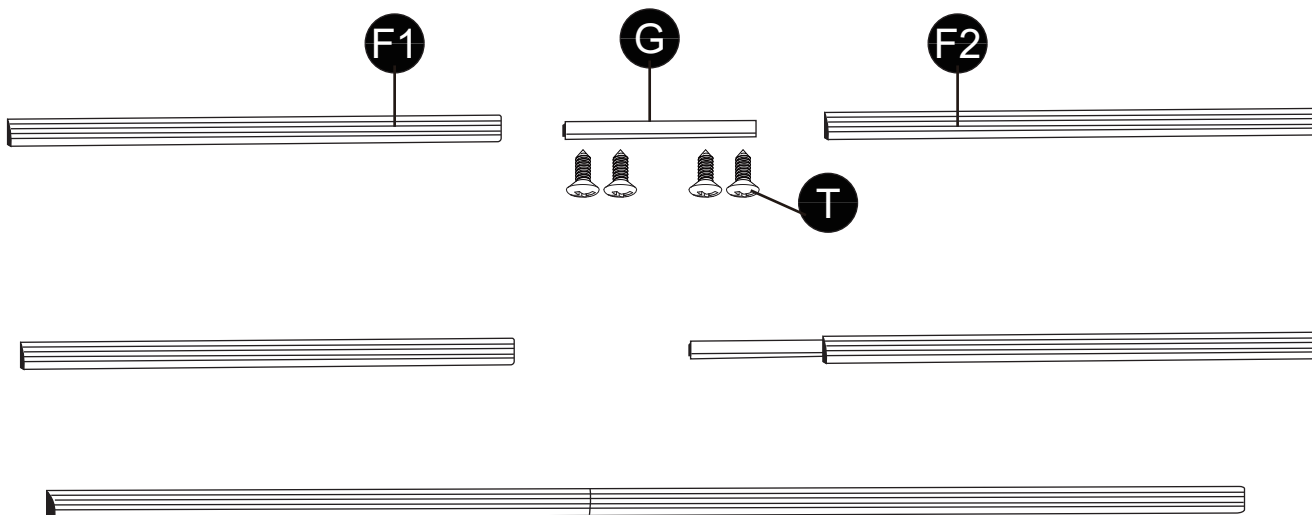

Schritt 4: Montage der vorderen Stangenhalterung

Schieben Sie die Füße (Pos. 18) in die Stange gemäß der Abbildung unten., ohne sie festzuziehen.



Schritt 5: Verbindung der Arme mit der vorderen Stange

Führen Sie die Gewindebolzen der Füße (Pos. 18) durch das Loch im kleinen Arm und positionieren Sie die vordere Stange. Ziehen Sie anschließend die Mutter mit einem Gabelschlüssel gemäß der Abbildung unten fest.

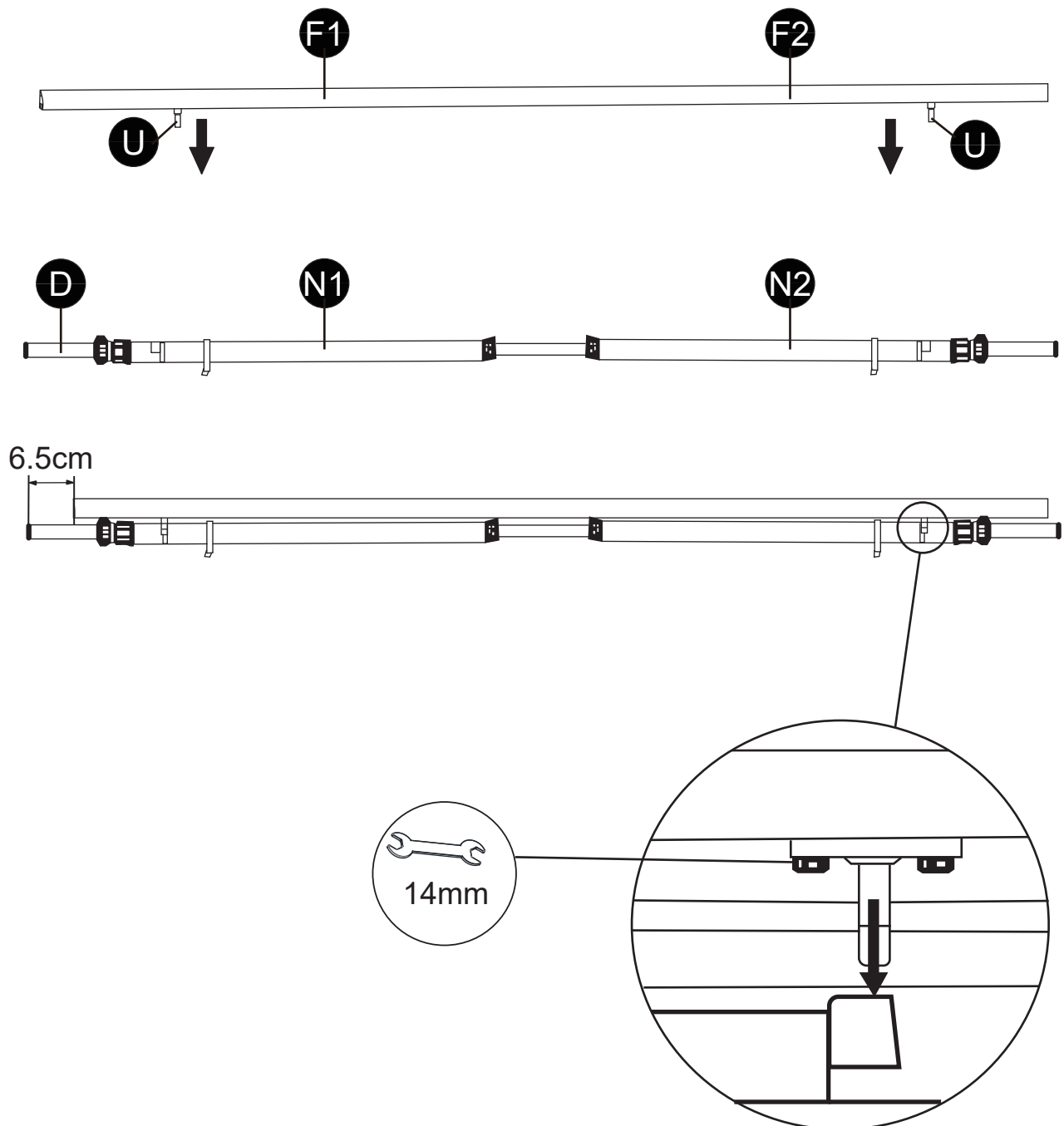

Schritt 6: Befestigung der selbstsichernden Mutter

Setzen Sie die selbstsichernden Muttern auf die Schrauben am unteren Ende der FüÙe und ziehen Sie sie mit einem Gabelschlüssel fest an (siehe der Abbildung unten).

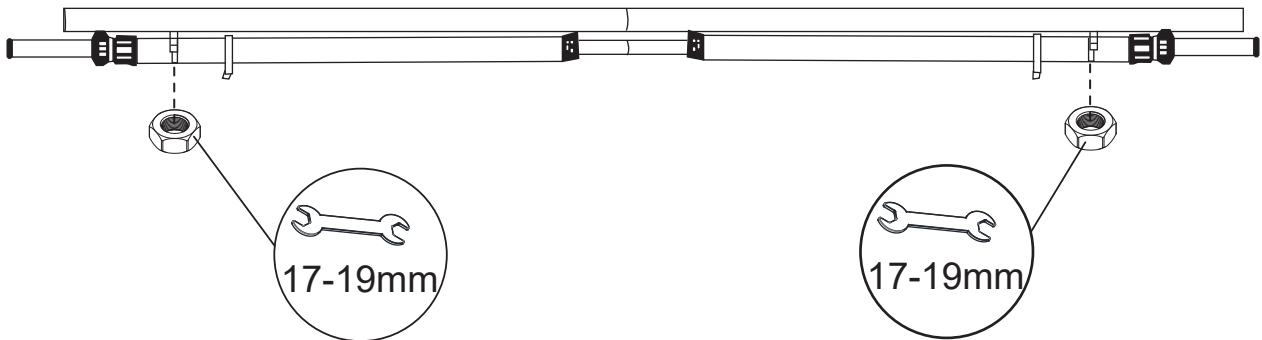

Achtung: Vor dem Festziehen der Muttern sicherstellen, dass die Arme korrekt ausgerichtet sind.

Schritt 7: Linke Rollenhalterung mit Getriebe montieren

Schlagen Sie die linke Rollenhalterung mit Getriebe mithilfe eines Hammers in das linke Ende des Tragrohrstabs ein. Anschließend ziehen Sie die linke Sechskantschraube, gemäß der Abbildung unten fest.

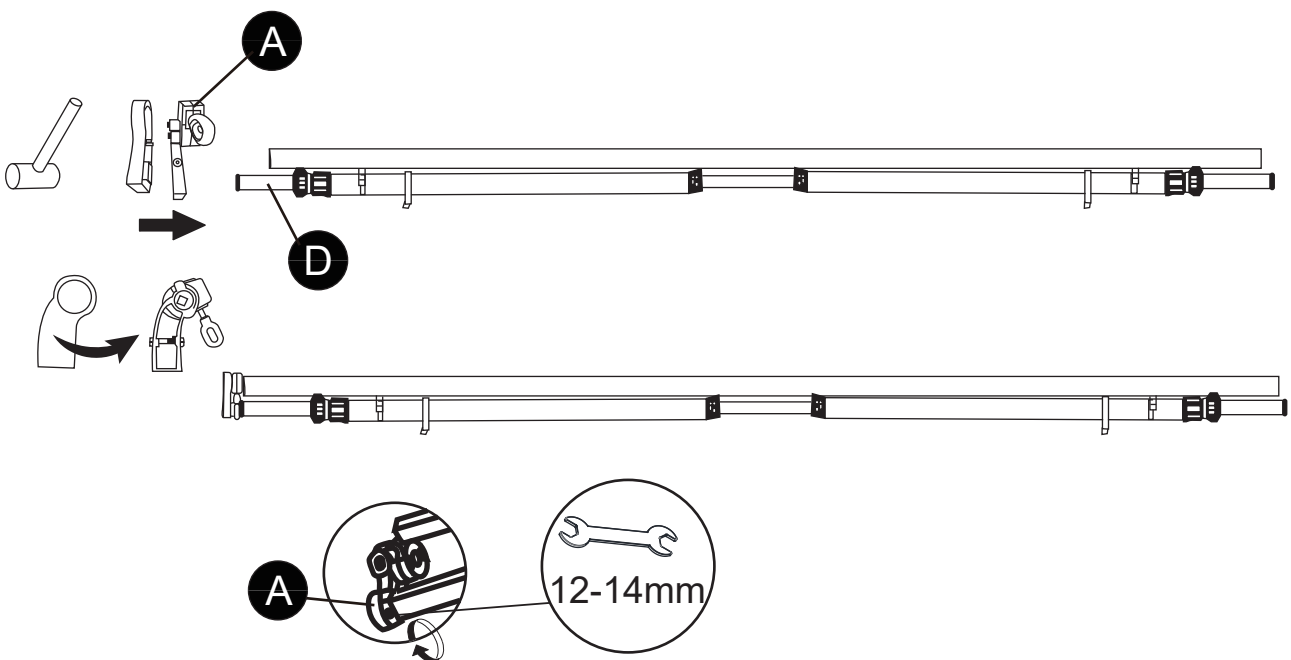

Schritt 8: Montage von Stoff und Volant

Öffnen Sie den Stoffbeutel. Breiten Sie beide Stoffe (14A) sowie den Volant (14B) aus und führen Sie den Stoff mit der Stoffführungsleine gemäß der Abbildung unten ein.

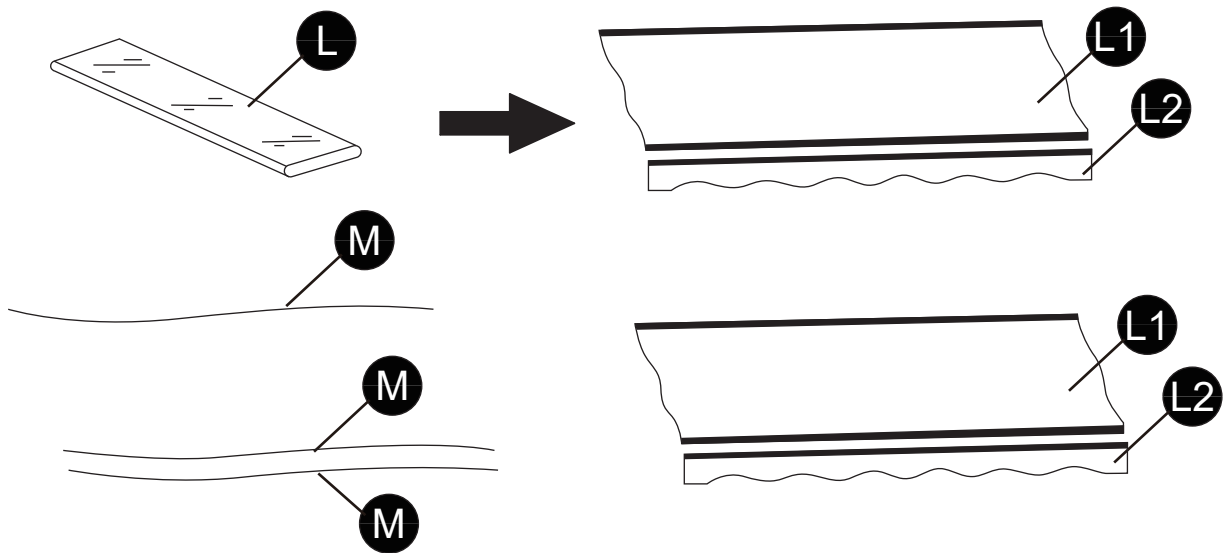

Schritt 9: Stoff auf der Rolle aufwickeln

Wickeln Sie den Stoff auf der Rolle auf und achten Sie auf die richtige Stoffrichtung, wie in der Abbildung unten gezeigt:
Achten Sie darauf, den Stoff beim Zusammenbauen mit der Oberseite nach oben zu platzieren. Halten Sie an beiden Enden den gleichen Abstand (X). Breiten Sie den Stoff langsam aus, um Beschädigungen zu vermeiden.

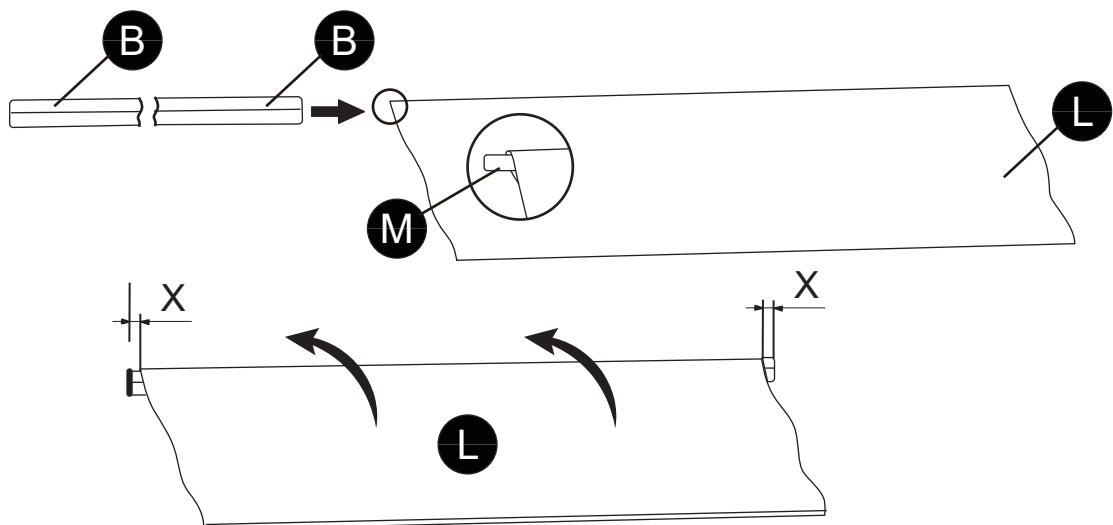

Schritt 10: Stoffinstallation

Führen Sie ein Ende des Stoffs durch die Nut der Frontstange, verteilen Sie den Stoff gleichmäßig, nachdem Sie den gesamten Stoff eingezogen haben. Setzen Sie dann die Achse der Rolle in das quadratische Loch des Getriegehäuses ein wie in der Abbildung unten gezeigt:

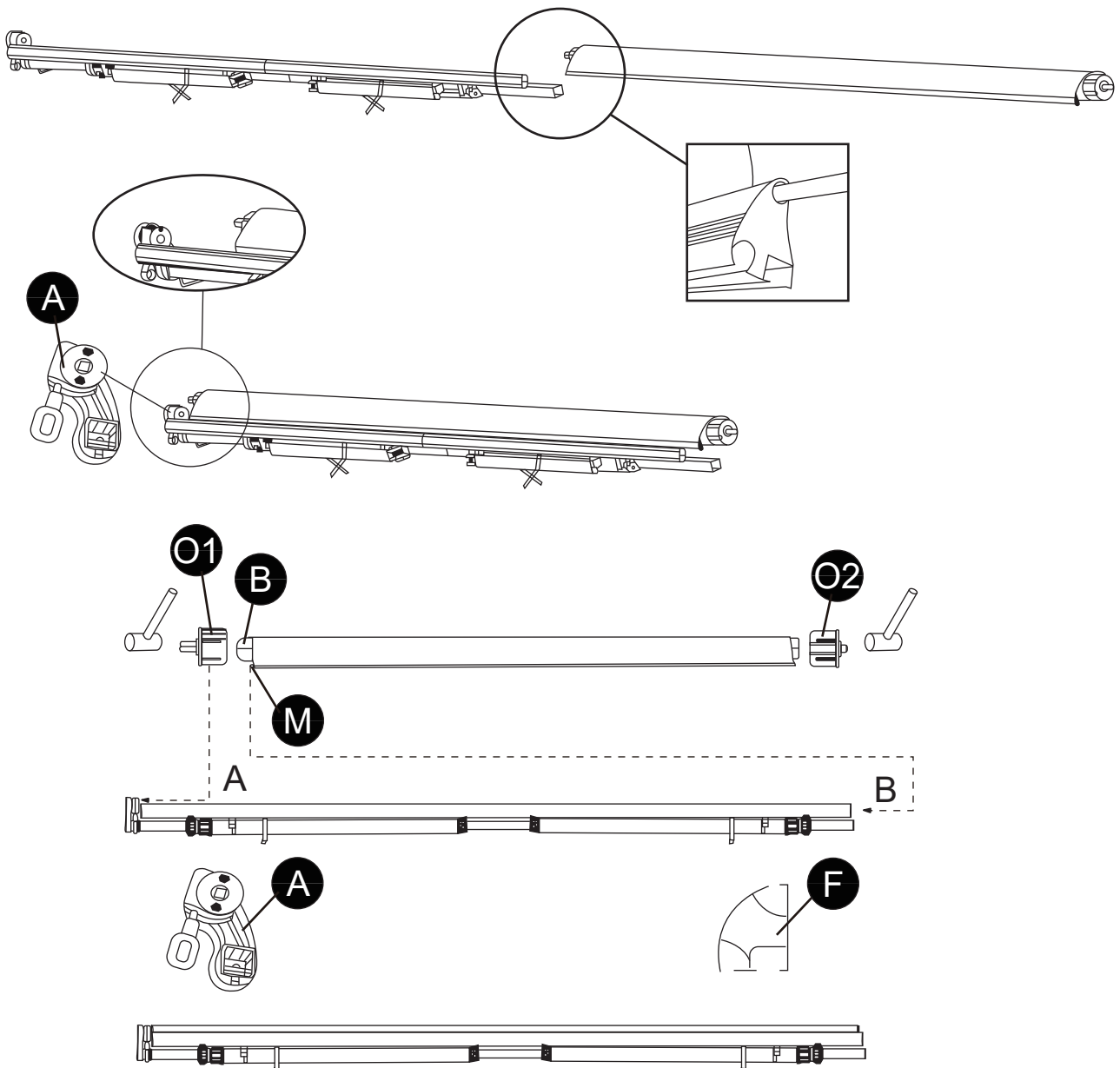

Falls der Teil der Frontstange leicht verformt ist, passen Sie ihn bitte bei Bedarf mit Werkzeugen selbst an.

Schritt 11: Montage der rechten Rollenhalterung

Setzen Sie die Achse der Rolle in den Rollrohrstopfen ein und führen Sie gleichzeitig den Tragrohrstab in die rechte Rollenhalterung ein, indem Sie sie ihn einschlagen. Ziehen Sie dann die rechte Sechskantschraube mit einem 5-mm-Sechskantschlüssel fest wie in der Abbildung unten gezeigt:

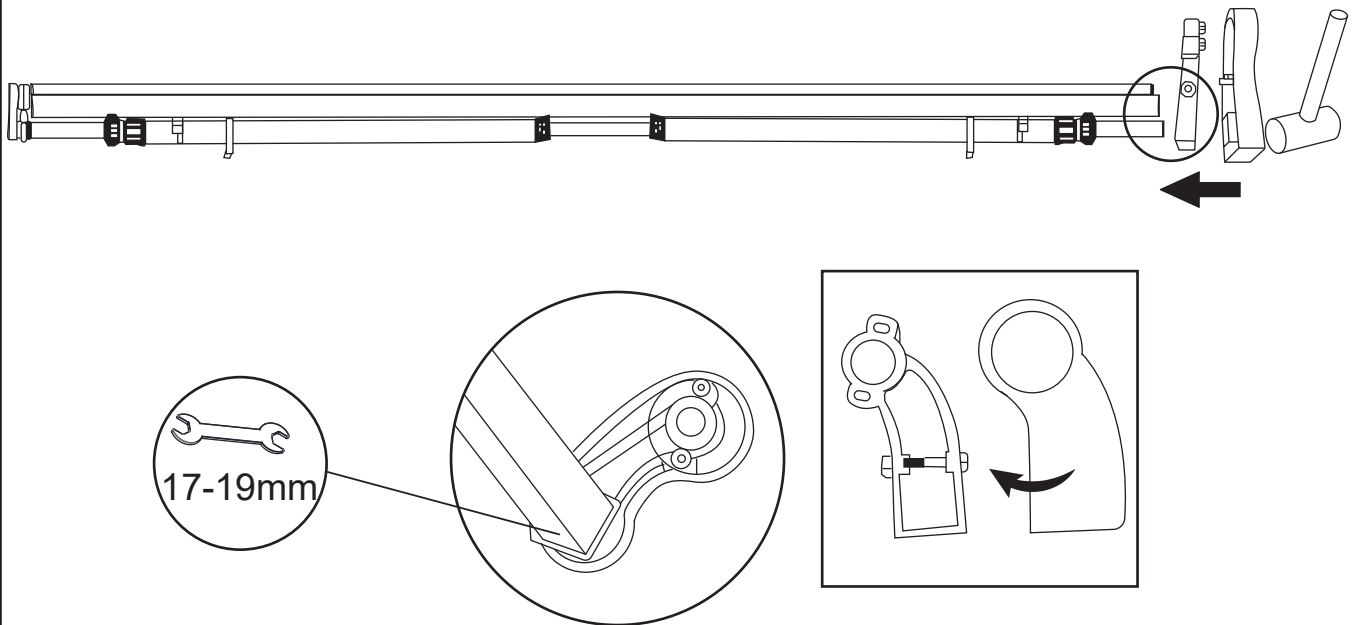

Schritt 12: Montage zur Komplettierung der Markise

Führen Sie den Volant durch die Nut der Frontstange, achten Sie auf die richtige Richtung und stellen Sie sicher, dass die linke und rechte Seite gleichmäßig ist. Schlagen Sie dann mit einem Hammer den Deckel der Frontstange auf das Ende der Frontstange wie in der Abbildung unten gezeigt:

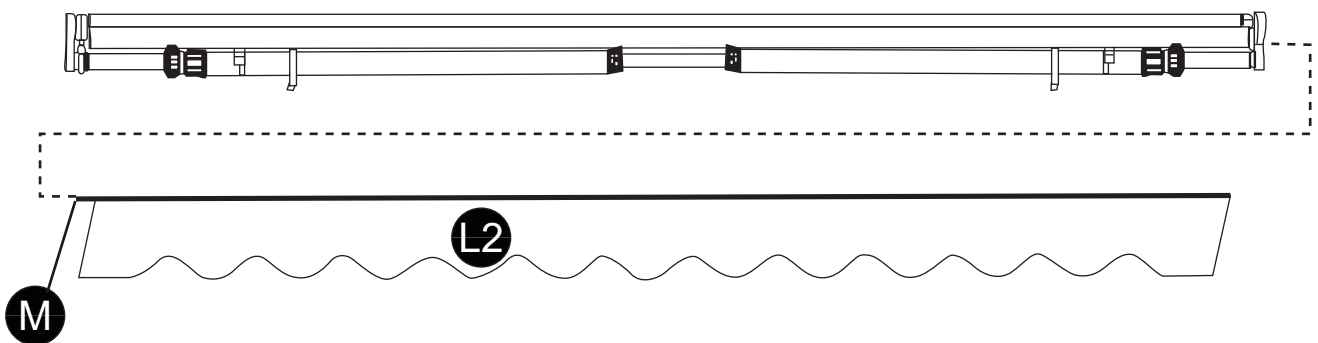

Falls der Teil der Frontstange leicht verformt ist, passen Sie ihn bitte bei Bedarf mit Werkzeugen selbst an.

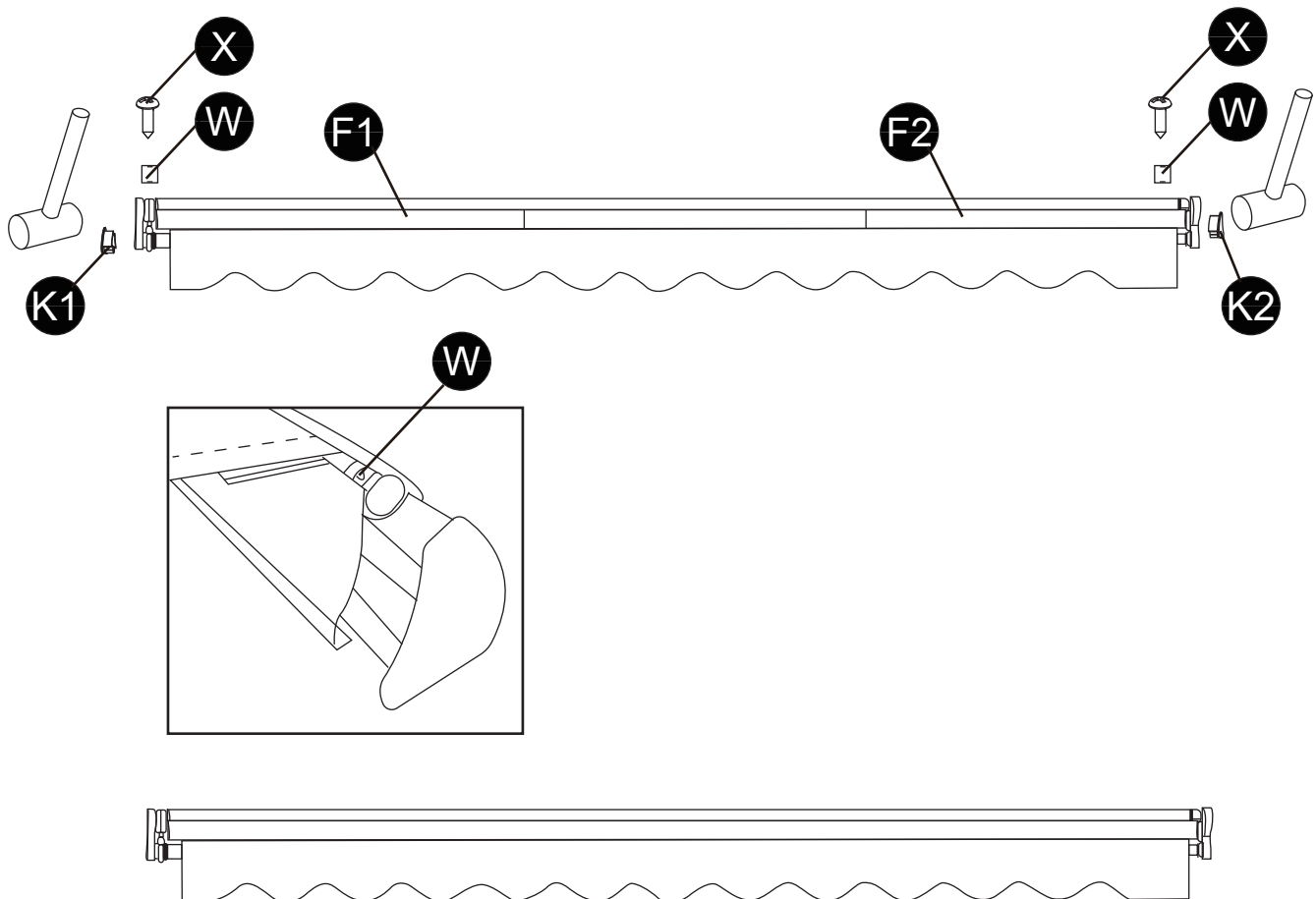

Wenn Sie feststellen, dass der Stoff ungleichmäßig aufgerollt ist oder die beiden Arme nicht gleichzeitig öffnen, überprüfen Sie die Stabilität der beiden Arme. Lösung: Justieren Sie die Position des Armstangenverbinders an der Frontstange nach außen, falls notwendig.

Specification

Produktname	RolladenMarkise (Details siehe Verpackung)
Material und Oberflächenbehandlung	Materialien: Stahlrohr, Aluminiumlegierung, Kunststoffteile, Polyesterstoff. Oberflächenbehandlung: Rohre: Sprühfarbe und Oxidation; Stoffoberfläche: PU, UV, wasserdicht.
Geeigneter Wandtyp	Verstärkter Betonwände, Ziegelwände und Holzwände
Empfohlene Installationshöhe	2.5m-4m 8'-13'
Geeignetes Wetter	Die Produkte sind zur Sonnenschutzabschirmung geeignet. Anwendbar bei Windstärke unter Stufe 5. Nicht geeignet für regnerisches Wetter.



Wandmontage

Hinweise zur Wandmontage:

Diese Markise kann an Beton-, Ziegel- und Holzwänden befestigt werden. Die mitgelieferten Schrauben sind für Beton- und Ziegelwände geeignet. Für Holz sind separate Schrauben erforderlich.

Wenn Sie Ihre Markise an Holz befestigen möchten, verwenden Sie bitte Holzschrauben mit geeigneter Länge und Durchmesser, um die Markise an den Holzträgern zu befestigen. Die Schraubengröße hängt von der Größe des Holzes ab; diese können in einem Baumarkt gekauft werden. Wir empfehlen die Beauftragung eines professionellen Handwerkers für die sicherste und stabilste Montage.

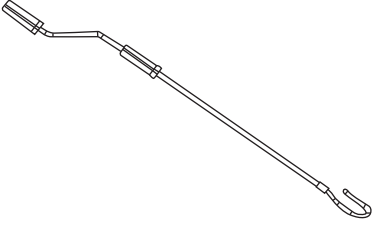
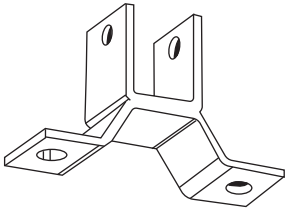
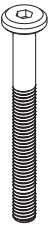
Befestigen Sie niemals die Wandhalterungen an losen Wandsteinen oder an Oberflächen, die nicht absolut fest sind!

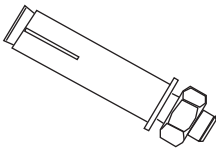
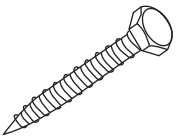
I  1pc	J  2pcs	P2  M8x55 2pcs	
Q  M8 2pcs	V  M8 2pcs	S  4pcs	Z  M10x72 4pcs

! Achtung

Die richtige Positionierung der Halterungen ist der wichtigste Aspekt bei der Montage der Markise. Es ist entscheidend, dass Sie alle Montagehalterungen an Pfosten, Balken, Stürzen oder anderen tragenden Bauelementen befestigen.

! WARNUNG

Eine unsachgemäße Befestigung kann zum Einsturz der Markise führen und Verletzungen verursachen oder zum Tod führen.

Höhe der Montage

Es ist wichtig, den Abhängbereich der Markise zu berücksichtigen, bevor Sie die Wandhalterungen befestigen. Wenn Sie die Markise beispielsweise über einer Terrassentür montieren möchten, lassen Sie mindestens 20,5 cm (8 Zoll) oberhalb des Türrahmens Platz, und stellen Sie sicher, dass die Markise das Öffnen und Schließen der Tür nicht behindert. Der Abhängewinkel kann nur minimal verändert werden, daher sollten Sie dies bei der Entscheidung, wo Sie die Markise anbringen, berücksichtigen.

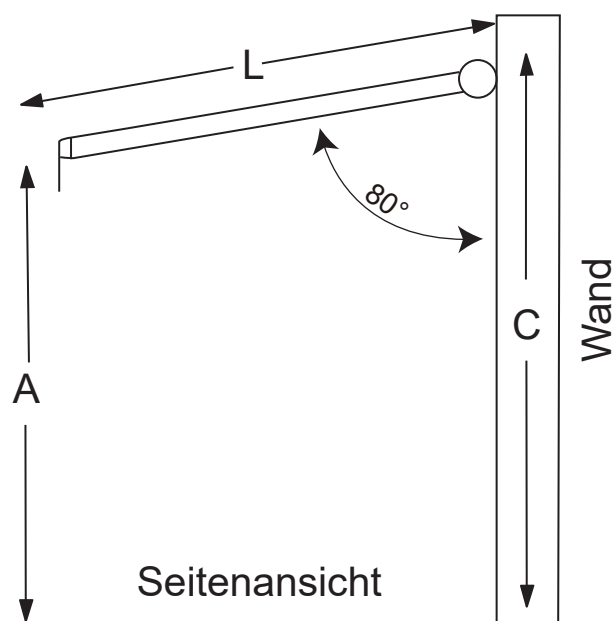

Empfohlene Installationshöhe: 8-13' (2,5-4 m). Der ideale Neigungswinkel (wenn vollständig ausgefahren) wurde bereits im Werk eingestellt, sodass in der Regel keine Änderung des Winkels erforderlich ist.

BERECHNUNGEN:

Sie können die folgende Formel verwenden, um den geeigneten Winkel zu berechnen.

$$C = A + 0,17 * L$$

A = Die gewünschte Höhe der Frontstange

L = Die Länge des ausgestreckten Arms

C = Die Höhe der Wandhalterungen

Wir empfehlen, dass die Stoffoberfläche beim Öffnen einen Winkel von etwa 80 Grad zur Wand bildet.

SCHRITT 1

Messung des Montagestandortes

1. Messen Sie die Länge Ihrer Markise entlang der Wand, an der Sie sie installieren möchten. Diese Linie wird den höchsten Punkt Ihrer Markise darstellen und sich mit der Oberkante der Wandhalterung ausrichten. Verwenden Sie ein Nivelliergerät oder eine Wasserwaage, um eine Kreidelinie über die gesamte Strecke zu ziehen.
2. Wichtig: Überprüfen Sie, ob die Linie über die gesamte Länge hinweg waagrecht ist.
3. Stellen Sie sicher, dass die Linie über der Terrassentür, dem Fenster oder einer anderen Öffnung zentriert ist, falls zutreffend.
4. Nachdem Sie eine gerade, zentrierte Linie haben, messen Sie den Mittelpunkt und markieren ihn. Hier wird die mittlere Wandhalterung installiert.
5. Nehmen Sie eine Wandhalterung und platzieren Sie die Oberseite vollständig waagrecht unter der Linie, wie in der Abbildung unten gezeigt. Markieren Sie mit Kreide oder einem Bleistift die Position aller Wandhalterungen und deren Bohrlöcher. Beachten Sie, dass der Abstand zwischen den einzelnen Wandhalterungen gleich sein sollte.

Markise < 10.8' (3.5m)	Benötigt insgesamt nur 2 Wandhalterungen: eine für jedes Ende der Tragrohrstäben.
Markise = 10.8-14' (3.5-4m)	Benötigt insgesamt 3 Wandhalterungen: eine für jedes Ende und eine in der Mitte.

Der Abstand zwischen Dachvorsprung und Wandhalterung beträgt $\geq 3.9''$ (10 cm).

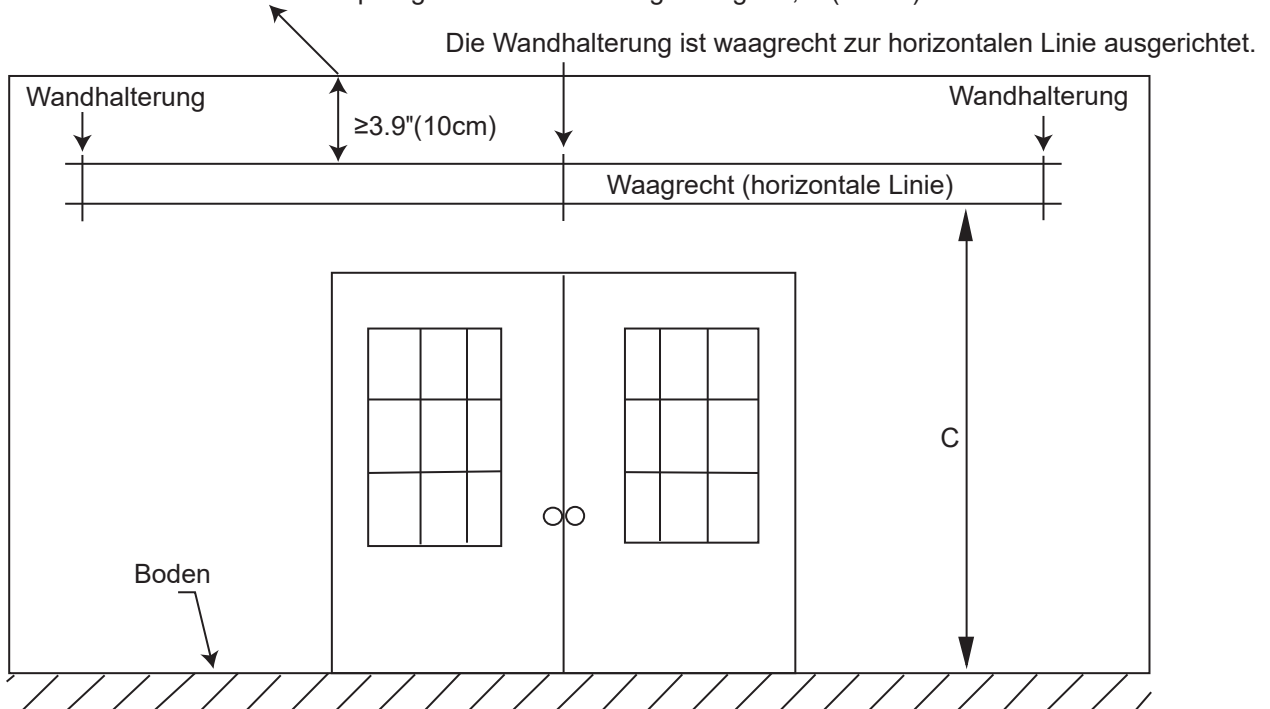

SCHRITT 2

Bohrung der Schraubenlöcher

1. Nachdem Sie eine gerade, waagerechte Linie an der Wand mit den markierten Positionen der Wandhalterungen und deren Bohrlöchern haben, können Sie nun die Löcher bohren, um die Halterungen zu montieren.

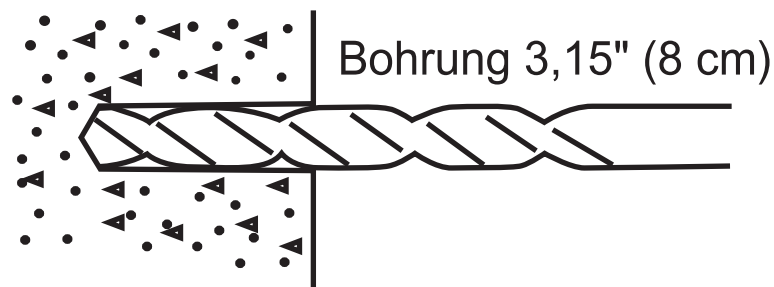

2. Verwenden Sie einen 14-mm-Bohrer, um das erste Schraubenloch etwa 3,15" (8 cm) tief zu bohren, wie in der Abbildung gezeigt. Dies muss durch festes Mauerwerk oder Beton gebohrt werden, um die notwendige Unterstützung für die Markise zu bieten.

3. Bohren Sie die verbleibenden Löcher genau wie in Schritt 2.

! ACHTUNG

Alle Schraubenlöcher müssen sowohl vertikal als auch horizontal ausgerichtet sein, um sicherzustellen, dass die Markise gerade hängt.

Überprüfen Sie die Ausrichtung noch einmal, bevor Sie bohren, wenn Sie sich nicht sicher sind.

! ACHTUNG

Der Durchmesser und die Tiefe der Montageschraubenlöcher müssen der Größe der Dübel entsprechen.

SCHRITT 3

Vorbereitung der Montage

1. Nachdem alle Löcher gebohrt wurden, setzen Sie die Schwerlastanker ein.
2. Es kann notwendig sein, die Schwerlastanker mit einem Holzhammer (oder einem anderen nichtmetallischen Hammer) einzutreiben.



Wenn ein Hammer für die Installation erforderlich ist, empfehlen wir, die Mutter locker auf das Gewinde zu setzen, bevor Sie mit dem Hämmern beginnen, um eine Beschädigung der Gewinde zu vermeiden.

3. Stellen Sie sicher, dass die Schwerlastanker fest an ihrem Platz sitzen, aber noch etwa 1 Zoll (2,5 cm) oder weniger aus der Wand herausragen – genug, damit die Wandhalterung darauf montiert werden kann.

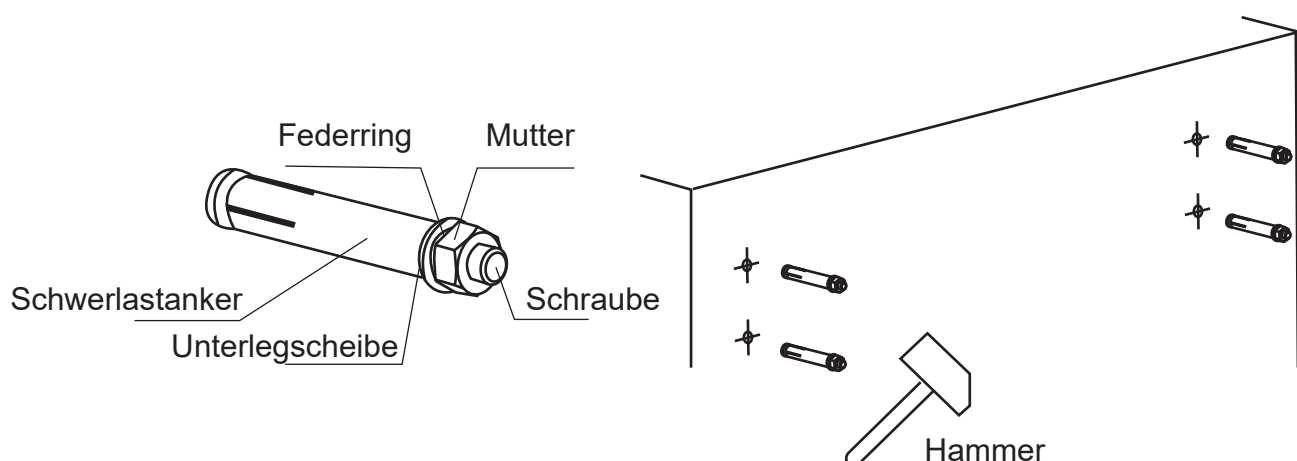

SCHRITT 4

Montage der Wandhalterungen

1. Nachdem die Schwerlastanker sicher in der Wand installiert sind, entfernen Sie die lockeren Muttern, die über die Schwerlastanker gesetzt wurden.
2. Setzen Sie eine Wandhalterung auf ein Set von Schwerlastankern. Dies sollte problemlos passen, wenn die Bohrlöcher richtig ausgerichtet sind.
3. Sobald die Wandhalterung auf den Schwerlastankern liegt, setzen Sie eine Unterlegscheibe auf das Gewinde. Befestigen Sie dann die Mutter, wie in der Abbildung gezeigt.

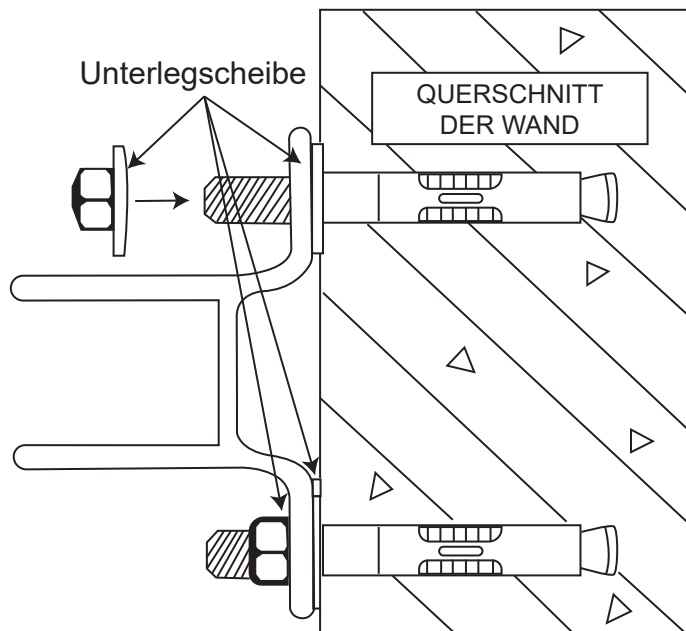

4. Die Halterungen **MÜSSEN** fest an der Wand sitzen. Falls es irgendeine Bewegung gibt, müssen Sie sie weiter anziehen.
5. Wiederholen Sie diesen Schritt für jede Wandhalterung. Sobald Sie dies getan haben, sind alle Wandhalterungen sicher an ihrem Platz montiert.

SCHRITT 5

Montage der Markise

1. Nachdem die Wandhalterungen sicher an ihrem Platz sind, ist es nun an der Zeit, die Markise an den Halterungen zu montieren.
2. Legen Sie die Tragrohrstäbe auf die Wandhalterungen und ziehen Sie sie mit den Sechskantschrauben fest.
3. Befestigen Sie schließlich alle Schwerlastanker.
4. Verwenden Sie die Handkurbel oder einen Motor (falls zutreffend), um die Markise vollständig zu öffnen. Die Frontstange sollte waagrecht sein.
5. Herzlichen Glückwunsch! Ihre Markise ist montiert. Wenn Sie mit der Höhe der Frontstange (Neigungswinkel der Markise) zufrieden sind, lehnen Sie sich zurück und genießen Sie! Wenn nicht, lesen Sie weiter.

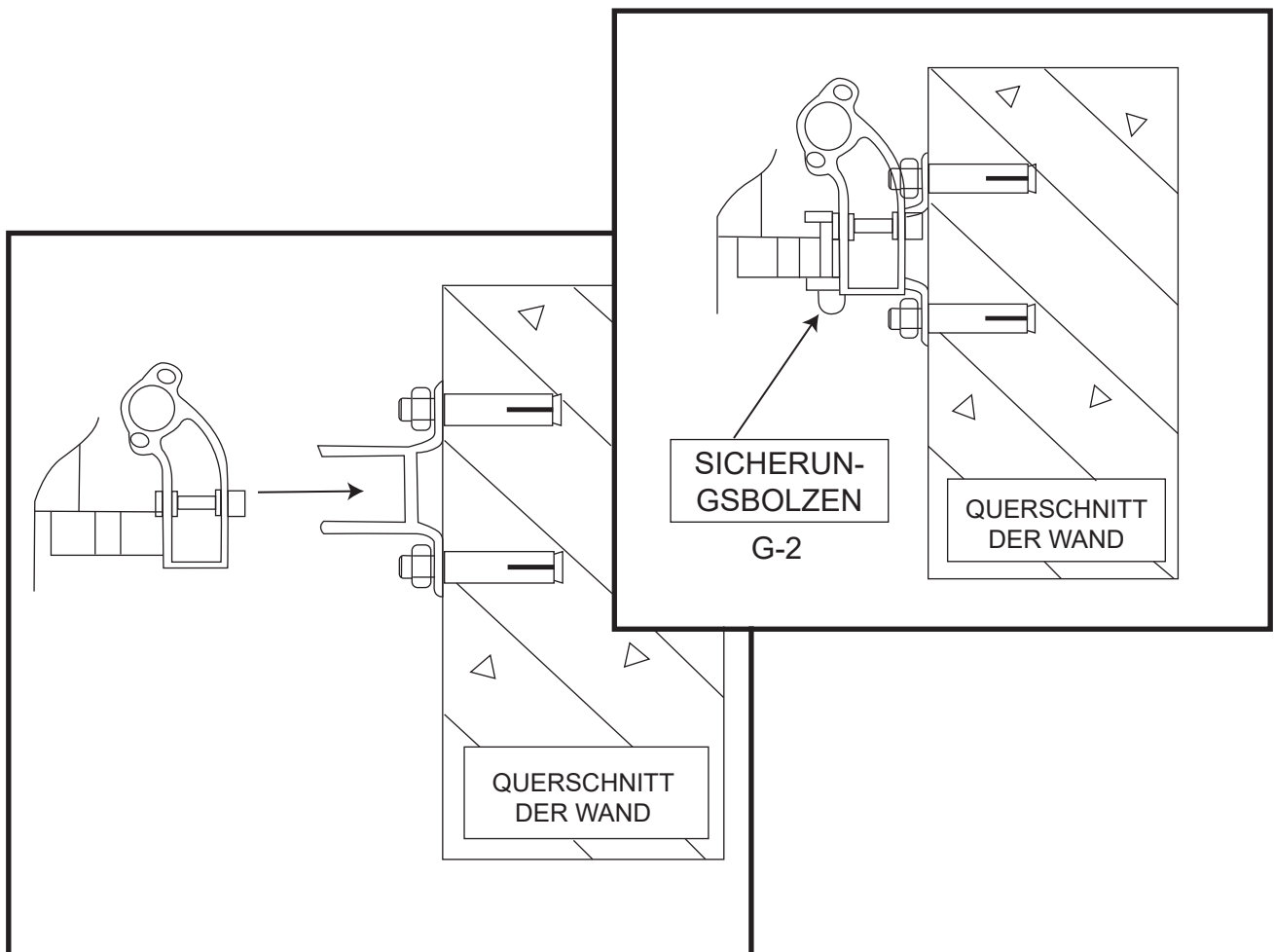

OPTIONALE INSTALLATION

Einstellung der Markise

Each awning comes with a pre-set angle that is considered ideal. However, if you need to make an adjustment, it can be done in just a few easy steps.

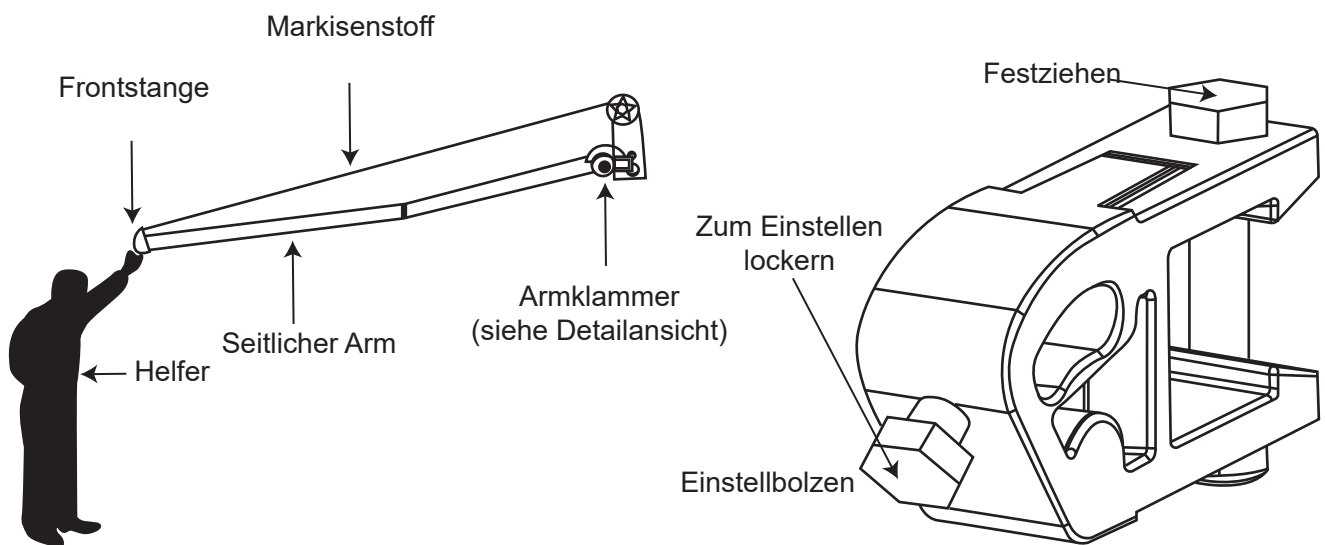

! WARNUNG

Das Anheben der Frontstange verringert den Neigungswinkel des Stoffs, wodurch das Risiko steigt, dass sich Regenwasser auf dem Stoff sammelt. Um zu verhindern, dass die Markise aufgrund des Gewichts des Regenwassers zusammenbricht, müssen Sie die Markise bei Abwesenheit einfahren. Das Unterlassen dieser Maßnahme könnte zu einer beschädigten Markise oder zu Personenschäden führen.

Hinweis: Stellen Sie sicher, dass die Frontstange vollständig eben eingestellt ist. Jede Fehlausrichtung führt zum unsachgemäßen Einfahren der Markise.

HÄUFIGE FEHLER

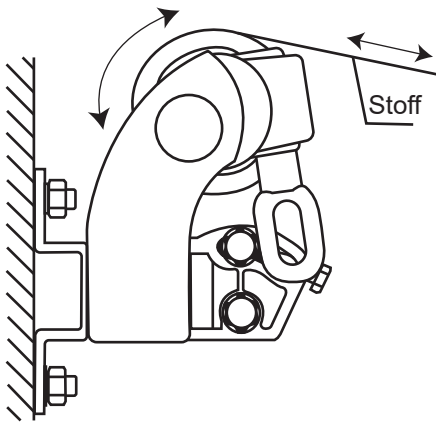

Richtige Ausführung

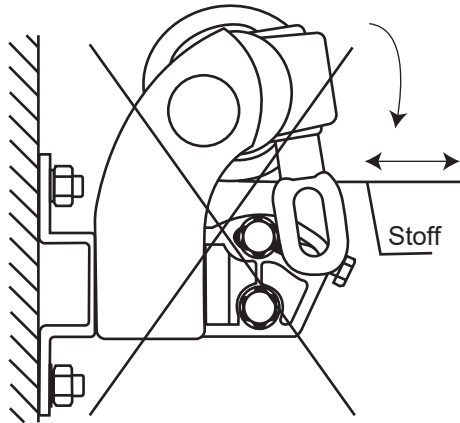

Falsche Ausführung

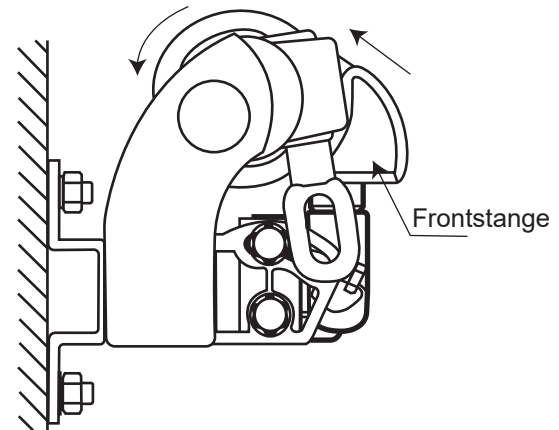

WARNUNG

Wenn die Frontstange die Wickelwelle wie in der Abbildung gezeigt berührt, versuchen Sie nicht, sie weiter aufzurollen, da sonst das Produkt beschädigt werden könnte.

Ansprechpartner
tectake GmbH
Tauberweg 41
97999 Igersheim
Telefon: +49 7931 991 920
www.tectake.de
E-Mail: verkauf@tectake.de

Instructions de montage de l'auvent

3x2.5M 2.5x2M

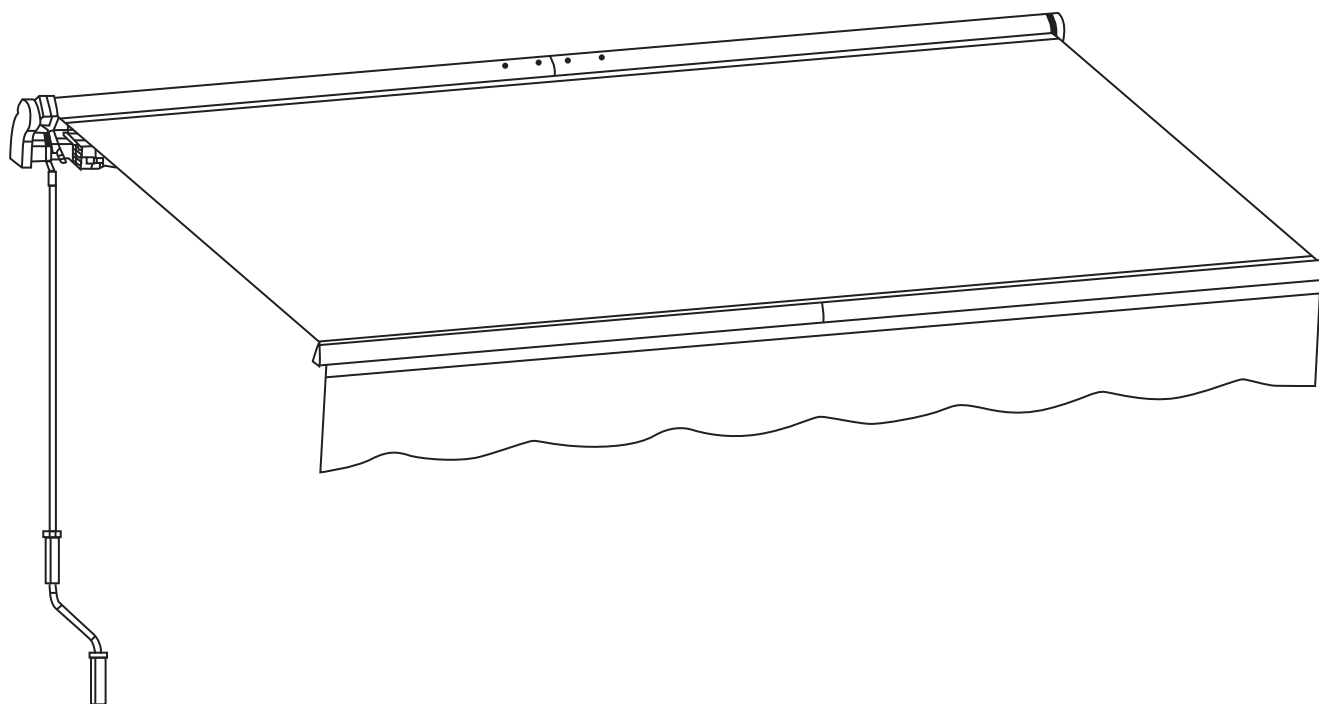

Merci d'avoir acheté notre store rétractable ! Nous espérons que vous apprécierez notre produit pendant de nombreuses années.







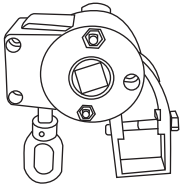
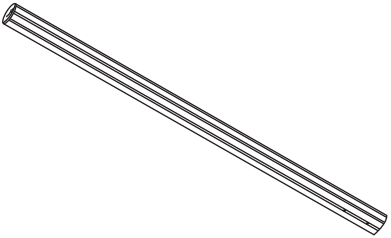
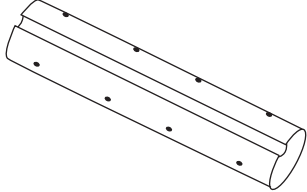
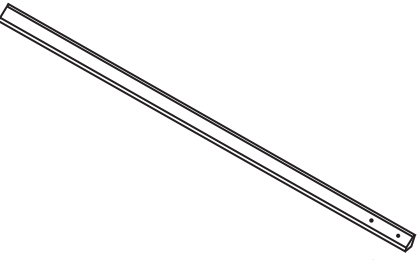
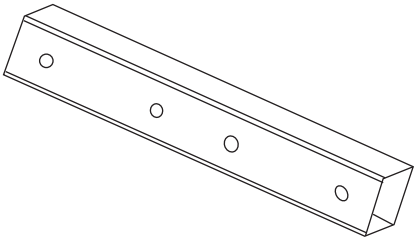
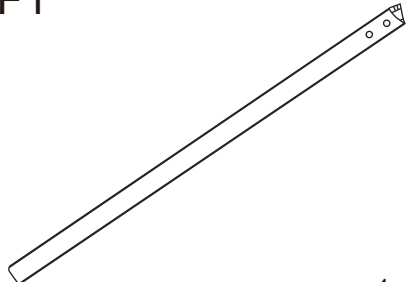
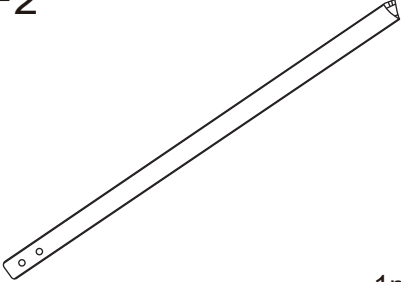
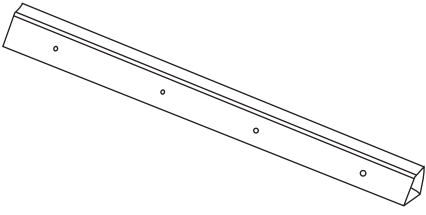
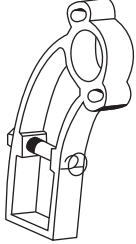
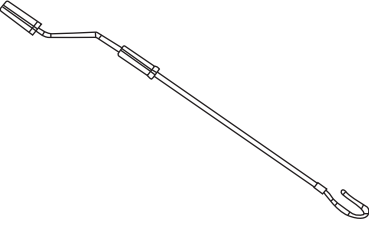
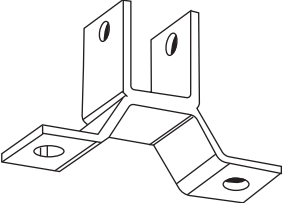
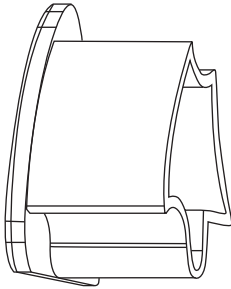
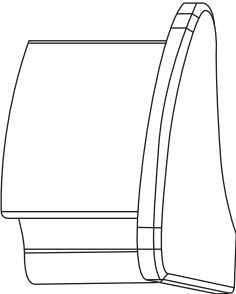
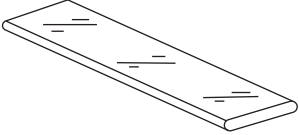
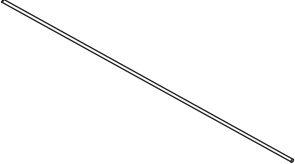

Pour assurer votre sécurité personnelle lors de l'installation et pour tirer le meilleur parti de l'utilisation de l'appareil, veuillez lire l'intégralité de ce manuel avant de commencer l'installation.

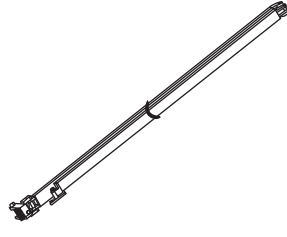
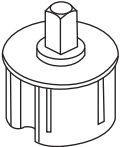
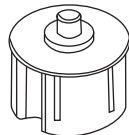
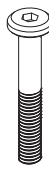
Nous recommandons d'installer cet auvent à deux personnes. Si vous estimez que ce processus est trop difficile à réaliser seul, nous vous conseillons de demander de l'aide auprès d'un entrepreneur local en bâtiment ou en rénovation.

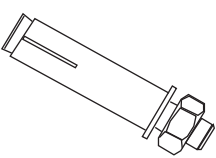

Veuillez contacter notre service clientèle pour obtenir de l'aide si vous avez des problèmes ou si vous avez besoin d'aide lors de l'assemblage, si vous avez des pièces manquantes ou défectueuses, ou pour toute autre question, nous ferons de notre mieux pour vous aider.

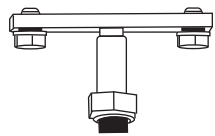
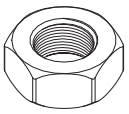

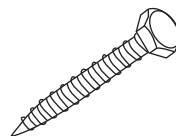
**Liste des pièces :
Installation optionnelle**

<p>A</p>  <p>1pc</p>	<p>B</p>  <p>2pcs</p>	<p>C</p>  <p>1pc</p>
<p>D</p>  <p>2pcs</p>	<p>E</p>  <p>1pc</p>	<p>F1</p>  <p>1pc</p>
<p>F2</p>  <p>1pc</p>	<p>G</p>  <p>1pc</p>	<p>H</p>  <p>1pc</p>
<p>I</p>  <p>1pc</p>	<p>J</p>  <p>2pcs</p>	<p>K1</p>  <p>1pc</p>
<p>K2</p>  <p>1pc</p>	<p>L</p>  <p>1pc</p>	<p>M</p>  <p>3pcs</p>

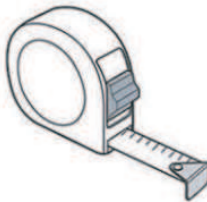
<p>N1</p>  <p>1pc</p>	<p>N2</p>  <p>1pc</p>	<p>O1</p>  <p>1pc</p>	
<p>O2</p>  <p>1pc</p>	<p>P1</p>  <p>M6x40</p> <p>4pcs</p>	<p>P2</p>  <p>M8x55</p> <p>2pcs</p>	<p>Q</p>  <p>M8</p> <p>2pcs</p>
<p>R</p>  <p>M6</p> <p>4pcs</p>	<p>S</p>  <p>4pcs</p>	<p>T</p>  <p>M5x16</p> <p>16pcs</p>	<p>U</p>  <p>2pcs</p>
<p>V</p>  <p>M8</p> <p>2pcs</p>	<p>W</p>  <p>2pcs</p>	<p>X</p>  <p>M3x10</p> <p>2pcs</p>	<p>Z</p>  <p>M10x72</p> <p>4pcs</p>

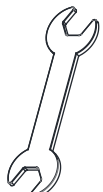
Veillez préparer les outils ci-dessous avant l'assemblage (non inclus).

<p>Ruban à mesurer</p>	<p>Maillet non métallique</p>	<p>Clé à molette (clés de M17 et M14)</p>
		

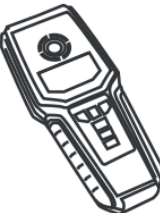
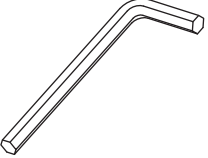
Tournevis cruciforme	Perceuse électrique avec foret de 14 mm	Cordeau à tracer, niveau à bulle ou niveau à eau	Clé de 8 mm
			

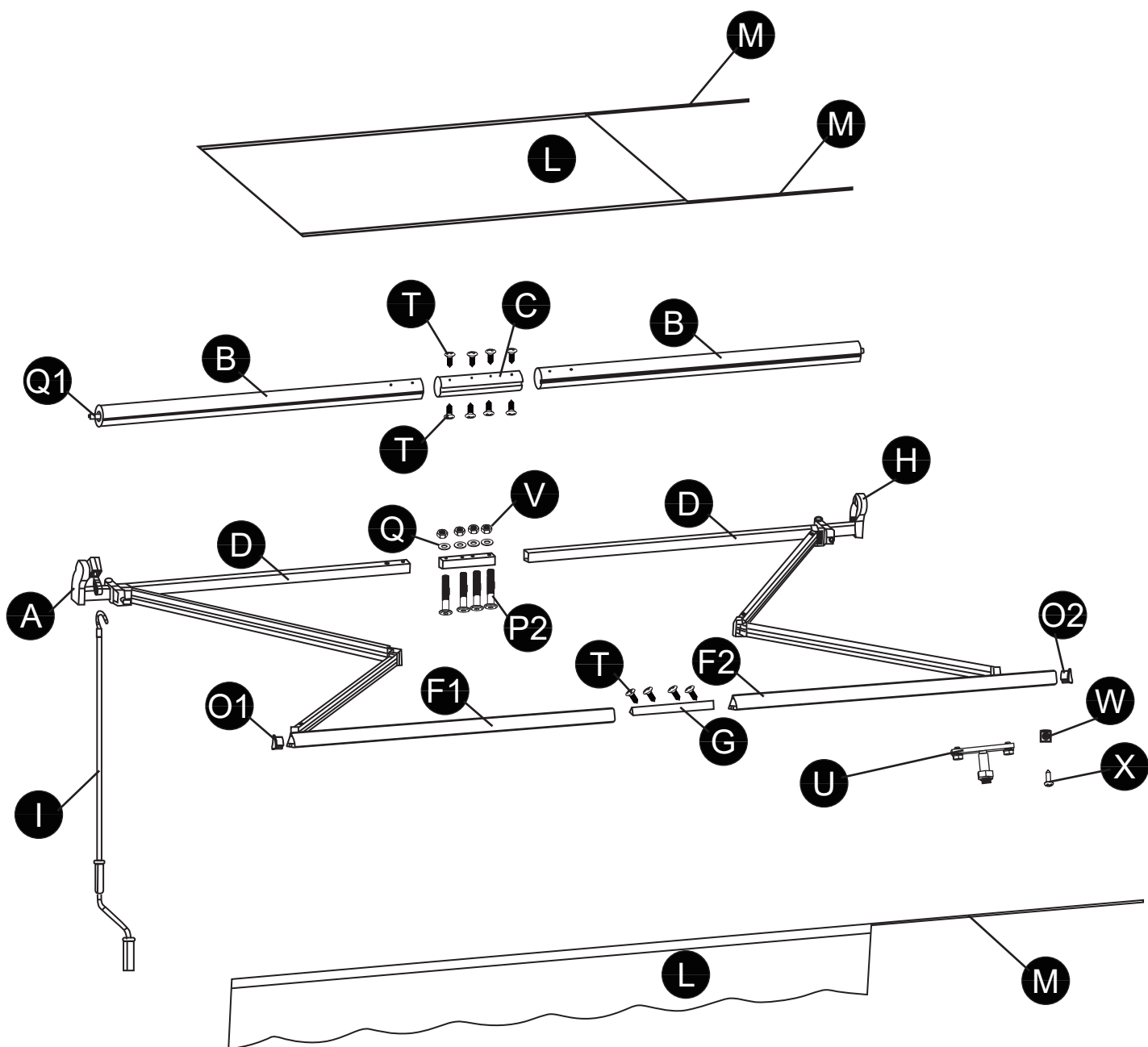

Préparation de l'espace de travail

1. Avant de commencer, il est préférable de disposer tous les outils nécessaires.

Reportez-vous à la section outils requis pour obtenir la liste des outils nécessaires

AVERTISSEMENT

Ne retirez PAS le film de sécurité qui maintient les bras de l'auvent vers le bas. Des blessures graves peuvent résulter d'un retrait prématuré du film de sécurité.

2. Ouvrez la boîte du store et déballez chaque pièce avec précaution pour éviter d'endommager le produit.

3. Disposez chaque pièce de l'auvent pour vous assurer que toutes les pièces sont présentes. Reportez-vous au diagramme des pièces pour obtenir des informations détaillées sur les pièces.

4. Ouvrez la petite boîte intérieure qui contient les petites pièces et disposez-les également.

Assemblage :

Étape 1 : Assemblage du rouleau

Maintenez les rouleaux alignés, assemblez le rouleau avec les connecteurs et fixez-le avec les boulons correspondants comme indiqué dans les figures ci-dessous :

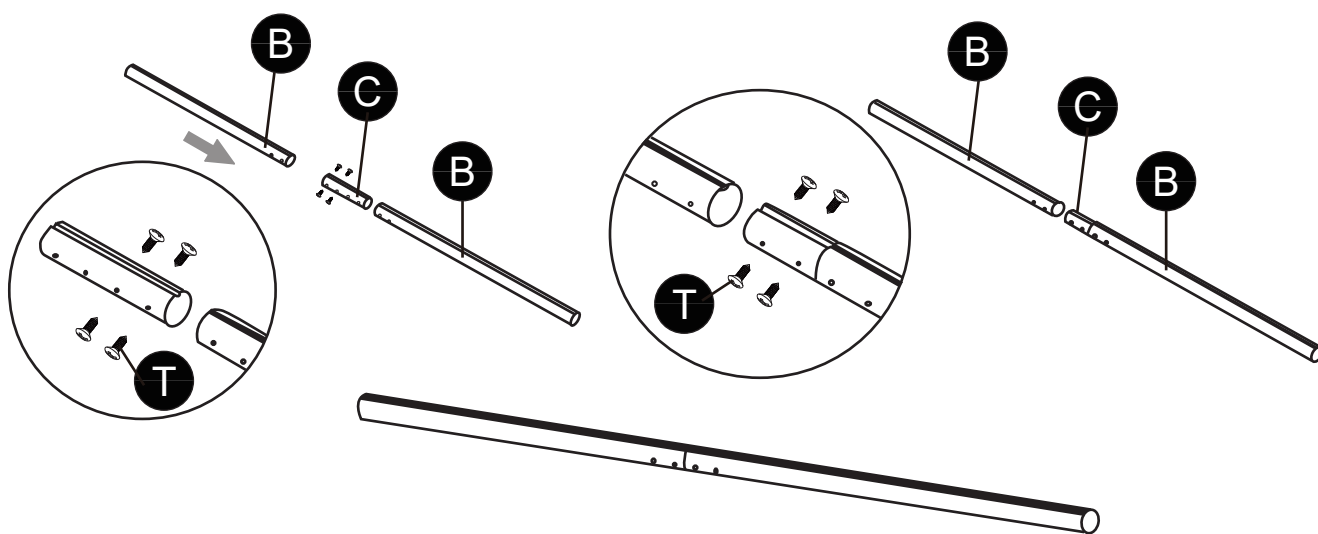

Étape 2 : Assemblage de la tige du tube de support et du bras

Alignez les quatre côtés, connectez les tiges des tubes de support avec les connecteurs et fixez-les avec les boulons correspondants comme indiqué dans les figures ci-dessous :

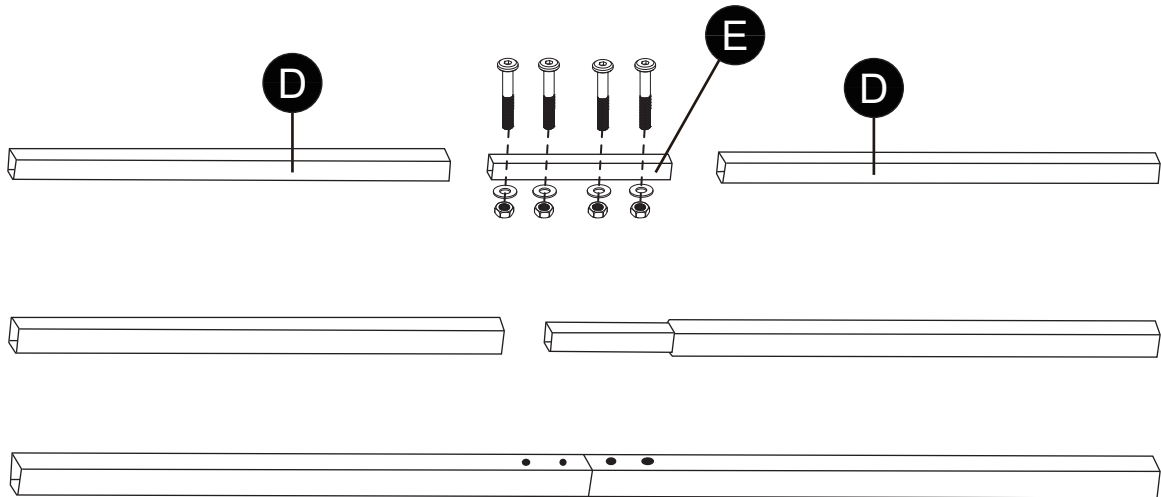

Assemblez ensuite les bras aux tiges du tube de support comme indiqué dans les figures ci-dessous. Les deux bras doivent être orientés dans la même direction, la corde du bras ne peut pas être déverrouillée tant que l'ensemble de l'assemblage n'est pas terminé.

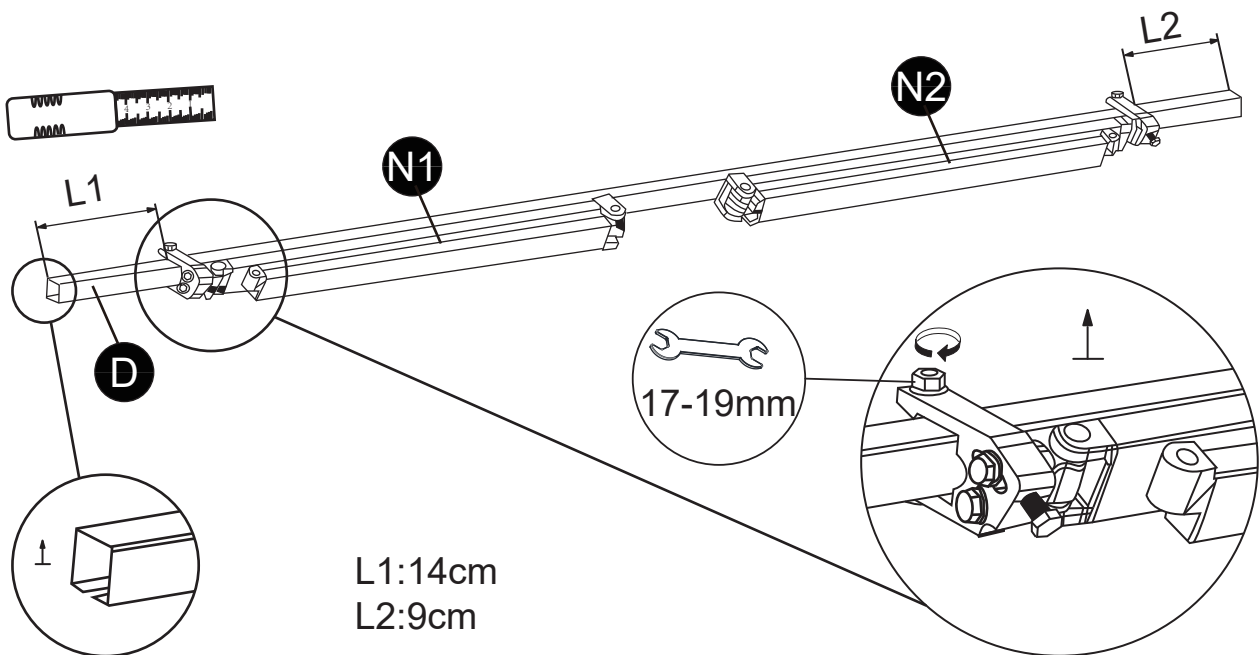

Étape 3 : Assemblage de la barre frontale

Connectez la barre avant avec les connecteurs (pos.7) et fixez-la avec les boulons correspondants comme indiqué dans les figures ci-dessous (veuillez garder la barre avant alignée).

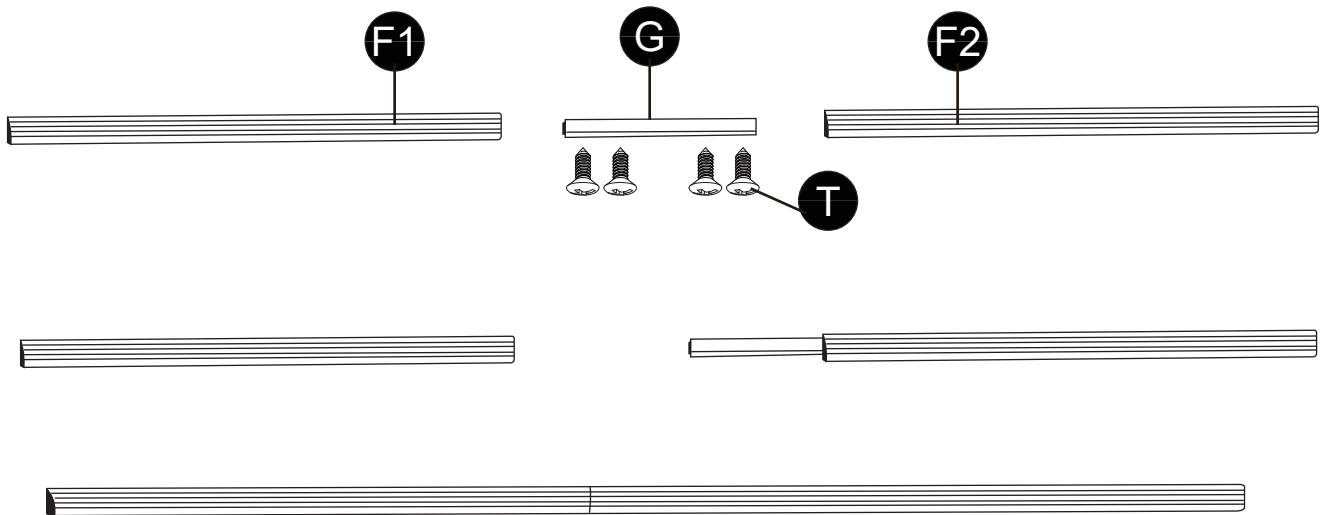

Étape 4 : Assemblage du support de poignet de la barre frontale

Glissez les pieds (pos. 18) dans la barre frontale sans les serrer. Comme le montre la figure ci-dessous :

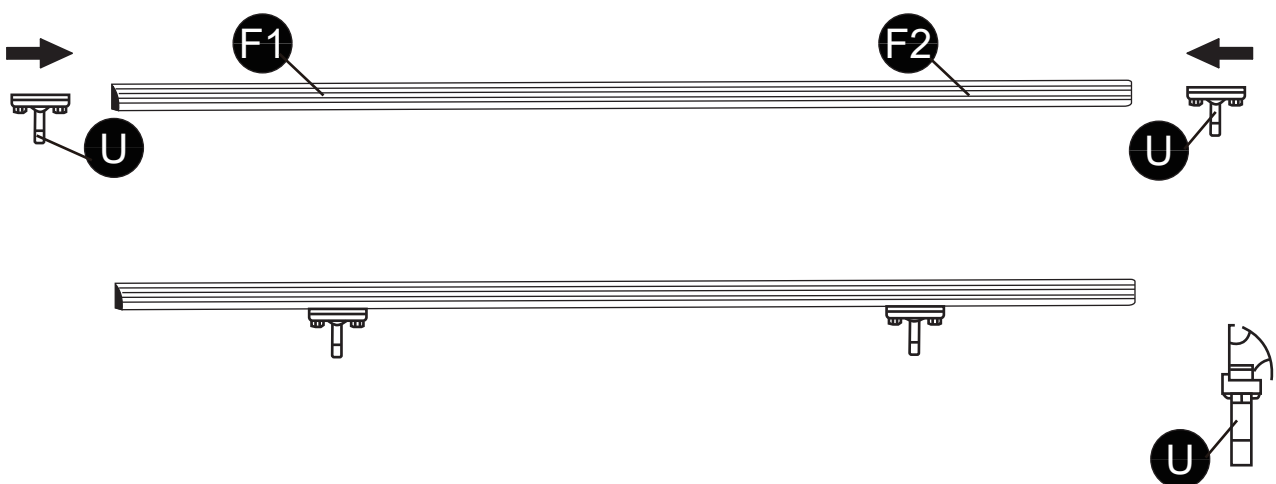

Étape 5 : Assemblage du bras avec la barre frontale

Introduire le boulon des pieds de la barre avant (pos. 18) dans le trou du petit bras, puis positionner la barre avant. Après le positionnement, serrer l'écrou à l'aide d'une clé, comme indiqué dans la figure ci-dessous :

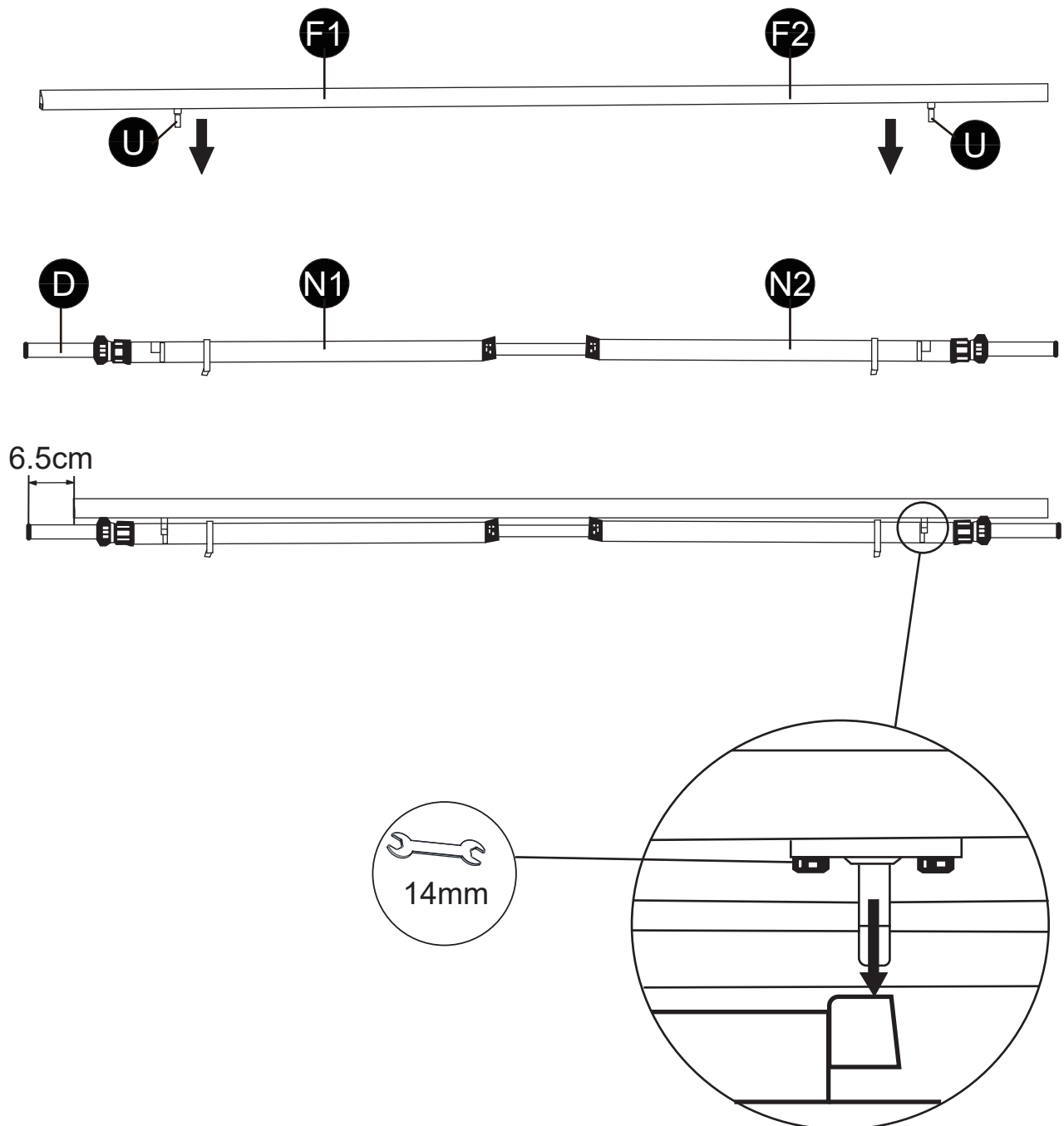

Étape 6 : Relier l'écrou autobloquant

Placez les écrous autobloquants sur les vis situées à la base des pieds et serrez-les fermement à l'aide d'une clé, comme le montre la figure ci-dessous :

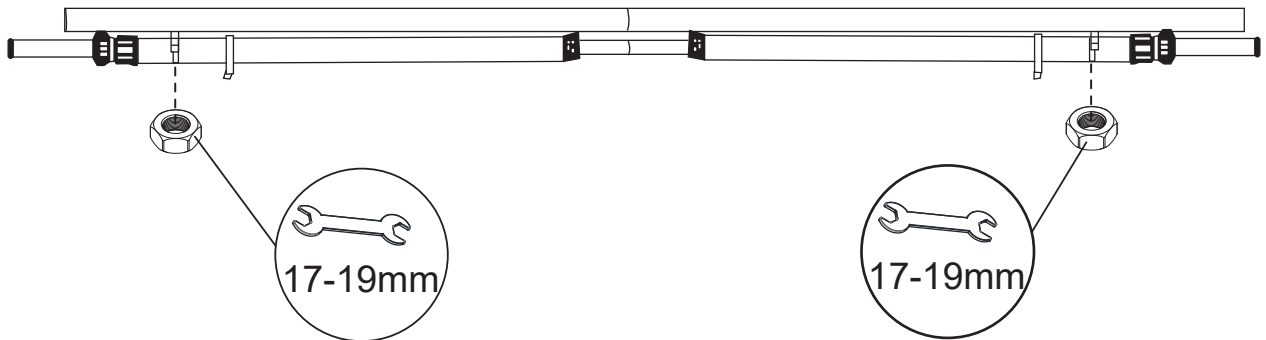

ATTENTION : AVANT DE SERRER LES ÉCROUS, ASSUREZ-VOUS QUE LES BRAS SOIENT CORRECTEMENT ALIGNÉS.

Étape 7 : Support du rouleau gauche avec l'assemblage de la boîte d'engrenage

Enfoncez le support de rouleau gauche avec la boîte d'engrenage dans l'extrémité gauche de la tige du tube de support à l'aide d'un marteau, puis serrez le boulon hexagonal gauche. Comme indiqué sur la figure ci-dessous :

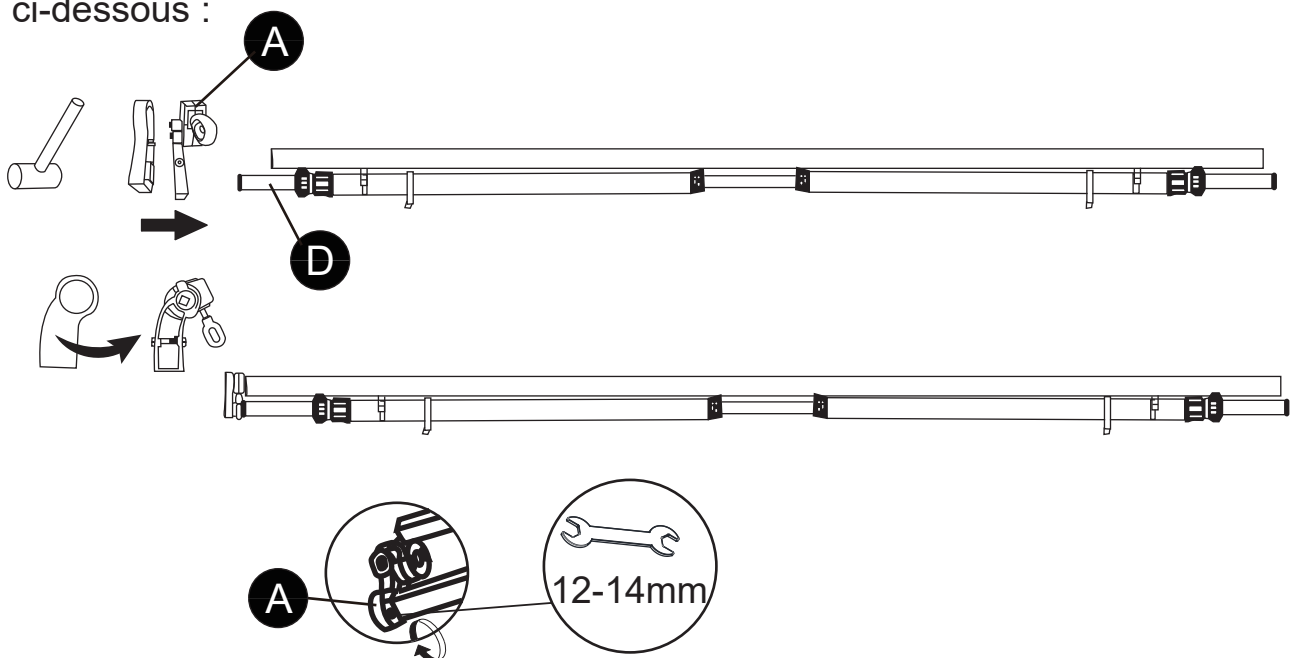

Étape 8 : Assemblage du tissu et de la cantonnière

Ouvrez le sac de tissu. Étalez les deux tissus 14A et la cantonnière 14B et utilisez le fil de guidage du tissu pour le faire passer à travers le tissu. Comme le montre la figure ci-dessous

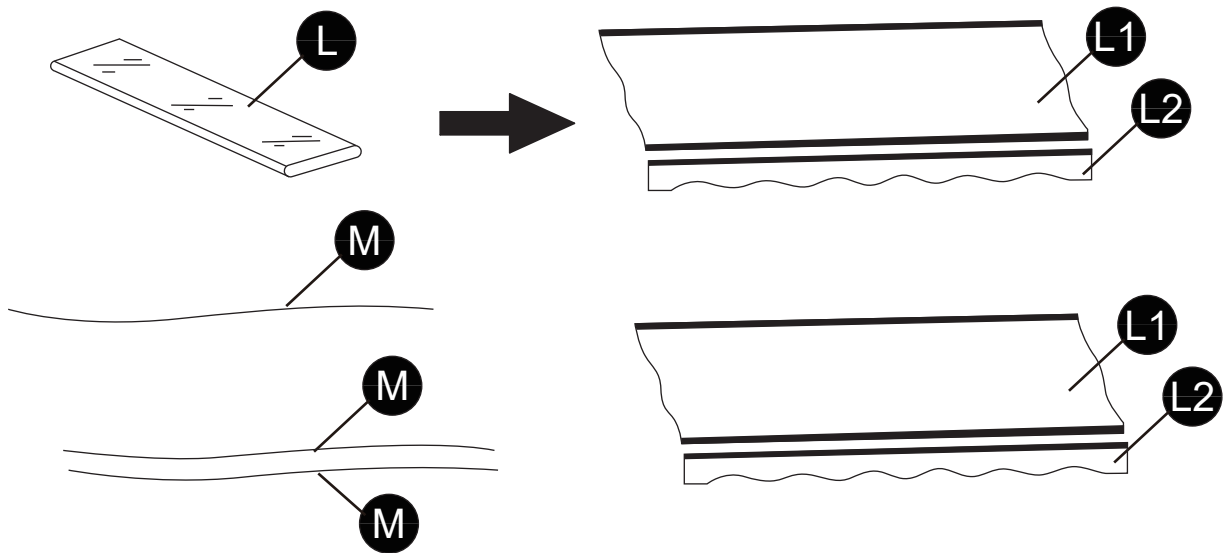

Étape 9 : Enrouler le tissu sur le rouleau

Enroulez le tissu sur le rouleau, en faisant attention à la direction du tissu, comme indiqué dans la figure ci-dessous :
Veuillez orienter le tissu vers le haut lors de l'assemblage. Conservez le même espace (X) aux deux extrémités.
Étendre le tissu lentement pour éviter de l'endommager.

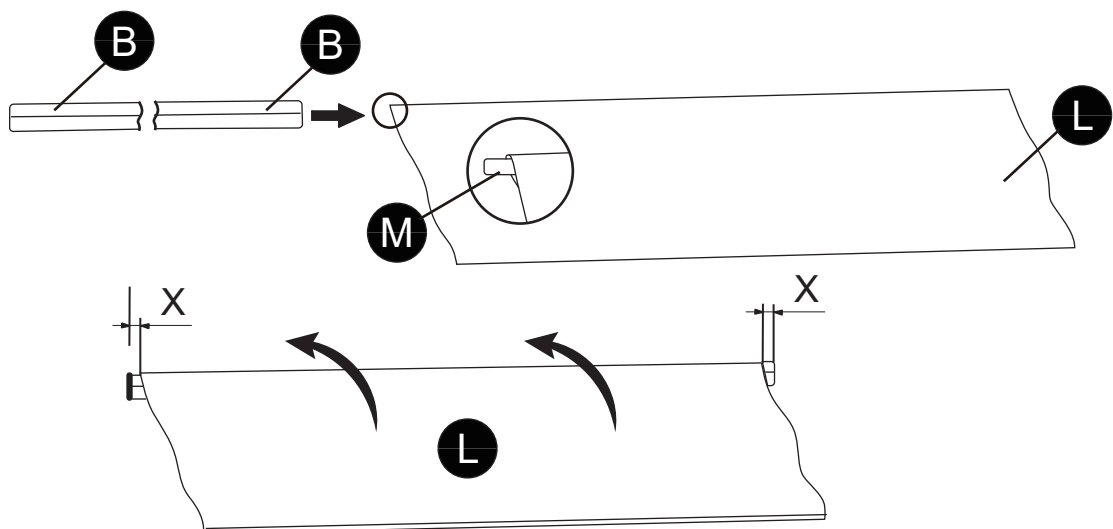

Étape 10 : tissu

Insérez une extrémité du tissu dans la rainure de la barre avant et répartissez le tissu uniformément après l'avoir tiré jusqu'au bout. Insérez ensuite l'axe du rouleau dans le trou carré du boîtier de la boîte de vitesses, comme indiqué dans la figure ci-dessous.

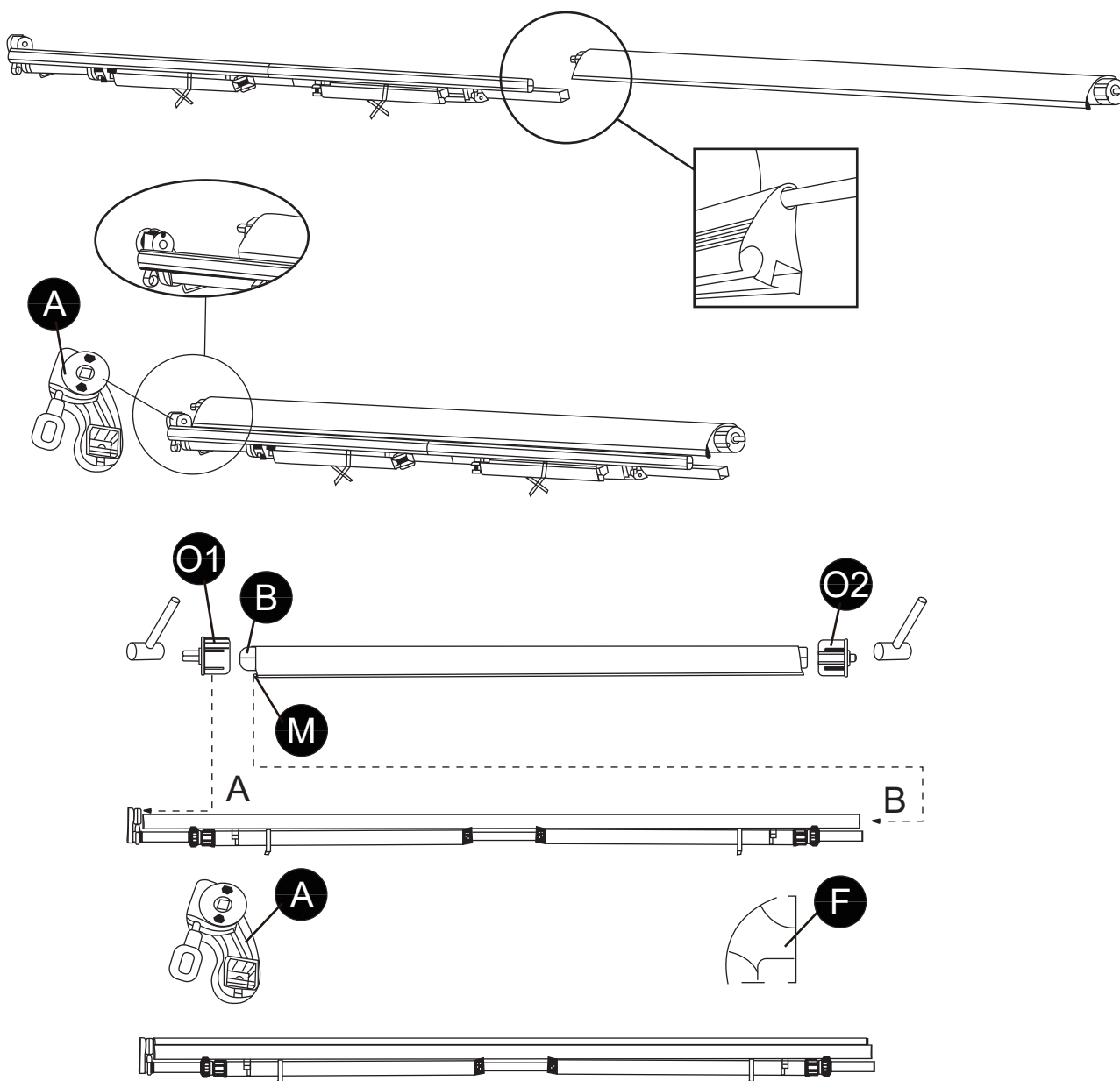

Si la partie de la barre avant est légèrement déformée, veuillez l'ajuster vous-même à l'aide d'outils.

Étape 11 : Assemblage du support du rouleau droit

Insérez l'axe du rouleau dans le capuchon du tube du rouleau tout en guidant simultanément la tige du tube de support dans le support du rouleau droit en la tapotant. Ensuite, serrez la vis hexagonale droite à l'aide d'une clé hexagonale de 5 mm, comme indiqué dans la figure ci-dessous :

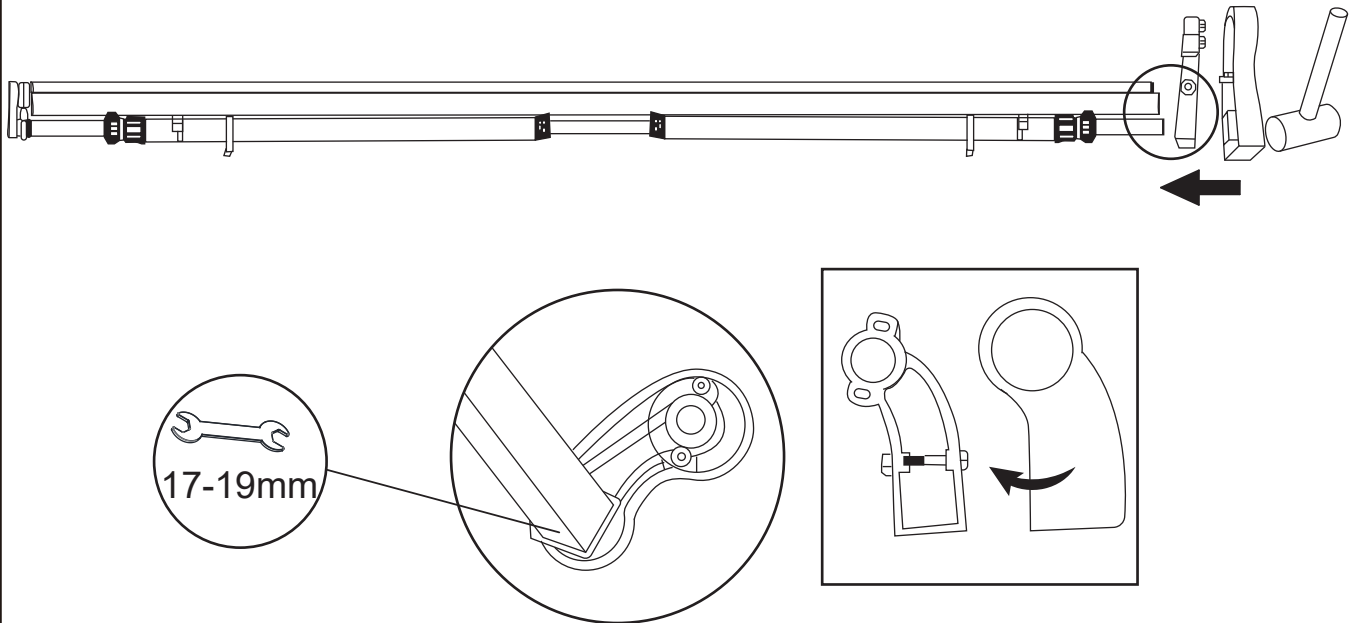

Étape 12 : Assembler pour former un auvent complet

Insérez la cantonnière dans la rainure de la barre avant, en veillant à ce qu'elle soit orientée correctement et alignée uniformément sur les côtés gauche et droit. Ensuite, utilisez un marteau pour fixer le capuchon de la barre avant à l'extrémité de la barre avant, comme indiqué dans la figure ci-dessous :

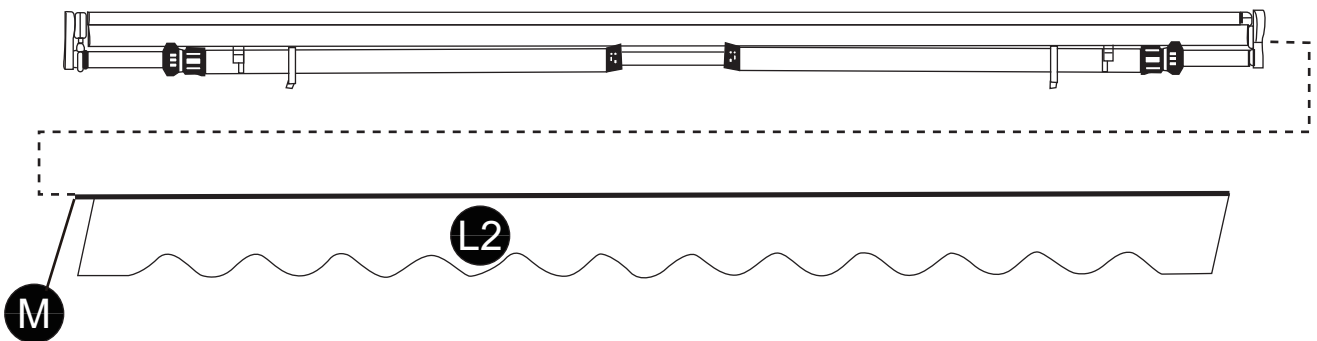

Si la partie de la barre avant est légèrement déformée, veuillez l'ajuster vous-même à l'aide d'outils.

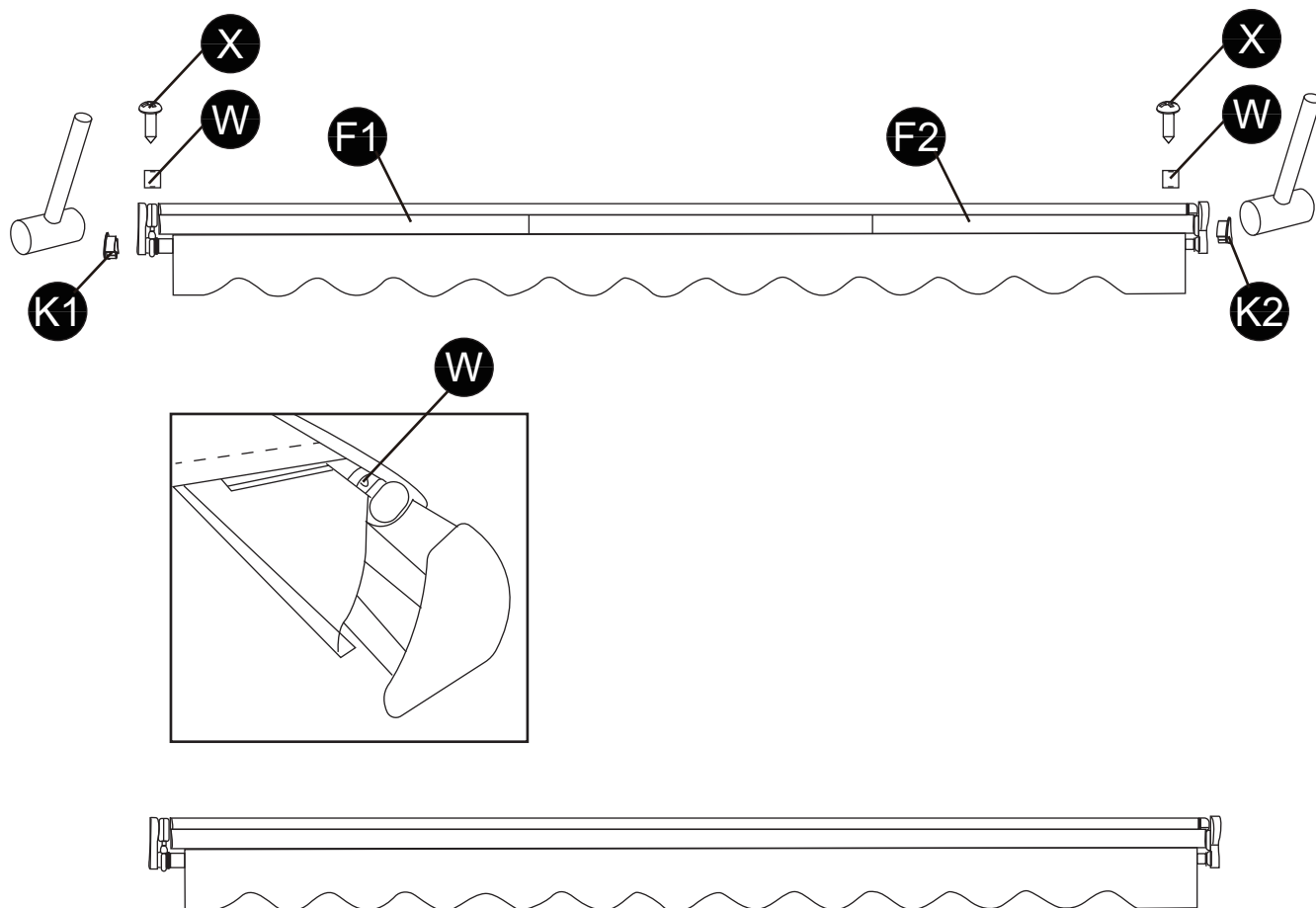

Si vous constatez que le tissu s'enroule de manière inégale ou que les deux bras ne s'ouvrent pas en même temps, vérifiez la stabilité des deux bras. Solution : Ajustez la position du connecteur de la barre de bras sur la barre avant vers l'extérieur si nécessaire.

Spécifications

Nom du produit	Auvent rétractable (voir détails sur l'emballage)
Matériau et traitement de surface	Matériaux : Tube d'acier, alliage d'aluminium, pièces en plastique, tissu en polyester Traitement de service : Tubes : peinture par pulvérisation et oxydation Surface du tissu : PU, UV, imperméable
Type de mur applicable	Murs en béton armé, murs en briques et murs en bois
Hauteur d'installation recommandée	2.5m-4m 8'-13'
Conditions météorologiques applicables	Les produits sont utilisés pour protéger du soleil. Applicable lorsque le vent est inférieur à 5. Ne convient pas au temps pluvieux.

Montage mural

Notes sur le montage mural



Cet auvent peut être fixé à des murs en béton armé, en brique et en bois.

Toutefois, ce kit d'auvent fournit uniquement des vis adaptées au montage sur des murs en brique et en béton armé.

Si vous souhaitez fixer votre auvent à du bois, veuillez utiliser des vis à bois de longueur et de diamètre appropriés pour fixer l'auvent à des poutres en bois.

La taille de la vis dépend de la taille du bois ; ces vis peuvent être achetées dans une quincaillerie. Nous recommandons de faire appel à un installateur professionnel pour une installation la plus sûre et la plus sécurisée possible.

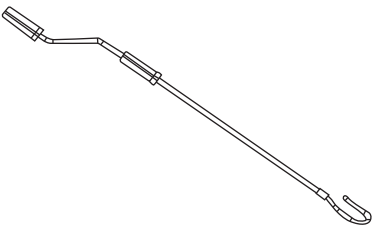
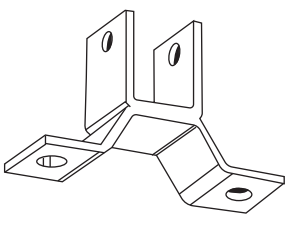
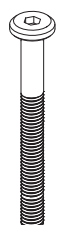
N'essayez jamais de fixer les supports muraux sur des pierres murales instables ou sur toute autre surface qui n'est pas ferme !

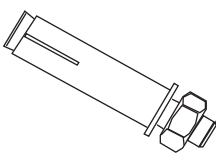
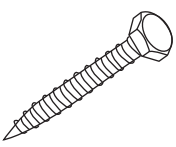
I  1pc	J  2pcs	P2  M8x55 2pcs	
Q  M8 2pcs	V  M8 2pcs	S  4pcs	Z  M10x72 4pcs

! ATTENTION

Le positionnement correct des supports est l'aspect le plus important de l'installation de l'auvent. Il est essentiel que vous fixiez tous les supports de montage aux montants, solives, linteaux ou autres éléments structurels majeurs.

! AVERTISSEMENT

Si tous les supports ne sont pas solidement fixés au mur, l'auvent risque de s'effondrer et de provoquer des blessures corporelles ou la mort.

Hauteur de montage

Il est important de tenir compte de la zone de chute de l'auvent avant de fixer vos supports muraux. Si vous souhaitez installer votre auvent au-dessus d'une porte-fenêtre, par exemple, laissez au moins 20,5 cm au-dessus du cadre de la porte et assurez-vous que l'auvent ne gêne pas l'ouverture et la fermeture de la porte. L'angle de chute ne peut être modifié que de façon minimale, alors tenez-en compte lorsque vous décidez de l'emplacement de votre auvent.

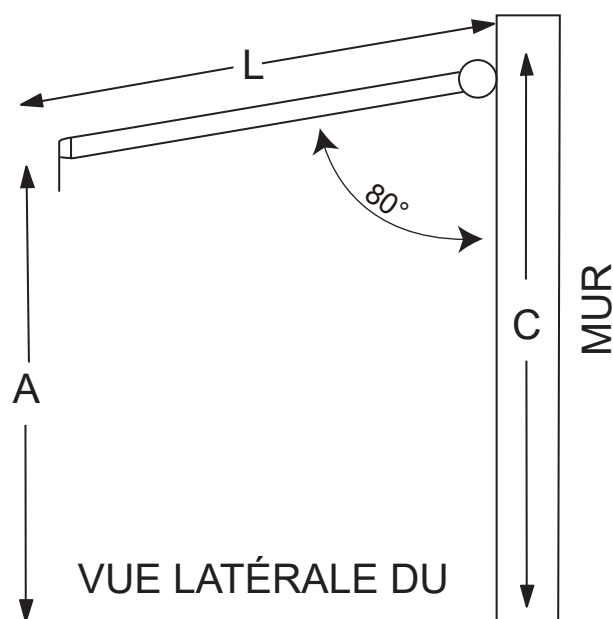

Hauteur d'installation recommandée : 2,5 à 4 m. L'angle de chute idéal (lorsque le bras est complètement déployé) a déjà été réglé en usine, vous n'aurez donc peut-être pas à modifier l'inclinaison/l'angle.
CALCULS :
Vous pouvez utiliser la formule suivante pour calculer l'angle approprié.

$$C = A + 0,17 \times L$$

A = La hauteur souhaitée de la barre avant

L = La longueur du bras tendu

C = La hauteur des supports muraux

Nous recommandons que la surface du store fasse un angle d'environ 80 degrés par rapport au mur lorsqu'il est ouvert.

Étape 1

Mesurer l'emplacement

1. Mesurez la longueur de votre store le long du mur où vous souhaitez l'installer. Cette ligne sera le point le plus haut de votre store et s'alignera avec le haut du support mural. Utilisez un niveau pour tracer une ligne à la craie.
2. Important : vérifiez à nouveau que la ligne est droite sur toute sa longueur.
3. Veillez à ce que la ligne soit centrée sur la porte-fenêtre, la fenêtre ou autre menuiserie le cas échéant.
4. Maintenant que vous avez une ligne droite et centrée, mesurez le point du milieu et marquez-le. C'est là que le centre du support mural sera installé.
5. Prenez un support mural et placez le haut de celui-ci, bien droit, sous la ligne, comme indiqué dans la figure ci-dessous. Marquez la position de tous les supports muraux et leurs trous pour les boulons avec une craie ou un crayon. Veuillez noter que la distance entre chaque support mural doit être la même.

Auvent < 10,8'(3,5m)	Nécessite seulement 2 supports muraux au total : un pour chaque extrémité de la tige du tube de support.
Auvent = 10,8-14'(3,5-4m)	Nécessite 3 supports muraux au total : un pour chaque extrémité et un au milieu.

La distance entre l'avant-toit et le support mural est de 23,9"(10cm)

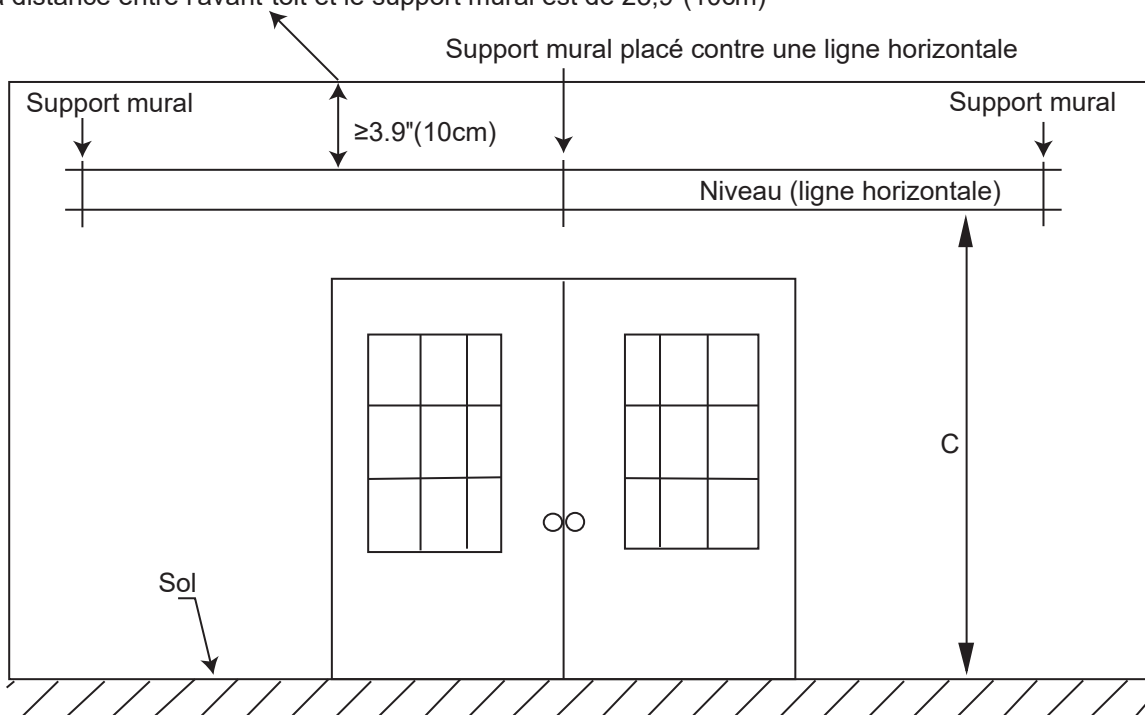

Étape 2

Perçage des trous pour les boulons

1. Maintenant que vous avez une ligne droite le long du mur avec les emplacements des supports muraux et leurs trous de fixation marqués, vous pouvez percer des trous pour monter les supports.

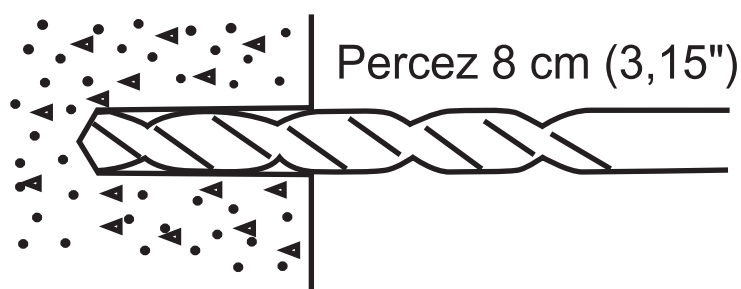

2. A l'aide d'une mèche de 14 mm, percez le premier trou de boulon à une profondeur d'environ 8 cm, comme indiqué sur la figure. Ce trou doit être percé à travers une brique solide ou du béton pour offrir le support nécessaire à l'auvent.
3. Percez les autres trous exactement comme à l'étape 2.

⚠ AVERTISSEMENT

Tous les trous des boulons doivent être alignés verticalement et horizontalement pour assurer la suspension de l'auvent droit.
Vérifiez à nouveau l'alignement avant de percer si vous n'êtes pas sûr.

⚠ AVERTISSEMENT

Le diamètre et la profondeur des trous de montage doivent être de la même taille que les boulons d'expansion.

Étape 3

Préparation au montage

1. Maintenant que tous les trous sont percés, insérez les boulons.
2. Il peut être nécessaire d'enfoncer les boulons à l'aide d'un maillet en bois ou autre outil non métallique.



Si un maillet est nécessaire pour l'installation, nous recommandons de placer l'écrou sur la vis (sans le serrer) avant de marteler pour éviter d'endommager le filetage du boulon.

3. Veillez à ce que les boulons soient bien en place, et laissez-les dépasser du mur d'environ 1 pouce (2,5cm) ou moins suffisamment pour que le support mural puisse être installé dessus.

Serrez fermement les boulons à l'aide d'une clé hexagonale de 0,75"(19mm). Il est préférable d'utiliser la clé hexagonale avec une extrémité fermée plutôt qu'une extrémité ouverte afin d'éviter d'endommager l'écrou s'il venait à glisser.

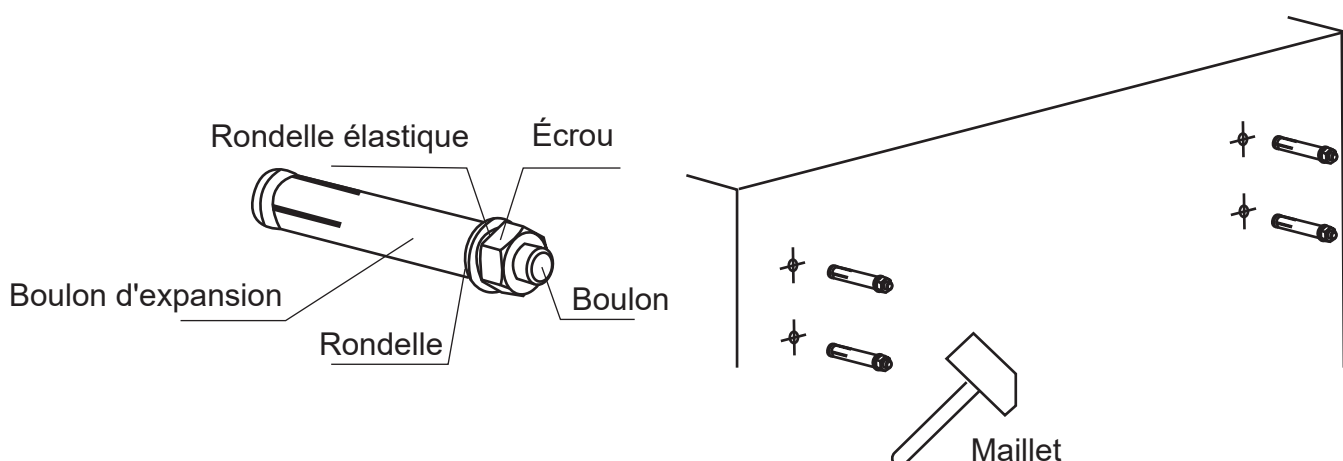

Étape 4

Montage des supports muraux

1. Maintenant que les boulons sont solidement installés sur le mur, retirez les écrous qui sont mal placés sur les boulons.
2. Placez un support mural sur un jeu de boulons. L'ajustement devrait être facile si les trous des boulons sont correctement alignés.
3. Une fois que le support mural repose sur les boulons, placez une rondelle sur le boulon. Fixez-le ensuite à l'aide d'un écrou, comme indiqué sur la figure.

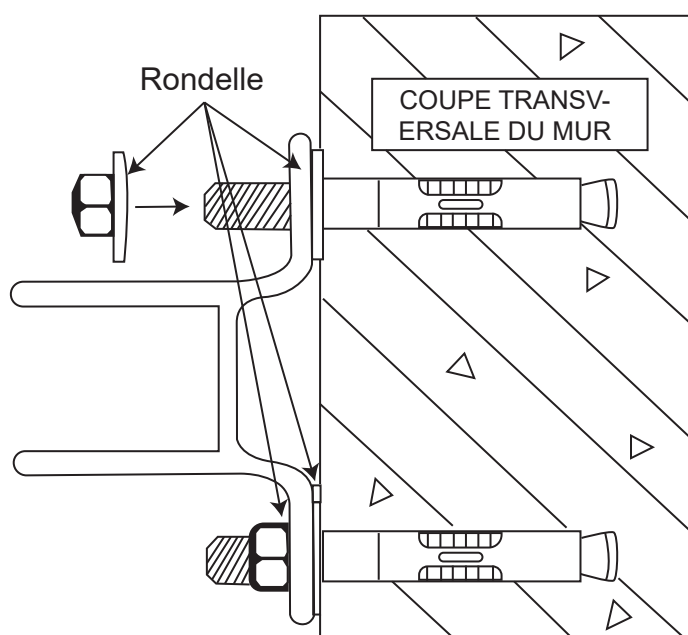

4. Les supports **DOIVENT** être solidement fixés au mur. S'ils bougent, vous devez les serrer davantage.
5. Répétez cette étape pour chacun des supports muraux. Une fois cette opération effectuée, tous les supports muraux seront solidement installés en place.

Étape 5

Montage de l'auvent

1. Maintenant que les supports muraux sont fixés et en place, il est temps d'installer l'auvent sur les supports.
2. Mettez la tige du tube de support (sur les supports muraux et serrez-les avec les vis hexagonales)(.)
3. Enfin, fixer tous les boulons d'expansion.
4. A l'aide de la manivelle ou d'un moteur (le cas échéant), ouvrez complètement votre auvent. La barre avant doit être droite.
5. Félicitations ! Votre auvent est installé. Si vous êtes satisfait de la hauteur de la barre avant (inclinaison de l'auvent), asseyez-vous et profitez ! Si ce n'est pas le cas, lisez la suite.

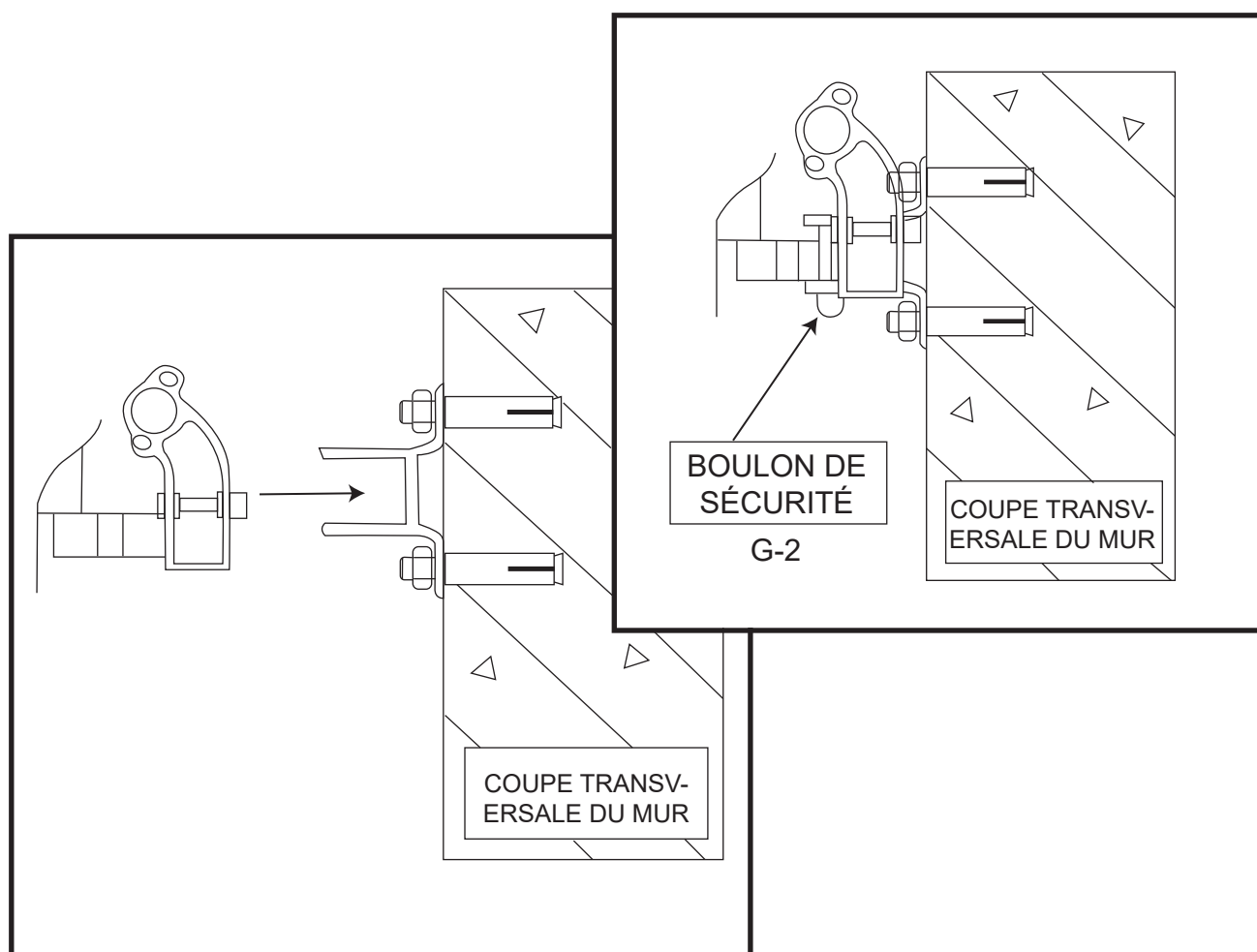

INSTALLATION OPTIONNELLE

Réglage de l'auvent

Chaque store est livré avec un angle prédéfini qui est considéré comme idéal. Cependant, si vous devez faire un ajustement, cela peut être fait en quelques étapes faciles.

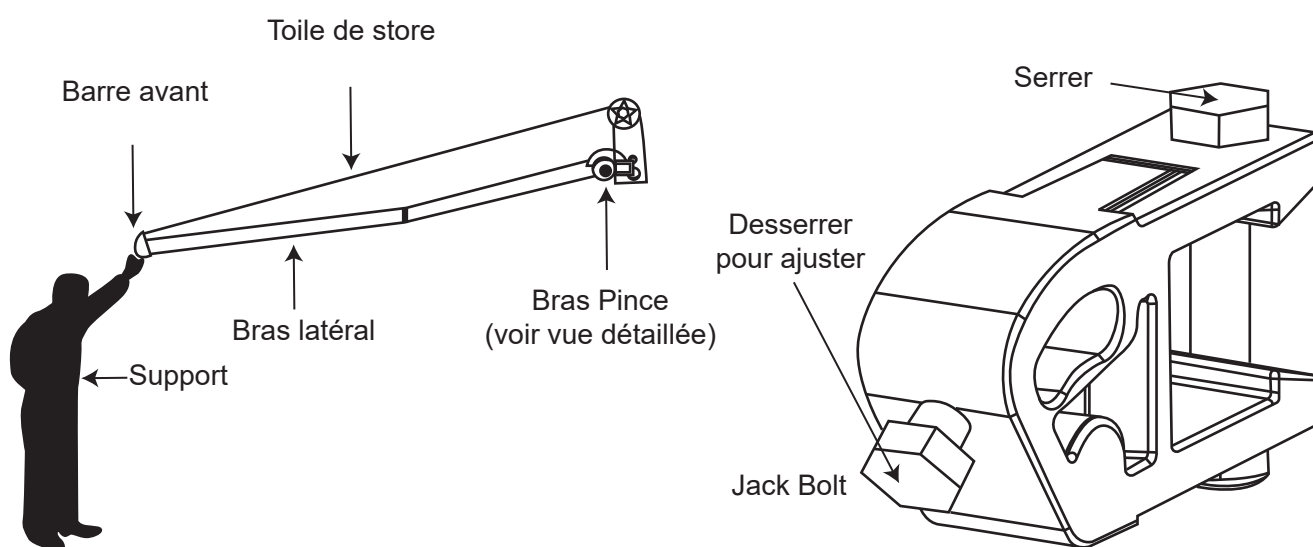

⚠ AVERTISSEMENT

Monter la barre avant réduira l'angle de la toile, augmentant ainsi le risque d'accumulation d'eau de pluie sur la toile. Pour éviter que l'auvent ne s'affaisse à cause de l'eau de pluie du poids, vous devez rétracter l'auvent lorsqu'il est utilisé sans surveillance. Le non-respect de cette consigne peut entraîner une rupture de l'auvent ou des blessures corporelles.

Remarque : assurez-vous que la barre avant est réglée pour être complètement alignée. Tout désalignement entraînera une rétraction incorrecte.

ERREURS COURANTES

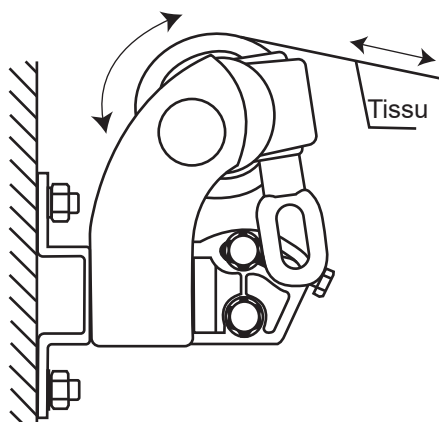

Fonctionnement correct

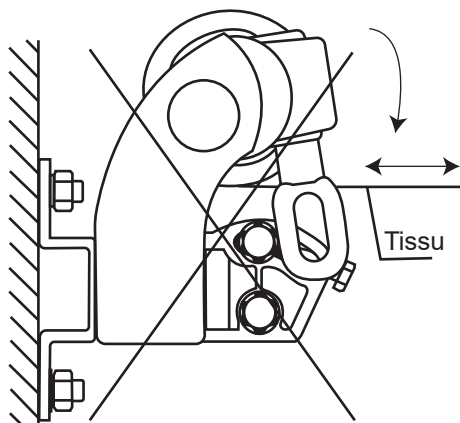

Fonctionnement incorrect

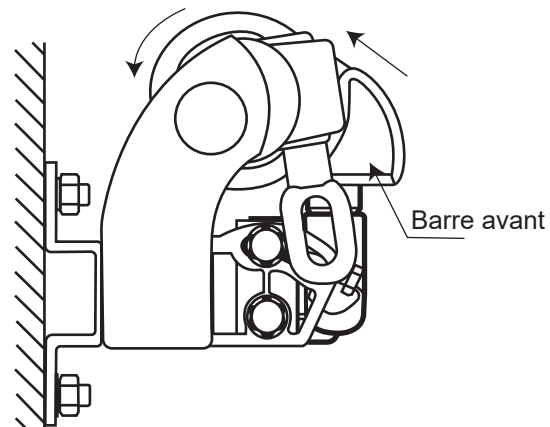

AVERTISSEMENT

Lorsque la barre frontale touche le rouleau comme indiqué sur le schéma, n'essayez pas de les rapprocher, sinon le produit risque d'être endommagé.

Personne de contact
Made4Home SAS
137 av. Gustave Eiffel
ZI Rognac Nord
13340 Rognac (France)
téléphone au: +33 4 42 81 81 80
www.tectake.fr
E-Mail: contact@tectake.fr

Instrucciones de montaje del toldo

3x2.5M 2.5x2M

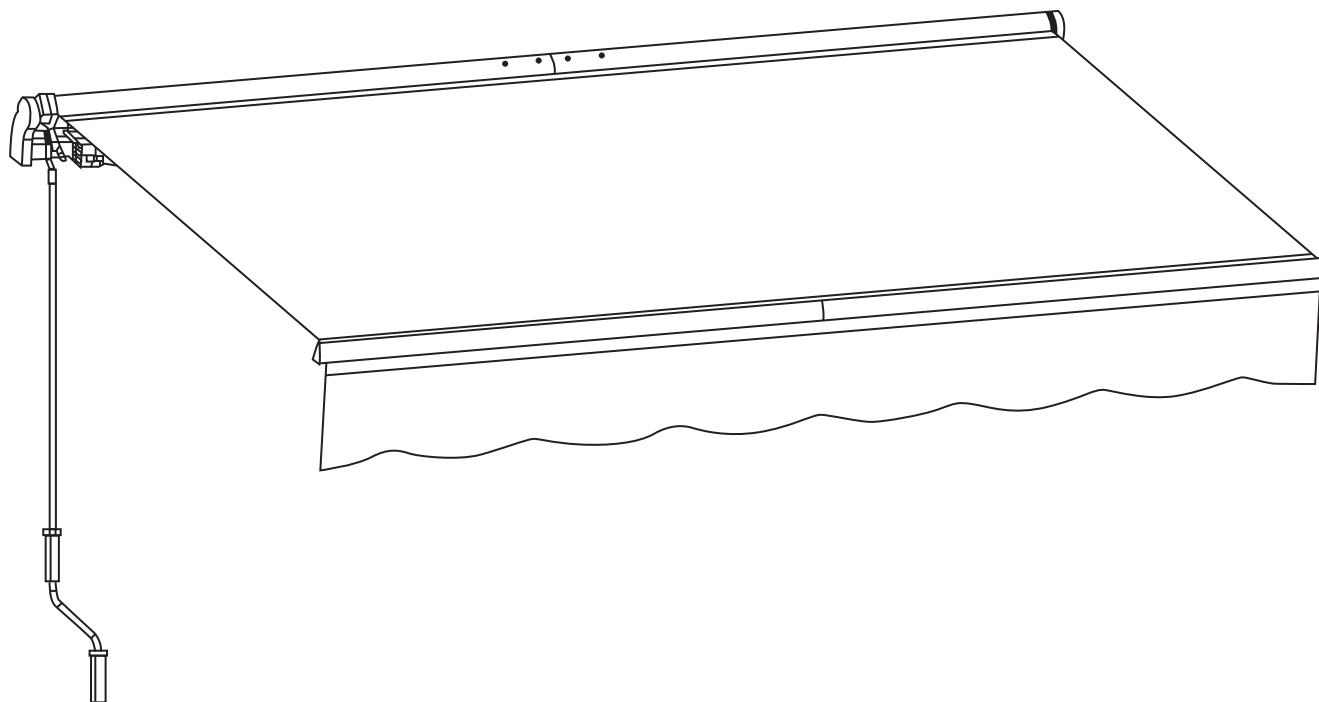

¡Gracias por comprar nuestro toldo retráctil! Esperamos que disfrute de nuestro producto durante muchos años.







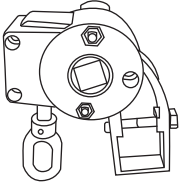
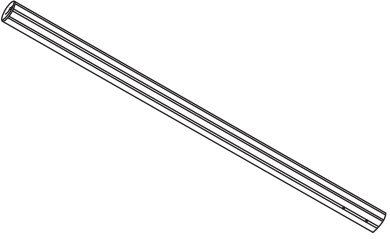
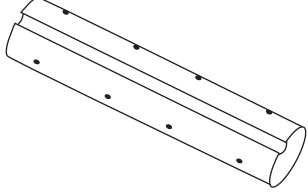
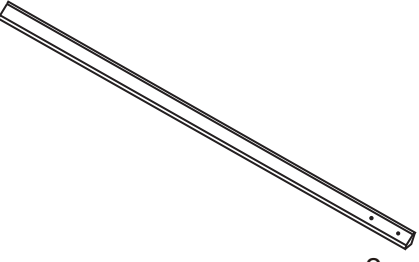
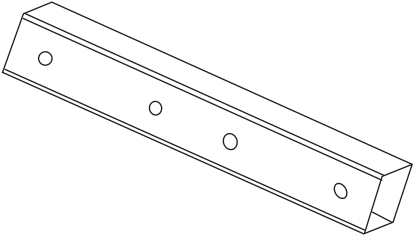
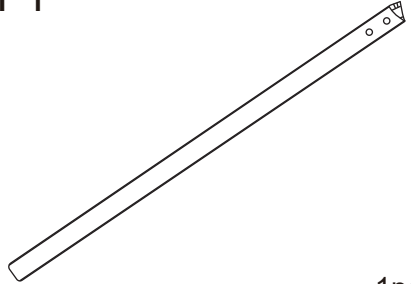
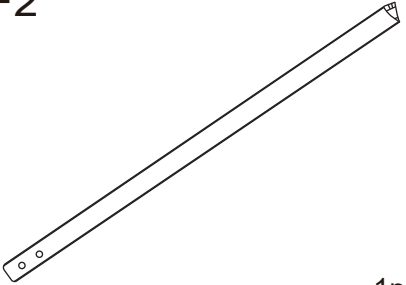
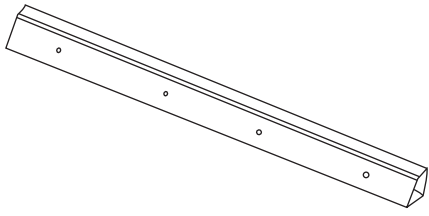
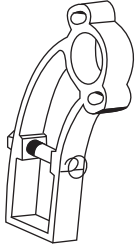
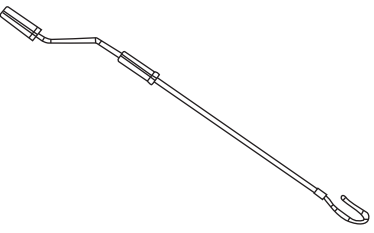
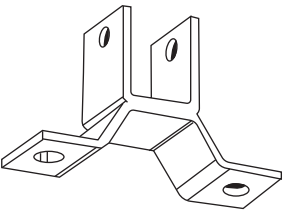
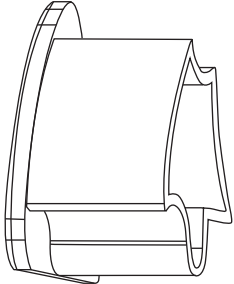
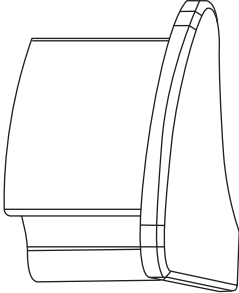
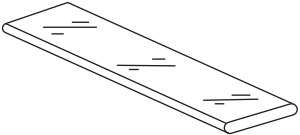
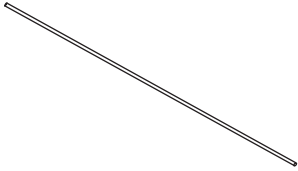

Para garantizar su seguridad durante la instalación y aprovechar al máximo su compra, le recomendamos leer completamente este manual antes de comenzar el proceso de instalación.

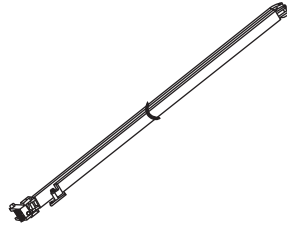
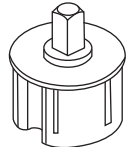
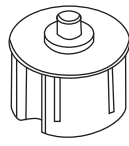
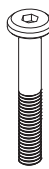
Sugerimos que dos personas realicen la instalación del toldo. Si considera que este proceso es demasiado difícil de hacer por su cuenta, le aconsejamos buscar ayuda de un contratista local de construcción o mejoras para el hogar.

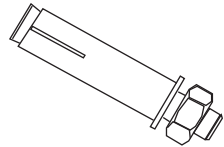

Si tiene algún problema o necesita asistencia durante el ensamblaje, si faltan piezas o están defectuosas, o si surge cualquier otra cuestión, comuníquese con nuestro departamento de atención al cliente. Nos esforzaremos en ayudarlo a resolver sus problemas.

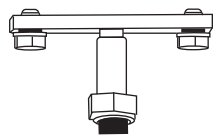
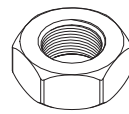
**Lista de piezas:
Instalación opcional**

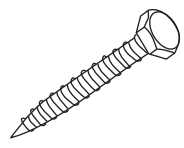
<p>A</p>  <p>1pc</p>	<p>B</p>  <p>2pcs</p>	<p>C</p>  <p>1pc</p>
<p>D</p>  <p>2pcs</p>	<p>E</p>  <p>1pc</p>	<p>F1</p>  <p>1pc</p>
<p>F2</p>  <p>1pc</p>	<p>G</p>  <p>1pc</p>	<p>H</p>  <p>1pc</p>
<p>I</p>  <p>1pc</p>	<p>J</p>  <p>2pcs</p>	<p>K1</p>  <p>1pc</p>
<p>K2</p>  <p>1pc</p>	<p>L</p>  <p>1pc</p>	<p>M</p>  <p>3pcs</p>

<p>N1</p>  <p>1pc</p>	<p>N2</p>  <p>1pc</p>	<p>O1</p>  <p>1pc</p>	
<p>O2</p>  <p>1pc</p>	<p>P1</p>  <p>M6x40 4pcs</p>	<p>P2</p>  <p>M8x55 2pcs</p>	<p>Q</p>  <p>M8 2pcs</p>
<p>R</p>  <p>M6 4pcs</p>	<p>S</p>  <p>4pcs</p>	<p>T</p>  <p>M5x16 16pcs</p>	<p>U</p>  <p>2pcs</p>
<p>V</p>  <p>M8 2pcs</p>	<p>W</p>  <p>2pcs</p>	<p>X</p>  <p>M3x10 2pcs</p>	<p>Z</p>  <p>M10x72 4pcs</p>

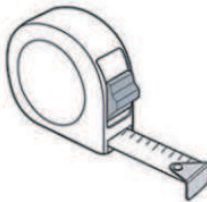
Por favor, prepare las herramientas enumeradas a continuación antes del montaje (no incluidas).

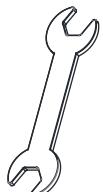
<p>Cinta métrica</p>	<p>Martillo no metálico</p>	<p>Llave (llaves de M17 y M14)</p>
		

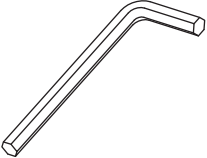
Destornillador de estrella	Taladro eléctrico con broca de 14 mm	Nivel de línea de tiza o nivel de agua	Llave de 8 mm
			

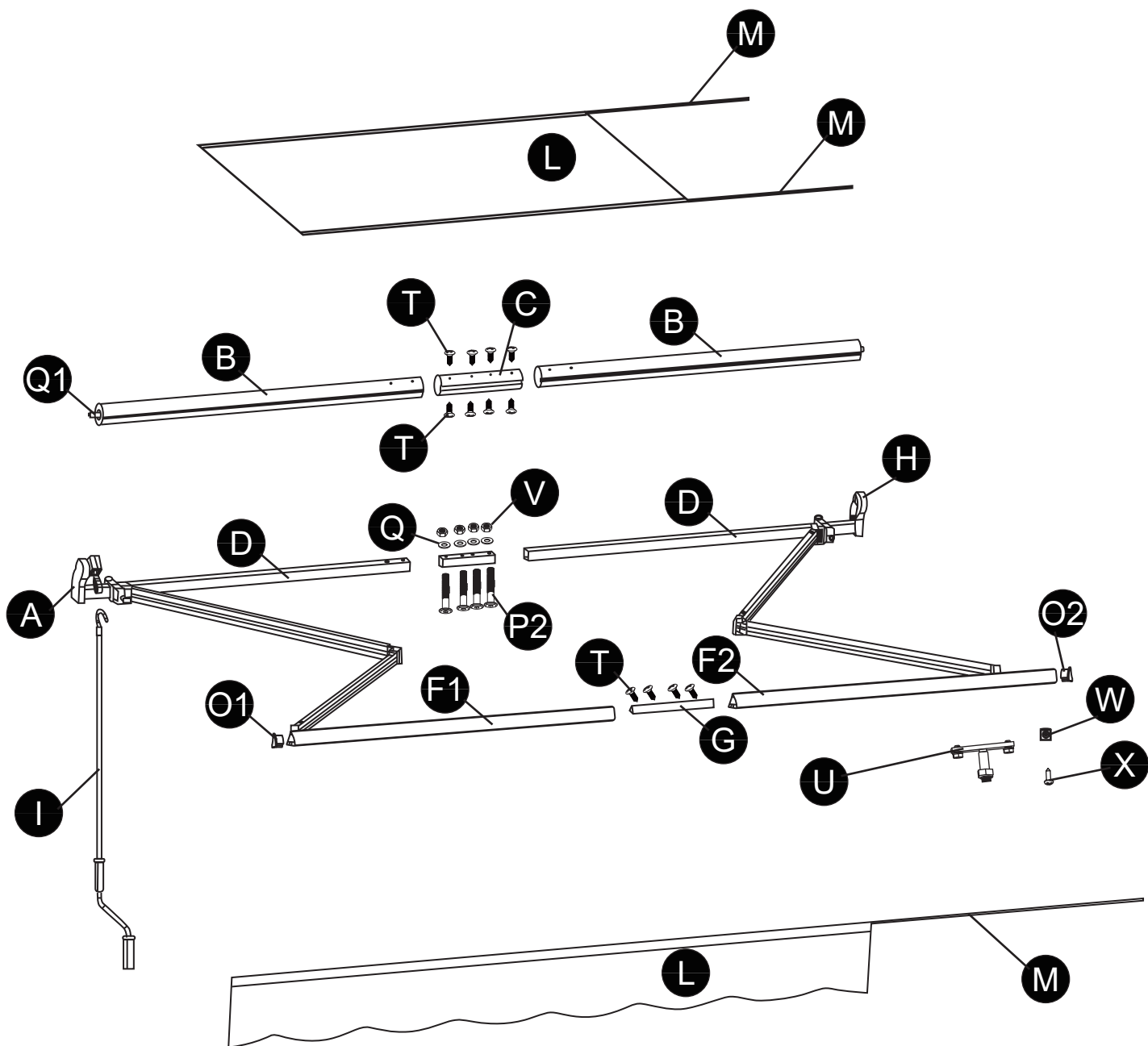

Prepare el espacio de trabajo

1. Antes de empezar, es recomendable disponer de todas las herramientas necesarias.

Consulte la sección de herramientas requeridas para ver la lista completa.

ADVERTENCIA

No retire la banda de seguridad que mantiene sujetos los brazos del toldo. Retirla demasiado pronto puede causar lesiones graves.

2. Abra la caja del toldo y retire cada pieza con cuidado para evitar daños en el producto.

3. Organice todas las piezas del toldo para asegurarse de que estén todas. Consulte el diagrama de piezas para obtener información detallada.

4. Abra la caja pequeña interior que contiene las piezas pequeñas y colóquelas ordenadamente.

Montaje:

Paso 1: Montaje del rodillo

Mantenga los rodillos alineados, ensamble el rodillo con los conectores y asegúrelo con los pernos correspondientes, como se muestra en las figuras a continuación:

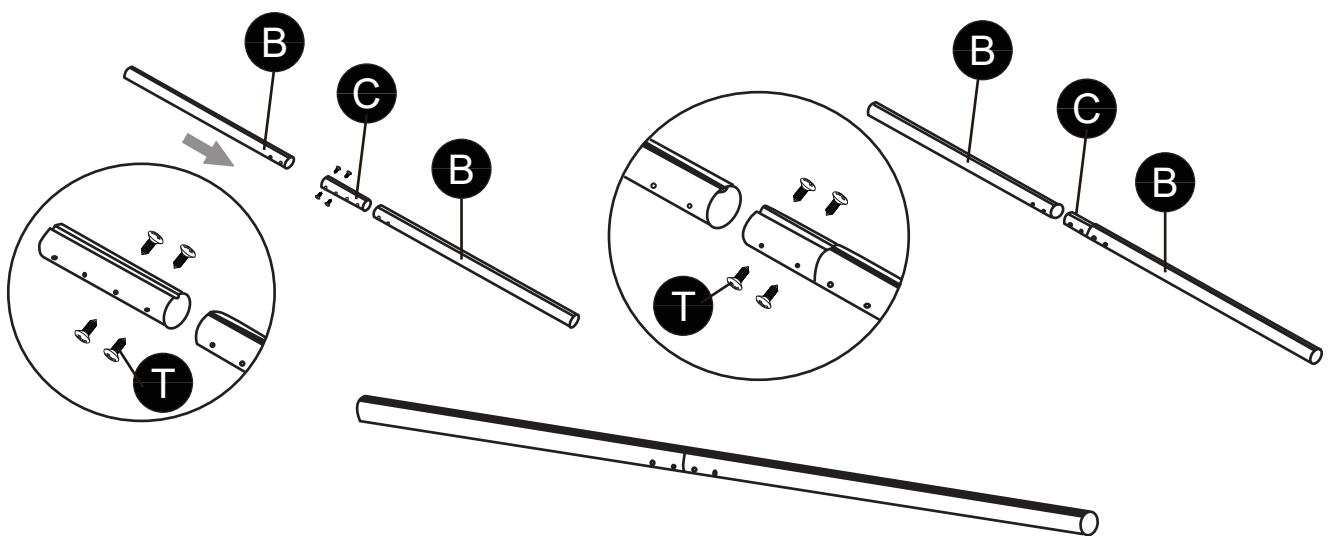

Paso 2: Montaje del tubo de soporte y los brazos

Alinee los cuatro lados, conecte los tubos de soporte con los conectores y asegúrelos con los pernos correspondientes, como se muestra en las figuras a continuación:

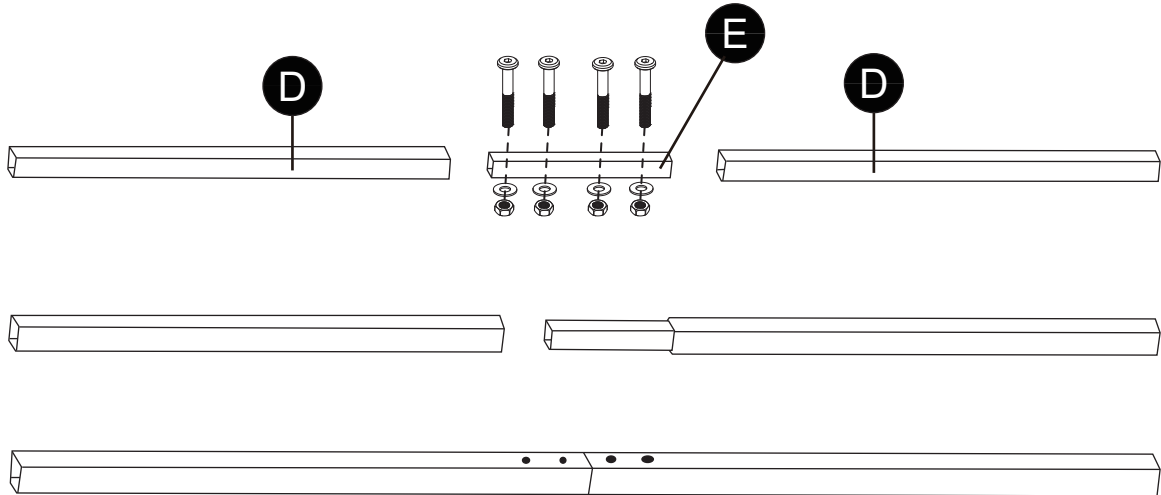

Luego, ensamble los brazos a los tubos de soporte como se muestra en las figuras a continuación. Los dos brazos deben estar apuntando en la misma dirección. El cable del brazo no debe ser desbloqueado hasta que el ensamblaje esté completo.

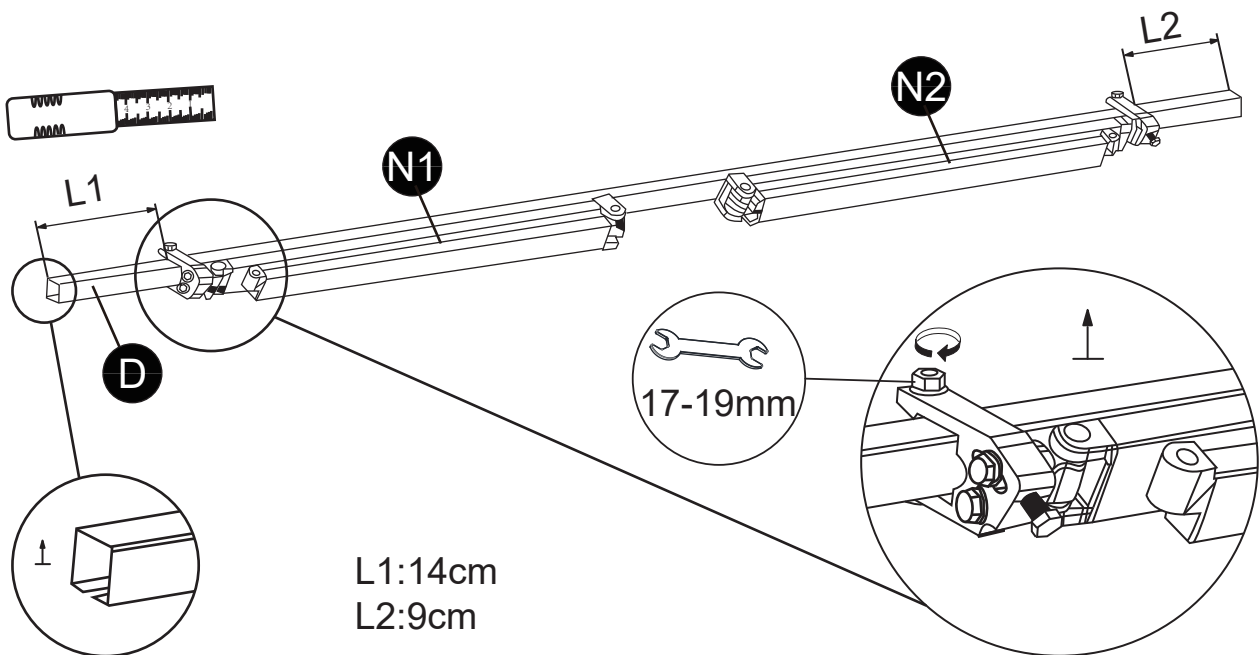

Paso 3: Montaje de la barra frontal

Conecte la barra frontal con los conectores (pos. 7) y asegúrela con los pernos correspondientes, como se muestra en las figuras a continuación (mantenga la barra frontal alineada).

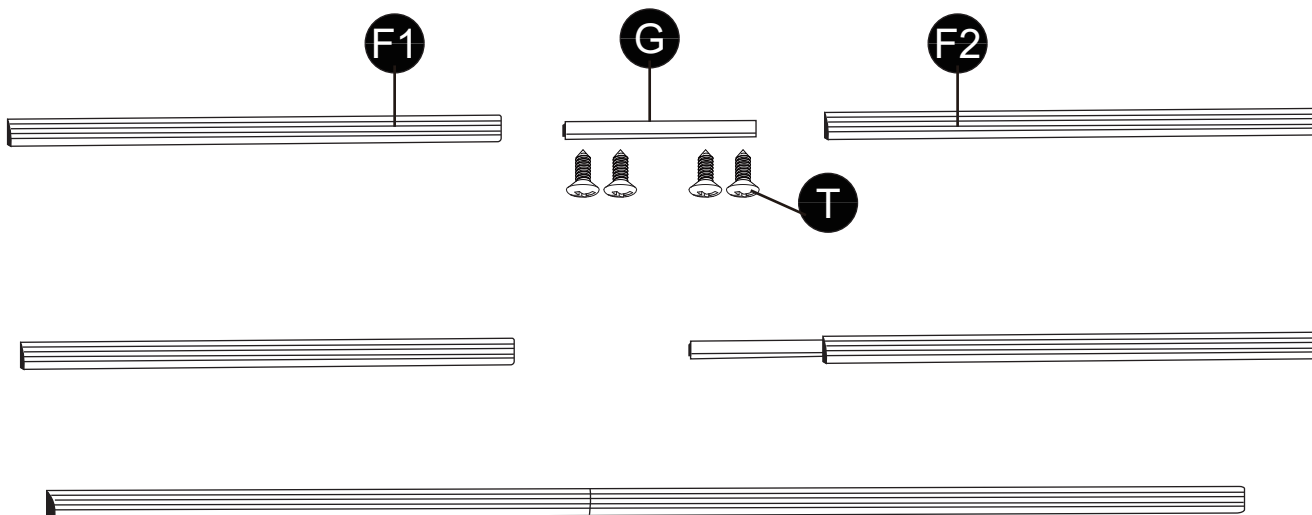

Paso 4: Montaje del soporte de muñeca de la barra frontal

Deslice los pies (pos. 18) en la barra frontal sin apretarlos. Como se muestra en la figura a continuación:



Paso 5: Montaje de los brazos con la barra frontal

Coloque el perno de los pies de la barra frontal (pos. 18) a través del agujero del brazo pequeño, luego coloque la barra frontal. Después de posicionarla, apriete la tuerca con una llave, como se muestra en la figura a continuación:

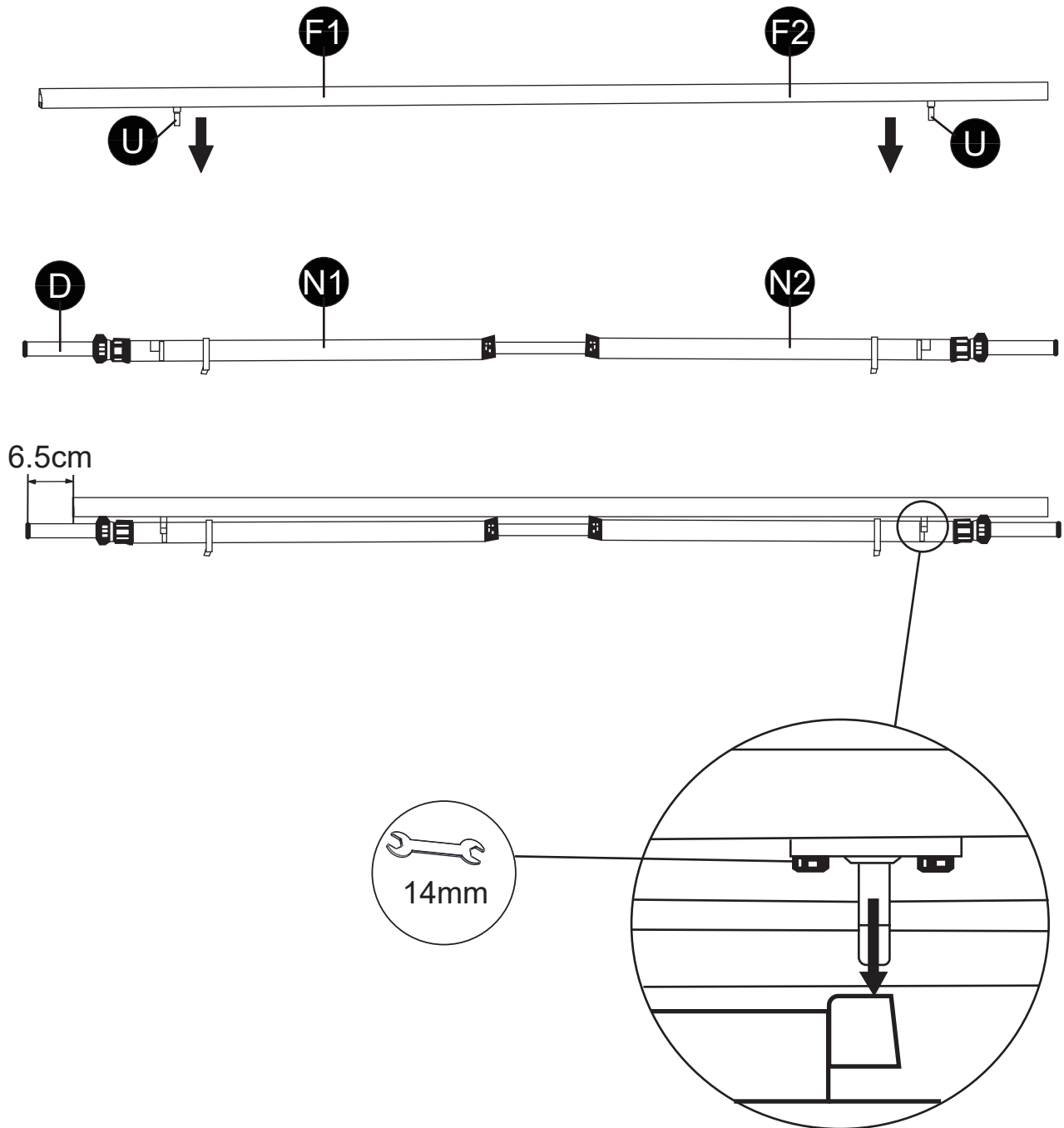

Paso 6: Colocar la tuerca autoblocante

Coloque las tuercas autoblocantes en los tornillos ubicados en la parte inferior de los pies y apriételas firmemente con una llave, como se muestra en la figura a continuación:

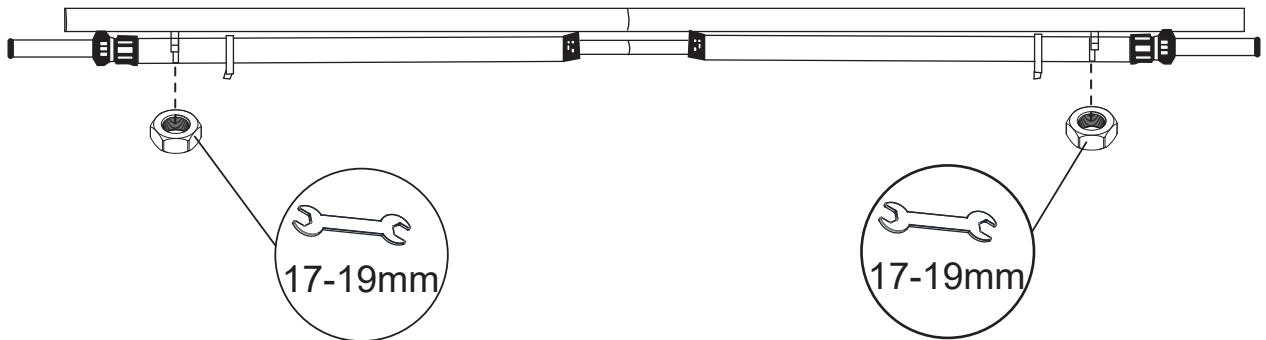

ATENCIÓN: ANTES DE APRETAR LAS TUERCAS, ASEGÚRESE DE QUE LOS BRAZOS ESTÉN CORRECTAMENTE ALINEADOS.

Paso 7: Montaje del soporte izquierdo del rodillo con la caja de engranajes

Golpee el soporte izquierdo del rodillo con la caja de engranajes en el extremo izquierdo del tubo de soporte con un martillo, luego apriete el perno hexagonal izquierdo. Como se muestra en la figura a continuación:

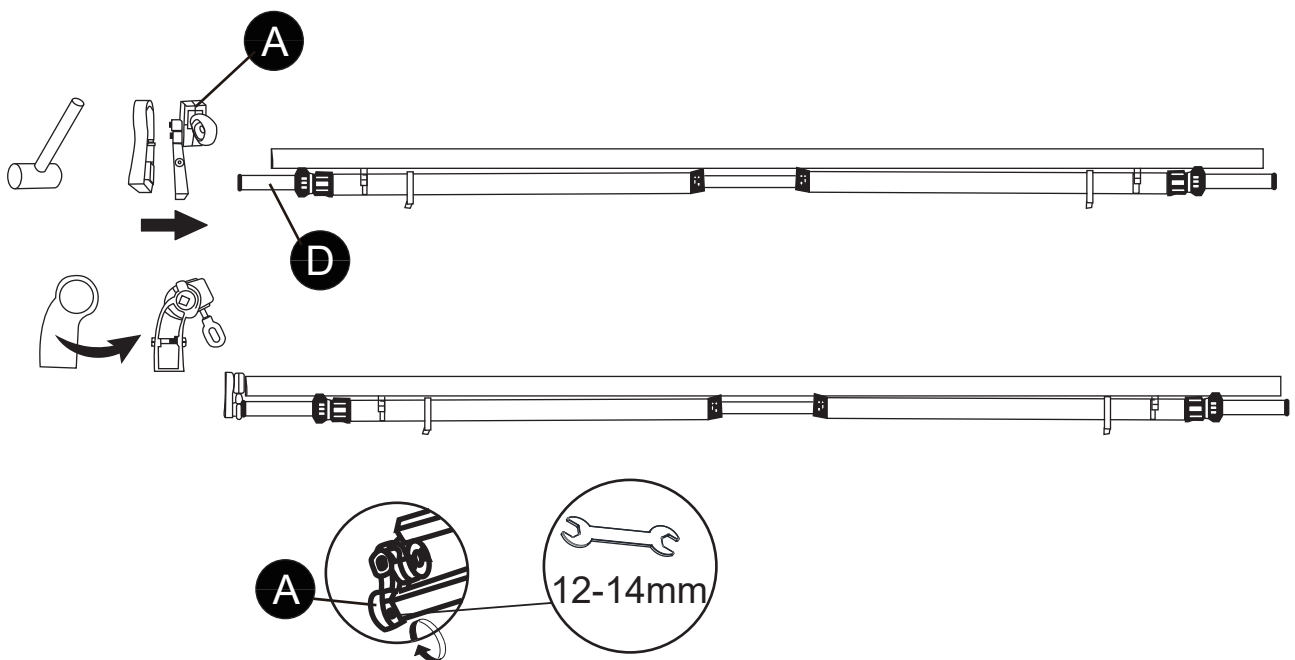

Paso 8: Montaje de la tela y el voladizo

Abra la bolsa de tela. Extienda ambas telas 14A y el voladizo 14B y use el cable guía para pasar a través de la tela. Como se muestra en la figura a continuación:

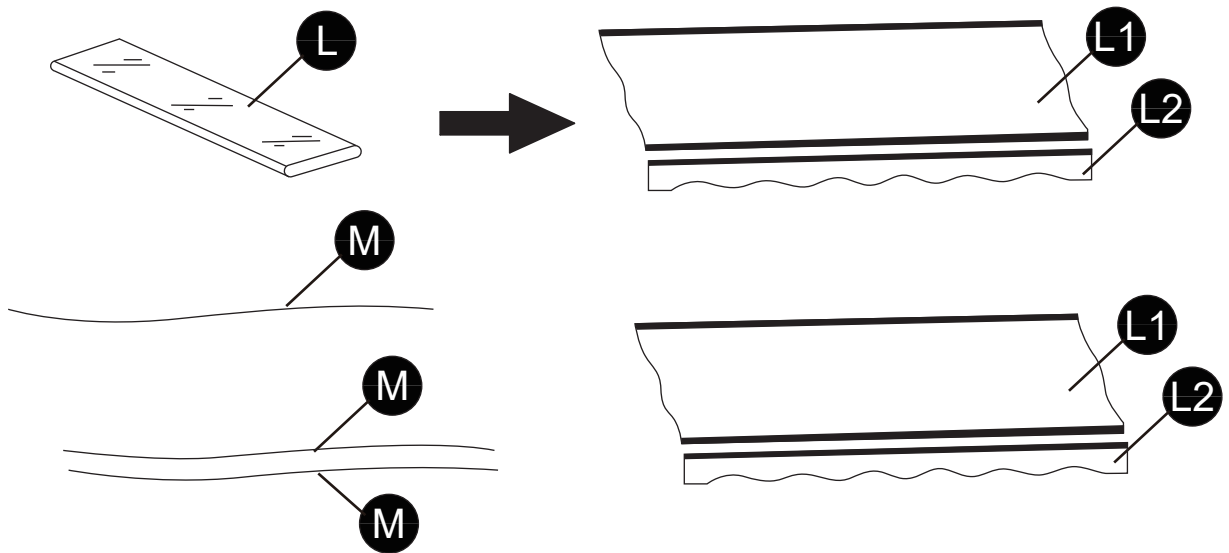

Paso 9: Enrollar la tela en el rodillo

Enrolle la tela en el rodillo, preste atención a la dirección de la tela necesaria, como se muestra en la figura a continuación:

Por favor, coloque la tela hacia arriba al ensamblar. Mantenga el mismo espacio (X) en ambos extremos.

Extienda la tela lentamente para evitar daños.

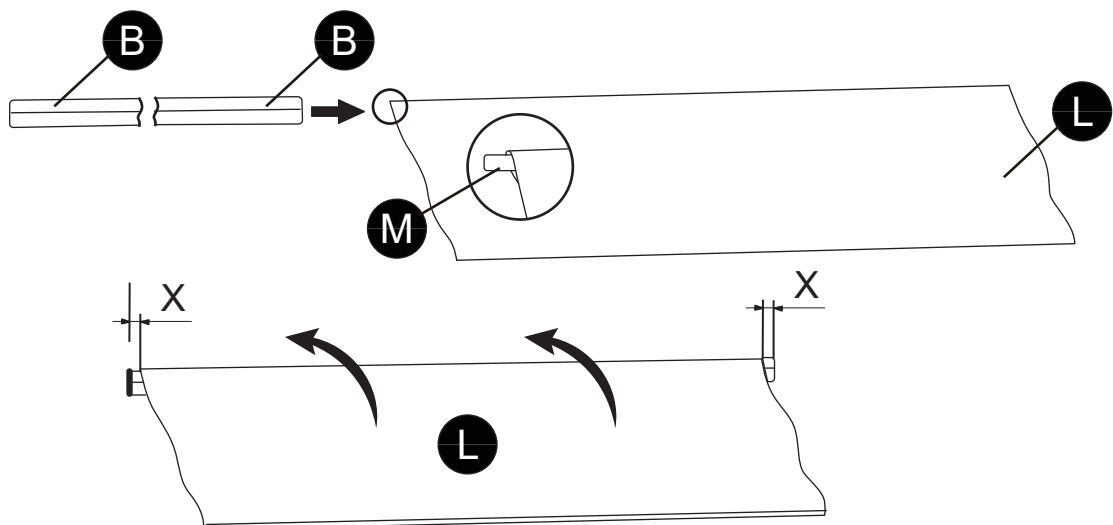

Paso 10: Instalación de la tela

Inserte un extremo de la tela a través de la ranura de la barra frontal y distribuya la tela de manera uniforme después de pasarla completamente. Luego, inserte el eje del rollo en el orificio cuadrado de la caja de la caja de engranajes, como se muestra en la figura a continuación:

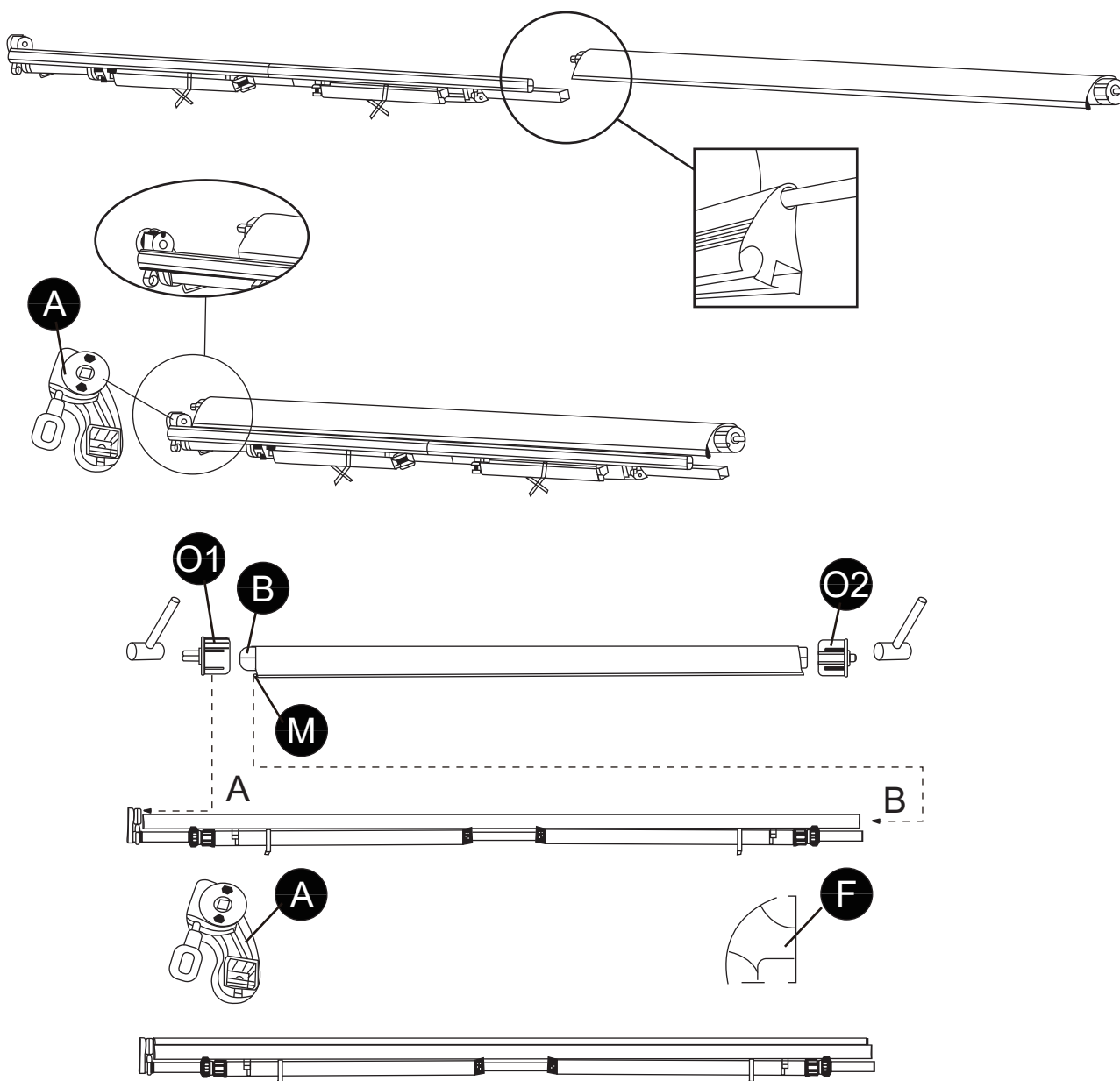

Si la parte de la barra frontal está un poco deformada, ajústela con herramientas por su cuenta.

Paso 11: Montaje del soporte derecho del rodillo

Inserte el eje del rollo en la tapa del tubo del rodillo mientras guía el tubo de soporte hacia el soporte del rodillo derecho, golpeándolo para ajustarlo. Luego, apriete el tornillo hexagonal derecho con una llave de 5 mm, como se muestra en la figura a continuación:

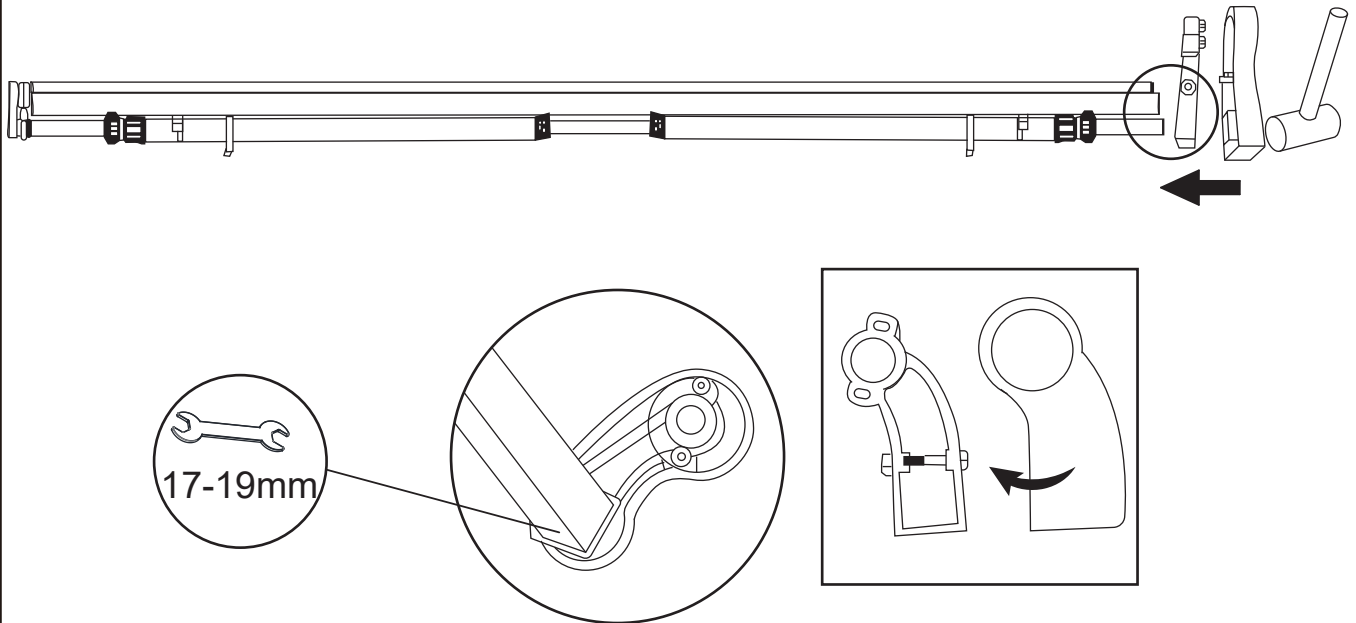

Paso 12: Ensamblar para formar el toldo complete

Inserte el voladizo a través de la ranura de la barra frontal, asegurándose de que la dirección sea correcta y que esté alineado uniformemente en ambos lados (izquierda y derecha). Luego, use un martillo para colocar la tapa de la barra frontal en el extremo de la barra frontal, como se muestra en la figura a continuación:

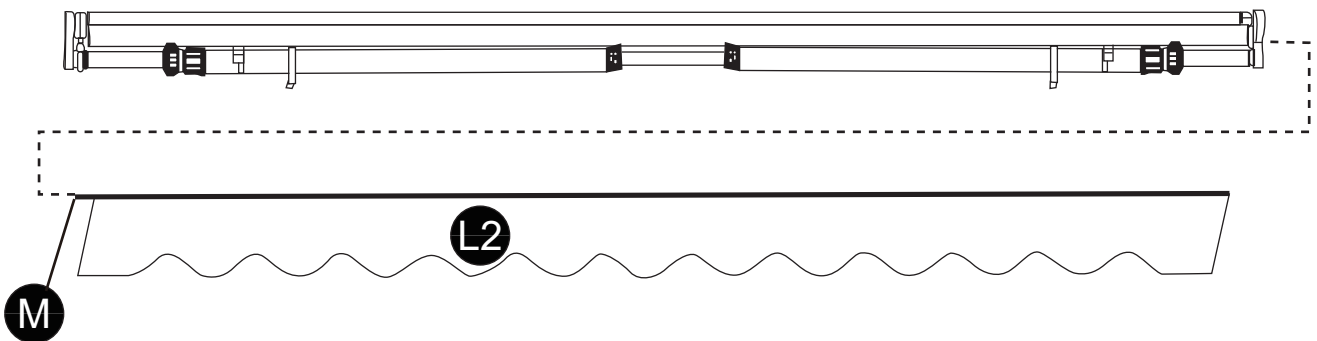

Si la parte de la barra frontal está un poco deformada, ajústela con herramientas por su cuenta.

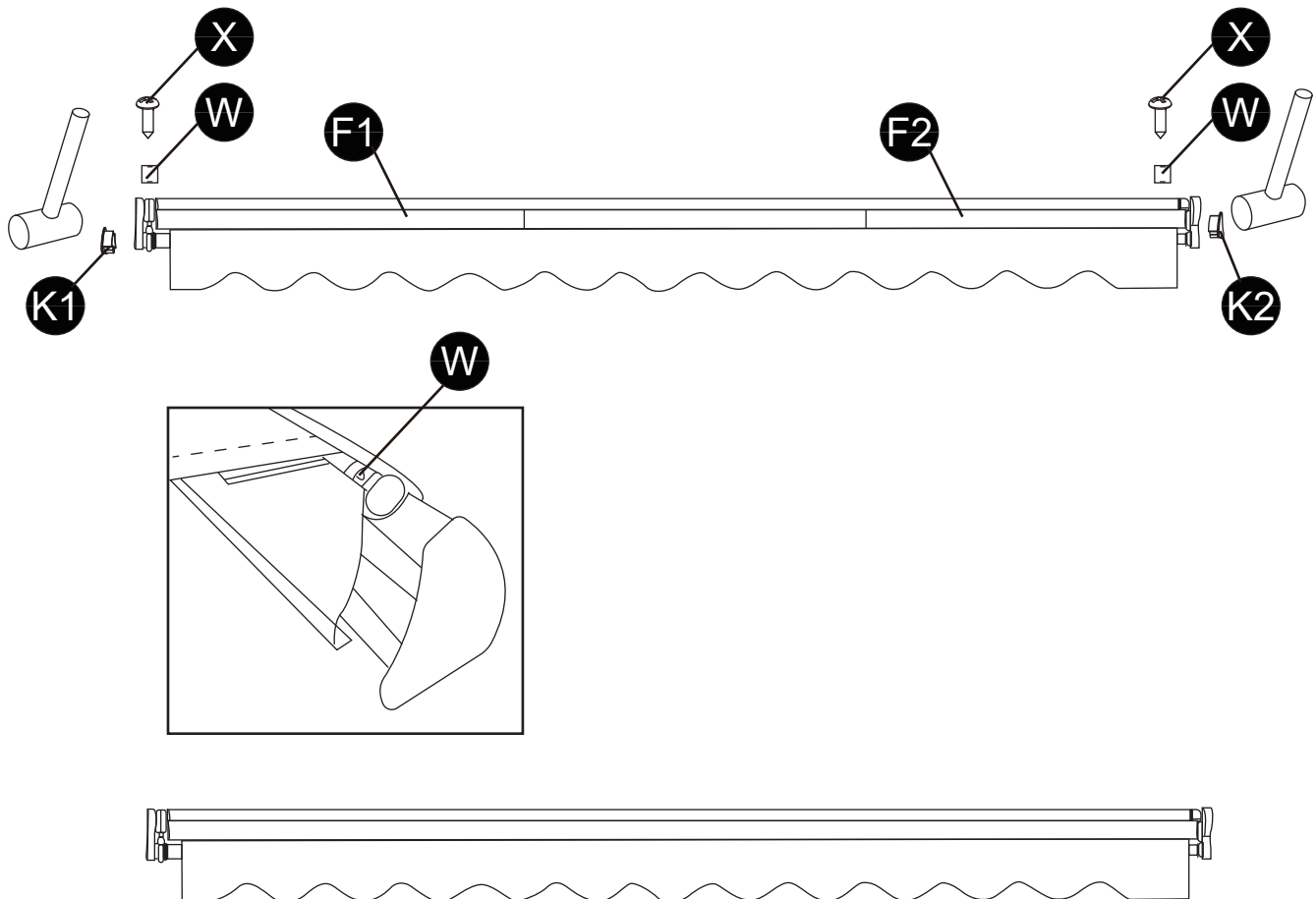

Si encuentra que la tela se enrolla de manera desigual o que los dos brazos no se abren al mismo tiempo, observe la estabilidad de los dos brazos. Solución: Ajuste la posición del conector de la barra del brazo en la barra frontal hacia afuera si es necesario.

Especificaciones



Nombre del producto	Toldo retráctil (Consulte los detalles en el paquete)
Material y tratamiento de superficie	Materiales: Tubo de acero, aleación de aluminio, piezas plásticas, tela de poliéster. Tratamiento de servicio: Tuberías: pintura en aerosol y oxidación Superficie de la tela: PU, UV, repelente al agua
Tipo de pared aplicable	Paredes de concreto reforzado, paredes de ladrillo y paredes de madera
Altura de instalación recomendada	2.5m-4m 8'-13'
Clima aplicable	Los productos se utilizan para proteger del sol. Son aplicables cuando el viento es de nivel 5 o menos. No son adecuados para condiciones de lluvia.

Montaje en pared

Este toldo puede ser fijado a paredes de concreto reforzado, ladrillo y madera. Sin embargo, este kit de toldo solo incluye tornillos adecuados para el montaje en paredes de ladrillo y concreto reforzado.

Si desea fijar su toldo a madera, utilice tornillos para madera de longitud adecuada y de un diámetro apropiado para asegurar el toldo a las vigas de madera. El tamaño del perno depende del tamaño de la madera; estos pueden ser adquiridos en una ferretería. Recomendamos contratar a un instalador profesional para una instalación más segura y firme.

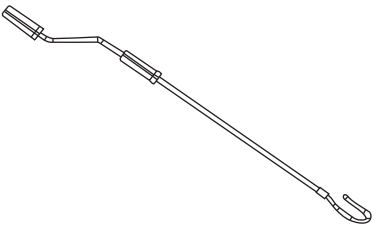
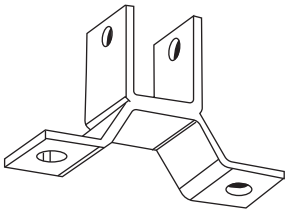
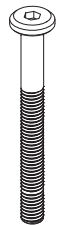
¡Nunca intente fijar los soportes de pared a piedras sueltas de la pared o superficies que no sean firmes!

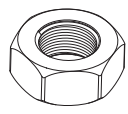
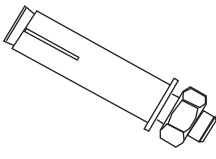
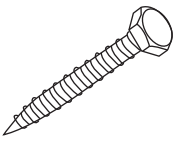
I  1pc	J  2pcs	P2  M8x55 2pcs	
Q  M8 2pcs	V  M8 2pcs	S  4pcs	Z  M10x72 4pcs

! PRECAUCIÓN

La ubicación adecuada de los soportes es el aspecto más importante en la instalación del toldo. Es crucial que fije todos los soportes de montaje a las vigas, viguetas, cabezales u otros componentes estructurales principales.

! ADVERTENCIA

No fijar adecuadamente todos los soportes a la pared podría resultar en el colapso del toldo y causar lesiones personales o incluso la muerte.

Altura de montaje

Es importante tener en cuenta el área de caída del toldo antes de fijar los montajes en la pared. Si desea montarlo sobre una puerta de patio, por ejemplo, deje al menos 8" (20,5 cm) sobre el marco de la puerta y asegúrese de que el toldo no interfiera con la apertura y cierre de la puerta. El ángulo de caída solo puede ajustarse mínimamente, por lo que debe tener esto en cuenta al decidir dónde colocar su toldo.

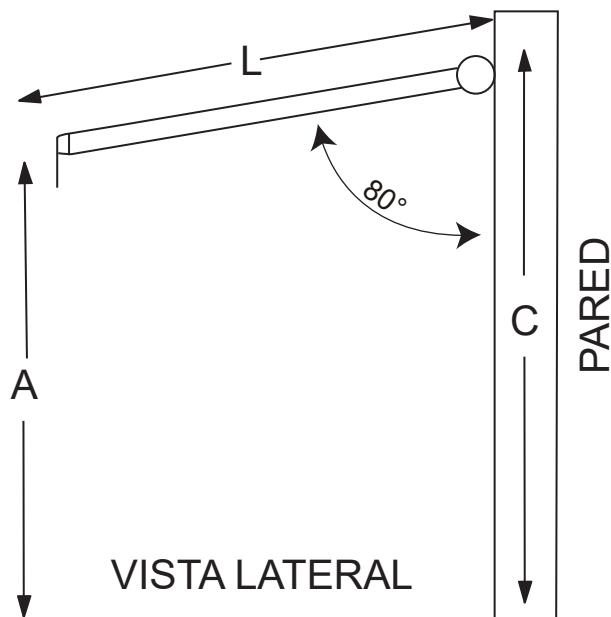

Altura de instalación recomendada: 8 - 13' (2.5 - 4 m). El ángulo de caída ideal (cuando está completamente extendido) ya ha sido ajustado en fábrica, por lo que es posible que no sea necesario cambiar la inclinación/ángulo.

CÁLCULOS:

Puede usar la siguiente fórmula para calcular el ángulo apropiado.

$$C = A + 0.17 * L$$

A = La altura deseada de la barra frontal

L = La longitud del brazo estirado

C = La altura de los soportes de pared

Recomendamos que la superficie del toldo forme un ángulo de aproximadamente 80 grados con la pared cuando esté abierto.

PASO 1

Medición del sitio de montaje

1. Mida la longitud de su toldo a lo largo de la pared donde tiene la intención de instalarlo. Esta línea será el punto más alto de su toldo y debe alinearse con la parte superior del soporte de pared. Use un nivel para trazar una línea de tiza a lo largo de la distancia.
2. Importante: Verifique dos veces que la línea esté nivelada a lo largo de toda la distancia.
3. Asegúrese de que la línea esté centrada sobre la puerta del patio, la ventana u otra característica, si aplica.
4. Ahora que tiene una línea recta y centrada, mida el punto medio y márkuelo. Este es el lugar donde se instalará el soporte de pared central.
5. Tome un soporte de pared y coloque la parte superior del mismo, completamente nivelada, debajo de la línea, como se muestra en la figura a continuación. Marque la posición de todos los soportes de pared y sus agujeros para los tornillos con tiza o un lápiz. Tenga en cuenta que la distancia entre cada soporte de pared debe ser la misma.

Toldo < 10.8' (3.5 m)	Requiere solo 2 soportes de pared en total: uno para cada extremo del tubo de soporte.
Toldo = 10.8 - 14' (3.5 - 4 m)	Requiere 3 soportes de pared en total: uno para cada extremo y uno en el medio.

La distancia entre la alfeizar y el soporte de pared es de 23.9" (10 cm)

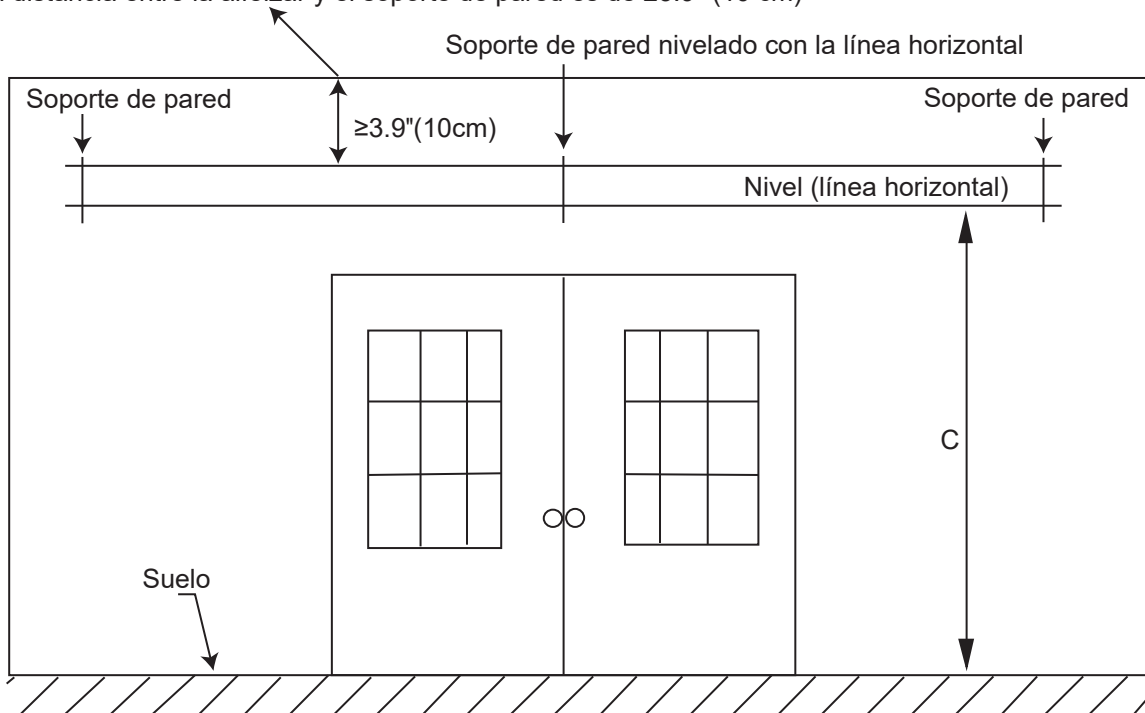

PASO 2

Perforación de los agujeros para los tornillos

1. Ahora que tiene una línea recta y nivelada a lo largo de la pared con las ubicaciones de los soportes de pared y sus agujeros para los tornillos marcados, puede perforar los agujeros para montar los soportes.

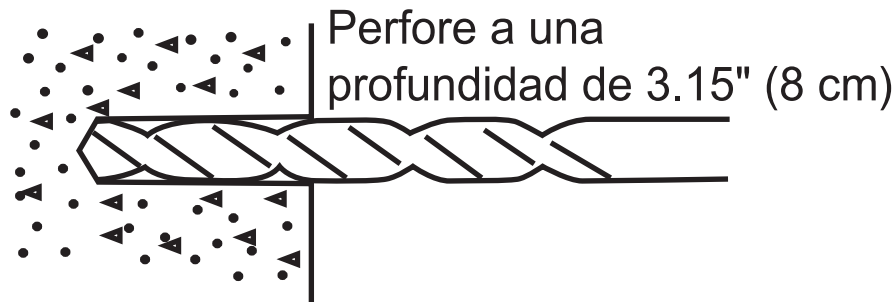

2. Usando una broca de 0.55" (14 mm), perfore el primer agujero para el tornillo a aproximadamente 3.15" (8 cm) de profundidad, como se muestra en la figura. Este debe ser perforado a través de ladrillo sólido o concreto para ofrecer el soporte necesario para el toldo.

3. Perfore los agujeros restantes de la misma manera que en el paso 2.

⚠ ADVERTENCIA

Todos los agujeros para los tornillos deben estar alineados vertical y horizontalmente para asegurar que el toldo cuelgue recto. Verifique la alineación antes de perforar si no está seguro.

⚠ ADVERTENCIA

El diámetro y la profundidad de los agujeros de montaje deben ser del mismo tamaño que los pernos de expansión.

PASO 3

Preparación para el montaje

1. Ahora que todos sus agujeros están perforados, inserte los pernos de expansión.
2. Puede ser necesario golpear los pernos con un martillo de madera (u otro material no metálico).



Si es necesario utilizar un martillo para la instalación, recomendamos colocar la tuerca en el tornillo (de manera suelta) antes de golpear, para evitar dañar las roscas del perno.

3. Asegúrese de que los pernos estén firmemente en su lugar, pero que sobresalgan de la pared aproximadamente 1 pulgada (2.5 cm) o menos, lo suficiente como para poder instalar el soporte de pared sobre ellos.

Apriete firmemente los pernos con una llave hexagonal de 0.75" (19 mm). Es mejor usar la llave hexagonal de extremo cerrado, en lugar de la de extremo abierto, para evitar dañar la tuerca si resbala.

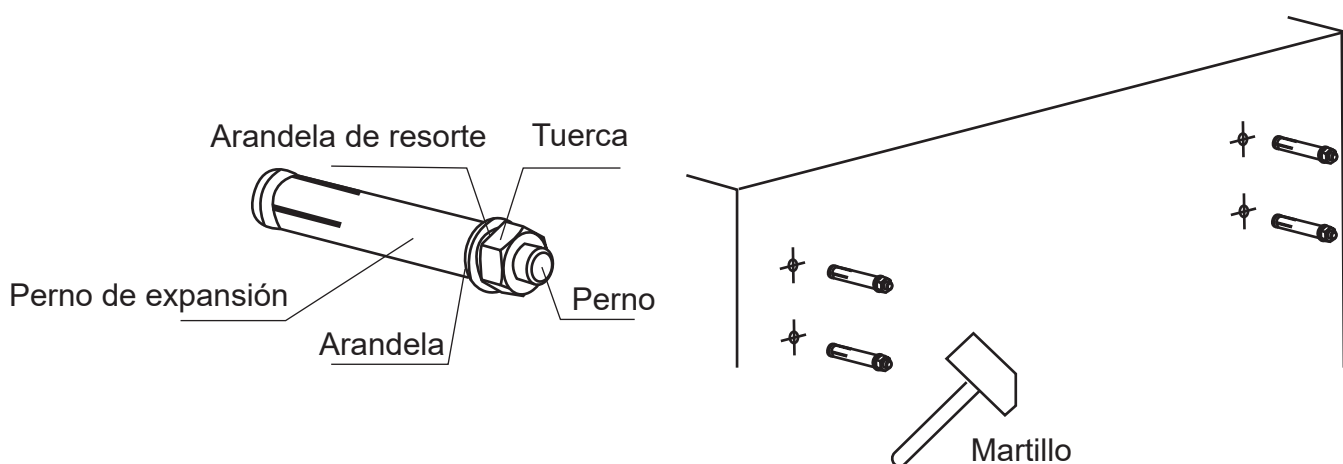

PASO 4

Montaje de los soportes de pared

1. Ahora que los pernos están firmemente instalados en la pared, retire las tuercas que están colocadas de manera suelta sobre los pernos.
2. Coloque un soporte de pared sobre uno de los juegos de pernos. Esto debería encajar fácilmente si los agujeros de los pernos están correctamente alineados.
3. Una vez que el soporte de pared esté apoyado sobre los pernos, coloque una arandela sobre el perno. Luego, asegúrelo con una tuerca, como se muestra en la figura.

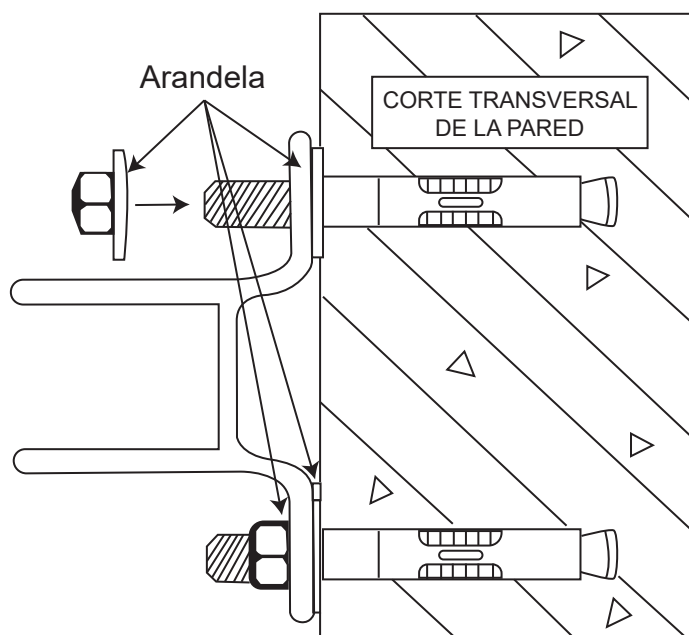

4. Los soportes **DEBEN** quedar firmemente colocados en la pared. Si hay algún movimiento, debe apretarlos más.
5. Repita este paso para cada uno de los soportes de pared. Una vez hecho esto, todos los soportes de pared estarán instalados de forma segura en su lugar.

PASO 5

Montaje del toldo

1. Ahora que los soportes de pared están seguros y en su lugar, es hora de instalar el toldo sobre los soportes.
2. Coloque el tubo de soporte sobre los soportes de pared y apriételos con los tornillos hexagonales.
3. Finalmente, fije todos los pernos de expansión.
4. Usando la manivela o un motor (si aplica), abra completamente su toldo. La barra frontal debe estar nivelada.
5. ¡Felicidades! Su toldo está instalado. Si está satisfecho con la altura de la barra frontal (inclinación del toldo), siéntese y disfrute. Si no es así, por favor continúe leyendo.

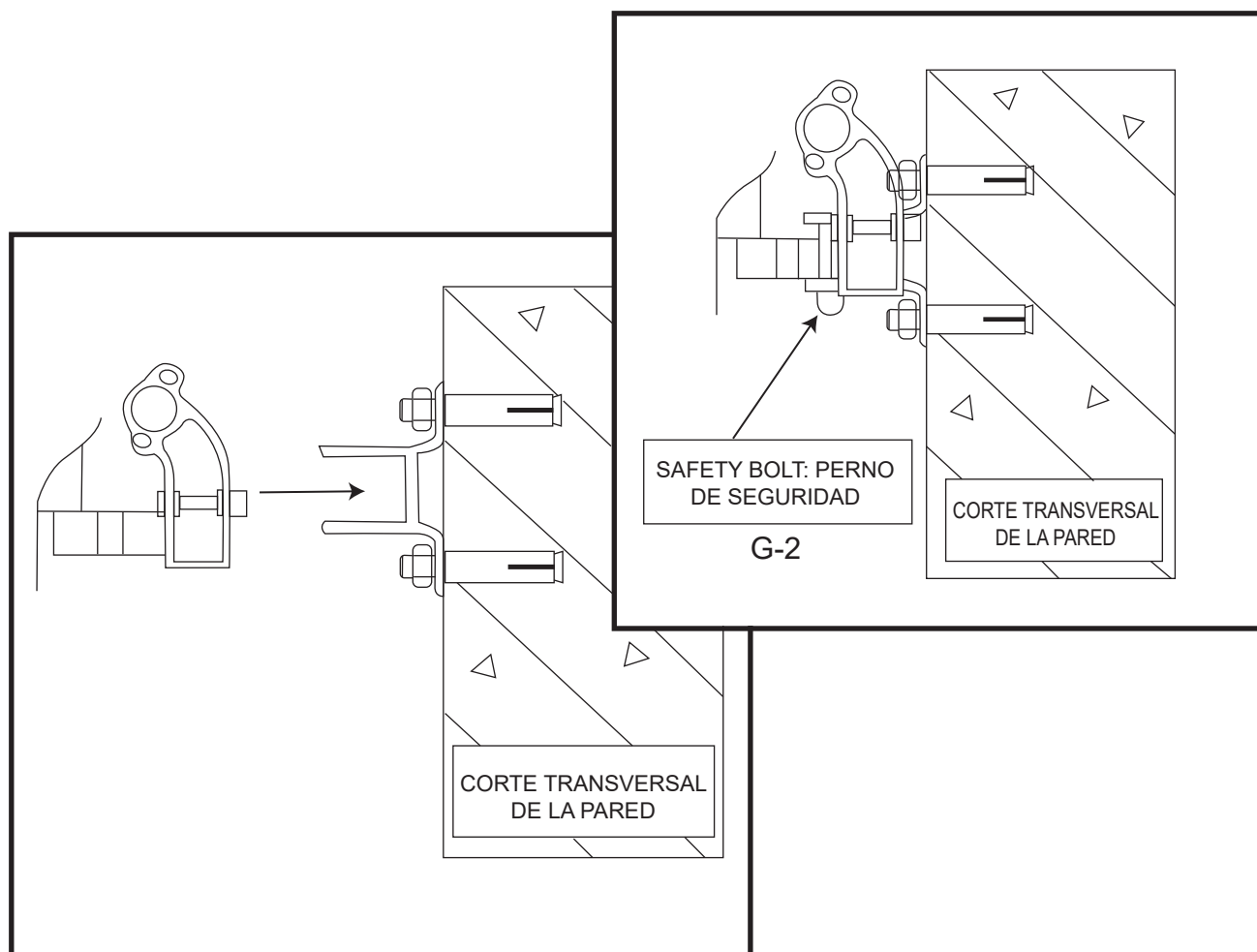

INSTALACIÓN OPCIONAL

Ajuste del toldo

Cada toldo viene con un ángulo preestablecido que se considera ideal. Sin embargo, si necesita realizar un ajuste, se puede hacer en solo unos pocos pasos fáciles.

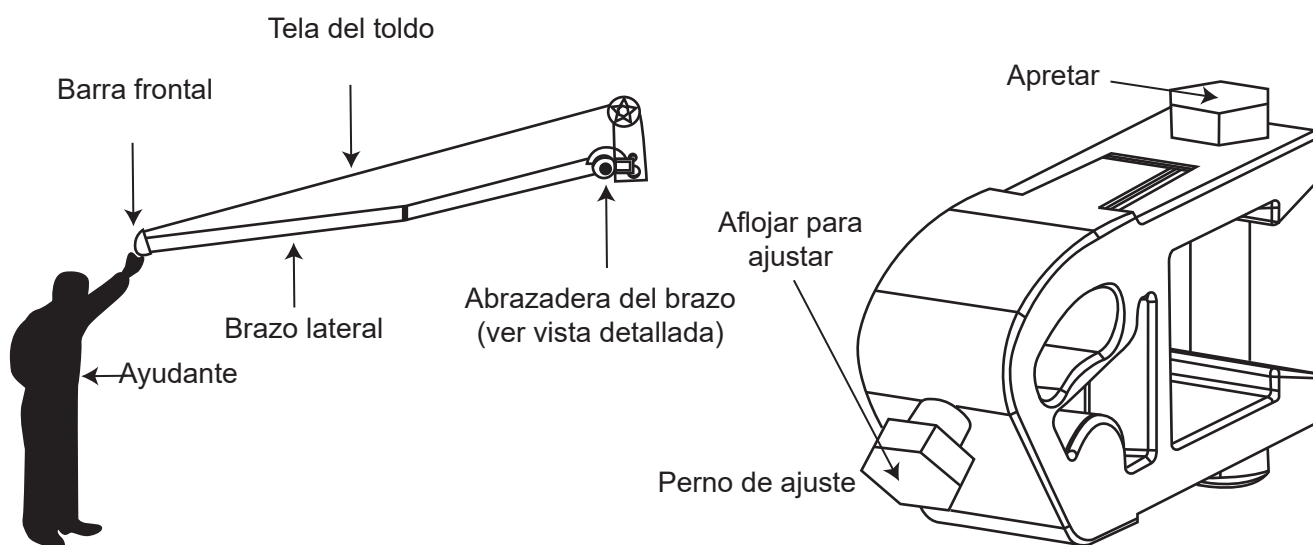

⚠ ADVERTENCIA

Elevar la barra frontal reducirá el ángulo de la tela, lo que aumentará el riesgo de que el agua de lluvia se acumule sobre ella. Para evitar que el toldo se colapse debido al peso del agua de lluvia, debe retraer el toldo cuando no lo esté vigilando. No hacerlo podría resultar en un toldo roto o lesiones personales.

Nota: Asegúrese de que la barra frontal esté ajustada para que quede completamente nivelada. Cualquier desalineación resultará en una retracción inadecuada.

ERRORES COMUNES

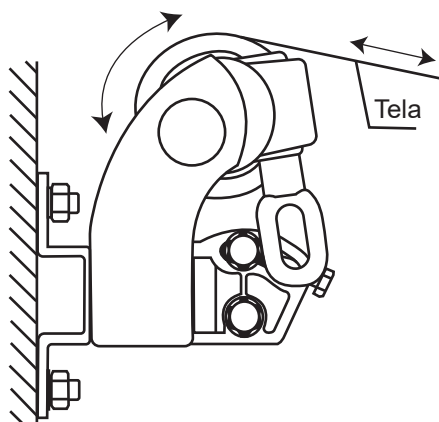

Acción correcta

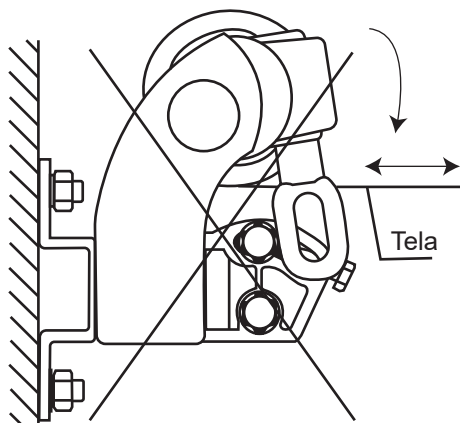

Acción incorrecta

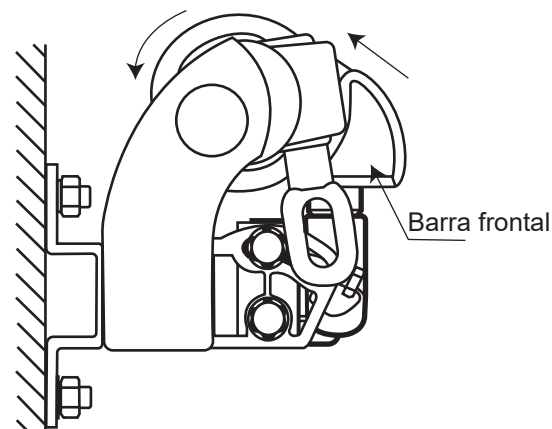

ADVERTENCIA

Cuando la barra frontal toque el rodillo como se muestra en la figura, no intente acercarlos más, ya que podría dañar el producto.

Persona de contacto
Ibérica de Distribuciones online del Hogar,
SLU,
Méndez Álvaro 20,
Madrid 28045,
Teléfono: +34 912907933
www.tectake.es
correo electrónico: mail@idoh.es

Tenda da sole - Istruzioni di montaggio

3x2.5M 2.5x2M

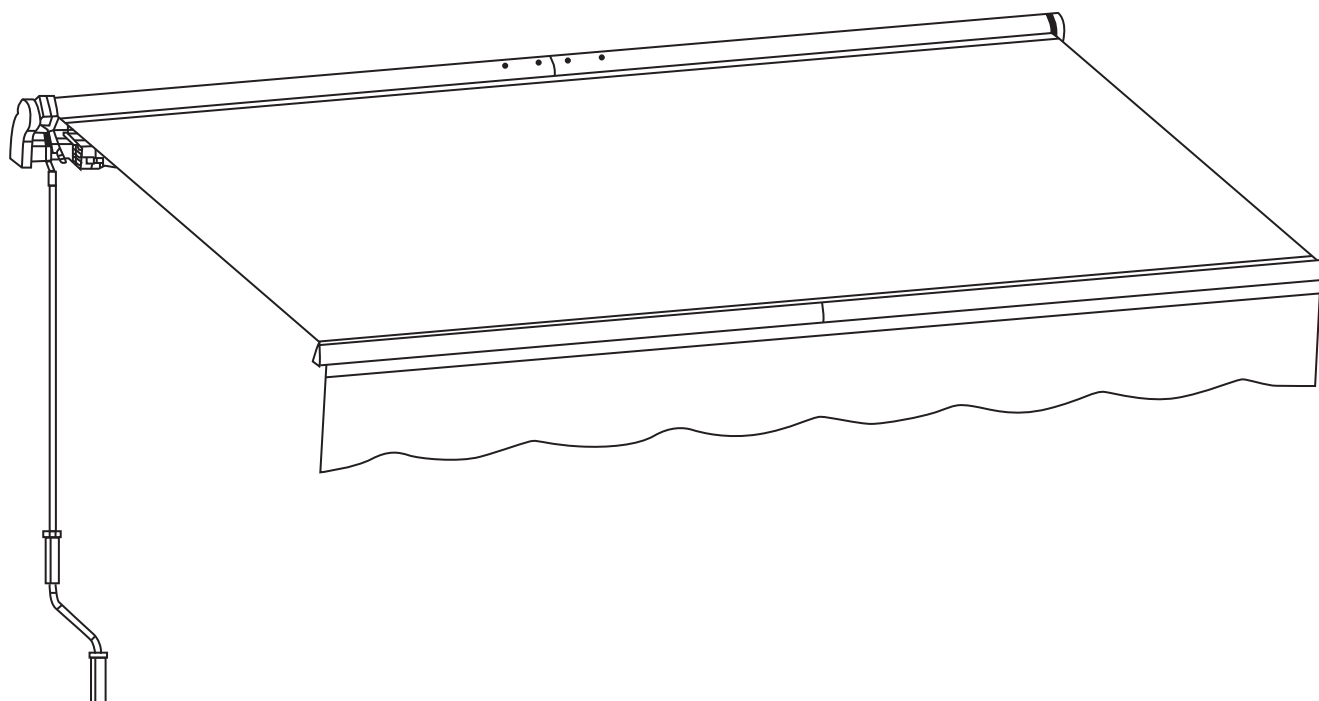

Grazie per aver acquistato la nostra tenda da sole avvolgibile. Ti auguriamo di utilizzarla con soddisfazione negli anni a venire.









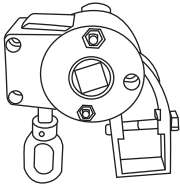
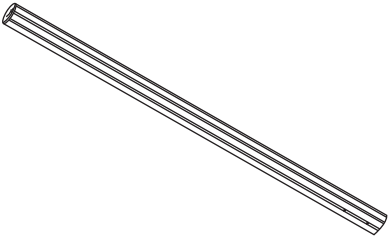
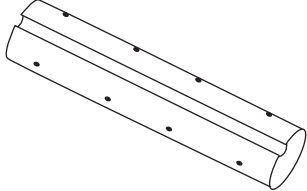
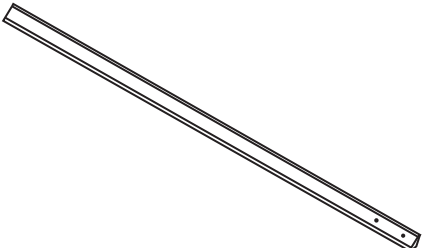
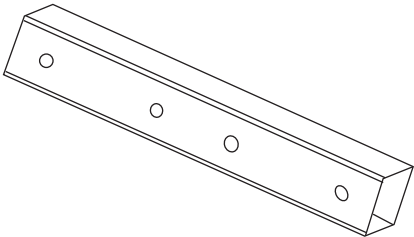
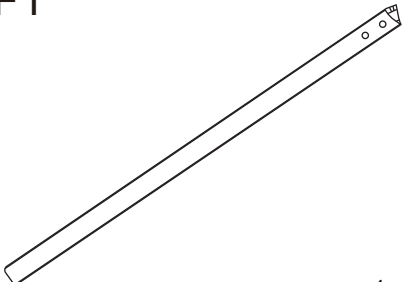
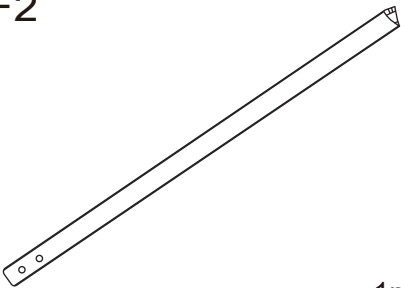
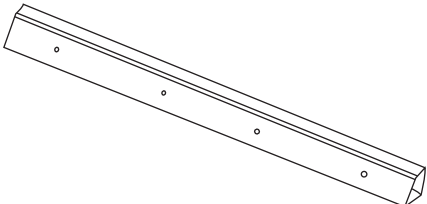
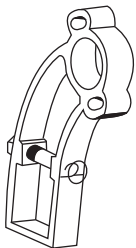
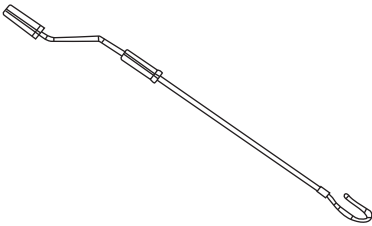
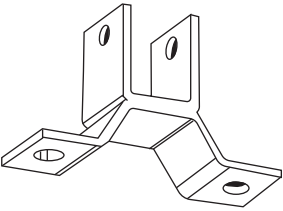
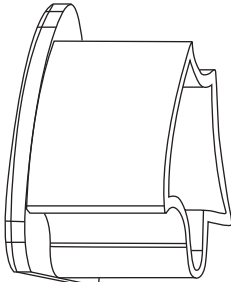
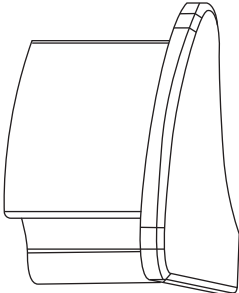
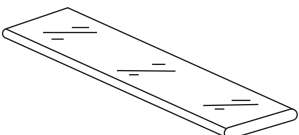
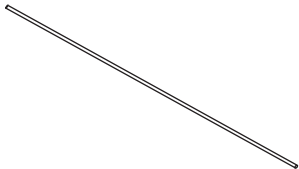

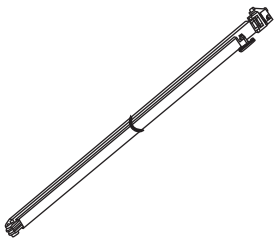
Per garantire la tua incolumità durante il montaggio e per utilizzare al meglio il prodotto ti consigliamo di leggere attentamente queste istruzioni prima di iniziare.

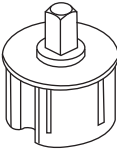
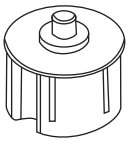
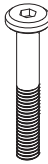
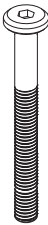
L'installazione di questa tenda deve essere eseguita da almeno due persone. Se il montaggio risulta troppo difficile, ti suggeriamo di avvalerti dell'assistenza professionale di un installatore o di un carpentiere.

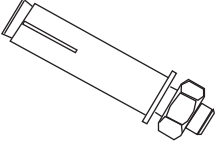
Puoi contattare il nostro servizio clienti online per assistenza in caso di problemi durante il montaggio, pezzi mancanti o difettosi o altro. Faremo il possibile per risolverli.

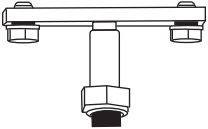
Elenco dei pezzi: Installazione facoltativa

<p>A</p>  <p>1pc</p>	<p>B</p>  <p>2pcs</p>	<p>C</p>  <p>1pc</p>
<p>D</p>  <p>2pcs</p>	<p>E</p>  <p>1pc</p>	<p>F1</p>  <p>1pc</p>
<p>F2</p>  <p>1pc</p>	<p>G</p>  <p>1pc</p>	<p>H</p>  <p>1pc</p>
<p>I</p>  <p>1pc</p>	<p>J</p>  <p>2pcs</p>	<p>K1</p>  <p>1pc</p>
<p>K2</p>  <p>1pc</p>	<p>L</p>  <p>1pc</p>	<p>M</p>  <p>3pcs</p>

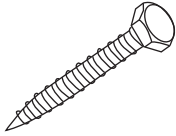
<p>N1</p>  <p>1pc</p>	<p>N2</p>  <p>1pc</p>	<p>O1</p>  <p>1pc</p>	
<p>O2</p>  <p>1pc</p>	<p>P1</p>  <p>M6x40</p> <p>4pcs</p>	<p>P2</p>  <p>M8x55</p> <p>2pcs</p>	<p>Q</p>  <p>M8</p> <p>2pcs</p>
<p>R</p>  <p>M6</p> <p>4pcs</p>	<p>S</p>  <p>4pcs</p>	<p>T</p>  <p>M5x16</p> <p>16pcs</p>	<p>U</p>  <p>2pcs</p>
<p>V</p>  <p>M8</p> <p>2pcs</p>	<p>W</p>  <p>2pcs</p>	<p>X</p>  <p>M3x10</p> <p>2pcs</p>	<p>Z</p>  <p>M10x72</p> <p>4pcs</p>

Prima del montaggio preparare i seguenti attrezzi (non inclusi)

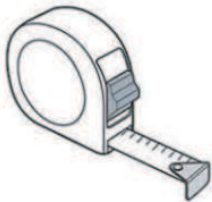
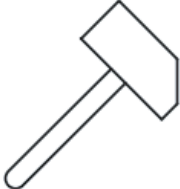
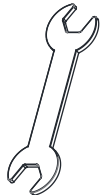
<p>Metro a nastro</p>	<p>Martello morbido</p>	<p>Chiave (misura M17 e M14)</p>
		

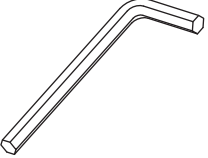
Cacciavite a croce	Trapano con punta per forature da 14 mm	Livella	Brugola da 8 mm
			

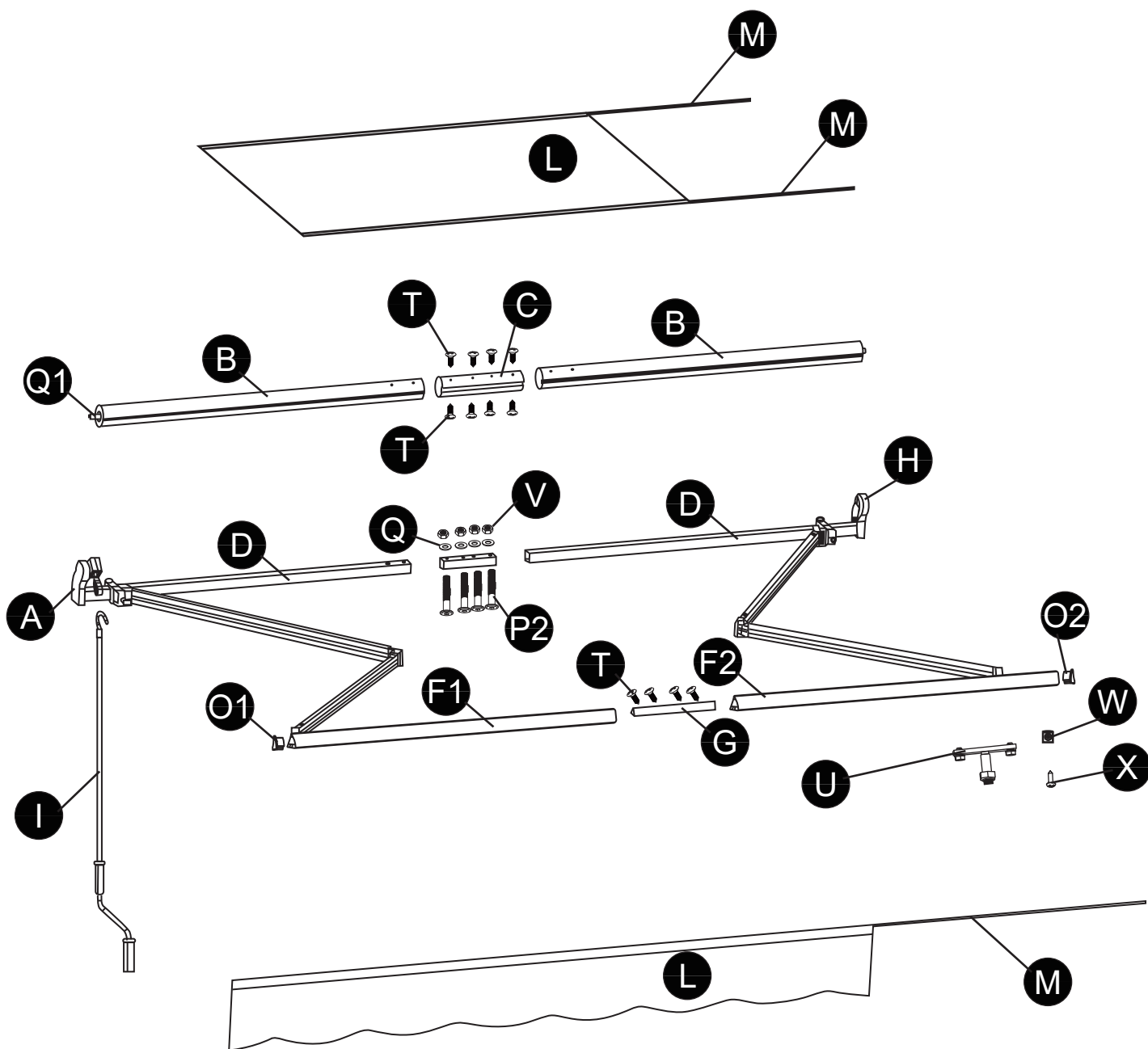

Preparazione dello spazio di lavoro

1. Prima di iniziare si consiglia di preparare tutti gli attrezzi necessari per agevolare il montaggio.
Fare riferimento all'elenco di attrezzi sopra riportato.

PERICOLO

NON rimuovere la cinghia di sicurezza che tiene insieme i bracci della tenda.
Una rimozione anticipata della cinghia di sicurezza comporta un rischio di lesioni.

2. Aprire la scatola e disimballare tutti i pezzi con cautela per evitare di danneggiare il prodotto.
3. Disporre tutti i pezzi della tenda parasole per verificare che non manchi niente.
Consultare lo schema per le informazioni dettagliate sui pezzi forniti.
4. Aprire la scatola piccola all'interno della confezione, che contiene le minuterie, e disporle sull'area di lavoro.

Assemblaggio:

Passaggio 1: assemblaggio del rullo

Mantenendo gli elementi allineati, assemblare il rullo con i connettori e fissarlo con i bulloni corrispondenti come illustrato di seguito.

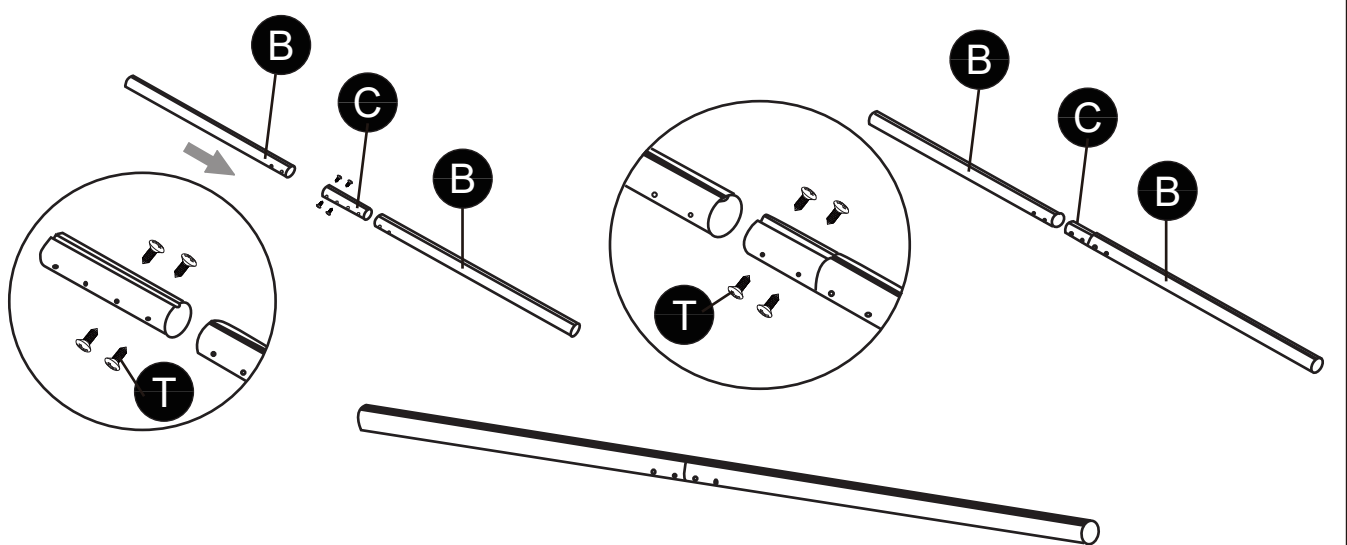

Passaggio 2: assemblaggio della barra di torsione e del braccio

mantenendo le quattro facce allineate, assemblare la barra di torsione con i connettori e fissarla con i bulloni corrispondenti come illustrato di seguito.

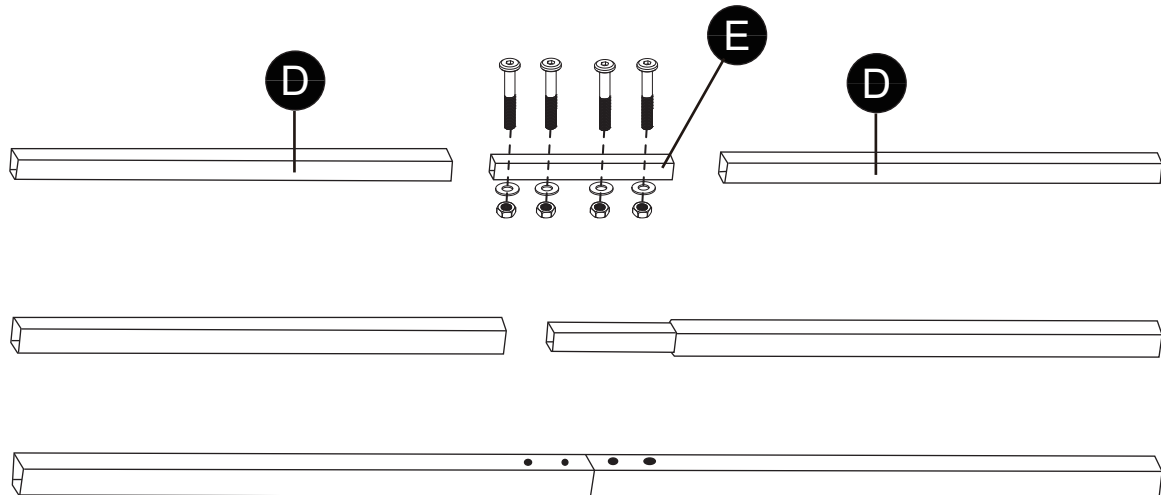

Dopodiché montare il braccio sulla barra di torsione come illustrato. I bracci vanno rivolti nella stessa direzione. La cinghia del braccio non deve essere sbloccata finché l'assemblaggio non è completo.

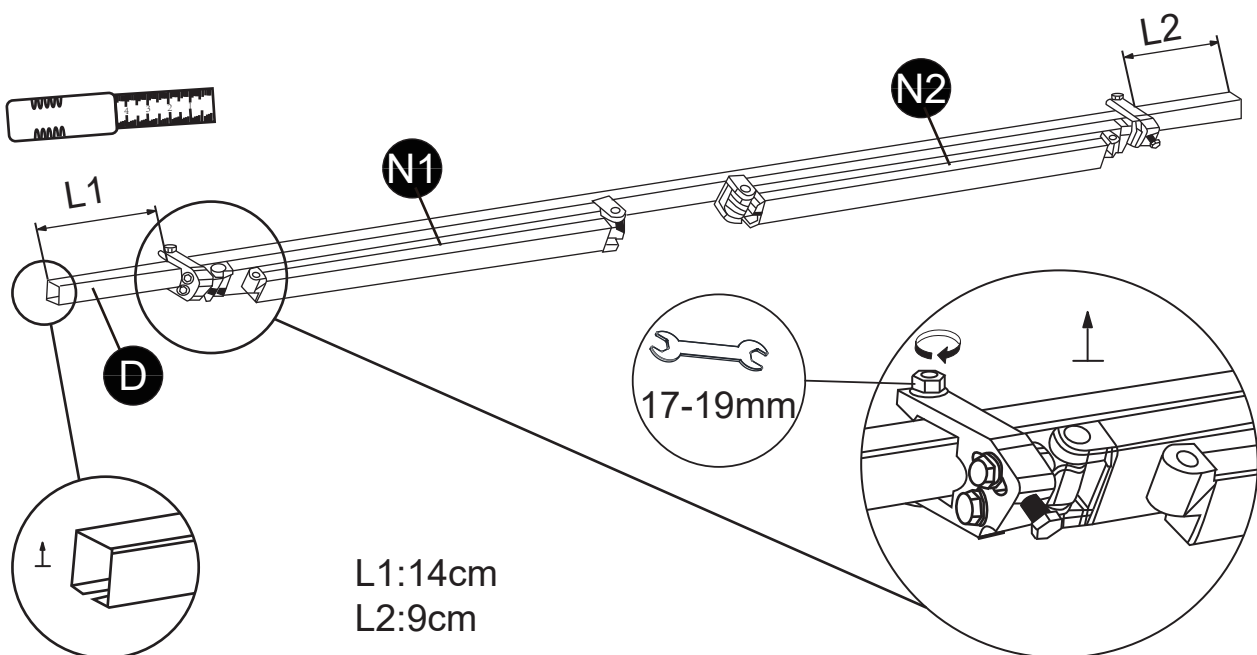

Passaggio 3: assemblaggio della barra frontale

Collegare la barra frontale ai connettori e fissarla con i bulloni corrispondenti come illustrato (mantenere la barra allineata).

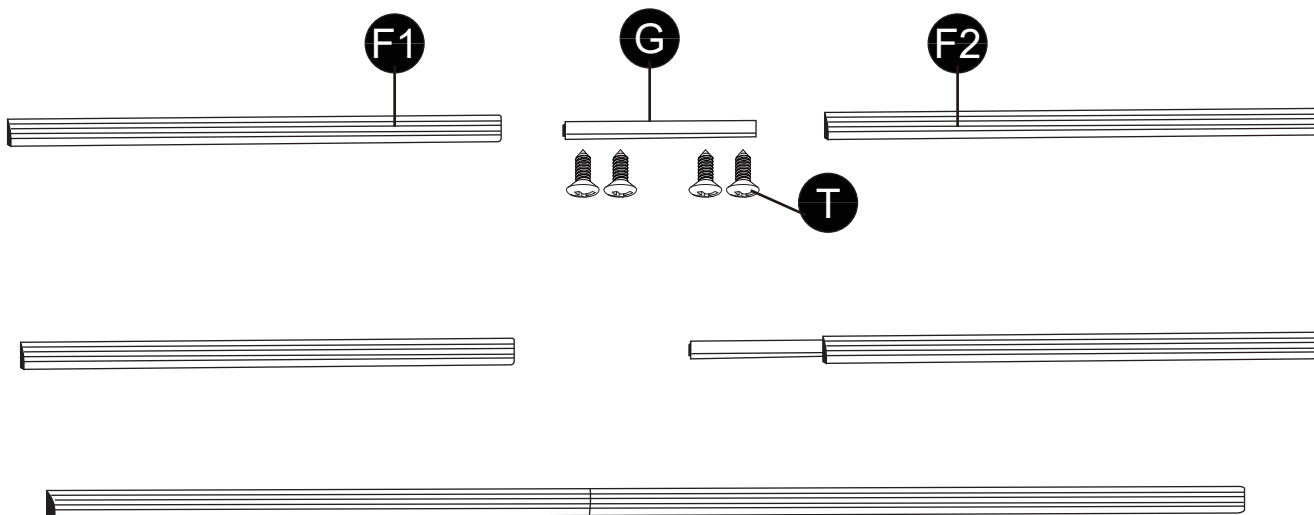

Passaggio 4: assemblaggio del supporto della barra frontale

Far scorrere il perno della barra frontale nella barra, senza serrare, come illustrato di seguito.



Passaggio 5: assemblaggio della barra frontale sui bracci

Inserire il perno della barra frontale attraverso il foro del braccio piccolo e posizionare la barra frontale. Al termine, serrare con la chiave come illustrato.

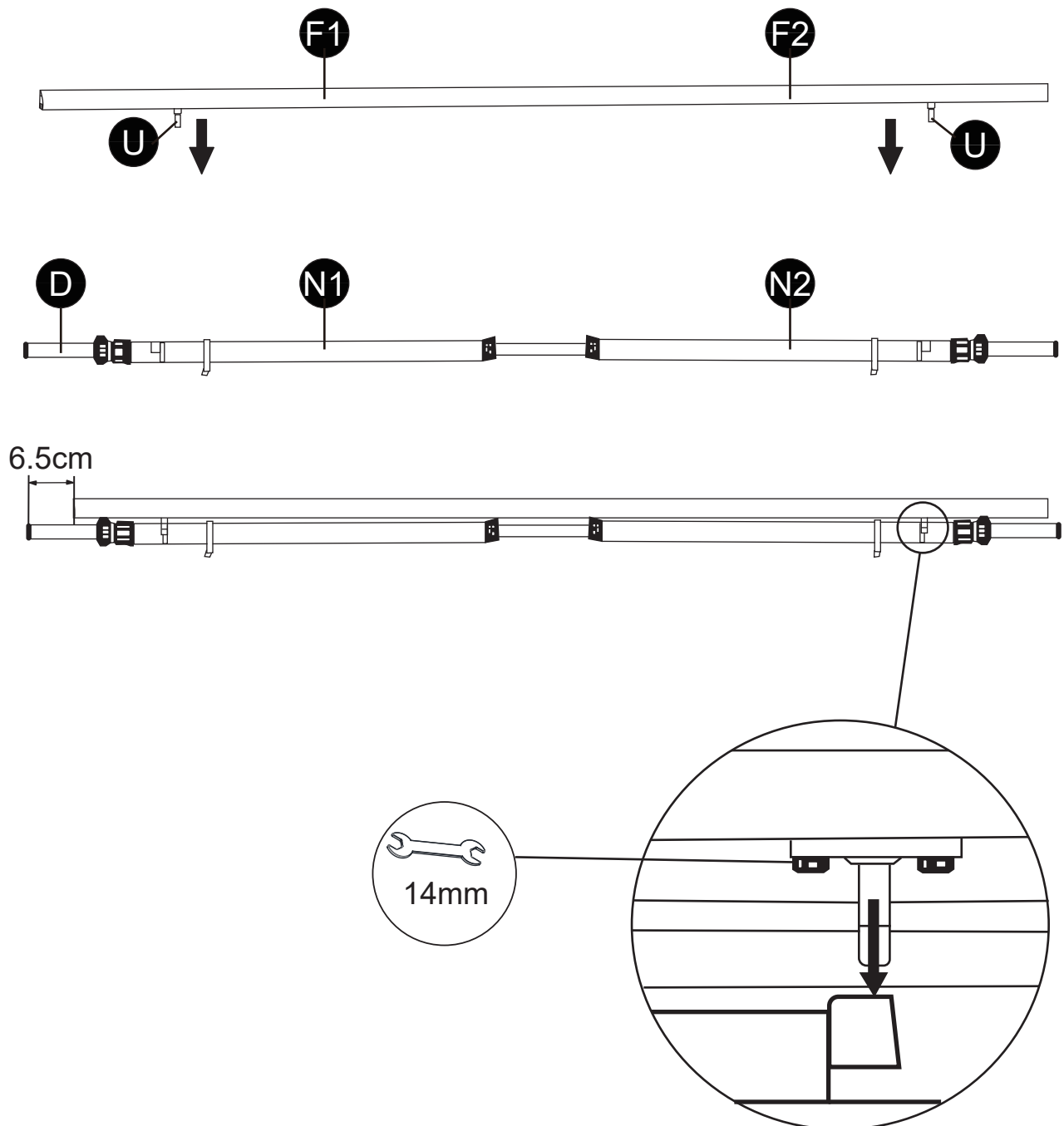

Passaggio 6: inserimento del dado autobloccante

Inserire il dado autobloccante nella filettatura sul perno della barra frontale con una chiave, lasciando 1~2 giri sulla filettatura, come illustrato di seguito.

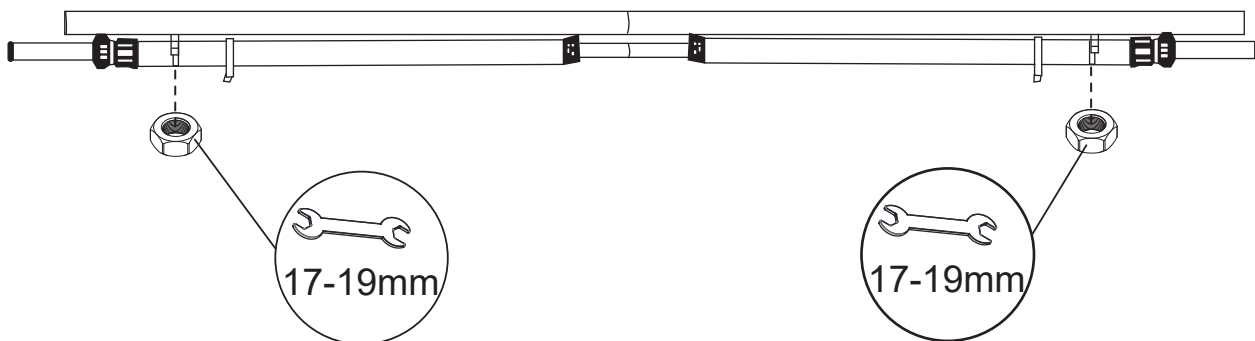

ATTENZIONE: PRIMA DI BLOCCARE IL DADO VERIFICARE CHE I BRACCI SIANO ALLINEATI CORRETTAMENTE.

Passaggio 7: Supporto sinistro del rullo con meccanismo di avvolgimento

Inserire il supporto sinistro con il meccanismo di avvolgimento sull'estremità sinistra della barra di torsione con un martello morbido. Dopodiché serrare il bullone esagonale da 5 mm come illustrato di seguito.

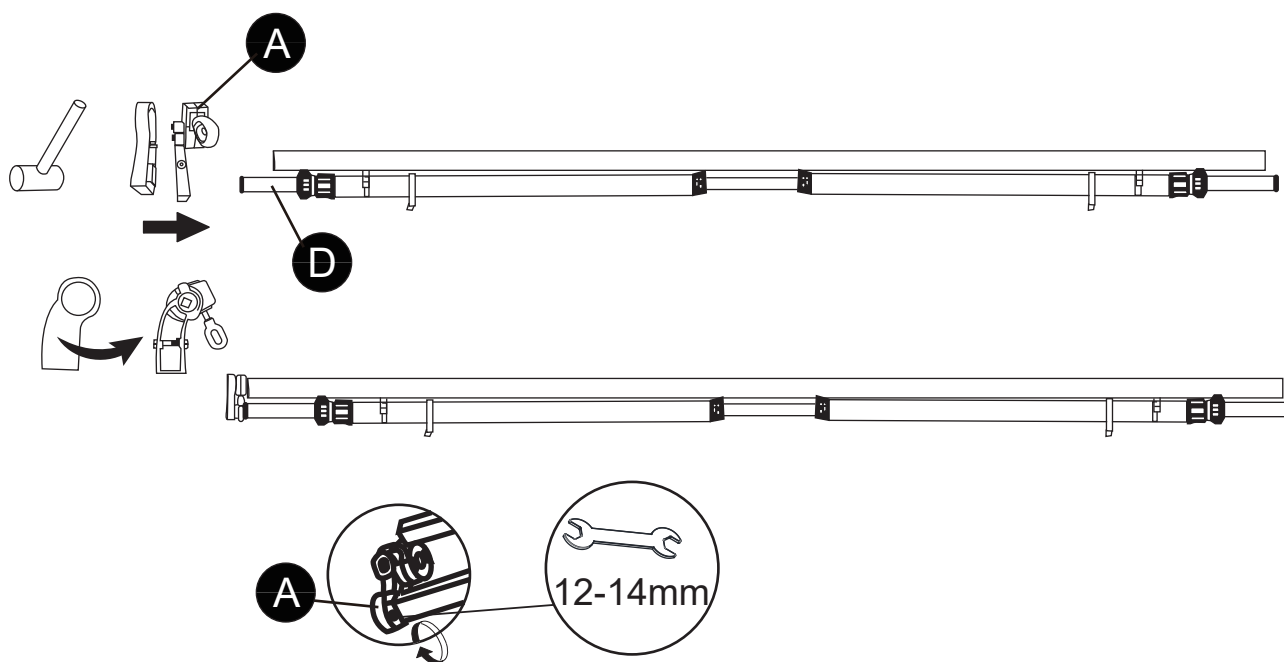

Passaggio 8: assemblaggio del telo e della mantovana

Aprire il sacco e stendere il telo 14A e la mantovana 14B. Inserire il cavo di guida attraverso il tessuto come illustrato di seguito.

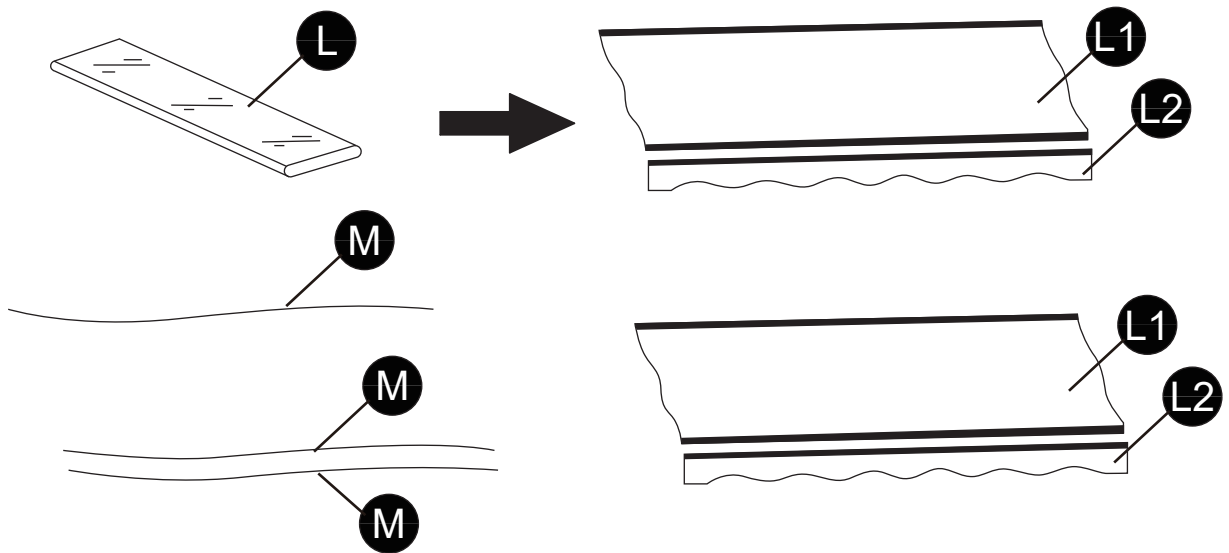

Passaggio 9: avvolgimento del telo sul rullo

Avvolgere il telo sul rullo, prestando attenzione alla direzione del telo come illustrato di seguito.

Il tessuto va rivolto verso l'alto durante l'assemblaggio. Mantenere la stessa distanza a entrambe le estremità.

Distendere il telo con cautela per evitare danni.

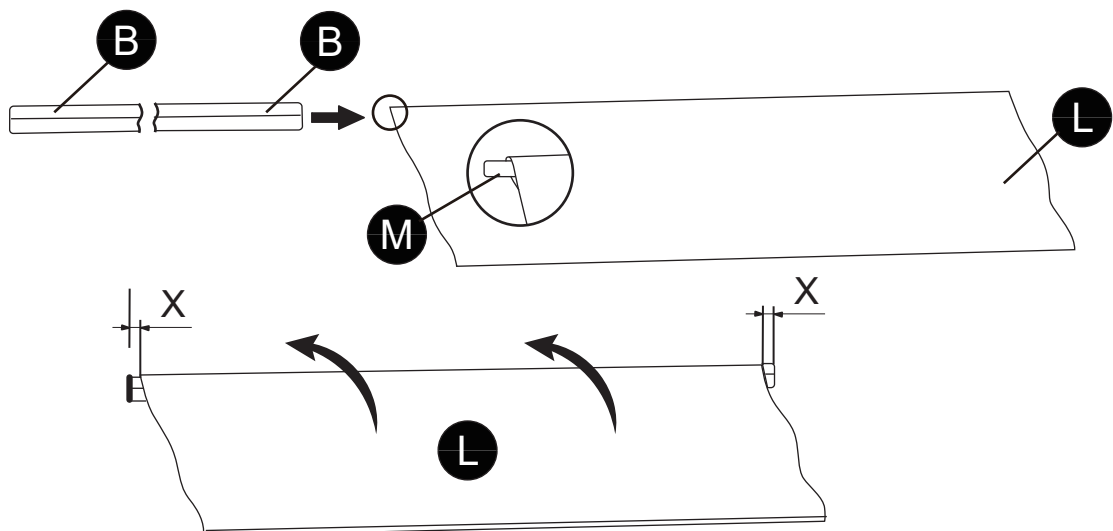

Passaggio 10: installazione del telo

Inserire un'estremità del telo nella scanalatura sulla barra frontale, distribuendolo uniformemente. Dopodiché, inserire l'albero del rullo nel foro quadrato sul meccanismo di avvolgimento come illustrato di seguito.

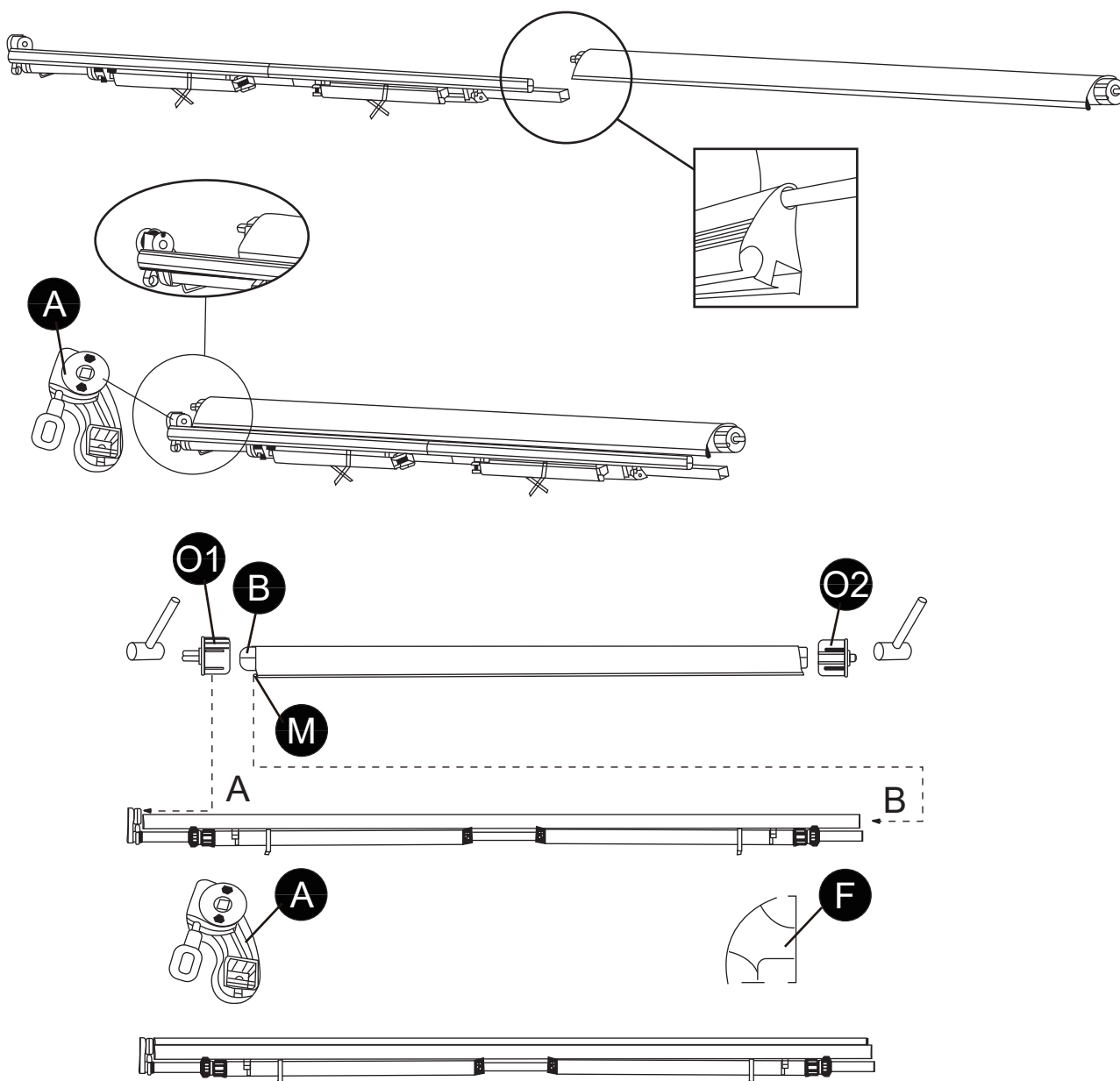

Se una sezione della barra anteriore si deforma leggermente, correggere come richiesto con gli attrezzi.

Passaggio 11: assemblaggio del supporto destro del rullo

Inserire il tappo del rullo sul tubo e contemporaneamente inserire la barra di torsione nei supporti sul lato destro con un martello morbido. Serrare il bullone esagonale da 5 mm sul lato destro con la chiave come illustrato di seguito.

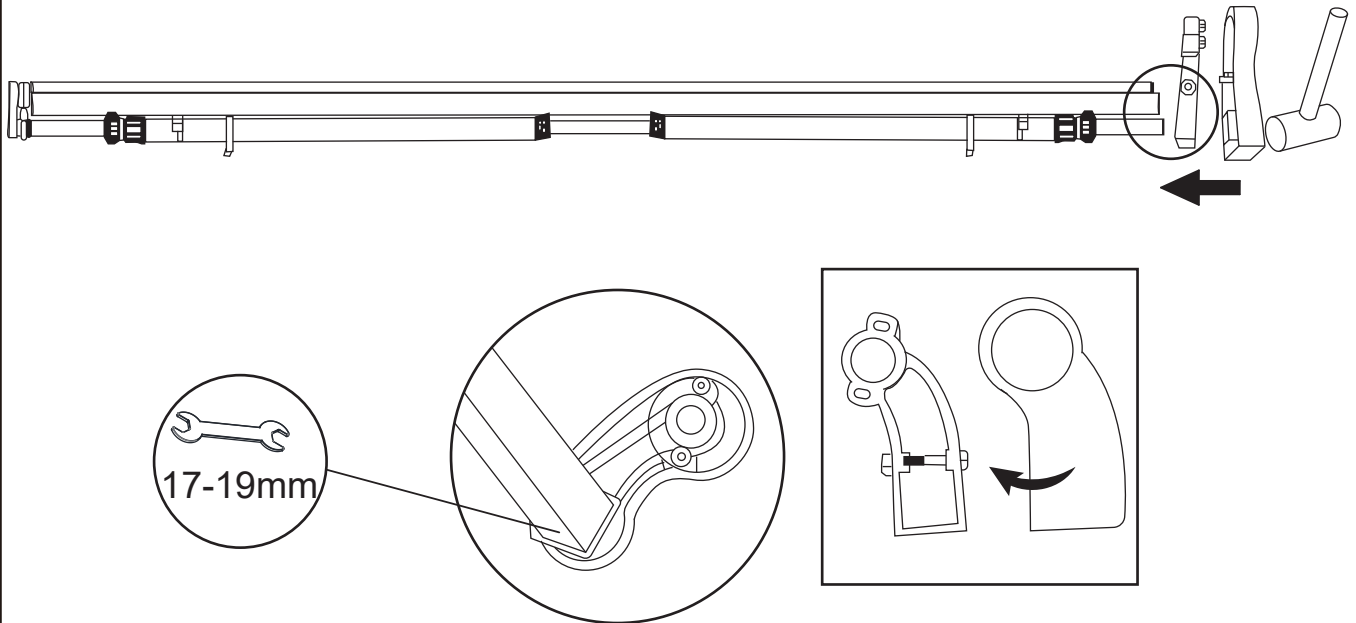

Passaggio 12: assemblaggio completo

Far passare la mantovana attraverso la scanalatura sulla barra frontale, prestando attenzione alla direzione e verificando che entrambi i lati siano pareggiati. Dopodiché inserire la copertura della barra frontale come illustrato di seguito.

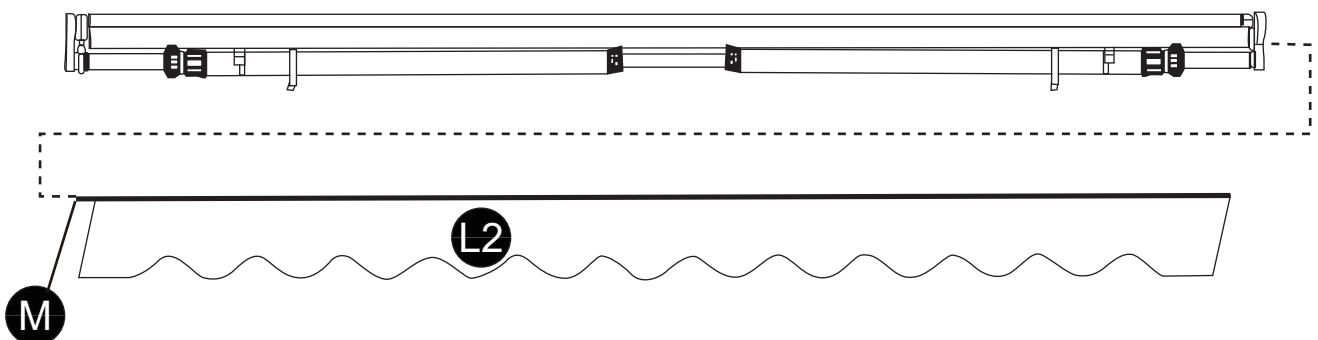

Se una sezione della barra anteriore si deforma leggermente, correggere come richiesto con gli attrezzi.

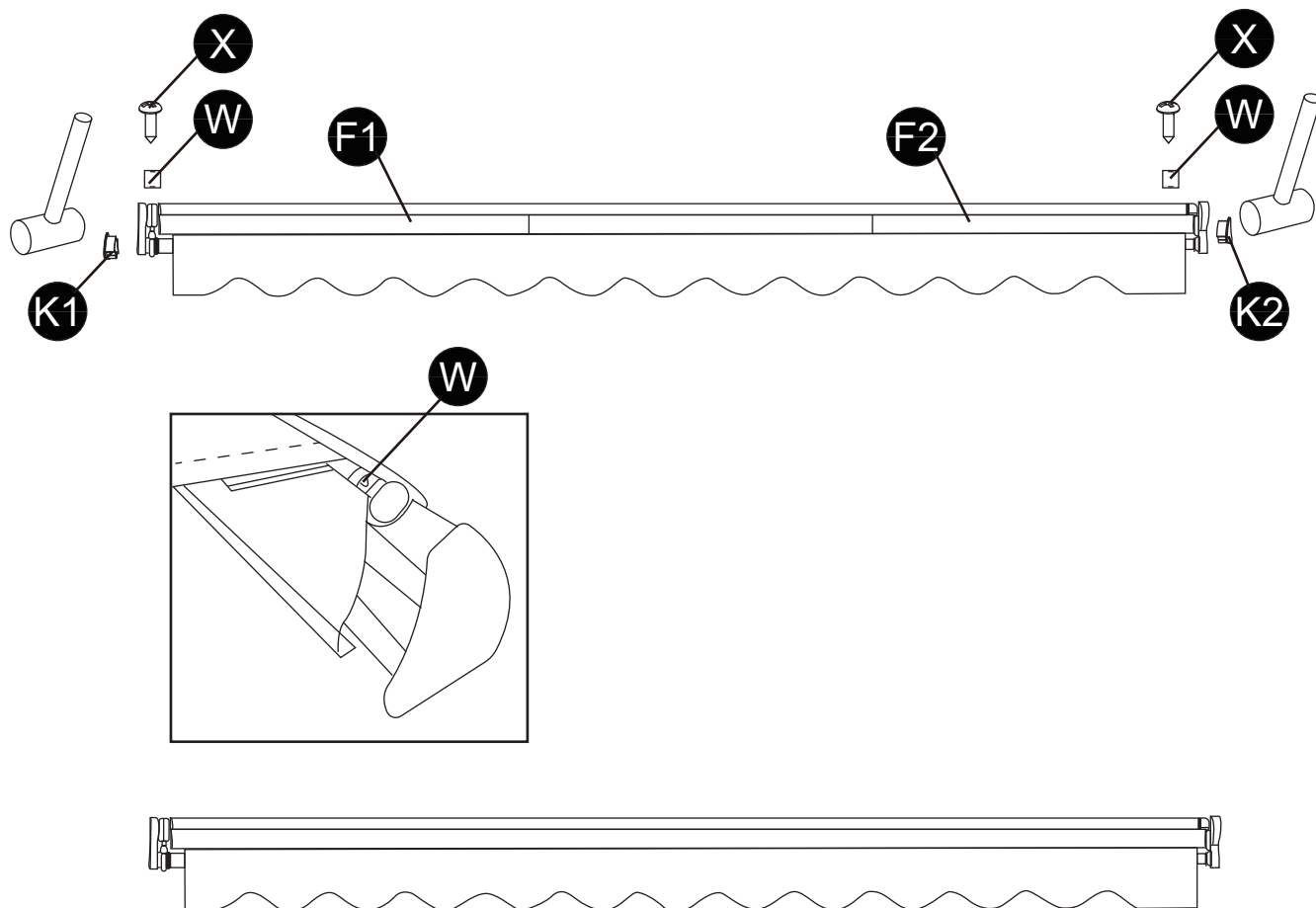

Se il tessuto si avvolge in modo non uniforme o i due bracci non si aprono nello stesso momento, verificare la stabilità dei due bracci. Soluzione: se necessario, regolare la posizione del collegamento del braccio verso l'esterno.

Dati tecnici

Nome del prodotto	Tenda da sole avvolgibile (vedere i dettagli sulla confezione)
Trattamento del materiale e della superficie	Materiali: acciaio tubolare, lega di alluminio, plastica, poliester Trattamento delle superfici Tubi: verniciatura spray e antiruggine Tessuto: trattamento PU, UV e idrorepellente
Pareti idonee per il montaggio	Pareti in cemento armato, mattoni e legno
Altezza di montaggio raccomandata	2.5m-4m 8'-13'
Condizioni di utilizzo	Il prodotto protegge dai raggi solari. Utilizzabile con vento al di sotto del livello 5. Non adatto per l'uso in caso di pioggia.





Montaggio a parete

Note sul montaggio a parete

Questa tenda da sole può essere fissata su pareti in cemento armato, mattoni e legno. Nella confezione sono però inclusi viti per il montaggio su pareti in mattoni e cemento armato.

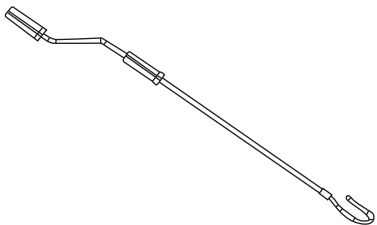
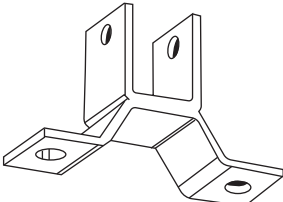
Per il montaggio della tenda su pareti in legno, utilizzare viti apposite della giusta lunghezza e di diametro sufficiente per il fissaggio su travi in legno. La misura dei bulloni dipende dalle dimensioni del legno. I bulloni possono essere acquistati in un negozio di ferramenta. Per un'installazione sicura si raccomanda di affidarsi a un professionista.

Non tentare di fissare le staffe su muri a secco in pietra o su qualsiasi altra superficie non perfettamente legata.

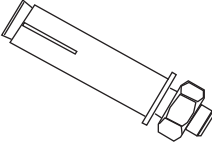
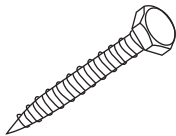
I  1pc	J  2pcs	P2  M8x55 2pcs	
Q  M8 2pcs	V  M8 2pcs	S  4pcs	Z  M10x72 4pcs

! ATTENZIONE

Il posizionamento delle staffe è la parte più importante del processo di montaggio. È fondamentale fissare le staffe su montanti, travi, architravi o altri elementi strutturali portanti.

! PERICOLO

Un fissaggio inadeguato delle staffe a parete potrebbe causare il crollo della tenda parasole con conseguente rischio di lesioni e morte.

Altezza di montaggio

Prima di fissare i supporti a parete è necessario considerare il raggio di movimento della tenda parasole. Se ad esempio si monta la tenda sopra la porta di un patio, lasciare almeno 20,5 cm di spazio al di sopra del telaio della porta per garantire che la tenda non interferisca con l'apertura e la chiusura della porta. L'angolo di discesa ha un intervallo di regolazione minimo; tenere in considerazione questo aspetto ai fini del posizionamento della tenda.

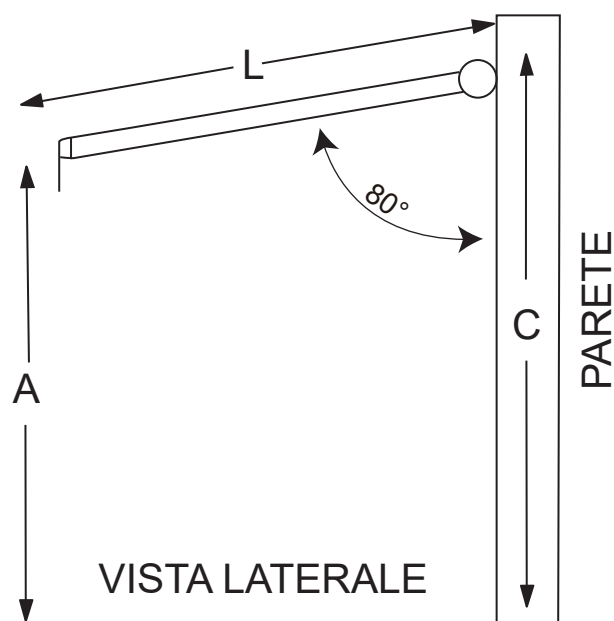

Altezza di montaggio raccomandata:
2,5 m-4 m. L'angolo di discesa ottimale
(a estensione completa) è già impostato
di fabbrica, per cui non è necessario
modificarlo.

CALCOLI:

Utilizzare questa formula per calcolare
l'angolo corretto.

$$C = A + 0,17 * L$$

A = Lunghezza desiderata della barra frontale

L = Lunghezza del braccio esteso

C = Altezza delle staffe a parete

Tra la superficie della tenda parasole aperta e la parete dovrebbe formarsi un angolo di circa 80 gradi.

PASSAGGIO 1

Misurazione del luogo di montaggio

1. Misurare la lunghezza della tenda parasole sul muro su cui si desidera installarla. Questa linea rappresenta il punto più alto della tenda, a cui le staffe a parete andranno allineate. Utilizzare una livella per segnare una linea sulla misura.
 2. Importante: controllare due volte che la linea sia dritta in tutte le direzioni.
 3. Assicurarsi che la linea sia centrata rispetto alla porta, alla finestra o a qualsiasi altro riferimento.
 4. Dopo aver ottenuto una linea dritta e centrata, misurare il punto centrale e segnarlo. Quest'ultimo servirà per posizionare la staffa centrale.
 5. Prendere una staffa e posizionarla a filo sotto la linea, come illustrato di seguito. Con un pennarello o una matita, segnare la posizione di tutte le staffe e dei relativi fori.
- Nota: la distanza tra le staffe deve essere uguale.

Tenda < 3,5 m	Per il montaggio sono sufficienti 2 staffe a parete, una per ciascuna estremità della barra di torsione.
Tenda da 3,5 m-4 m	Per il montaggio sono necessarie 3 staffe a parete, una per ciascuna estremità e l'altra al centro.

Distanza tra gronda e staffa a parete: 10 cm

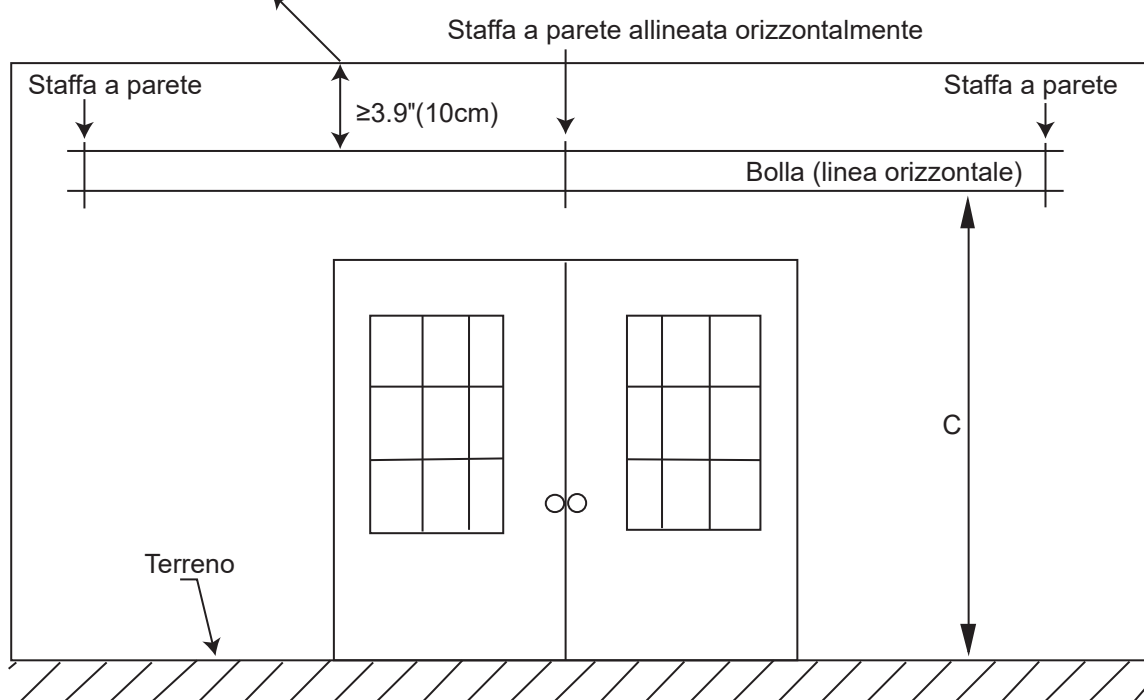

PASSAGGIO 2

Esecuzione dei fori sulla parete

1. Una volta ottenuta una linea retta sul muro con le posizioni di delle staffe e dei relativi fori, è possibile praticare i fori per le staffe.

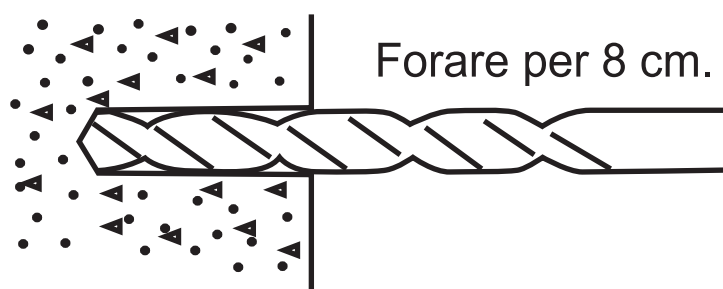

2. Utilizzando una punta da 14 mm, praticare il primo foro a una profondità di 8 cm, come illustrato di seguito. Per offrire il necessario supporto alla tenda parasole, il foro deve essere praticato su mattoni pieni o cemento.

3. Praticare gli altri fori esattamente come da passaggio 2.

! PERICOLO

Tutti i fori devono essere allineati verticalmente e orizzontalmente per garantire che la tenda sia perfettamente dritta.

In caso di dubbio, verificare due volte prima di forare.

! PERICOLO

Il diametro e la profondità dei fori devono essere uguali alle misure dei bulloni a espansione.

PASSAGGIO 3

Preparazione al montaggio

1. Dopo aver praticato tutti i fori, inserire i bulloni a espansione.
2. Potrebbe essere necessario dover inserire i bulloni con un martello morbido.



Se è necessario utilizzare un martello, si raccomanda di inserire il dado sulla vite (senza serrarlo) per evitare di danneggiare le filettature.

3. Assicurarsi che i bulloni siano saldamente in posizione, lasciandoli sporgere di circa 2,5 cm o quanto basta per poter fissare agevolmente la staffa a parete. Serrare i bulloni con una chiave esagonale da 19 mm. Si raccomanda di usare una chiave a bussola invece di una chiave a forchetta per evitare di danneggiare il dado.

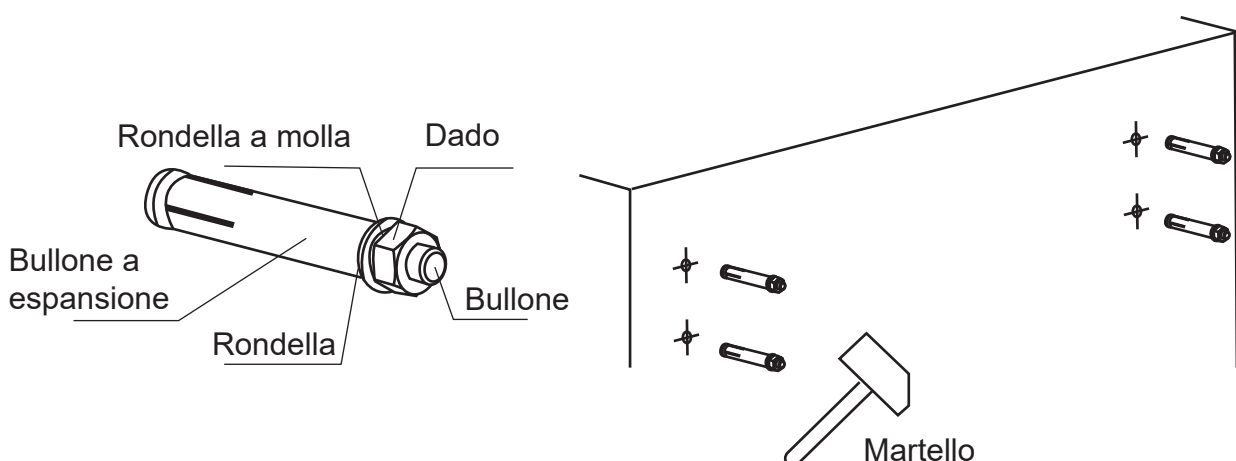

PASSAGGIO 4

Montaggio delle staffe a parete

1. Dopo aver montato i bulloni sulla parete, rimuovere i dadi inseriti a mano sui bulloni.
2. Posizionare una staffa a parete sui bulloni. Se i fori sono stati praticati correttamente l'inserimento dovrebbe essere agevole.
3. Dopo aver inserito la staffa sui bulloni, posizionare una rondella sul bullone. Dopodiché fissare con un dado come illustrato di seguito.

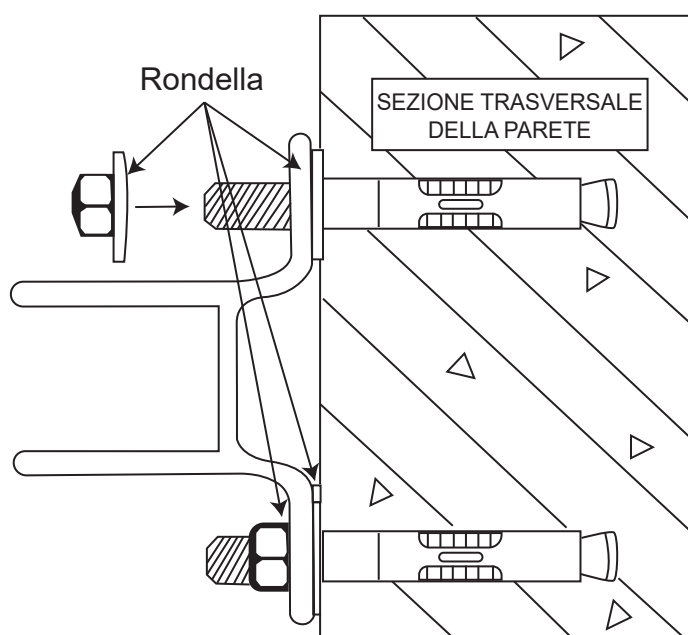

4. Le staffe DEVONO essere saldamente fissate sulla parete. Se si muovono è necessario serrare ulteriormente.
5. Ripetere questo passaggio per ogni staffa a parete. Al termine, tutte le staffe saranno saldamente fissate in posizione.

PASSAGGIO 5

Montaggio della tenda parasole

1. Dopo aver montato tutte le staffe saldamente in posizione è possibile installare la tenda parasole sulle staffe.
2. Posizionare le barre di torsione sulle staffe a parete e fissarle con le viti esagonali
3. Dopodiché serrare tutti i bulloni a espansione.
4. Aprire completamente la tenda con la manovella o il motore (se applicabile).
La barra frontale dovrebbe essere dritta.
5. Congratulazioni! La tenda parasole è stata installata. Se l'altezza della barra frontale (inclinazione) è soddisfacente, l'installazione è completata. In caso contrario continuare a leggere.

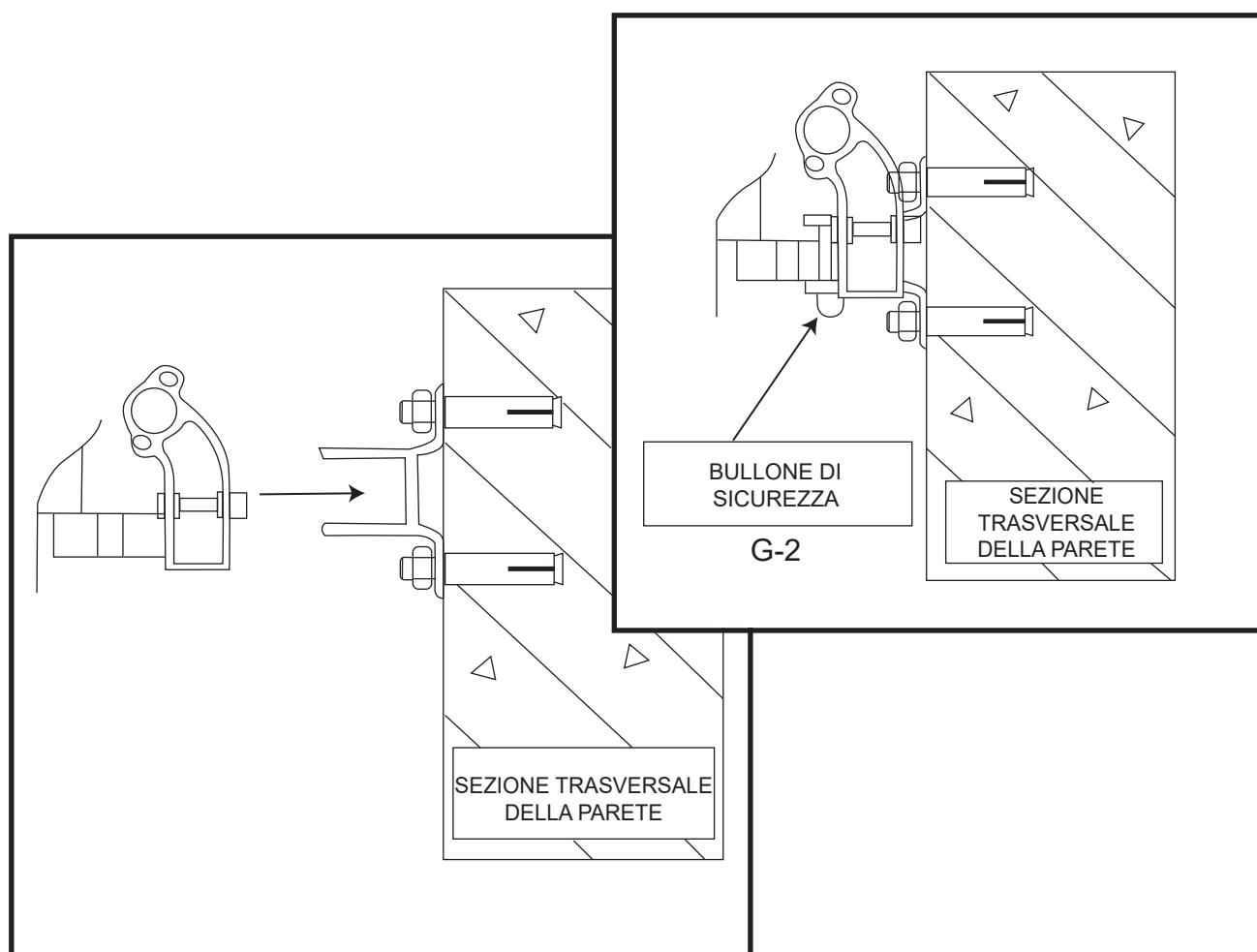

INSTALLAZIONE FACOLTATIVA

Regolazione della tenda

Ogni tenda parasole viene fornita con un'angolazione ottimale preimpostata. Se è necessaria una regolazione, questa può essere eseguita in pochi semplici passaggi.

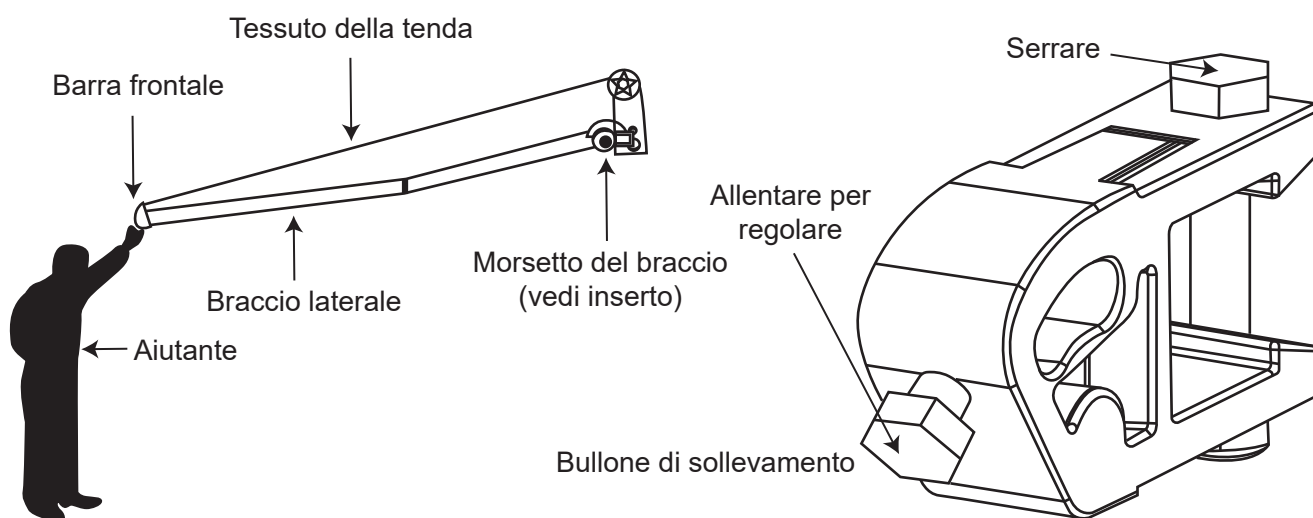

! PERICOLO

L'innalzamento della barra frontale comporta una riduzione dell'angolazione della tenda, con un conseguente rischio di ristagno dell'acqua piovana. Per evitare il crollo della tenda parasole dovuto al peso dell'acqua in caso di pioggia, si raccomanda di chiuderla quando la si lascia incustodita. In caso contrario la tenda potrebbe crollare, con conseguente rischio di danni o lesioni.

Nota: assicurarsi che la barra frontale sia perfettamente dritta. Un allineamento errato comporta un movimento non omogeneo della tenda.

ERRORI FREQUENTI

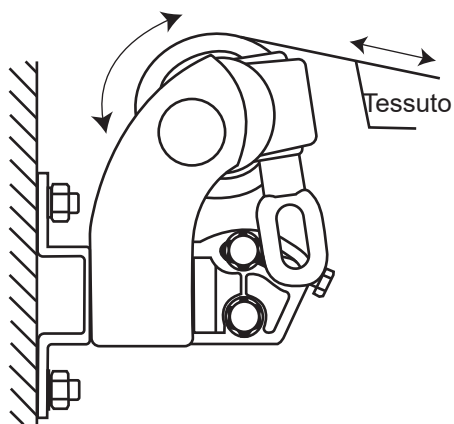

Funzionamento corretto

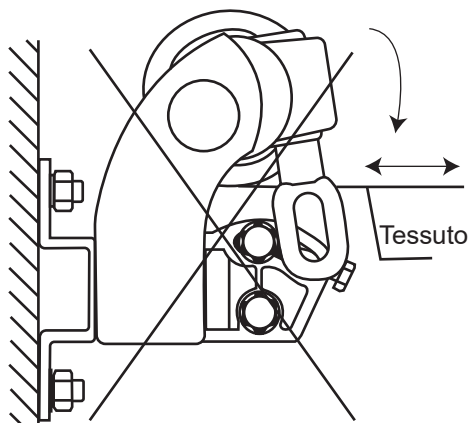

Funzionamento errato

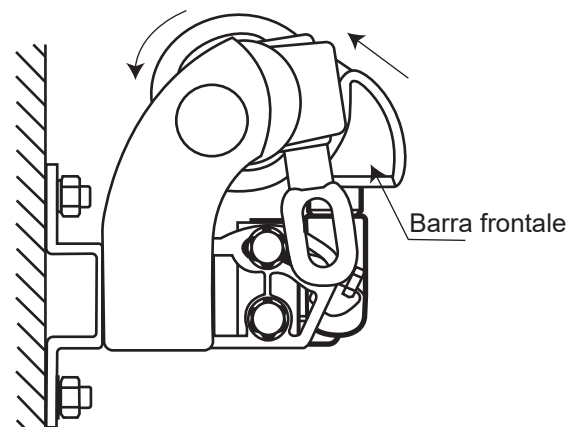

PERICOLO

Quando la barra frontale tocca il rullo come illustrato, non tentare di avvicinarli ulteriormente perché il prodotto potrebbe danneggiarsi.

Persona di contatto
tenulodi S.r.l.
Via Manzano 70
33040 Premariacco (UD)
Numero di telefono: +39 0471 1800175
www.tectake.it
E-Mail: mail@tectake.it