

921-3xx

Lv7 2020-r5

Modelo-model:

Oplus ST

Lote-Lot-Lot-Lot:



Peso-Weight-Poids-Gewicht:

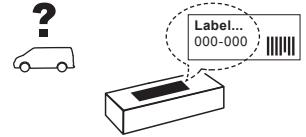

Kit A: **Max. 60 kg**
Kit B: **Max. 75 kg**

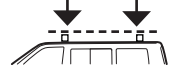

CEE - EEC type approval:

E9 26 R- 04 3015



CITY CRASH (↔)

CRUZBER SA
ES-A14018311
P.I. Las Salinas II
14960 - Rute - Spain
www.cruzber.com

- | | | |
|--------------|---|------------------------|
| (E) | Instrucción de montaje
¡Leer primero! | Barras de acero |
| (GB) | Assembly instructions
Read first! | Steel bars |
| (F) | Instruction de montage
Lire en premier! | Barres d'acier |
| (D) | Montageanleitung
Zuerst lesen! | Stahldachträger |
| (PT) | Instruções de montagem
Ler primeiro! | Barras d'aço |
| (PL) | Instrukcja montażu
Najpierw przeczytaj! | Belki stalowe |
| (CZ) | Montážní návod
Čtěte pozorně! | Ocelové střešní nosiče |
| (HU) | Szerelési Utasítás
Először olvasd el! | Acél rudak |
| (RO) | Instructiuni de montaj
Intai cititi! | Čelične šipke |
| (HR) | Detaljne upute
Prvo procitati! | Bare din otel |
| (GR) | Διαβάστε προσεκτικά τις
Οδηγίες Συναρμολόγησης! | Μπάρες Σιδερέ |
| (TR) | Öncelikle montaj:
Talimatlarını okuyunuz! | Çelik barlar |
| (RU) | Инструкции по монтажу
Сначала прочитайте! | Стальные поперечины |
| (I) | Istruzioni di montaggio
Leggere per primo! | Barre d'acciaio |
| (NL) | Montagehandleiding
Eerst lezen! | Stalen dakdragers |
| (SLO) | Navodila za sestavljanje
Preberite! | Jeklene prečke |



1.

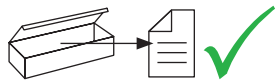

(E) Contenido embalaje: ¡Verificar!

x1

x1

(GB) Package content: Check!



(F) Contenu d'emballage: Vérifier!

(D) Packungsinhalt: Überprüfen!

x2

x1

(PT) Contéudo embalagem:
Verificar!

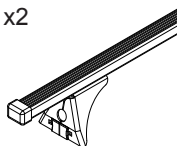

(PL) Zawartość opakowania:
sprawdź!

(853-050)

(CZ) Obsah balení: Zkontrolujte!

(HU) Csomag tartalma: Ellenőrizd!

(RO) Pachetul contine: Verificati!

(HR) Sadržaj paketa: Provjeri!

(GR) Ελέγξτε το περιεχόμενο: του
πακέτου!



(TR) Paket içeriğini: Control ediniz!

(RU) Содержание упаковки:
Проверьте!

(I) Contenuto della confezione:
Controllare!

(NL) Pakket inhoud: Controleer!

(SLO) Vsebina paketa: Preverite!

Código Code		↔		Lote Lot
921-305	ST-110 (822-009)	110 cm	4,867 kg	05/15
921-310	ST-120 (822-019)	120 cm	5,124 kg	06/15
921-315	ST-130 (822-029)	130 cm	5,325 Kg	05/15
921-317	ST-135 (822-034)	135 cm	5,450 Kg	05/15

2.



Importante!
Important!
Important!
Wichtig!

- E** Estas barras tienen que usarse con Kits de fijación Cruz!
- GB** Bars must be used with Cruz fixation Kits!
- F** Les barres devront être utilisées avec les Kits de fixation Cruz!
- D** Die Dachlsträger nur mit Cruz Stützfuß-Kits befestigen!
- PT** As barras devem ser utilizadas com os Kits de fixação Cruz!
- PL** Belki muszą być stosowane z elementó w mocujęcymi firmy Cruz!
- CZ** Tento nosič musí být používán s fixačnīm kitem Cruz!
- HU** A rudakat csak Cruz rögzító készlettel szabad használni!
- RO** Barele trebuie utilizate cu Kit-uri de fixare Cruz!
- HR** Šipke moraju biti korištene sa Cruz kitovima za montažu!
- GR** Το αξεσουάρ αυτό θα πρέπει να χρησιμοποιείται αποκλειστικά στα συστήματα μπαρών της Cruz!
- TR** Bu barlar mutlak Cruz montaj kiti!
- RU** Поперечины должны быть использованы со специальным крепежным комплектом Cruz!
- IT** Questa bare deve essere utilizzato solo con il kit di fissaggio Cruz!
- NL** Dakdragers moeten worden gebruikt in combinatie met de bevestigingssets van Cruz!

3. 

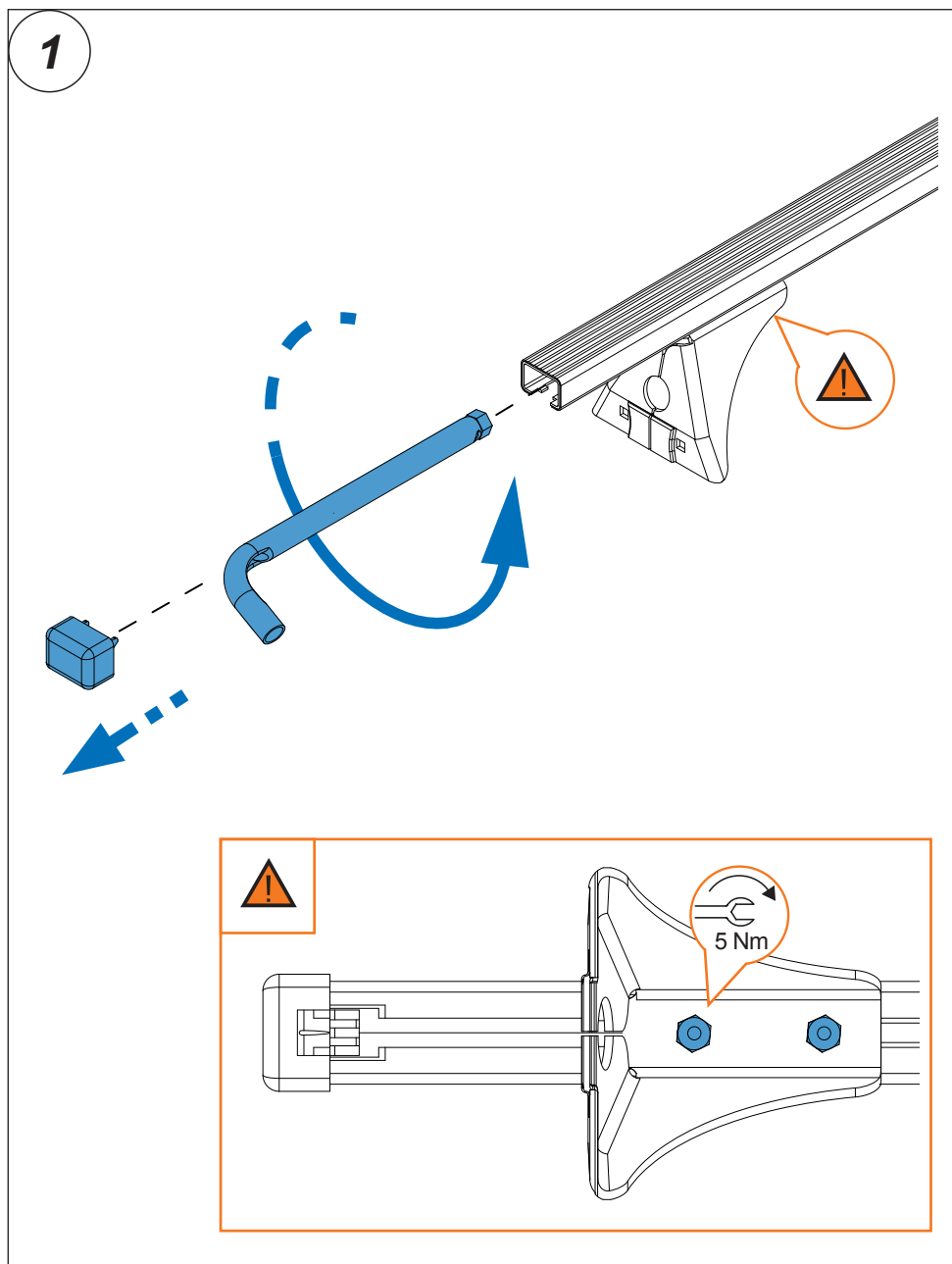

4. 

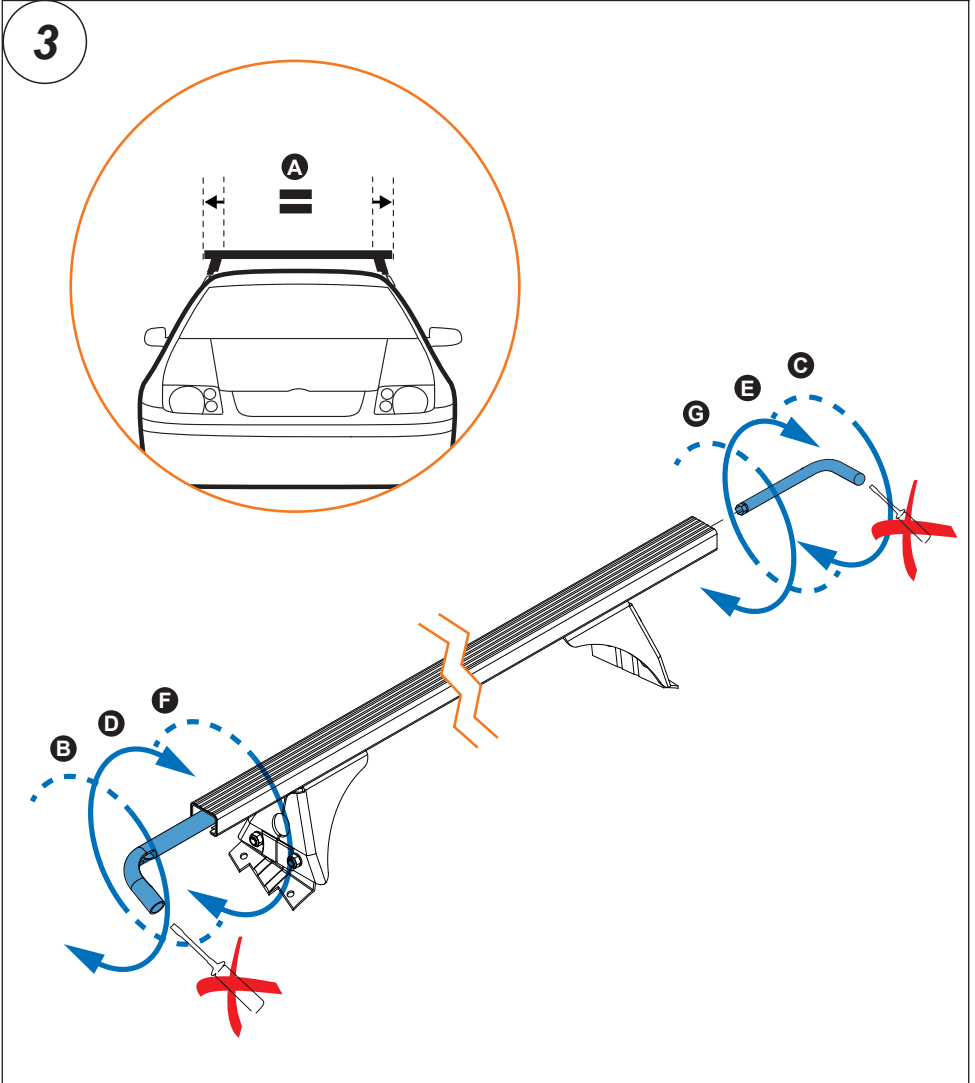
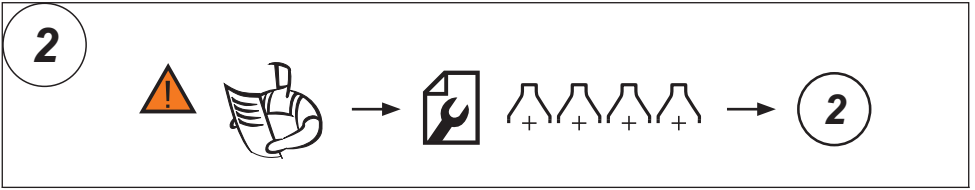

5. 

