

A

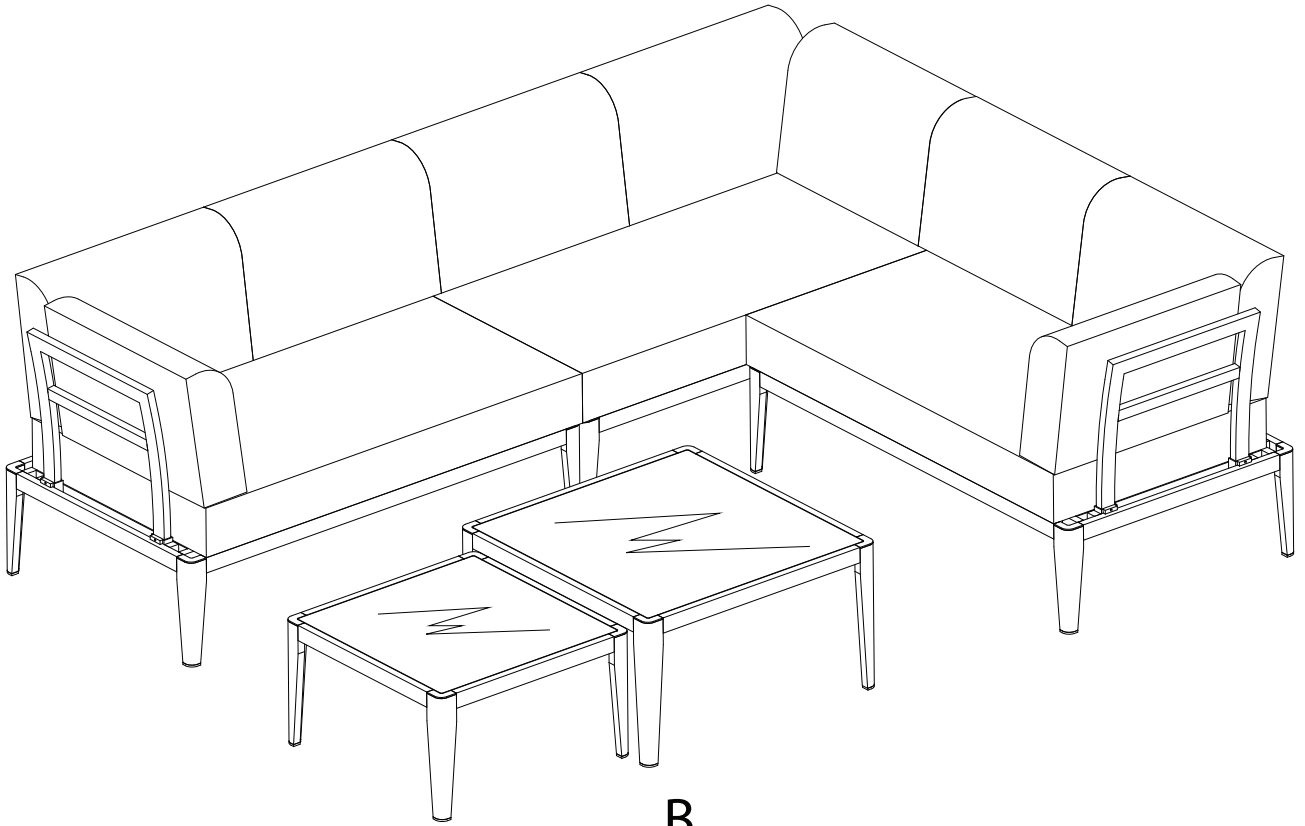
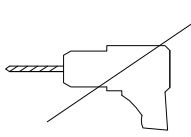

B

! (Warning symbol)

 (Prohibition of drilling)

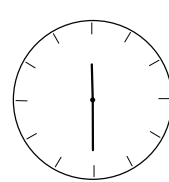
 30' (30 minutes)

! (Warning symbol)

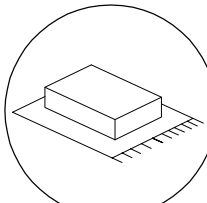
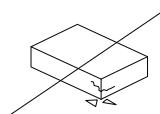
  (Cushions should be placed on a mat, not directly on the floor)

 1 (1 person)

A

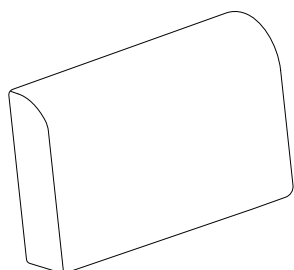
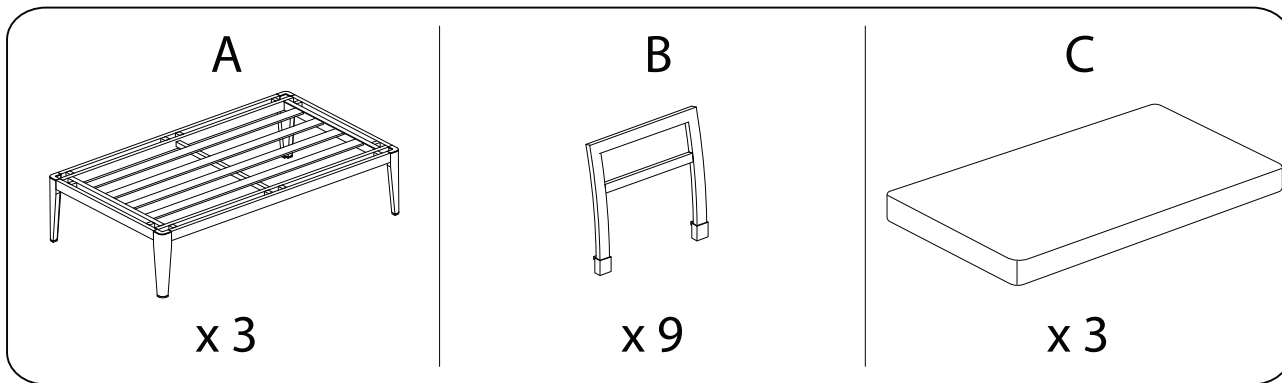

D x 6

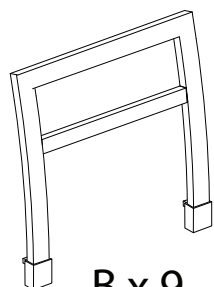

B x 9

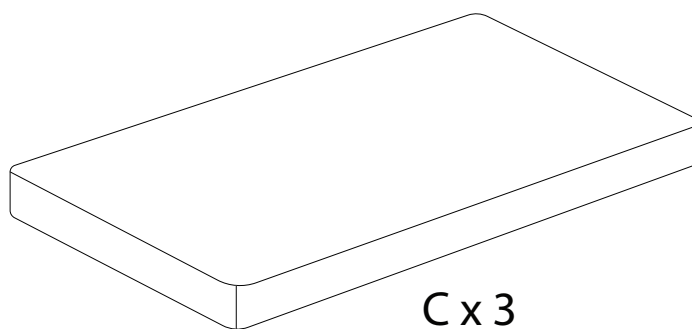

C x 3

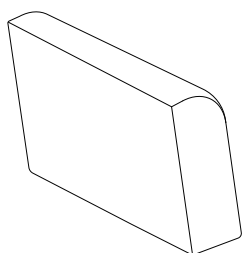

E x 3

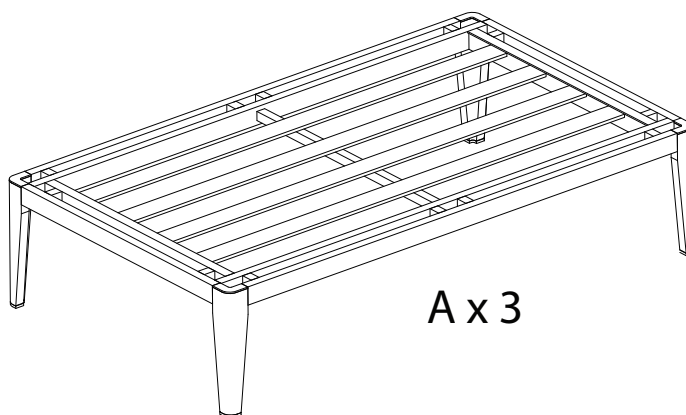

A x 3

D

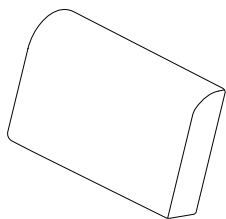

x 6

E

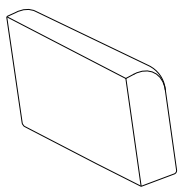

x 3

F

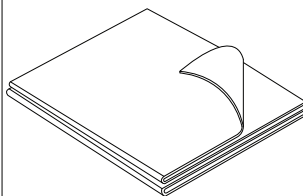

x 6

G

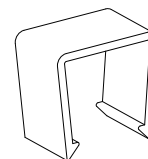

x 4

1 x 3

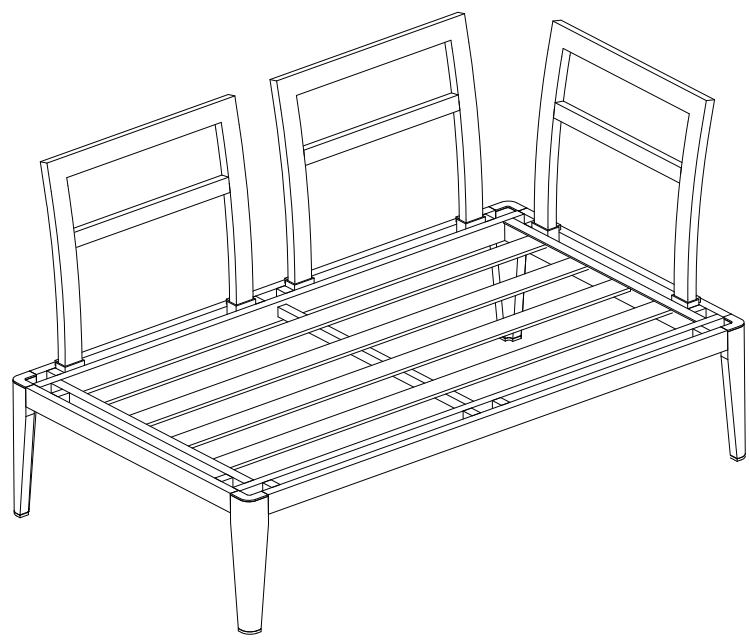
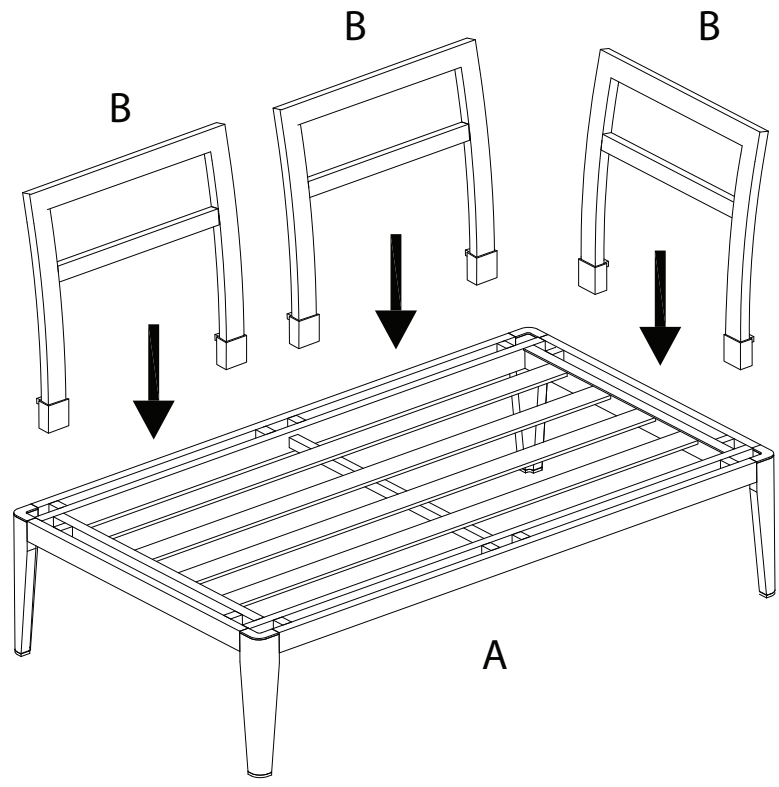
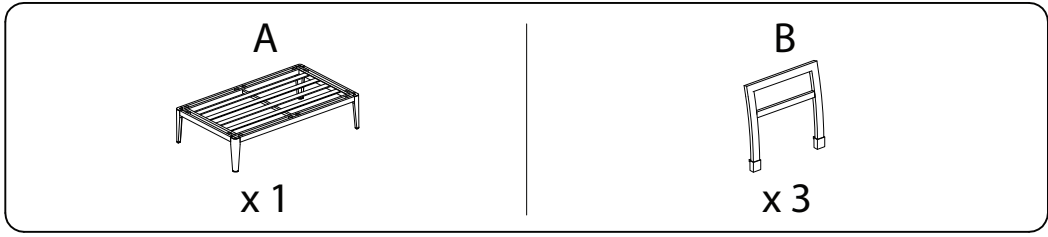

2

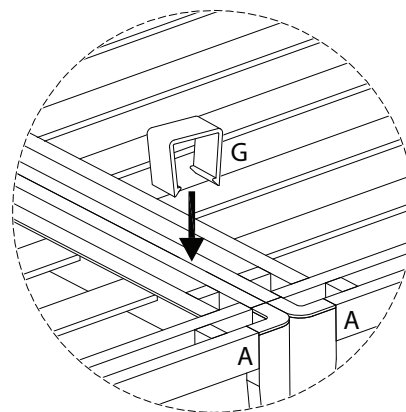
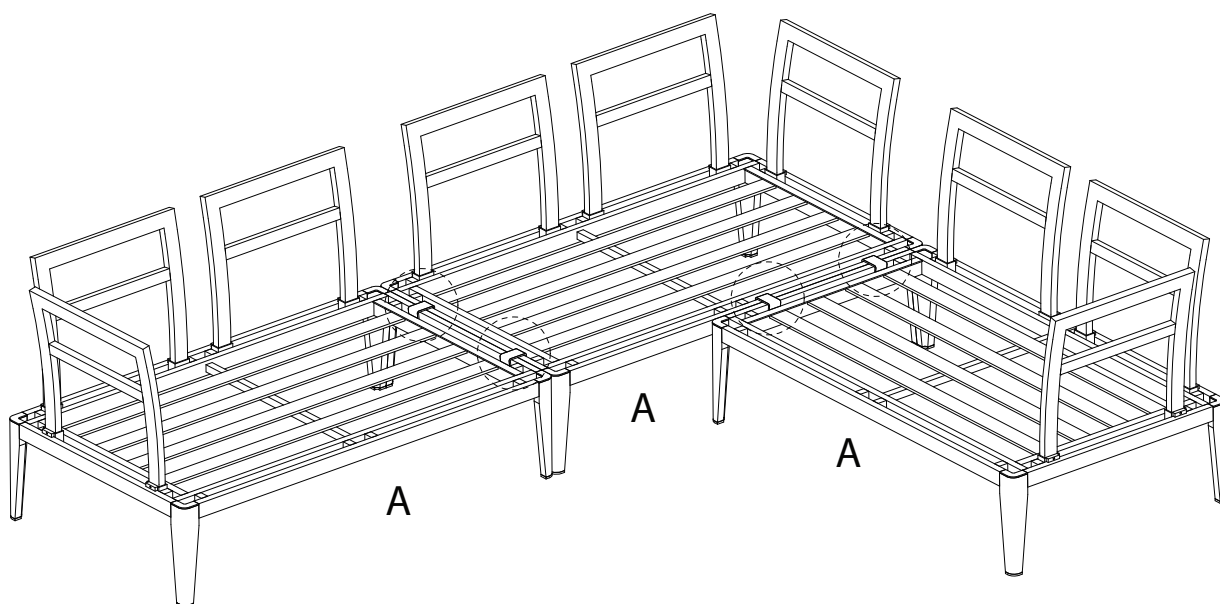
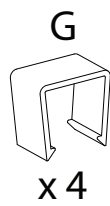

3

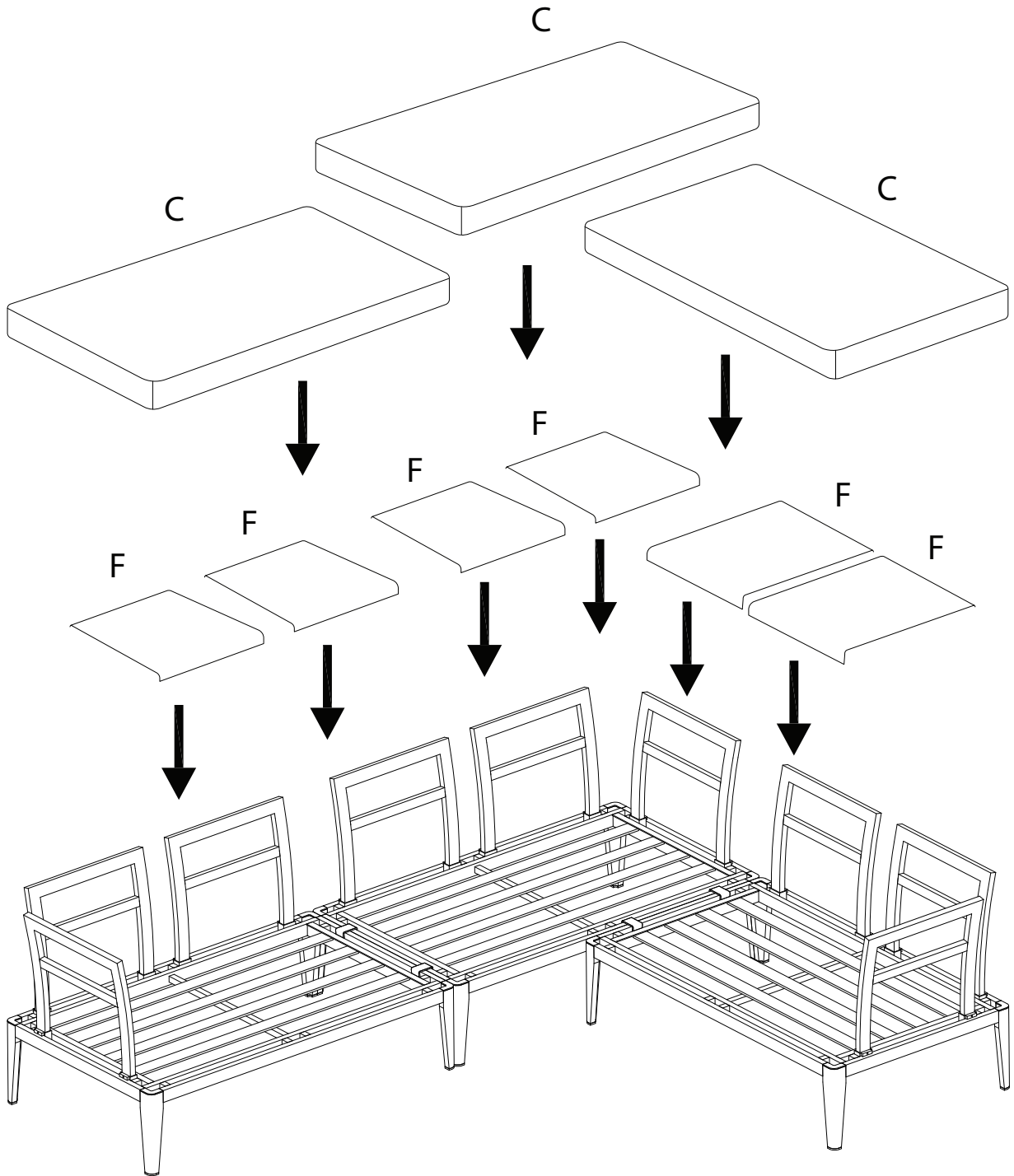
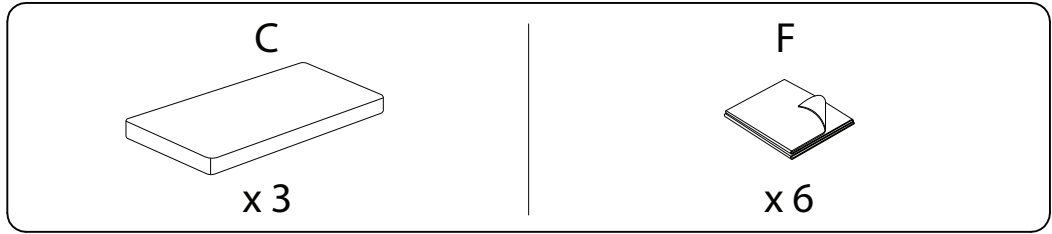

4

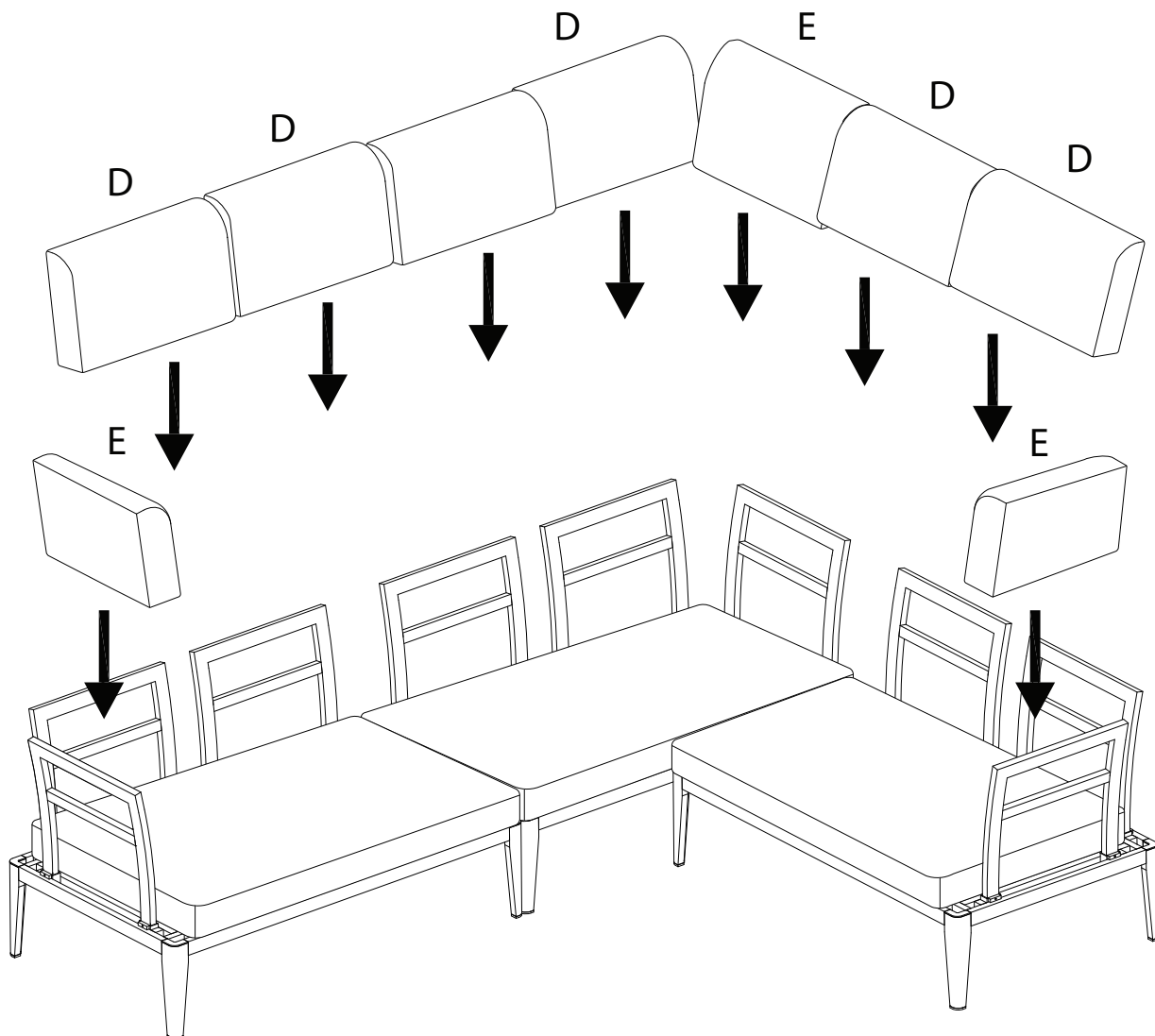
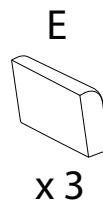
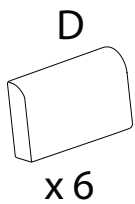

# B

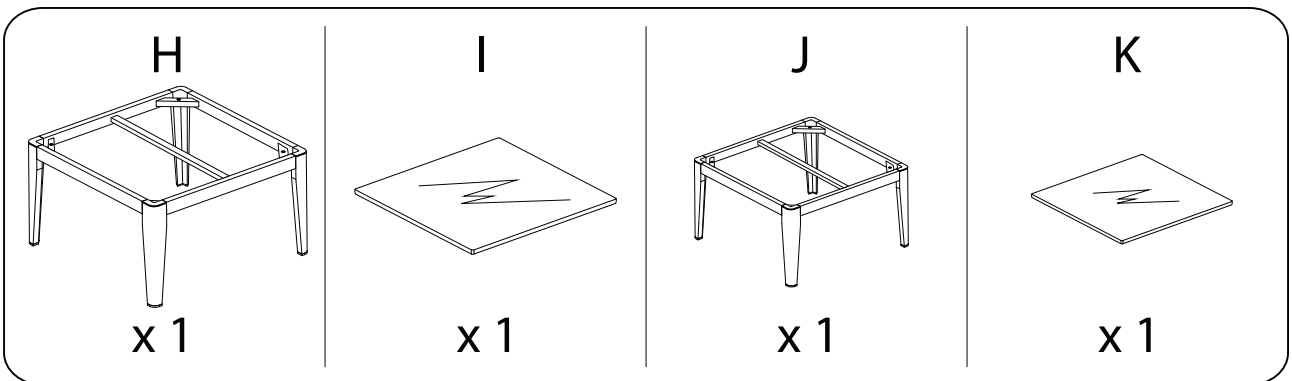
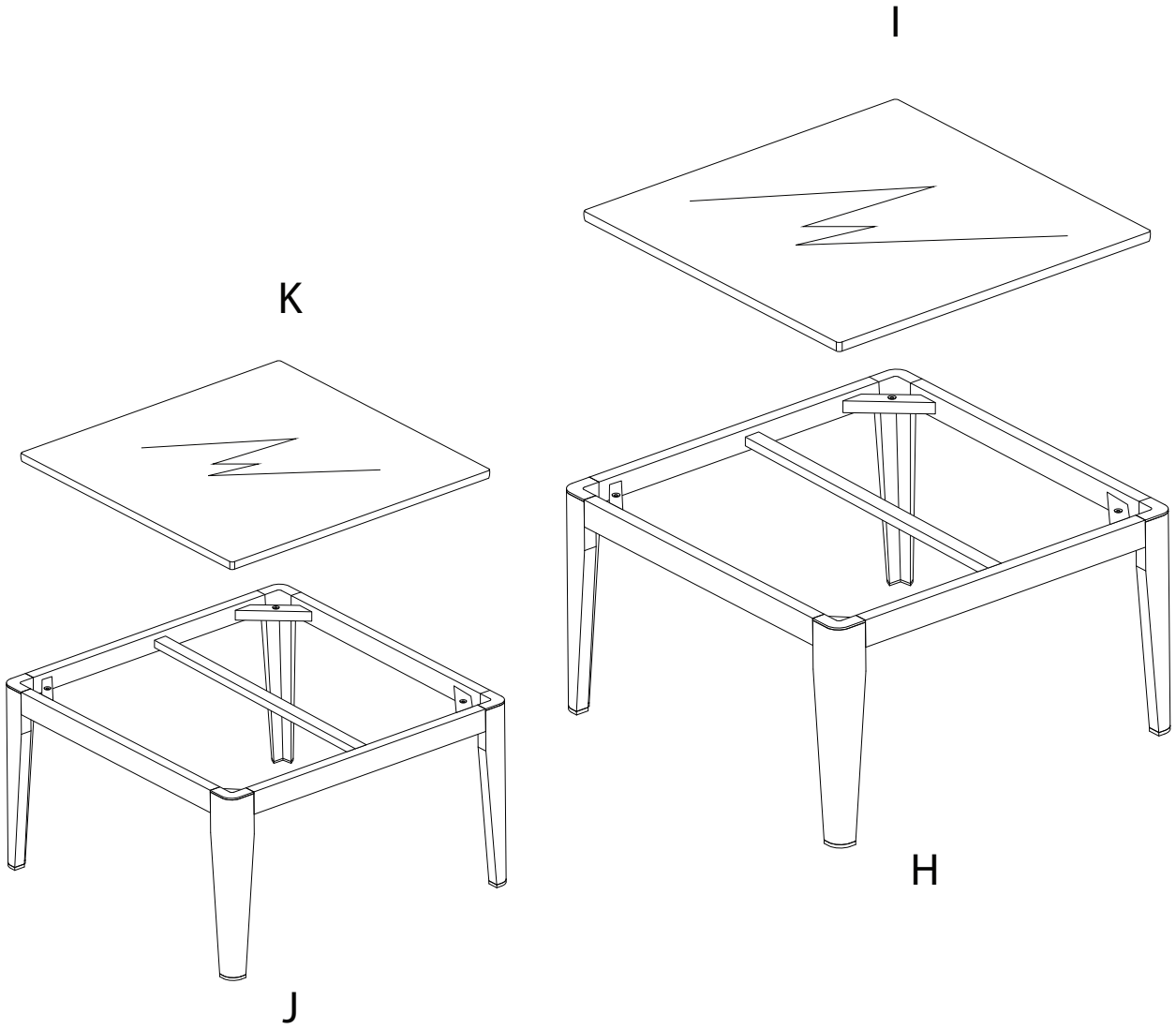

1

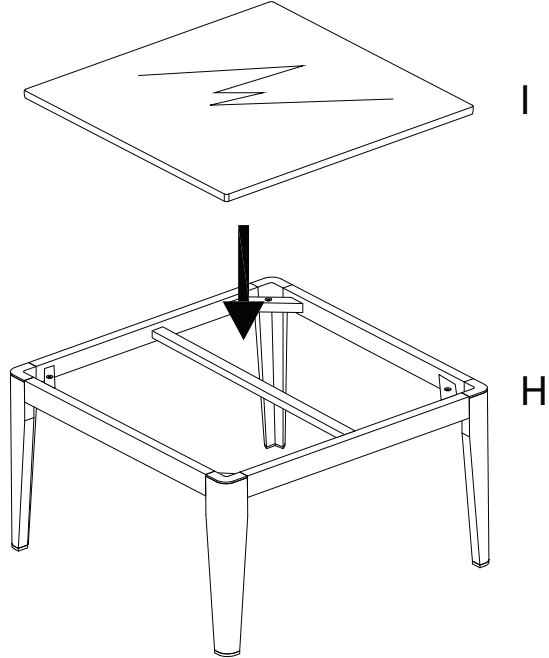
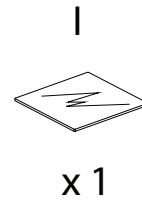
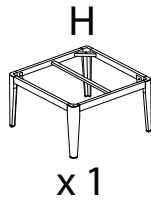

2

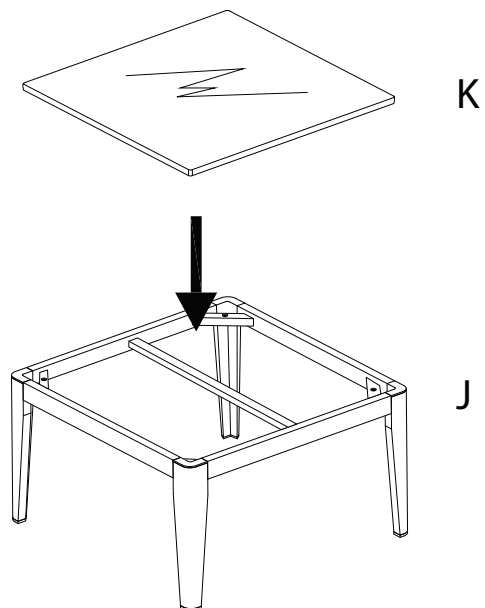
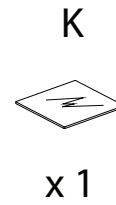
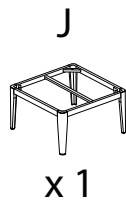



!

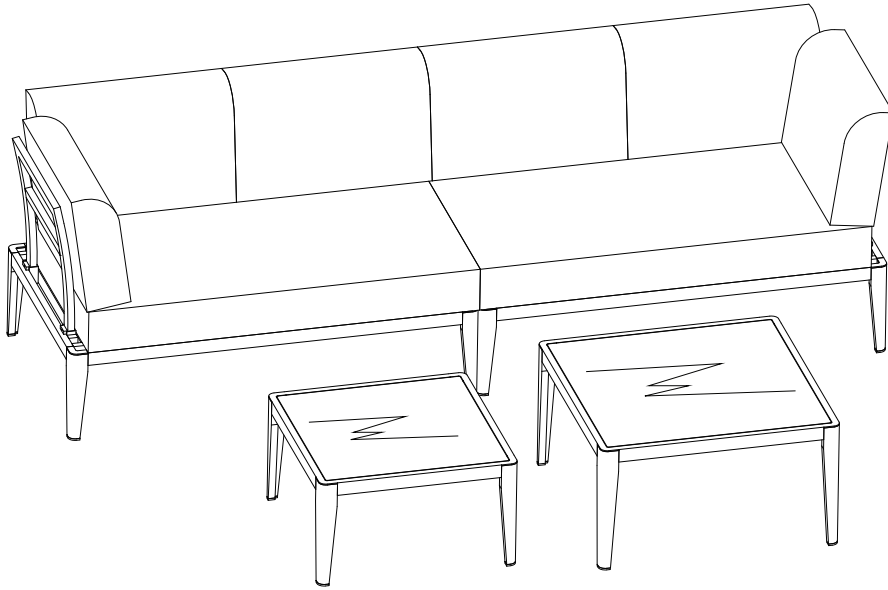

!

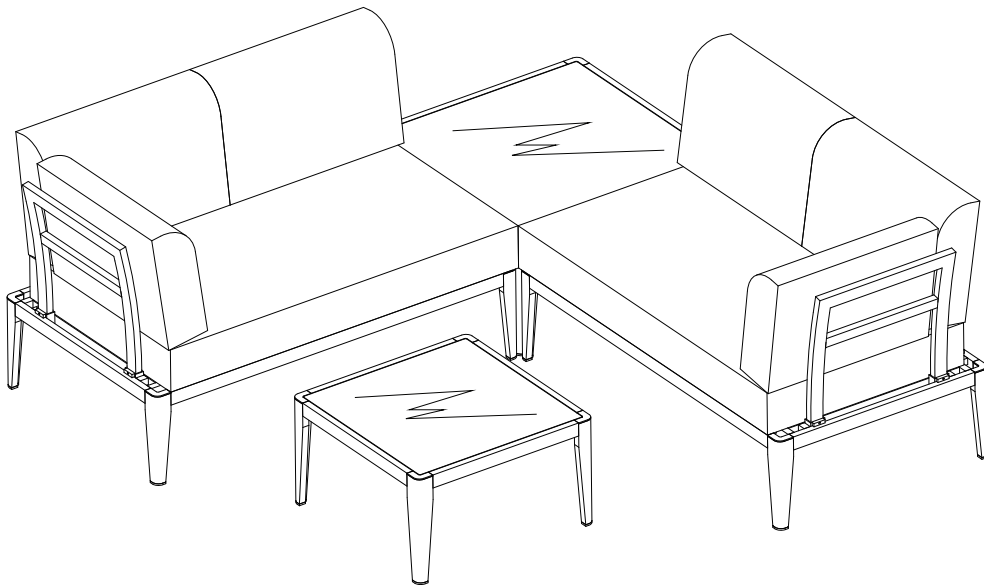

!

