

CHiQ

Refrigerator

MODEL:FBM157L42

CLIMATE CLASS	N/ST
RATED VOLTAGE	220-240V~
RATED CURRENT	0.5A
RATED FREQUENCY	50HZ
INPUT POWER	53W
ENERGY CONSUMPTION OF E ₁₆	0.283kWh/24h
ENERGY CONSUMPTION OF E ₃₂	0.753kWh/24h
LAMP POWER	MAX 10W
REFRIGERATOR STORAGE VOLUME	109L
FREEZER STORAGE VOLUME	48L
INSULATION BLOWING GAS	Cyclopentane
CLASS OF PROTECTION AGAINST ELECTRIC SHOCK	Class I
REFRIGERANT/AMOUNT	R600a/41g
FREEZING CAPACITY	2.2kg/24h
TEMPERATURE RISE TIME	9h
NET WEIGHT	33.8Kg
PRODUCT DIMENSIONS(W*D*H)	474x495x1440mm

Diagram of Circuit Principles

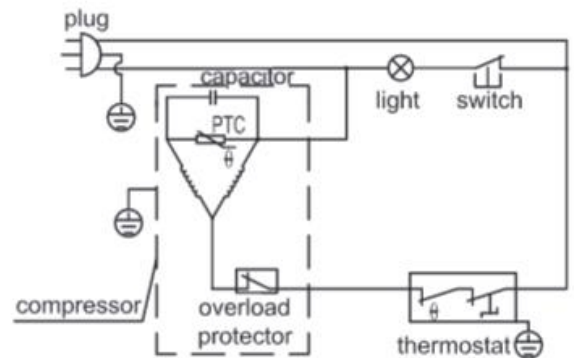

Made in PRC

Serial Number: 印序列号



68 mm

98 mm