

# Cyrix Li-ion 120 A series

www.victronenergy.com



Cyrix-Li-load 12/24-120



Cyrix-Li-Charge 12/24-120



Cyrix-Li-ct 12/24-120

## The LiFePO4 battery: preventing cell under voltage, over voltage and over temperature

The first line of protection is cell balancing. All Victron LiFePO4 batteries have integrated cell balancing. The second line of protection consists of:

- shut down of the load in case of imminent cell under voltage, and
- shut down or reduction of the charging current in case of imminent cell over voltage, high temperature (>50°C) or low temperature (<0°C).

The VE.Bus BMS is the core of the second protection line.

However, not all loads or chargers can be controlled directly by the VE.Bus BMS.

In order to shut down such loads or chargers several VE.Bus BMS controllable Cyrix switches are available.

### Cyrix-Li-load

The Cyrix-Li-load will disengage when its control input becomes free floating.

If the battery voltage recovers after disconnecting (which will happen when no other loads are connected to the battery), the output of the BMS will become high and the Cyrix will reengage after 30 seconds. After 3 attempts to reengage, the Cyrix will remain disengaged until battery voltage has increased to more than 13V (resp. 26V or 52V) during at least 30 seconds (which is a sign that the battery is being recharged).

**Alternatively, a BatteryProtect can be used (advantage: very low power consumption).**

### Cyrix-Li-Charge

The Cyrix-Li-Charge will connect a battery charger with 3 seconds delay:

- if the Charge Disconnect output of the VE.Bus BMS is high, and
- if it senses 13,7V (resp. 27,4V or 54,8V) or more on its battery charger connection terminal, and
- if it senses 2V or more on its battery terminal (the Cyrix will remain open, if not connect to the battery).

The Cyrix-Li-Charge will disengage immediately whenever its control input becomes free floating, signalling cell over voltage or cell over temperature.

In general a cell over voltage alarm will reset shortly after charging has been stopped. The Cyrix will then reconnect the charger after a delay of 3 seconds. After two attempts to reengage with 3 seconds delay, the delay increases to 10 minutes.

Whenever battery voltage is less than 13,5V (resp. 27V or 54V), the Cyrix will disengage with a delay of 1 hour.

Note 1: In case of zero discharge current, or a small discharge current, the Cyrix will not disengage shortly after the charger has been switched off and/or disconnected, because battery voltage will remain higher than 13,5V.

Note 2: If, after the Cyrix has disengaged, the output of the battery charger immediately increases to 13,7V or more, the Cyrix will re-engage, with 3 seconds delay.

### Cyrix-Li-ct

The functionality of the Cyrix-Li-ct is analogous to the Cyrix-ct.

The Cyrix-Li-ct will parallel connect a lead acid starter battery and a LiFePO4 battery:

- if the Charge Disconnect output of the VE.Bus BMS is high, and
- if it senses 13,4V (resp. 26,8V) or more on one of its power terminals.

The Cyrix will disengage immediately:

- when its control output becomes free floating, signalling cell over voltage or cell over temperature, and/or
- when battery voltage drops below 13,2V.

Start assist function: a short positive pulse will close the relay during 30 seconds (see figure on page 2).

A built-in transient voltage suppressor will limit the voltage spike that may occur when the Cyrix suddenly disengages due to cell overvoltage or over temperature.

Cyrix Battery Combiner	Cyrix-Li-load 12/24-120	Cyrix-Li-Charge 12/24-120	Cyrix-Li-ct 12/24-120	
	Cyrix-Li-load 24/48-120	Cyrix-Li-Charge 24/48-120	12V system	24V system
Continuous current and breaking capacity at 12V or 24V	120A	120A	120A	
Breaking capacity at 48V	40A	40A	n. a.	
Control input	The Cyrix engages when the control input is high (appr. Battery voltage) The Cyrix disengages when the control input is left free floating or pulled low			
Connect voltage	See text	13,7V / 27,4V / 54,8V	13,4V < V < 13,7V: 120 s 13,7V < V < 13,9V: 30 s V > 13,9V: 4 s	26,8V < V < 27,4V: 120 s 27,4V < V < 27,8V: 30 s V > 27,8V: 4 s
Disconnect voltage	See text	See text	13,3V < V < 13,2V: 10 s V < 13,2V: immediate	26,6V < V < 26,4V: 10 s V < 26,4V: immediate
Current consumption when open	<4 mA			
Protection category	IP54			
Weight kg (lbs)	0,11 (0.24)			
Dimensions h x w x d in mm (h x w x d in inches)	46 x 46 x 80 (1.8 x 1.8 x 3.2)			

## Connection diagrams

Cyrix-Li-load

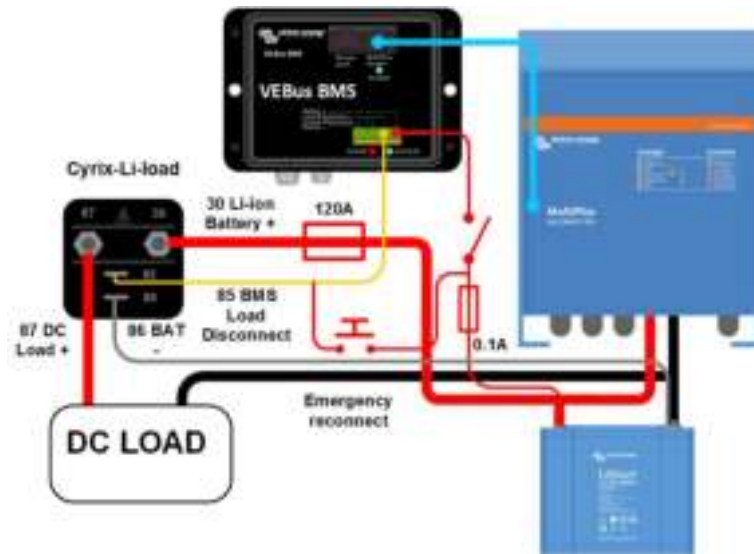

Cyrix-Li-Charge

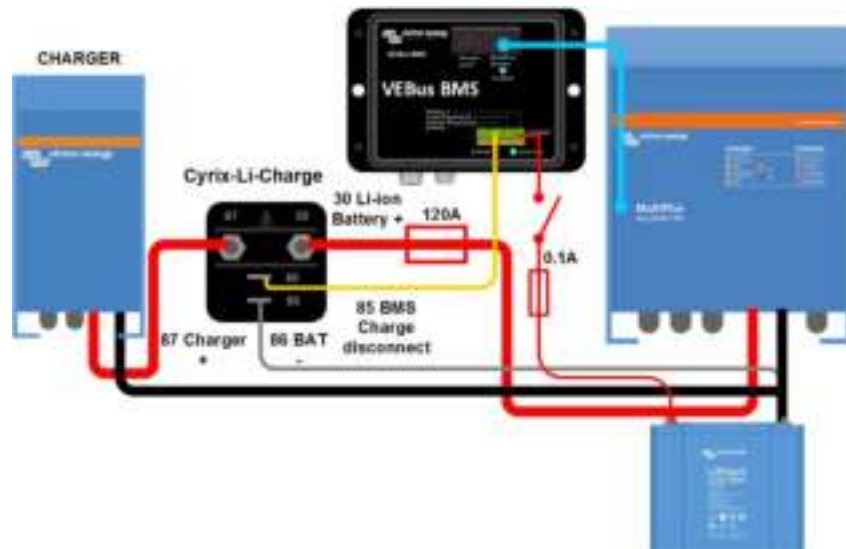

Cyrix-Li-ct

