

ortofon



accuracy in sound

2M



ortofon

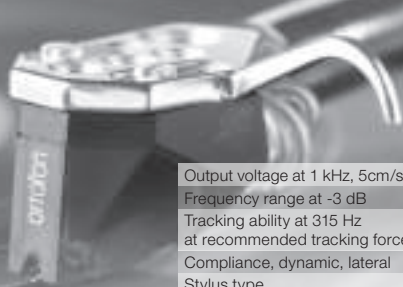

2M 78 /
2M 78 Verso



2M Mono /
2M Mono Verso



2M Red /
2M Red Verso



2M Blue /
2M Blue Verso



2M Bronze /
2M Bronze Verso



2M Black /
2M Black Verso

Output voltage at 1 kHz, 5cm/sec.	4 mV	4 mV	5,5 mV	5,5 mV	5 mV	5 mV
Frequency range at -3 dB	20-20.000 Hz	20-22.000 Hz	20-22.000 Hz	20-25.000 Hz	20-29.000 Hz	20-31.000 Hz
Tracking ability at 315 Hz at recommended tracking force	70 µm	70 µm	70 µm	80 µm	80 µm	80 µm
Compliance, dynamic, lateral	18 µm/mN	18 µm/mN	20 µm/mN	20 µm/mN	22 µm/mN	22 µm/mN
Stylus type	Spherical	Nude Spherical	Elliptical	Nude Elliptical	Nude Fine Line	Nude Shibata
Tracking force recommended*	1,8 g (18 mN)	1,8 g (18 mN)	1,8 g(18 mN)	1,8 g(18 mN)	1,5 g (15 mN)	1,5 g (15 mN)
Load resistance*	47 kOhm	47 kOhm	47 kOhm	47 kOhm	47 kOhm	47 kOhm
Load capacitance*	150-300 pF	150-300 pF	150-300 pF	150-300 pF	150-300 pF	150-300 pF

*Recommended

About the Ortofon 2M Series cartridges

Thank you for choosing the Ortofon 2M magnetic cartridge system for high performance sound reproduction of your favourite analogue records.

Our company has been working with sound reproduction since 1918. Ortofon developed its first phono cartridge in 1948, since then more than 300 different phono cartridges have been developed and manufactured. Reflecting our extensive experience in industrial design and technological know-how we have become the global leader in the manufacture and supply of phono cartridges.

The 2M Series has been engineered in accordance with the highest standards and is congruent with Ortofon's unrelenting commitment to providing the most precise and accurate reproduction possible without coloration.

The 2M Series comprises of two configurations: 2M for top mounting and 2M Verso for bottom mounting. Each configuration consists of 2M 78, Mono, Red, Blue, Bronze and Black models, which weight and size have been optimized to fit the most common turntables on the market to-day.

As a result of reviewer listening tests we feel confident that you will appreciate and enjoy the unique qualities of these cartridges.

ortofon

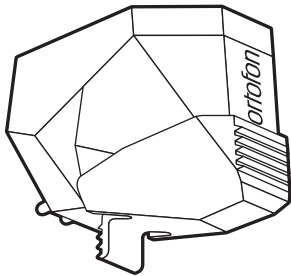

2M

Mounting the 2M cartridge

1. Remove stylus unit with stylus guard before working with leads and screws. Handle all parts carefully. (fig. 1-2)

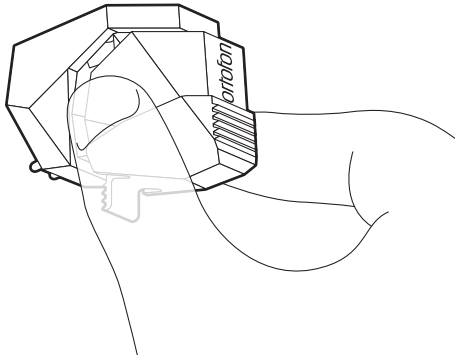

Fig. 1

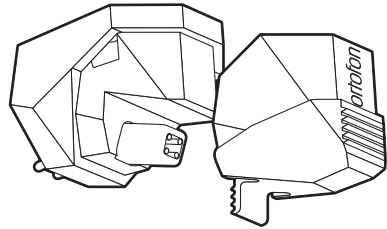

Fig. 2

2. Note colours and channel indications on rear side of the body for correct connection of the tone arm leads. (fig. 3)

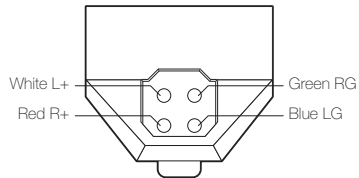

Fig. 3

3. The Ortofon packing contains a pair of screws with a thread length of 5 mm. The screws are to be used with headshell thicknesses of max. 3.5 mm. The 2M threaded mounting plate has a thickness of 3 mm.

2M top mount

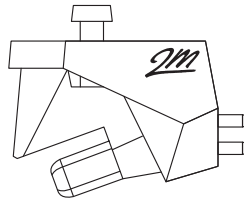
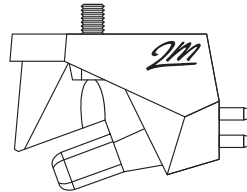

Fig. 4

To check that you are using the right length of screws – please observe that screws must not touch the body under the mounting plate – look into the small openings on each side of the body. (fig. 4)

2M Verso bottom mount



Do not tighten screws completely before the stylus unit has been remounted (fig. 1) – to adjust stylus overhang refer to the record player or tone arm manual and cartridge dimensions. (fig. 5)

Never overtighten screws and never use aluminium screws, as they can get stuck in the threaded holes of the mounting plate.

Note: If excessively long screws are used and are pressing against the body material, this may influence channel separation and could damage the cartridge body. In case of such damage the Ortofon warranty will be void.

4. Adjust tone arm parallel to record surface, adjusting anti-skating and stylus pressure according to cartridge recommended data and record player manual.

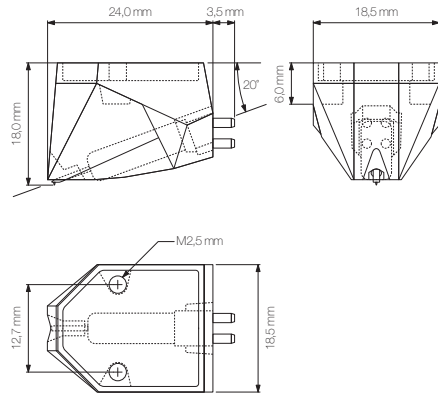

Fig. 5

Stylus care and maintenance

To obtain optimal sound reproduction, remove dust from stylus regularly by using the enclosed small brush.

If the headshell can be easily removed from the tone arm, we recommend that you turn the diamond upwards and brush gently forward in the direction of the diamond tip along the cantilever.

We do not recommend the use of propyl alcohol (or other cleaning fluids) for cleaning the cartridge, as the diamond cement as well as the suspension system could be seriously damaged and thereby ruin the cartridge.

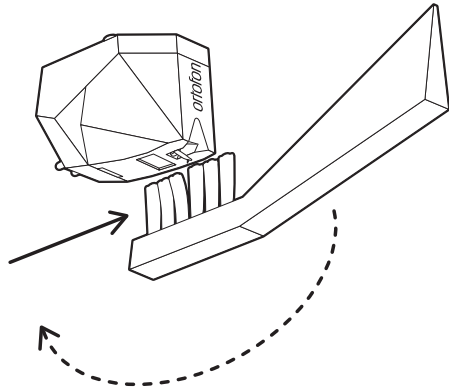

Fig. 6

Stylus guard

Remove the stylus guard before use by holding at the front and rear of the guard and gently pressing the rear while tilting it downwards. (fig. 7-8)

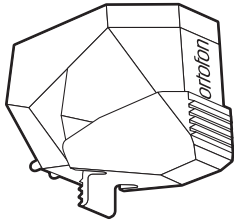

Fig. 7

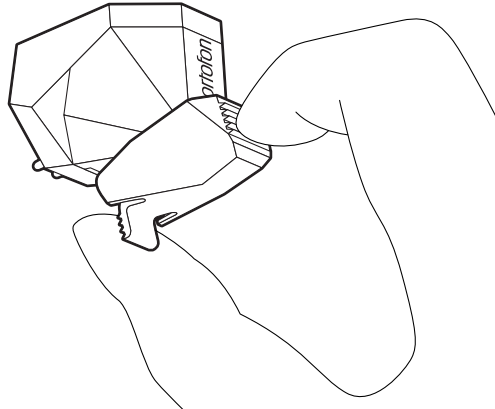

Fig. 8



Get more information
about 2M cartridges.

ortofon
accuracy in sound

Ortofon A/S | Stavangervej 9 | DK-4900 Nakskov
Tel. +45 54 91 19 15 | www.ortofon.com