

Silver **series**
o w n e r s m a n u a l

Contents

Contents	1
Introduction	2
Silver 1	3
Silver 2	3
Silver 6	3
Silver 8	3
Silver 10	3
Silver Centre	3
Silver FX	3
Setting Up	4
AV Positioning	4
Optimum AV Speaker Positioning	4
Silver FX Switch Configuration	5
2 Channel Positioning	7
Setting up the Silver FX	7
Fixing the Silver FX to a wall	8
Plinth Fixing	8
Grilles	8
Spiked Foot	9
For Carpeted Floors	9
For Wooden/ Hard Floors	9
Connecting Speaker Cables	10
Bare Wire Connection	10
Single Wire	10
Banana Plugs	10
Bi-Wire/ Bi-Amp	10
Port bungs	11
Running In	11
Specifications	12

Introduction

With the extraordinary success of RX as its blueprint, the latest Silver Series advances the art of mid-market speaker development with new models and technologies. Features introduced by the prestigious Platinum and Gold series speakers have been refined, and recent innovations in driver engineering incorporated across an extended new Silver series. While the Silver 1, 2, 6, centre and FX retain the form factor of their predecessors, the Silver 8 becomes a full three way design, and new to the Silver family, the Silver 10 offers an up-scaled floor-standing format, featuring twin 8" bass drivers for a deeper more dynamic and consistent response in larger rooms.

New bass and mid-range drivers

Unlike conventional cones, which incorporate a centre aperture for the voice-coil, the dimpled RST® (Rigid Surface Technology) C-CAM® cones deployed by the Silver Series take the form of a continuous uninterrupted radiating dish having inherently greater strength and area. The voice coil sits beneath and is coupled to a larger motor by an innovative, more efficient drive assembly.

In addition, the Silver 8 and 10 models feature a newly developed 4" mid-range driver, operating in its own damped and optimised enclosure to provide accurate mid frequencies. It features a short voice coil 'under-hung' in relation to the magnetic gap to ensure that the coil remains inside the gap at all times for significantly reduced modulation and extremely low distortion.

New tweeter

Distortion from air compression at the back of a tweeter dome has been eliminated by Silver's new 25mm C-CAM tweeter design, which vents into a large rear-loading chamber, producing much lower resonance and better overall damping. The frequency response from the new tweeter is more accurate at lower frequencies for a smoother more natural handover with the mid/bass driver. Meanwhile high frequency extension has been improved and break-up reduced by improvements in cone geometry and drive mechanism.

Other design features

The new Silver Series retains the single bolt-through driver fixings deployed by RX to reduce cabinet colouration. Each bolt acts as a rigid brace, but also removes the need for conventional driver fixings as well, effectively decoupling the driver and front baffle to eliminate a further source of resonance.



NOTE: Should this bolt become loose over time, or has worked loose during transit, then please use the supplied hex key to tighten the bolt back up. This only needs to be a quarter turn on after the strain has been taken by the bolt.

Evolving from Platinum, Monitor Audio's HiVe port technology is incorporated on all but Centre, FX and W12 subwoofer models. HiVe uses a straight rifled design to accelerate air flow and reduce turbulence for clean powerful bass and superior transient response. Polypropylene film capacitors, air core and laminated steel core inductors have been utilised in the crossovers to maintain the best possible signal integrity. All models in the new Silver Series offer higher sensitivity, reduced distortion and higher impedance than their predecessors, ensuring a wider choice of partnering equipment.

Silver 1

The compact new Silver 1 features a single 6" C-CAM® bass/mid-range driver featuring dimpled RST cone technology in a classic two-way monitor configuration. High output and dynamic delivery make the Silver 1 an ideal choice for small to medium rooms in two-channel stereo or multi-channel cinema systems.

Silver 2

The Silver 2 features a powerful 8" C-CAM, RST bass/mid driver in a compact two-way stand mount design. Higher overall efficiency and driver size delivers excellent dynamic headroom with the extended bass normally associated with floor-standing models. Exceptional resolution combined with high output and remarkable dynamic delivery mean that the Silver 2 is suitable for medium to large rooms in two-channel stereo or multi-channel cinema systems.

Silver 6

The Silver 6 incorporates a 6" C-CAM, RST bass driver and 6" C-CAM RST bass/mid driver in a 2.5 way system configuration. The drivers are housed in separate acoustic chambers within the enclosure design to provide differential tuning for higher efficiency and enhanced low frequency extension. Excellent dynamics combined with a naturally rhythmic sonic character and tight, controlled bass make the Silver 6 an outstanding communicator of music and film audio.

Silver 8

The Silver 8 has a new three-way design featuring Silver's 4" C-CAM, RST mid-range driver flanked by long-throw C-CAM, RST 6" bass drivers. Introduced for Silver, this specialised configuration is optimised for greater accuracy over a critical frequency band to deliver superb mid-range focus and precision as well as extended bass. A taller, shallower cabinet and improved damping allows for greater room position flexibility, while higher sensitivity and impedance make the Silver 8 easier to drive for room-filling dynamics, even in larger spaces.

Silver 10

Silver 10 is a completely new model introduction, comprising a three-way configuration in a large floor-standing tower system. For Silver 10 the 4" C-CAM, RST mid-range driver is flanked by 8" C-CAM, RST long-throw bass drivers. The acoustic design is similar to the Silver 8 but the enhanced driver size means that the 10 is equipped to energise the largest of rooms with naturally explicit wideband audio from music and film sources.

Silver Centre

The compact Silver Centre features twin 6" C-CAM, RST bass/mid-range drivers in a familiar Mid - Tweeter - Mid array. The Silver Centre has been tuned to match the tonal character of its Silver range mates for a seamless front sound stage in multi-channel applications.

Silver FX

The discreetly profiled angled baffle design of the new Silver FX surround speaker incorporates a single front-mounted 6" C-CAM, RST bass/mid driver and twin side-mounted C-CAM tweeters. It can be flush-mounted on side or rear walls and its dispersion characteristics changed at the flick of a switch for di-pole or bi-pole operation.

Setting Up AV Positioning

The illustrations on the following pages show optimal positioning and some suggested room layouts for AV applications. For advice on configuring a 2 channel system, refer to page 7.

The front, and in some cases rear, floor standing and stand mount speakers should be positioned approx 6 - 9 feet apart (1.8m - 2.5m) and start with them about 10 inches (25cm) from the wall.

If, when playing music, the sound is too bass heavy or there is bass boom from the room, then move them slightly further away from the rear/ side walls. If this is not possible, then try the supplied port bungs (not included in the Silver FX or Centre). Refer to Page 11.

The Centre should be positioned so that it is pointing at you in your viewing position, and at approximate ear height. If it is below or above ear height, use some rubber feet (small feet supplied) to angle it slightly.

The FX's should be positioned in accordance with the below illustrations and approx 2 feet (60cm) above ear height when in your listening position. Refer to page 7 for further information.

Optimum AV Speaker Positioning

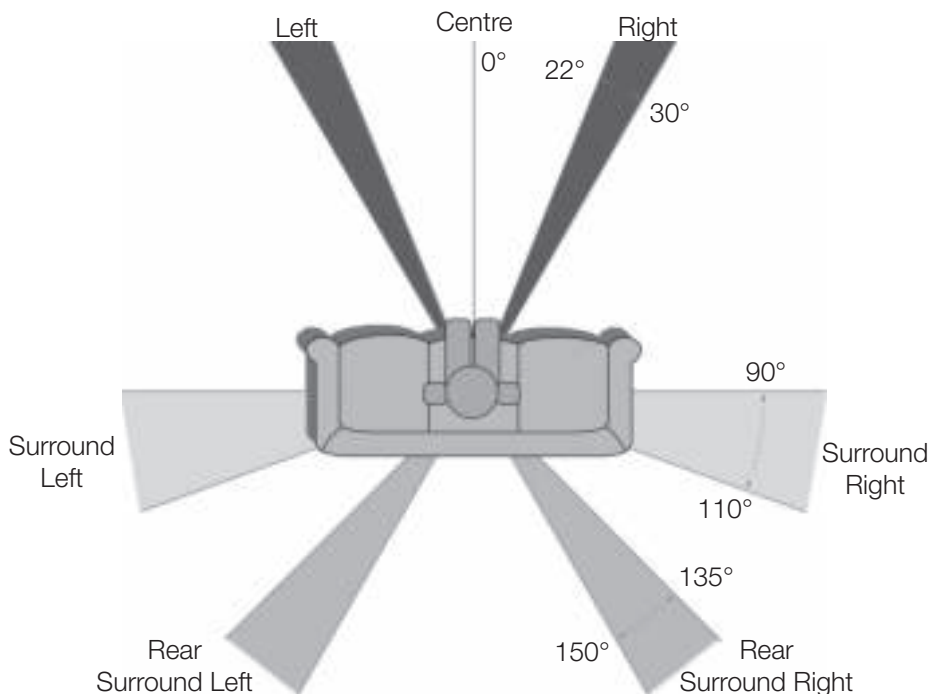

Silver FX Switch Configuration

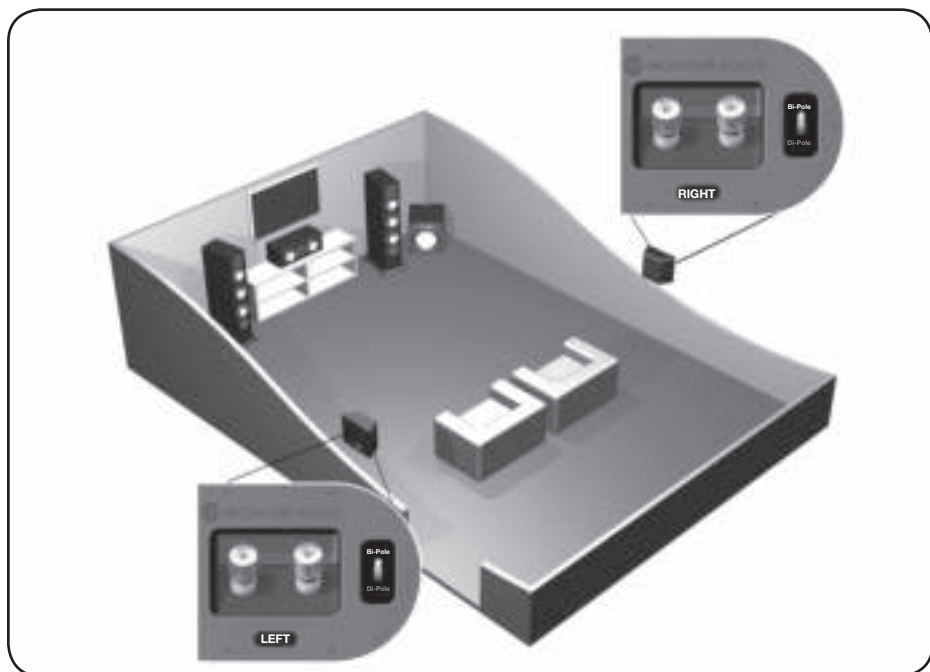
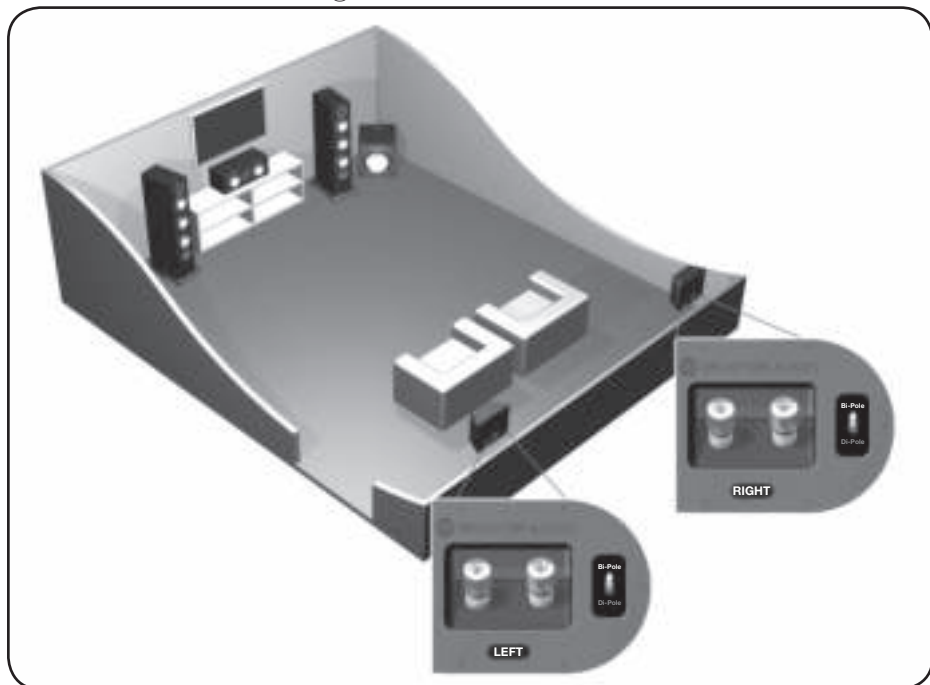

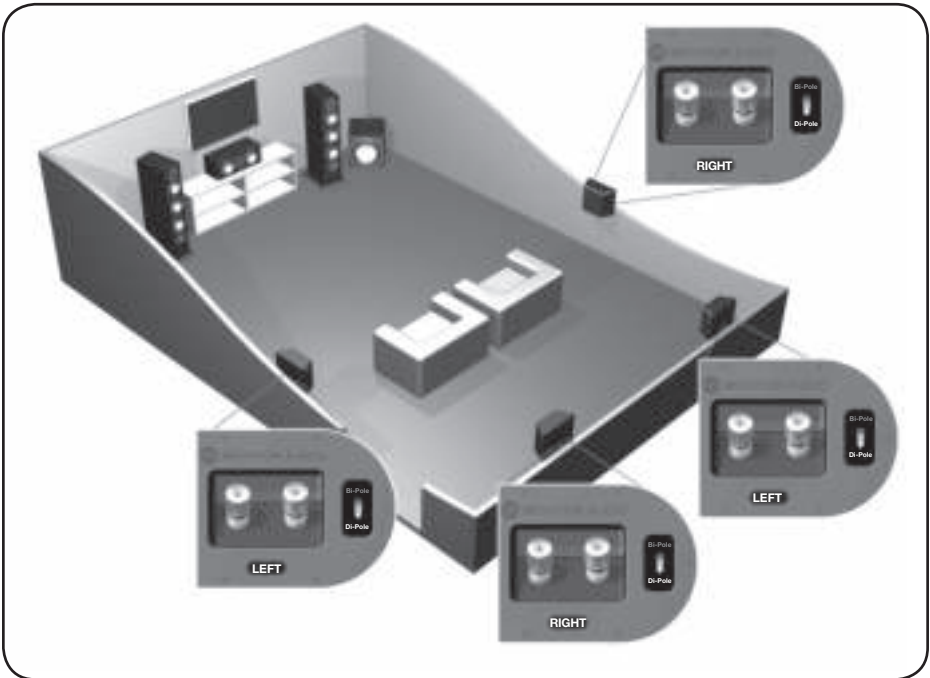
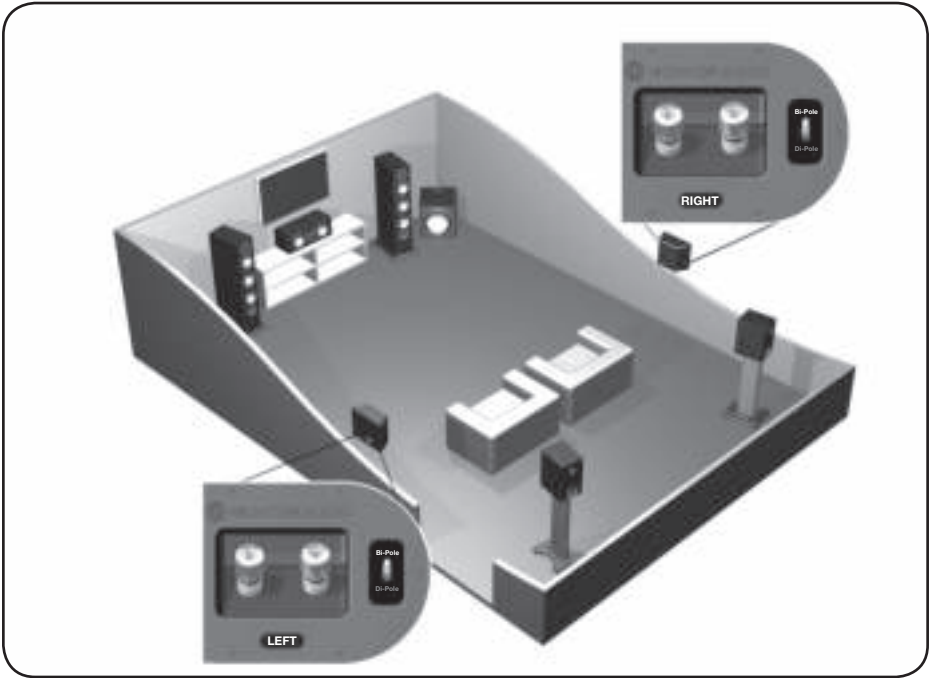

2 Channel Positioning

For use in a 2 channel system, the listening position and the loudspeakers should form an equilateral triangle. The speakers should be positioned approximately 6 - 10 feet (1.8 - 3m) apart. They ideally need to be between 8 - 18 inches (20 - 45cm) away from the rear and 3 feet (1m) from the side walls.

Experimentation is strongly advised when initially setting up your speakers, as environments and personal preference differ with each installation. If there is not enough bass, for example, then try moving your speakers closer to a wall. The opposite, if there is too much bass. Also see the information on page 11 referring to Port Bungs. If you are losing stereo imaging, try 'toeing' them in slightly. The sound should appear to originate from the centre point between the speakers, not the actual speakers themselves.

Setting up the Silver FX



NOTE: When using 2 pairs of Silver FX's in a 7.1 system, you need to use the Right speaker for the rear surround left and the Left speaker for the rear surround right. This is because of the tweeter phasing.

The Silver FX's are paired, but specifically, right hand and left hand units. Of which both can be configured to bi-pole (normal operation) or di-pole modes. The factory setting is bi-pole.

In bi-pole mode, all speaker units (mid/bass unit and tweeters) are in phase. This feature is designed for when the FX is set up as a rear/surround speaker in a typical 5.1 channel system, or alternatively in a 7.1 channel system without a second pair of FX's for rear/ surround duties.

In di-pole mode, the rear firing tweeters are out of phase with the other tweeter and mid/bass unit. It is best to implement this configuration when using the two pairs FX's as part of a 7.1 channel system, with the FX's taking up positions on the side and rear walls. Please note that the FX's are left and right handed. This is not an issue when used in bi-pole mode. It is essential that they are positioned correctly if used in a 7.1 channel system. Please refer to the positioning section on page 4.



NOTE: Before changing your FX's from bi-pole mode to di-pole mode, please ensure that the speaker wires are disconnected from your loudspeakers. This helps to protect your amplifier.

Fixing the Silver FX to a wall



CAUTION: You will need to determine where the Silver FX's will be fixed and the structure of the wall. For safety reasons, if you are unsure of your ability to provide a secure and safe fixing, do not attempt to fix these speakers to your wall, please obtain the services of a competent and qualified trades person.



CAUTION: Ensure that there are no water pipes or electricity cables running behind where the wall brackets are going to be secured. Work from secure steps and avoid trailing wires.

We do not supply wall fixing screws and plugs with the FX's. Please use suitable fixings for the type of wall construction the FX's will be fixed to.

To fix your FX's to the wall, we would recommend using the wall fixing template enclosed within the packaging carton

Plinth Fixing

Floor standing models only

The Silver 6, 8 & 10's are supplied with plinths to improve stability and acoustic response. The plinths are secured in place by using the supplied M10 bolts. They are not essential should space be at a premium. If you choose not to use the plinths, fit the spiked feet direct to the cabinet.

Before you fit the plinth ensure the floor area is clear of any hard/sharp objects. To fit the plinth turn the cabinet over so that the bottom is facing upwards. Place the plinth onto the cabinet ensuring it is orientated correctly, lining up the bolt holes in the plinth with the inserts in the cabinet. Using the bolts, secure the plinth to the cabinet. Tighten them up gradually at first and ensure the plinth is fitted securely to the cabinet. Fit the feet to the plinth before turning the loudspeaker back over. (Please read the instructions opposite). The spikes are used to improve sound quality and bass performance

Grilles

All of the Silver Series speakers come with grilles covered in acoustically transparent cloth. The grilles are held invisibly in place by magnets in both the grille and the cabinet (except the FX).

To fit them, firstly ensure they are the correct way up (badge at the bottom) and offer them up to the cabinet. The magnets should then pull it into position.

The FX comes with the grilles factory fitted. If you wish to remove them, carefully prize them away from the cabinet with the tips of your fingers. There are three separate grilles fitted to each cabinet.



CAUTION: Always remove grilles before lifting or moving the speakers.

Spiked Foot

For Carpeted Floors

Floor standing models only

The Silver Series spiked foot incorporates a spike for use on carpeted floors and also, a soft polymer pad for use on wooden or tiled floors.

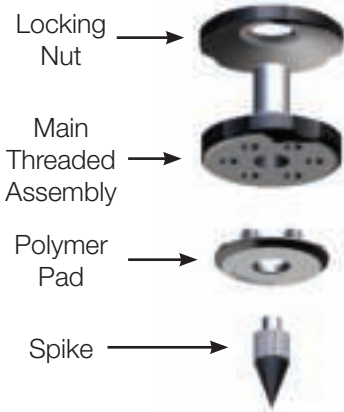

Please ensure there are no hidden wires under the carpet that could be damaged by the spikes.

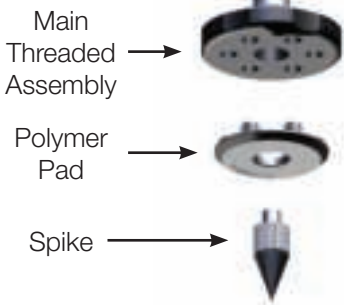

The foot comes fully assembled for use on carpeted floors. All that is required is fixing into the plinth (or cabinet if you chose not to use the plinth). This is achieved by screwing the feet fully into the 4-threaded inserts in the underside of the plinth/cabinet. If your carpet has a very thick pile, remove the soft polymer pad from the foot to ensure the spike goes right through the carpet into the floor. With great care turn your cabinet the right way up. Place the cabinet in your desired location, and

check that it is level on all sides. If it is slightly off level, unscrew the spike at the lowest point and check again. Continue this process until the cabinet is fully level. Use the locking nut on the foot to fix it in place and to stop any unwanted vibrations.

For Wooden/ Hard Floors

Floor standing models only

For use on solid floors or where spikes are inappropriate, it is possible to use the foot without the spike. To use the foot in this manner carefully grip the knurled portion of the spike and rotate anti clockwise and unscrew the spike fully.

You may find it easier to first remove the polymer pad so as to gain more purchase on the spike. The pad should be replaced before carrying out the levelling operation described above.



Connecting Speaker Cables

Bare Wire Connection

Unscrew the binding posts and pass the bare wire through the through-hole and tighten the binding post to clamp the wire in place.



Banana Plugs

Remove the red and black plastic plugs from the terminals and insert the banana plugs into the holes that are revealed. A knife blade of flat blade screwdriver may be required to gain purchase on the plugs.

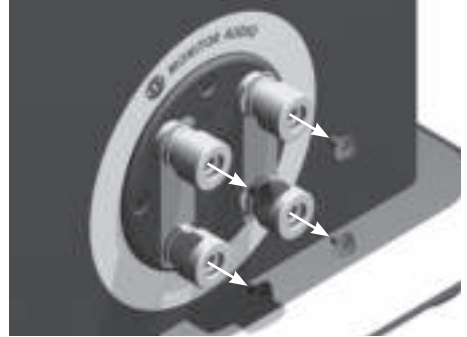

Single Wire

Connect the banana plugs/ bare wire to the terminals. Connect to either the top, bottom or diagonally (experimentation is advisable to achieve the preferred results).



Leave the terminal links in place.



Bi-Wire/ Bi-Amp

Connect the banana plugs/ bare wire to the top and bottom terminals (positive to positive and negative to negative).



The terminal links **MUST** be removed.



Port bungs



WARNING: Care must be taken not to insert the port bungs too far into the port, as this may result in the foam bung being lost inside the cabinet.

If the loudspeaker is to be installed in a small room, typically 9 sqM (80 sqFT), or a room known to reproduce accentuated bass response, it may be desirable to fit port bungs. However, experimentation is recommended with positioning of the loudspeaker in the room prior to fitting. To optimise a loudspeakers performance, ensure it is not positioned too close to a wall or near the corners of a room (refer to the suggestions on pages 4 and 7).

If room aesthetics or layout predetermine speaker positioning, or experiencing the presence of accentuated bass, please move on and read point 1 for the Silver 1 and 2 and point 2 for the Silver 6, 8 and 10.

1. Where bookshelf/ stand-mount speakers (Silver 1 & 2) are to be sited in close proximity of less than 8 inches/ 20cm to a rear wall (such as on a bookshelf, positioned in a cabinet or on a stand close to a wall), we recommend fitting port bungs to the ports. This will reduce the bass 'boom' and assist the loudspeakers to reproduce their best performance under these environmental conditions.
2. Where floor-standing loudspeakers (Silver 6, 8 & 10) are to be sited in close proximity of less than 18 inches/ 45cm to a rear wall, we recommend fitting the port bungs. This will reduce the bass 'boom' and assist the loudspeakers to reproduce their best performance under these environmental conditions.

What is Bass Boom?

Bass 'Boom' (sometimes termed as overhang) is generally caused when bass energy from the loudspeaker 'excites' room modes and causes an accentuation at a particular frequency, or number of frequencies

When fitting port bungs the overall bass extension will not be reduced, however bass energy/ output around the port tuning frequency will be reduced. This has the effect of reducing bass 'boom' while increasing bass clarity and apparent agility.

Experimentation is highly recommended.

Running In

The speakers will require a level of "running in" before they have reached the optimum. The running in process for the Silver Series will be approximately 60 - 70 hours of playback. During the running in process, it is recommended not to push the loudspeakers to high levels as this can cause damage to them. During this time, you will notice the sound open up and become clearer, tighter and a lot more controlled.

MODEL	Silver 1	Silver 2	Silver 6	Silver 8	Silver 10	Silver Centre	Silver FX
System Format	2 - way	2 - way	2 1/2 way	3 - way	3 - way	2 way (M - T - M)	2 - way
Frequency Response	45Hz - 35kHz	40Hz - 35kHz	35Hz - 35kHz	32Hz - 35kHz	30Hz - 35kHz	45Hz - 35kHz	60Hz - 35kHz
Sensitivity (1W@1M)	87dB	88dB	90dB	90dB	90dB	90dB	87dB
Nominal Impedance	8Ohms	8Ohms	8Ohms	4Ohms	4Ohms	8Ohms	8Ohms
Maximum S.P.L	110.8dBA (pair)	112.6dBA (pair)	115.5dBA (pair)	116.8dBA (Pair)	117.8dBA (Pair)	112.5dBA	110.1dBA (pair)
Power Handling (RMS) Watts	100W	120W	150W	200W	250W	150W	85W
Recommended amplifier requirements (RMS)	40 - 100W	40 - 120W	60 - 150W	80 - 200W	80 - 200W	60-150W	40-85W
Bass Alignment	Bass Reflex, Hive® port system	Bass Reflex, Hive port system	Dual Chamber Bass Reflex with Differential Tuning, Twin Hive port system	Bass Reflex, Twin Hive port system	Bass Reflex, Twin Hive port system	Sealed Cabinet	Sealed cabinet
Crossover Frequency	3.0 KHz	2.0KHz	L.F: 700Hz M.F/H.F: 2.7KHz	L.F/M.F: 500Hz M.F/H.F: 2.7KHz	L.F/M.F: 550Hz M.F/H.F: 2.7KHz	2.6KHz	2.2KHz
Drive unit Complement	1 x 6" RST® bass/mid driver 1 x 1" (25 mm) gold dome C-CAM® tweeter	1 x 8" RST bass/mid driver 1 x 1" (25 mm) gold dome C-CAM® tweeter	1 x 6" RST bass driver 1 x 6" RST bass/mid driver 1 x 1" (25 mm) gold dome C-CAM® tweeter	2 x 6" RST bass driver 1 x 4" RST mid-range driver 1 x 1" (25 mm) gold dome C-CAM® tweeter	2 x 8" RST bass driver 1 x 4" RST mid-range driver 1 x 1" (25 mm) gold dome C-CAM® tweeter	2 x 6" RST bass/mid driver 1 x 1" (25 mm) gold dome C-CAM® tweeter	1 x 6" RST bass/mid driver 1 x 1" (25 mm) gold dome C-CAM® tweeter
Cabinet dimensions (Excluding grille, terminals & plinth) (H x W x D)	312 x 185 x 240mm 12 5/16 x 7 5/16 x 9 7/16 Inch	375 x 230 x 300mm 14 3/4 x 9 1/8 x 11 13/16 Inch	885 x 185 x 240mm 34 13/16 x 7 5/16 x 9 7/16 Inch	1000 x 185 x 300mm 39 3/8 x 7 5/16 x 11 13/16 Inch	1050 x 230 x 300mm 41 5/16 x 9 1/16 x 11 13/16 Inch	185 x 500 x 200mm 7 5/16 x 19 11/16 x 7 7/8 Inch	250 x 311 x 130mm 9 13/16 x 12 1/4 x 5 1/8 Inch
External dimensions (Including terminals) (H x W x D)	312 x 185 x 263mm 12 5/16 x 7 5/16 x 10 3/8 Inch	375 x 230 x 323mm 14 3/4 x 9 1/8 x 12 11/16 Inch	885 x 185 x 263mm 34 13/16 x 7 5/16 x 10 3/8 Inch	1000 x 185 x 323mm 39 3/8 x 7 5/16 x 12 11/16 Inch	1050 x 230 x 323mm 41 5/16 x 9 1/16 x 12 11/16 Inch	185 x 500 x 223mm 7 5/16 x 19 11/16 x 8 5/8 Inch	250 x 311 x 130mm 9 13/16 x 12 1/4 x 5 1/8 Inch
External dimensions (Including grille & terminals) (H x W x D)	312 x 185 x 275mm 12 5/16 x 7 5/16 x 10 3/8 Inch	375 x 230 x 339mm 14 3/4 x 9 1/8 x 13 9/16 Inch	885 x 185 x 275mm 34 13/16 x 7 5/16 x 10 3/8 Inch	1000 x 185 x 339mm 39 3/8 x 7 5/16 x 13 9/16 Inch	1050 x 230 x 339mm 41 5/16 x 9 1/16 x 13 9/16 Inch	185 x 500 x 235mm 7 5/16 x 19 11/16 x 9 1/4 Inch	250 x 311 x 143mm 9 13/16 x 12 1/4 x 5 5/8 Inch
External dimensions (Including plinth & feet) (H x W x D)	N/A	N/A	986 x 245 x 300mm 36 7/8 x 9 5/8 x 11 13/16 Inch	1021 x 245 x 360mm 40 3/16 x 9 5/8 x 14 3/16 Inch	1071 x 290 x 360mm 42 3/16 x 11 7/8 x 14 3/16 Inch	N/A	N/A
Weight (each)	6.95kg (15lb 4oz)	9.7kg (21lb 6oz)	16.5kg (40lb 8oz)	23.53kg (51lb 6oz)	26.03kg (57lb 4oz)	9.6kg (21lb 2oz)	5.1kg (11lb 4oz)



Monitor Audio Ltd.
24 Brook Road
Rayleigh, Essex
SS6 7XJ
England
Tel: +44 (0)1268 740580
Fax: +44 (0)1268 740589
Email: info@monitoraudio.co.uk

monitoraudio.com

Designed and Engineered in the
United Kingdom, made in China

© 2013. Version 1