

Heavy-duty Circulation Pump

A magnetic drive seal-less pump with 20 or 38 mm ports, designed for a maximum flow of 65 or 115 litres

The CM90 circulation pump has been developed primarily for heating and cooling applications in buses, trains and boats, but it is much more. In closed systems or wherever else self-priming is not required, the CM90 is an all-round pump that distinguishes itself for its dependability, capacity and long service life.

The CM90 pump has a magnetic drive, which means that no shaft seal is necessary, as the motor shaft does not penetrate the pump house. With no mechanical seal, longer service life is assured.

Heat flanges on both the motor and the pump also increase service life as they dissipate heat from the unit, which can pump liquids efficiently at a very wide range of temperatures. The CM90 also features integral thermal overload protection and is EMC approved according to EN 55014 standards.

The CM90 magnetic driven centrifugal pump combines a high flow rate with very low electricity consumption, making it ideal for vehicular heating and cooling systems.



Features & Benefits

- Maximum flow of 65 or 115 litres per minute @ 0.1 bar (17.2 or 30 GPM @ 1.45 psi)
- Designed for liquid temperatures of -40°C to +100°C (-40°F to +212°F)
- Ambient operational temperature range: -40°C to +90°C (-40°F till +194°F)
- Seal-less magnetic drive
- Specifically engineered for continuous operation
- Extended service life
- Ball bearing brush motor - Enclosure IP67
- Equipped with heat flanges for improved cooling
- Steel motor housing
- 12V or 24V motors
- Thermal overload protection
- Universal mounting bracket
- Industry standard ports
- Complies with Recreational Craft Directive 94/25/EEC: (ISO 8846), (ISO 10133)
- Complies with Electromagnetic Compatibility Directive 2004/108/EC: (EN55014-1: 2006), (EN55014-2: 1997 +A1: 2001), (EN61000-6-3: 2007 + A1: 2011)

CM90 – Electrically powered, centrifugal pump with magnetic transmission

The CM90 has been designed to circulate water or a water/antifreeze mixture in the heating systems of buses, trains and boats.

Technical specifications:

- Capacity:
 20 mm (3/4") port 65 l/min (17.2 GPM) at 0.1 bar
 38 mm (1 1/2") port 115 l/min (30.4 GPM) at 0.1 bar
- System pressure: -0.2 to +2.5 bar; stationary max. 4.0 bar
- Liquid: Water/glycol mixture; max. 60% glycol
- Motor service life: 10,000 hours at nominal voltage (and 30°C ambient temperature)
 10,000 start/stops. Interchangeable motor.
- Motor, voltage: Nominal 13.6V DC for use between 10-16V
 Nominal 27.2V DC for use between 20-32V
- Input power: Max. 125W
- Dry running: 30 minutes
- Ports: 20 mm (3/4") or 38 mm (1 1/2") diameter
- Weight: 3.0 kg (6.6 pounds)
- Body: PPA, fiberglass reinforced
- Mounting: Separate universal bracket for flat surfaces
- Directives:
 Recreational Craft Directive 94/25/EEC
 (ISO 8846), (ISO 10133)
 Electromagnetic Compatibility Directive 2004/108/EC
 (EN55014-1: 2006), (EN55014-2: 1997 +A1: 2001), (EN61000-6-3: 2007 + A1: 2011)

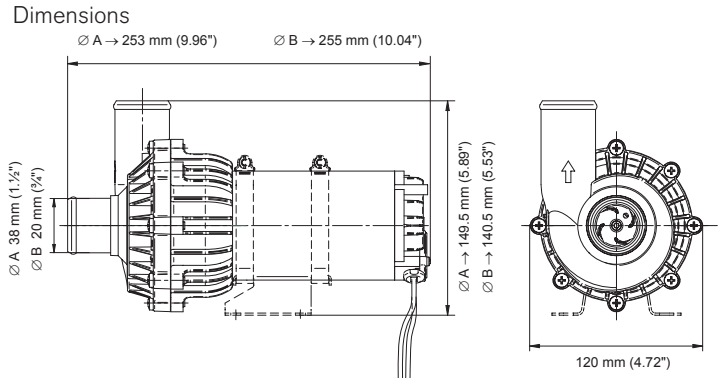

Pressure and capacity data

Based on water at 20°C/68°F (and recommended hose)

HOSE CONNECTION	BACK PRESSURE			FLOW		AMPERAGE	
	BAR	kPA	FT	L/MIN	USGPM	13.6V	27.2V
Ø 38 mm (1.1/2")	0.1	10	3.4	115	30.4	10	4.6
	0.25	25	8.4	85	22.5	9.5	4.5
	0.4	40	13.4	40	10.6	9	4.2
Ø 20 mm (3/4")	0.1	10	3.4	65	17.2	8.5	4
	0.25	25	8.4	50	13.2	8	3.8
	0.4	40	13.4	30	7.9	7.5	3.6
FUSE REQUIRED						12	6

DESCRIPTION	ORDER NO	WITH UNIVERSAL BRACKET
CM90P7-1 13.6V DIA 38		10-24664-09
CM90P7-1 27.2V DIA 38		10-24664-10
CM90P7-1 13.6V DIA 20		10-24750-09
CM90P7-1 27.2V DIA 20		10-24750-10



Customer Service & Support
 Johnson Pump Marine

SE +46 19 21 83 10 johnson-pump.marine@spxflow.com
 US +1 847 671-7867 jp-customerservice@spxflow.com
 AUS +61 03 9589 9222 ft.aus.cs@spxflow.com

For more information about our worldwide locations, approvals, certifications, and local representatives, please visit www.spxflow.com.

SPX FLOW, Inc. reserves the right to incorporate our latest design and material changes without notice or obligation. Design features, materials of construction and dimensional data, as described in this bulletin, are provided for your information only and should not be relied upon unless confirmed in writing.