

KETER[®]

EXCELLENCE XL -MULTIPURPOSE WITH CLOTH HANGER”

EN ASSEMBLY INSTRUCTIONS DE INSTRUCTIONS DE MONTAGE DE MONTAGEANLEITUNG DE MONTAGEVOORSCHRIFT
ES INSTRUCCIONES DE MONTAJE IT ISTRUZIONI DI MONTAGGIO PT INSTRUÇÕES DE MONTAGEM EL ΟΔΗΓΙΕΣ
ΣΥΝΑΡΜΟΛΟΓΗΣΗΣ PL INSTRUKCJA MONTAŻU 装配说明 HU ÖSSZESZERELÉSI ÚTMUTATÓ HR UPUTE ZA MONTAŽU
RO INSTRUȚIUNI DE ASAMBLARE SI NAVODILA ZA MONTAŽO RU ИНСТРУКЦИЯ ЗА МОНТАЖ RU ИНСТРУКЦИЯ
ПО МОНТАЖУ UK ІНСТРУКЦІЯ З МОНТАЖУ CZ NÁVOD K MONTÁŽI SK MONTÁŽNE POKYNY LT MONTAVIMO INSTRUKCIJA
LV UZSTĀDĪŠANAS INSTRUKCIJA ET PAIGALDAMISE JUHEND

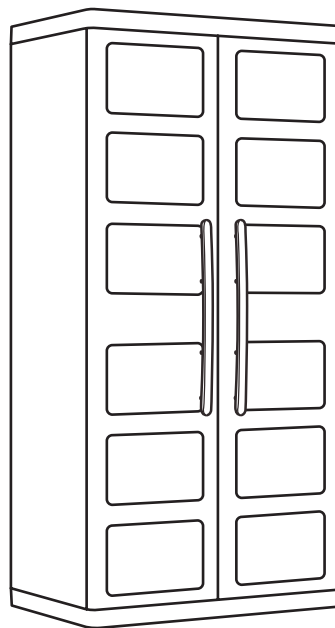

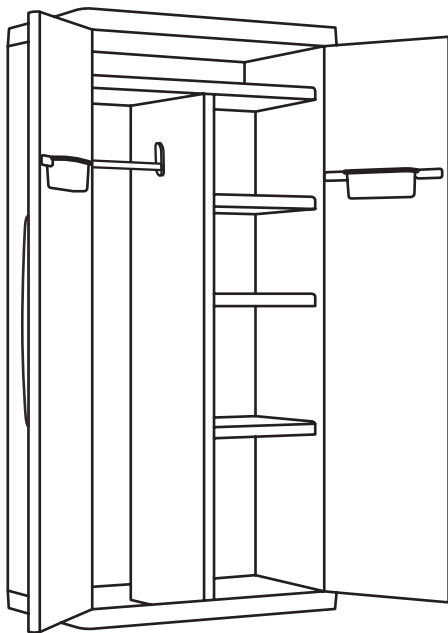







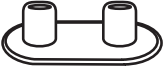

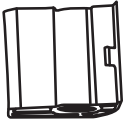
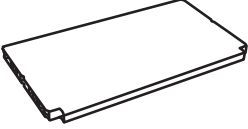
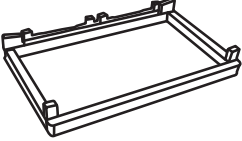
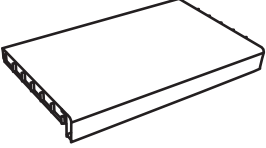

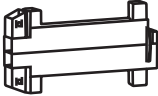

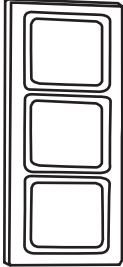
290025_Rev.00_12/20

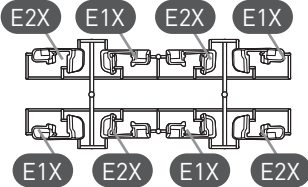

Keter Italia
Via Ing. Taliercio 2, 31024 Ormelle TV
Tel: +39 0422 745900, Fax +39 0422 745929

WWW.KETER

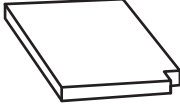
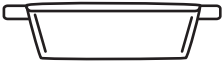
<p>4x P</p> 	<p>4x TT</p> 	<p>4x XCS</p> 	<p>4x XCD</p> 
<p>1x XRA</p> 	<p>2x XBT</p> 	<p>4x XPL</p> 	
<p>2x XGD</p> 	<p>2x XGB</p> 	<p>2x XGPL</p> 	
<p>4x XB</p> 	<p>4x XD</p> 	<p>2x XPIP</p> 	<p>2x TM</p>  <p>2x BM</p> 
<p>2x XCDD</p> 	<p>2x XCDS</p> 	<p>2x</p> 	
<p>8x [4,5x20 mm]</p> 	<p>3x XRP</p> 	<p>2x XV</p> 	



IT Conservare il manuale d'uso per referenze future in prossimità del prodotto. Prima di iniziare l'assemblaggio leggere attentamente le avvertenze. **EN** Keep this instruction manual with the product for future reference. Read the instructions carefully before assembly. **DE** Bewahren Sie das Benutzerhandbuch in der Nähe des Produkts auf, damit Sie später jederzeit nachschlagen können. Lesen Sie vor der Montage die Anweisungen aufmerksam durch. **FR** Conserver le manuel d'utilisation à proximité du produit pour de futures références. Lire attentivement la notice avant de commencer l'assemblage. **ES** Guarde el manual de uso para futuras consultas cerca del producto. Antes de empezar el montaje, lea detenidamente las advertencias. **NL** Bewaar de handleiding in nabijheid van het product voor toekomstige raadpleging. Lees deze voorschriften aandachtig alvorens met de montage te beginnen. **TR** Kullanıcı el kitabını ürünün yakınına saklayın. Montajı başlatmadan önce etiketleri dikkatle okuyun. **EL** Φυλάξτε αυτό το εγχειρίδιο χρήσης κοντά στο προϊόν για μελλοντικές χρήσεις. Πριν ξεκινήσετε την συναρμολόγηση διαβάστε προσεκτικά τις προειδοποιήσεις ασφαλείας. **RU** Храните руководство пользователя поблизости от изделия для дальнейшего к нему обращения. Перед тем, как приступить к сборке, внимательно ознакомьтесь с предупреждениями. **RO** Păstrați manualul de utilizare în apropierea produsului pentru consultări ulterioare. Înainte de a începe asamblarea citiți cu atenție avertismentele. **CZ** Uchovejte tento návod pro jeho případné další použití. Před montáží si pečlivě přečtete instrukce. **PL** Przechowywać instrukcję obsługi w pobliżu produktu do przyszłych konsultacji. Przed rozpoczęciem montażu przeczytać uważnie pouczenia. **PT** Guarde o manual de uso para consultas futuras na proximidade do produto. Antes de iniciar a montagem, leia os avisos com atenção.

01

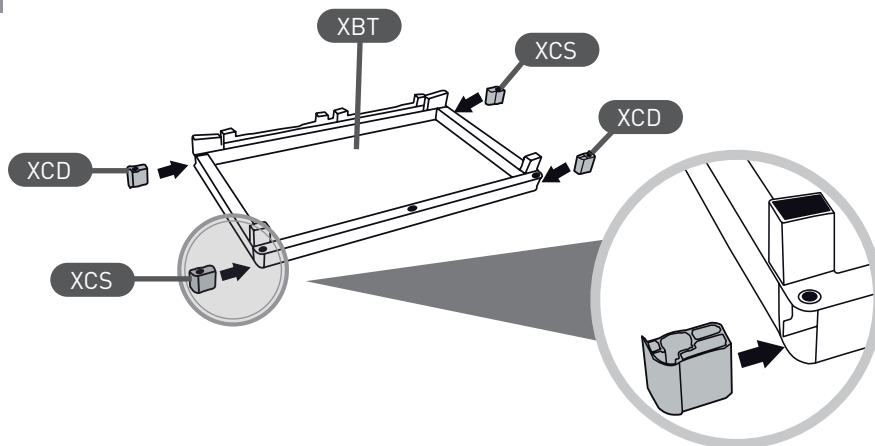

02

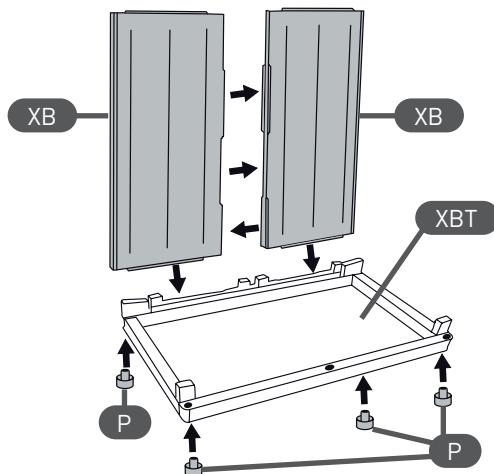

03

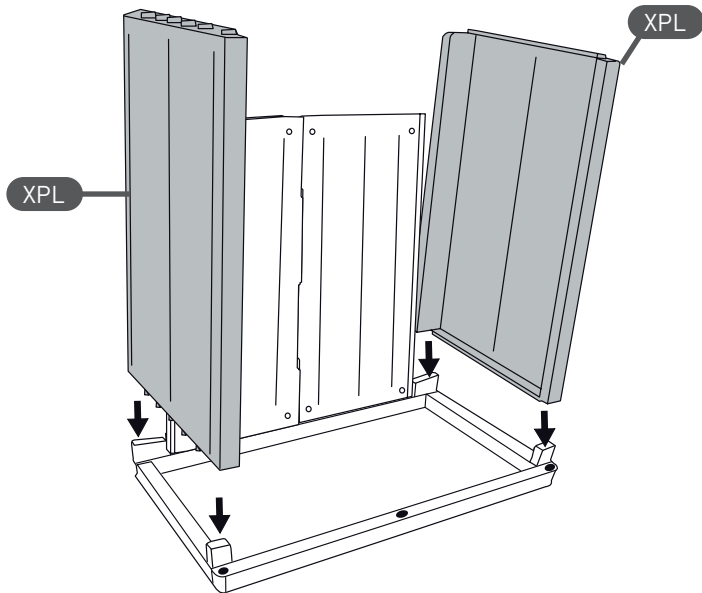

04

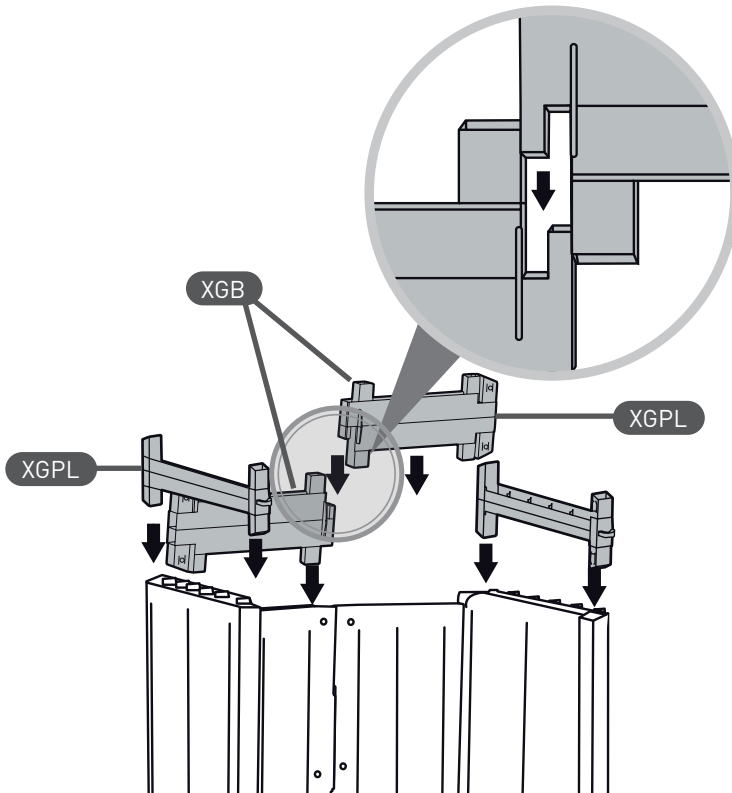

05

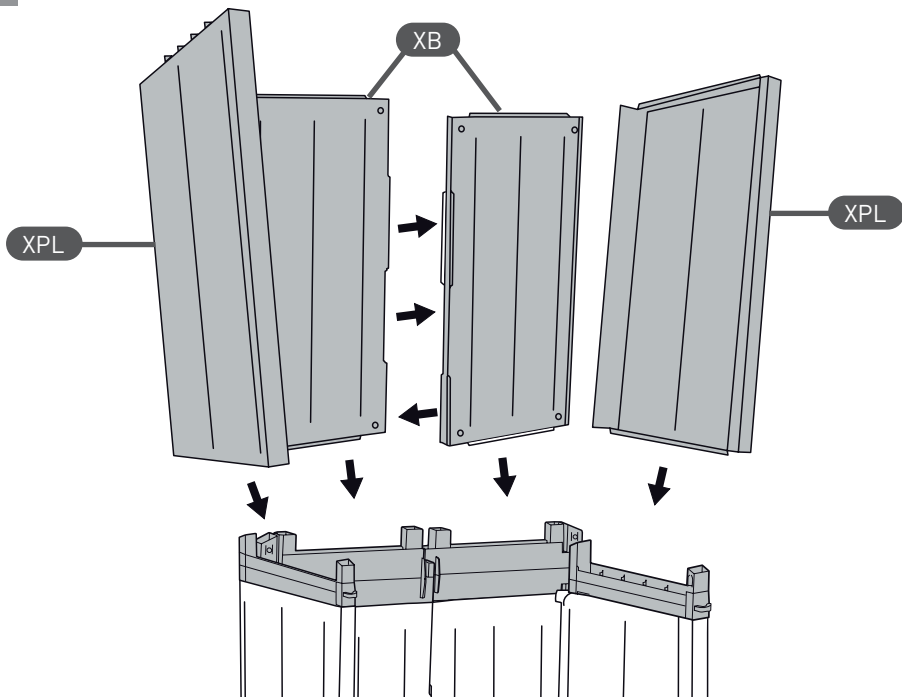

06

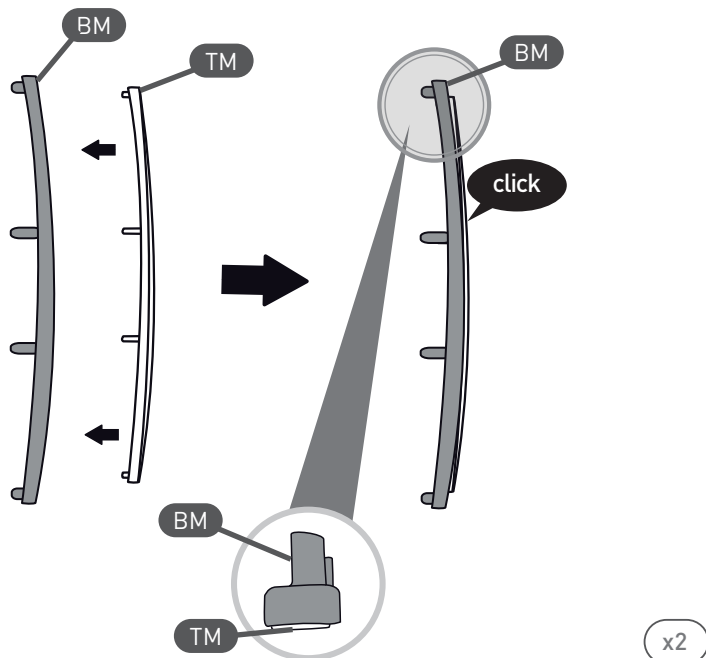

07

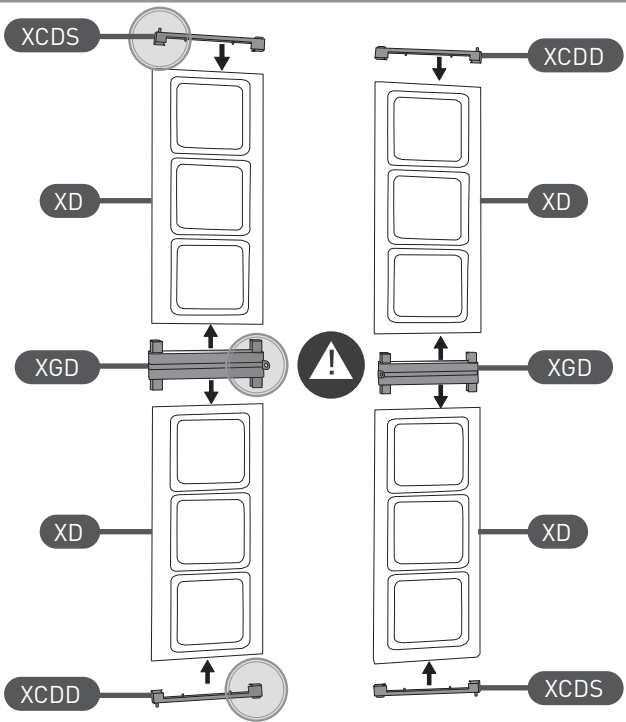

08

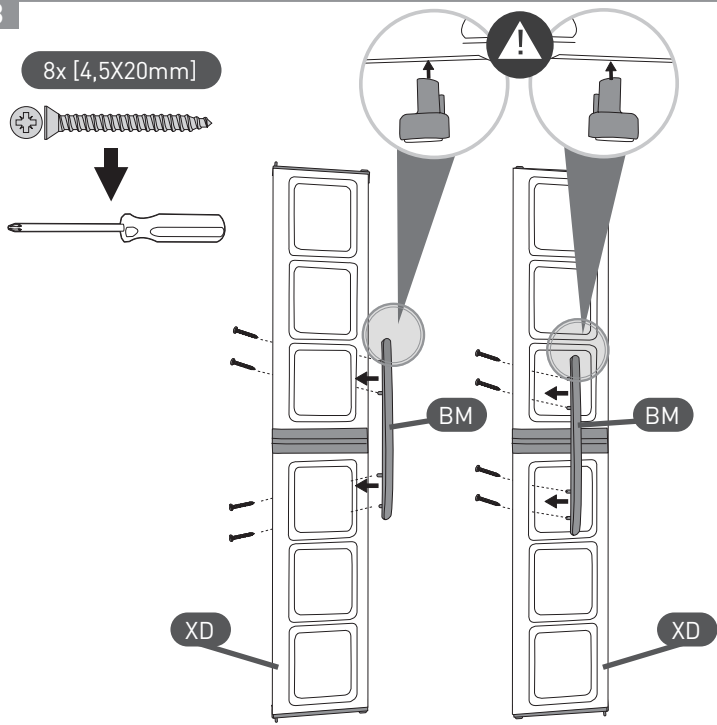

09

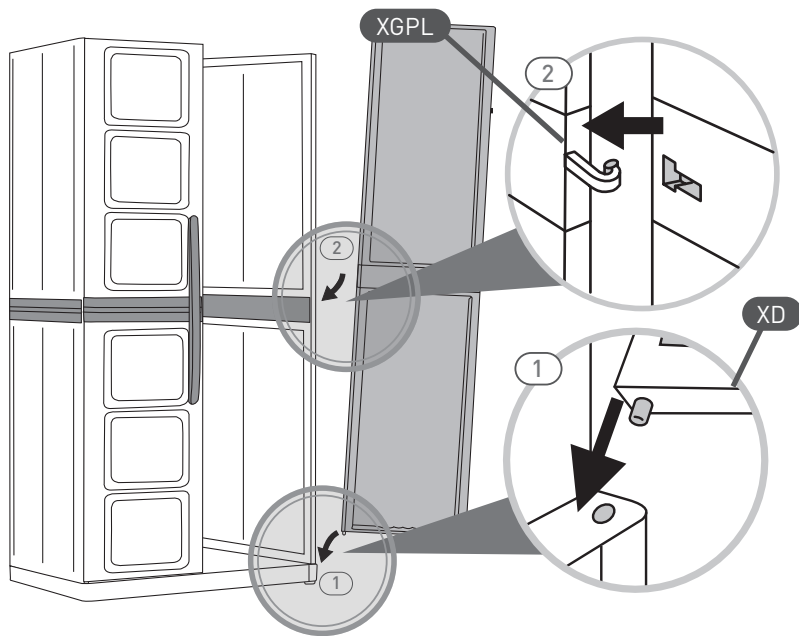

10

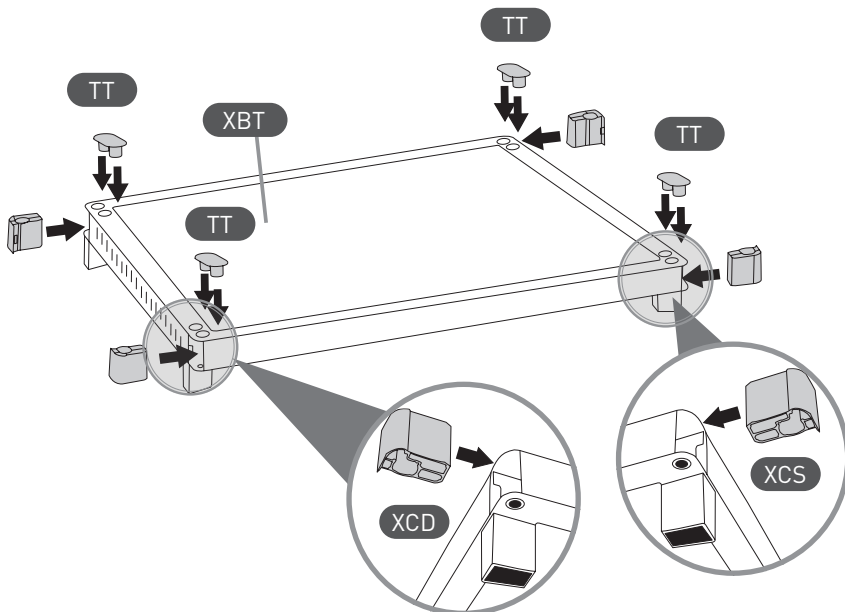

11

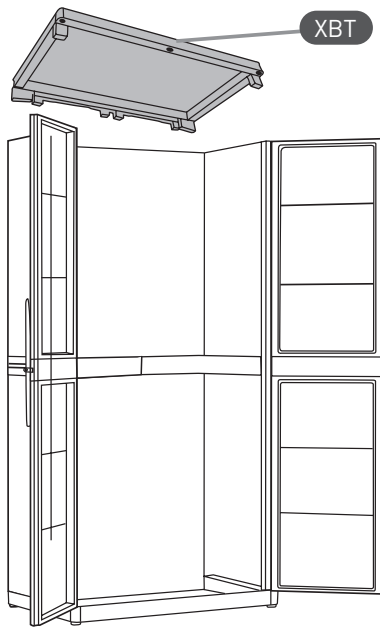

12

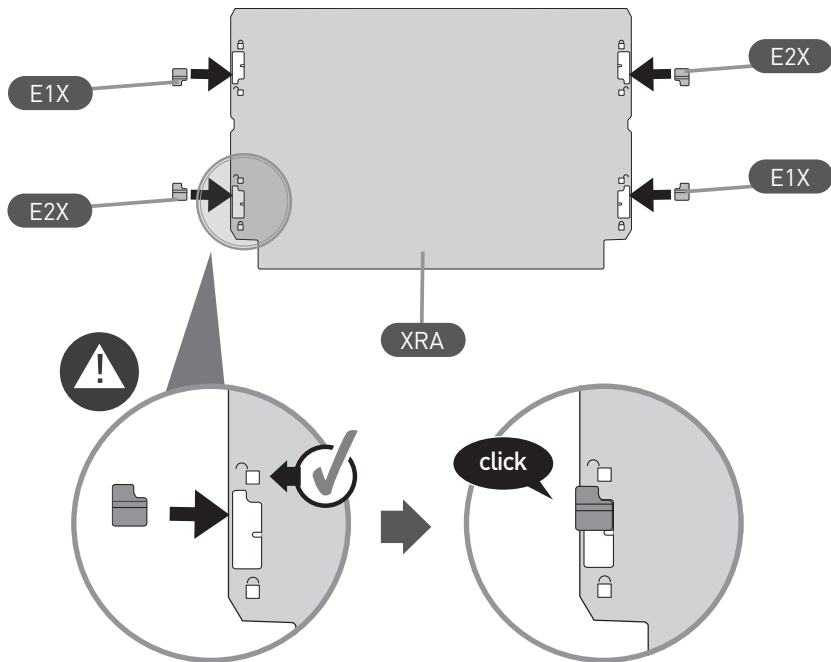

13

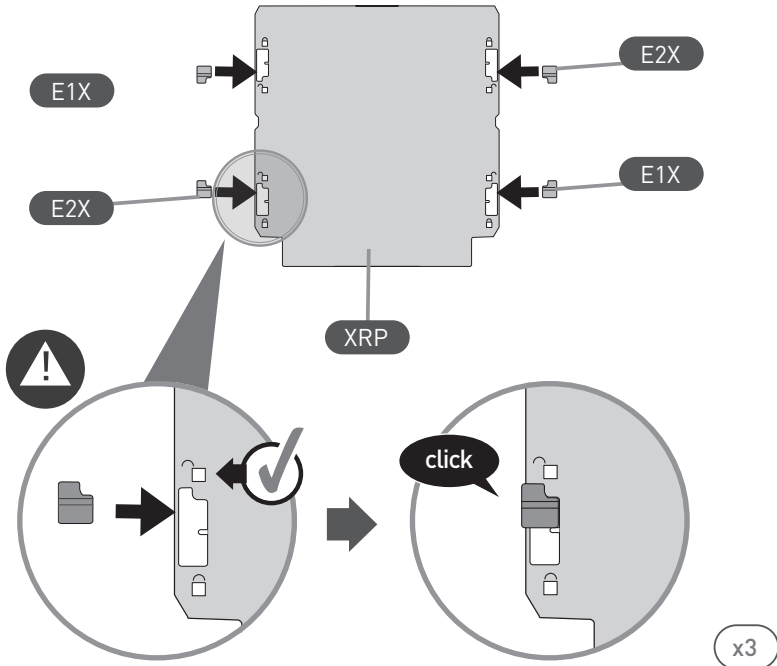

14

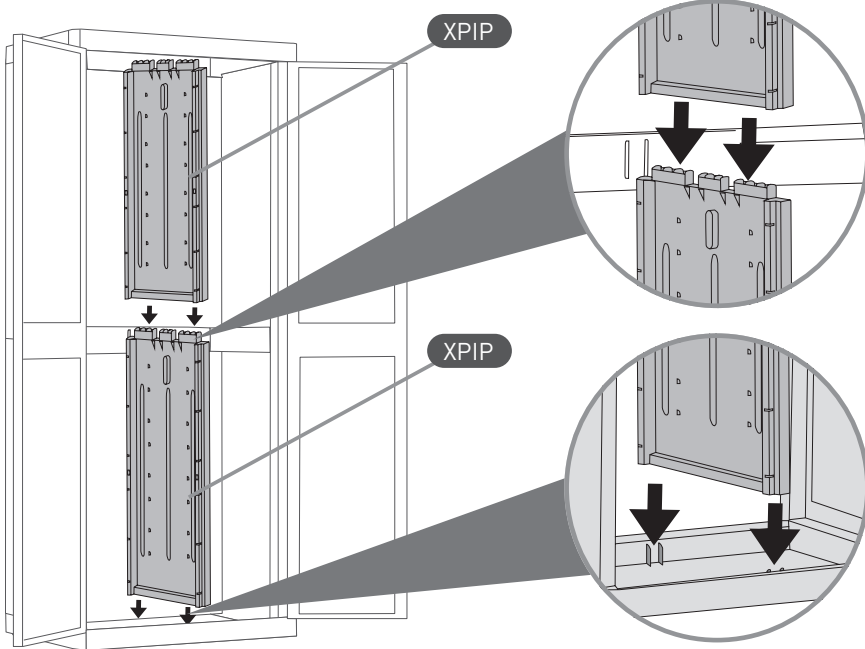

15

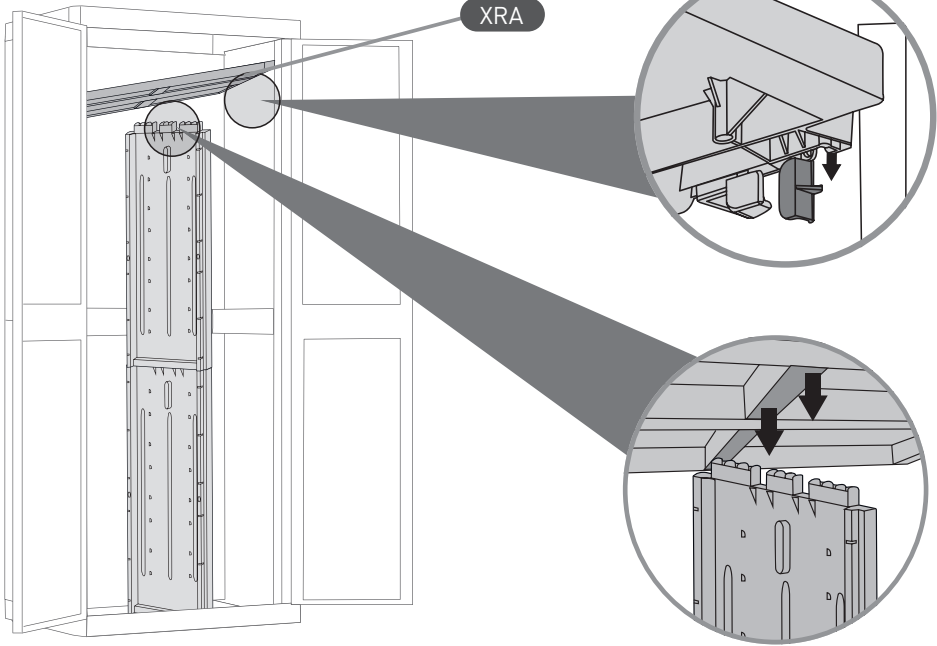

16

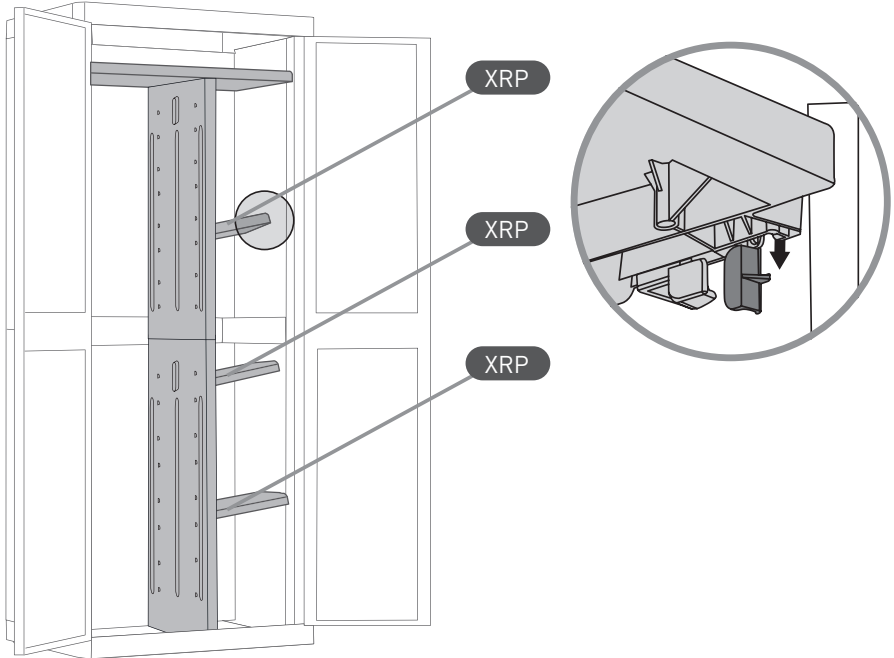

17

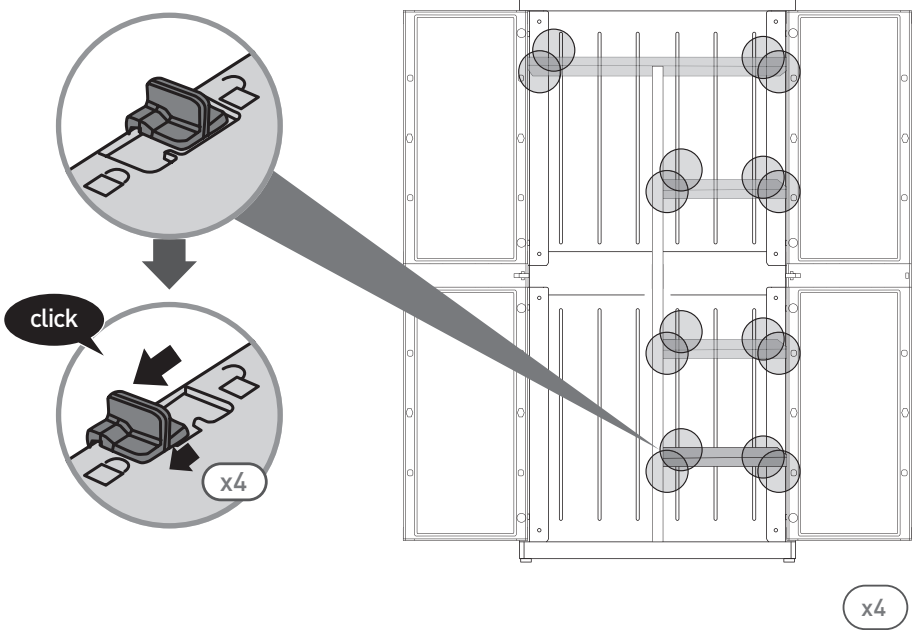

18

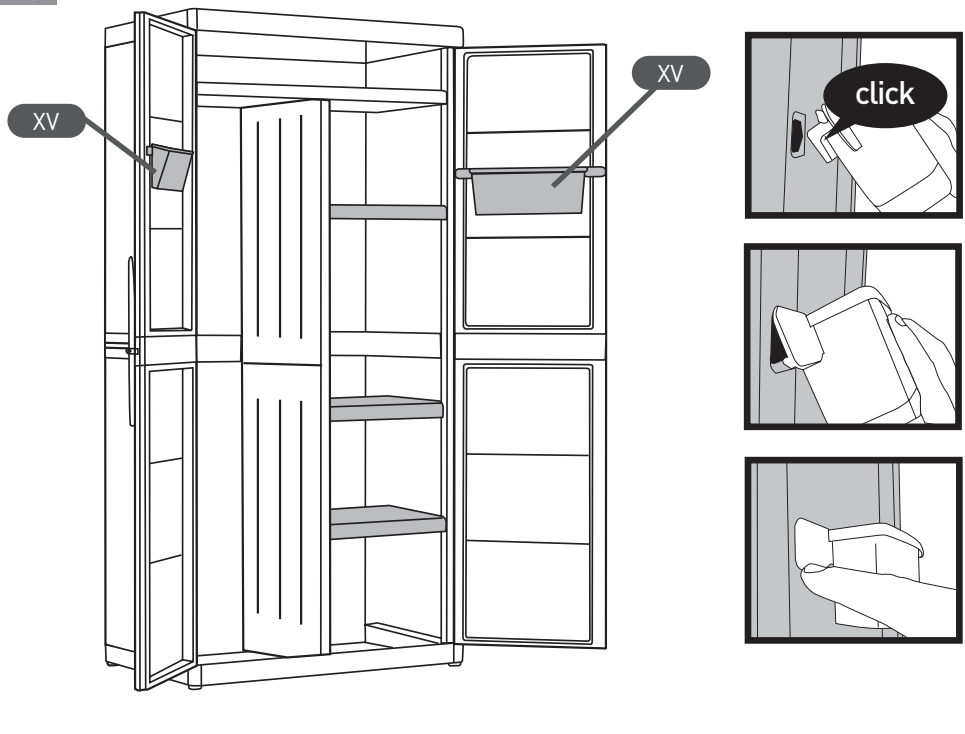

17 Fissare l'armadio a muro (viti e tasselli non inclusi). Scegliere il tassello in base alla superficie di appoggio. **18** Fasten the cupboard to the wall (screws and anchors not included). Choose the anchor according to the surface. **19** Befestigen Sie den Schrank an der Wand (Schrauben und Dübel sind nicht im Lieferumfang enthalten). Den Dübel je nach Stellfläche wählen. **20** Fixer l'armoire au mur (vis et chevilles non incluses). Choisir la cheville en fonction de la surface d'appui. **21** Fije el armario en la pared (la dotación no incluye tornillos y tacos). Elija el taco en función de la superficie de apoyo. **22** Bevestig de kast aan de muur (schroeven en pluggen niet bijgeleverd). Kies de plug aan de hand van het steunoppervlak. **23** Dolabı duvara sabitleyin (vidalar ve dübeller dahil değil). Destek yüzeyine göre dübel seçin. **24** Στερεώστε την ντουλάπα στον τοίχο (βίδες και ούπα δεν περιλαμβάνονται). Επιλέξτε το ούπα ανάλογα με την επιφάνεια στήριξης. **25** Закрепите шкаф на стене (шурупы и дюбели не включены в поставку). Возьмите дюбель, пригодный для материала поверхности, у которой ставится шкаф. **26** Fixați dulapul la perete (șuruburi și dibluri neincluse în dotare). Alegeți diblul în funcție de suprafața pe care urmează să se fixeze. **27** Připevněte skříň ke zdi (šrouby a hmoždinky nejsou součástí dodávky). Zvolte hmoždinku podle povrchu podkladu. **28** Przymocować szafę do muru (śruby i kotki nie są zawarte w dostawie). Dobrac kotek w zależności od powierzchni oparcia. **29** Fixe o armário na parede (parafusos e buchas não incluídos). Escolher a bucha conforme a superfície de apoio.

