

HOW TO DEFINE YOUR FLAG HALYARD LENGTH

– At the (aft) lower diagonal schroud, set the **positioning hitch** to center your halyard (without flag) between the mast and the cap shroud (see picture). This way you prevent the flag from continually hitting the shroud or mast and wearing it out, plus making an annoying sound when you are below.

– Set the **Button cleat** not higher than 20 cm. below the **hitch**.

– Finally adjust your halyard length to make it fit around the **Button cleat**.

No matter how many flags you fly, the adjustable **button shroud cleat** adapts easily to the varying length of your halyard.

Use 3-4 mm. halyard rope. Preferably 3 mm (1/8") braided polyester.
Maintenance: Rinse with fresh water.

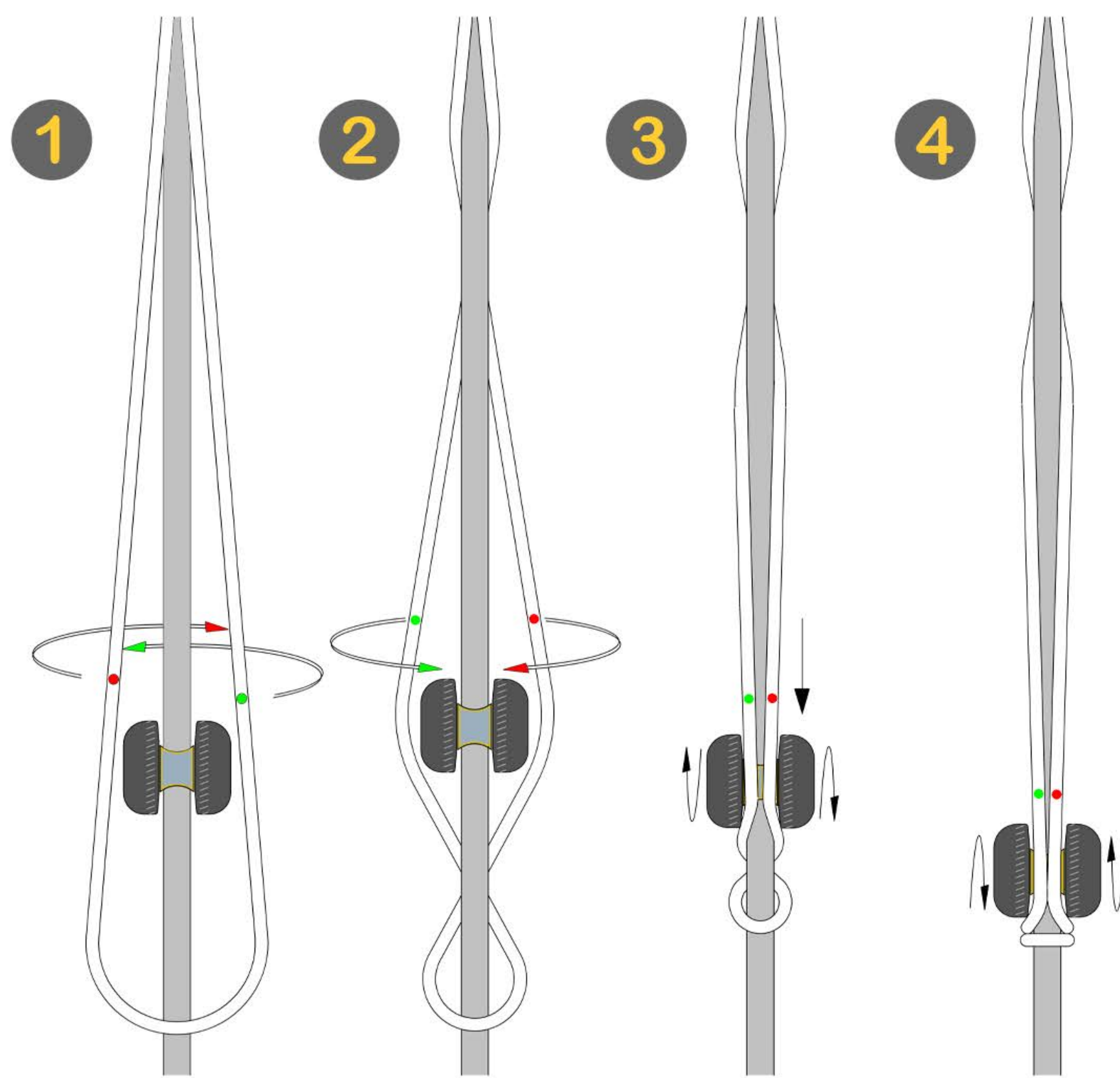
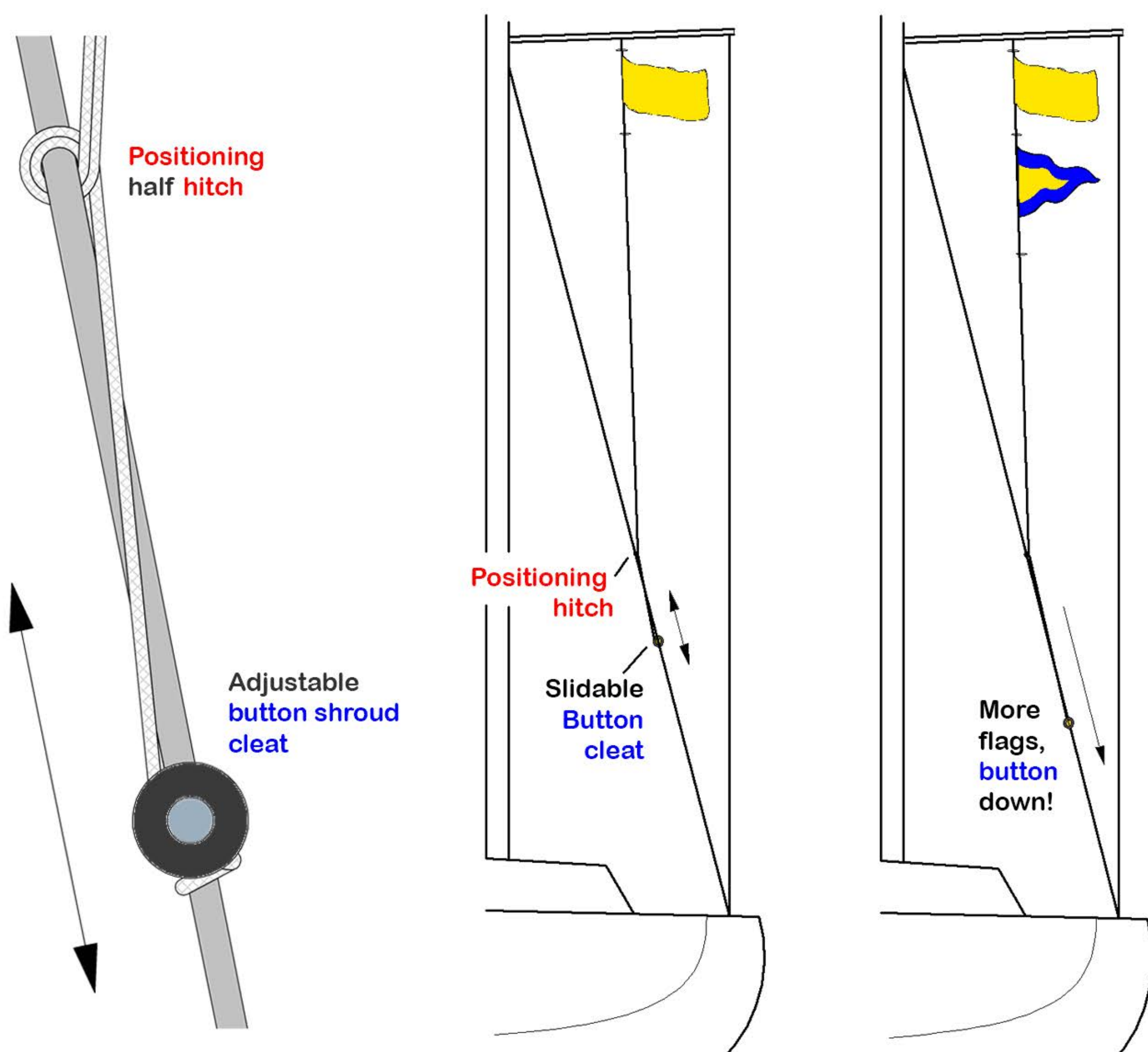

- 1 Cross the halyard loop behind the shroud.
- 2 Pull it forward again and lock it in the button groove.
- 3 Unscrew (1/4 turn) the button.
- 4 Slide it down to tighten the halyard and fasten the button again.

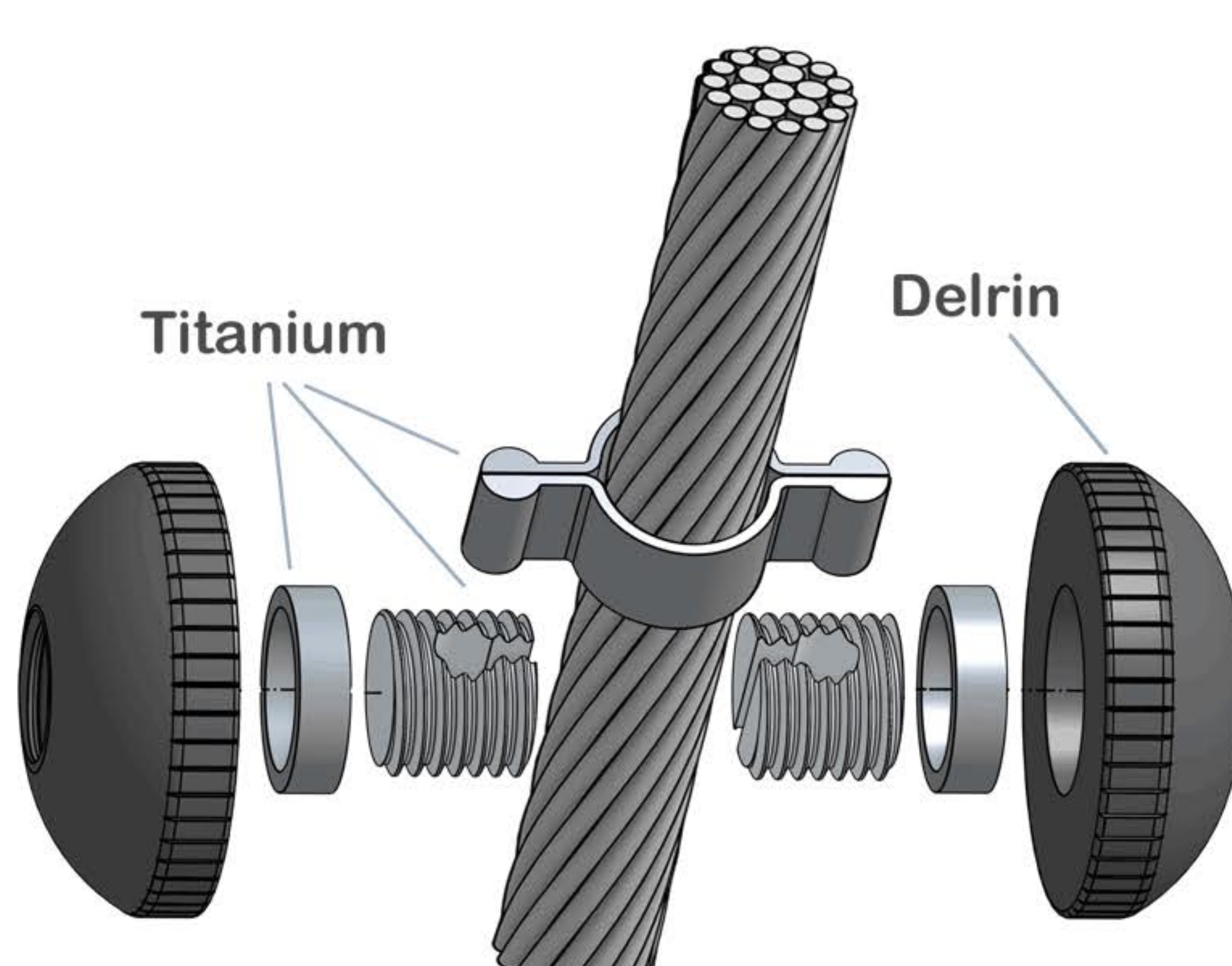
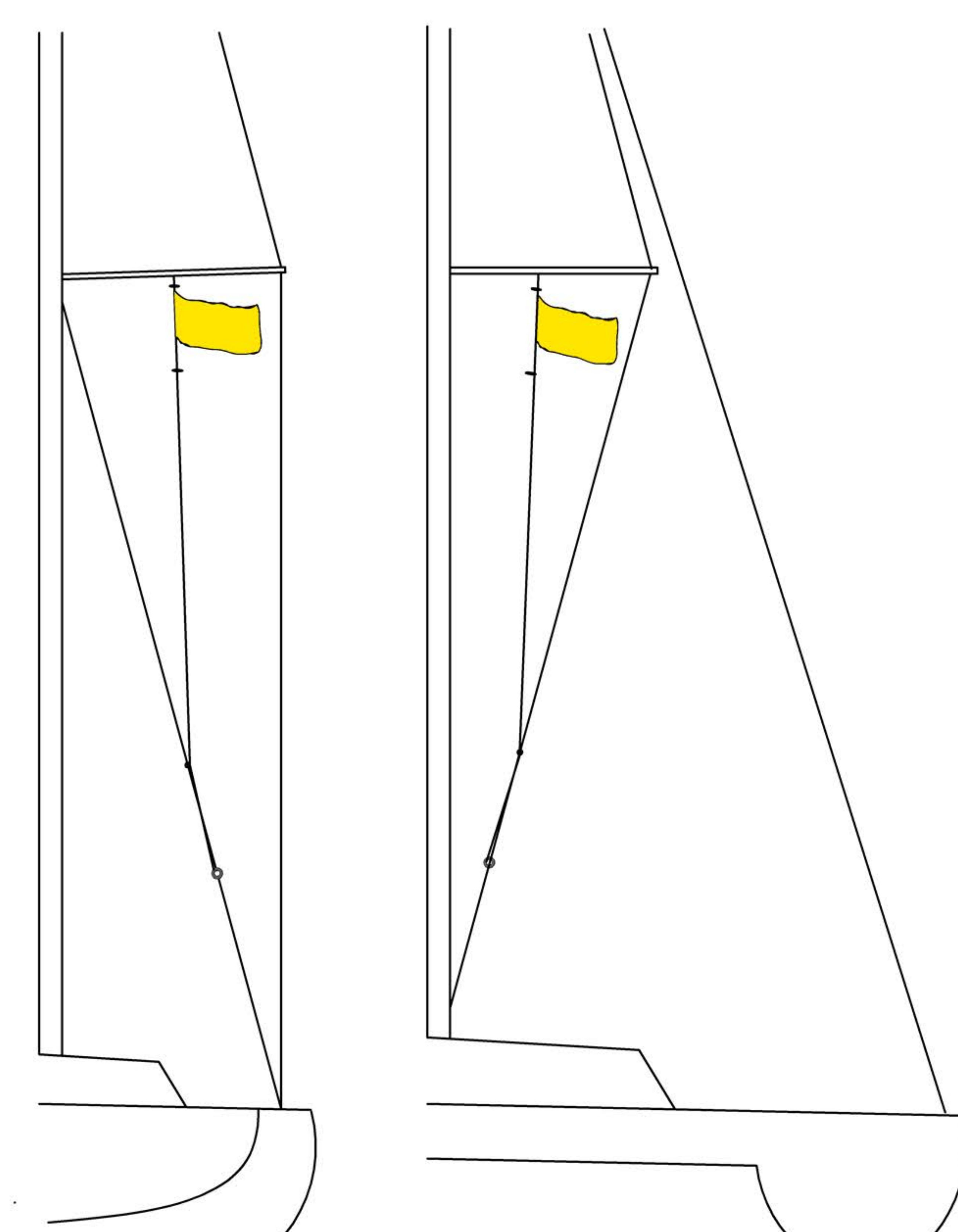

Tips: Practice assembling of the button cleat above a table first.
Place a towel on deck while mounting it to the shroud. This way you reduce the risk that if something accidentally falls, it will bounce on deck and fall into the water.
Take your time, you only have to do it once.