

TOORX
FITNESS IN MOTION

INSTRUCTION



MSX3000



Cod : GRLDTOORXMSX3000

Rev : 00

Ed : 10/18

Table of Contents

Spare parts list	3
Spare parts list	4
Spare parts list	5
Spare parts drawing.....	6
Fasteners drawing.....	7
Assembly step (1)	8-9
Assembly step (2)	10-11
Assembly step (3)	12-13
Assembly step (4)	14-15
Assembly step (5)	16-17
Assembly step (6)	18-19
Assembly step (7)	20-21
Assembly step (8)	22-23
Assembly step (9)	24-26
Assembly step (10)	27-28
Assembly step (11)	29-31
Assembly step (12)	32-33
Assembly step (13)	34-36
Assembly step (14)	37-38
Assembly step (15)	39-40
Assembly step (16)	41-42
Assembly step (17)	43-44
Assembly step (18)	45-46
Factory assembly spare parts list.....	47
Factory assembly steps.....	48-55

Spare parts list

No.	Description	Note	Qty.
1	ground frame		1
2	guide rod	Φ25*1853	2
3	back support rod	Φ259*1757.5	2
4	hexagon bolt	M10*65	6
5	washer	Φ10	78
6	hexagon bolt	M10*20	8
7	spring washer	Φ10	14
8	rubber cushion	Φ60*Φ26*42	2
9	counter weight rubber cushion	Φ60*Φ26*20	2
10	hexagon socket button head bolt	M8*70	2
11	lock nut	M8	6
12	selector rod	92 KG	1
13	counter weight	6 KG	14
14	topmost counter weight	8 KG	1
15	washer	Φ8	26
16	weight pin	Φ10*100	1
17	lock pin		2
18	pull pin	Φ10	2
19	hexagon bolt	M12*70	4
20	washer	Φ12	23
21	lock nut	M12	11
22	front frame		1
23	lock nut	M10	32
24	shield support frame		1
25	upper frame		1
26	hexagon bolt	M12*130	3
27	right cover		1
28	left cover		1
29	hexagon bolt	M12*75	4
30	hexagon bolt	M10*25	2
31	axis of rotation	Φ17*57	1
32	seat cushion adjust frame		1
33	seat cushion tube		1

Spare parts list

No.	Description	Note	Qty.
34	leg curl elbow tube		1
35	big washer	Φ25*10*2.0	6
36	hexagon bolt	M8*16	9
37	pull pin	Φ12	1
38	shaft	Φ17*134	1
39	shaft	Φ17*100	1
40	front push holder		1
41	guard plate		1
42	front push arm		1
43	hexagon bolt	M10*70	1
44	hexagon socket button head bolt	M10*16	2
45	right butterfly arm		1
46	left butterfly arm		1
47	pulley support frame		1
48	reinforcing plate		1
49	footplate		1
50	hexagon bolt	M10*130	6
51	hexagon bolt	M10*115	2
52	hexagon bolt	M10*45	19
53	hexagon socket button head bolt	M10*45	1
54	"-" shape pulley frame		2
55	pulley	Φ95*26	27
56	connecting sleeve	Φ14*100	1
57	pulley spacer	Φ22*Φ10.5*45.5	4
58	lat pull cable	L:4540mm	1
59	cable hook		1
60	9 link chain & snap hook		5
61	double pulley plate		1
62	middle cable	L:1500mm	1
63	hexagon bolt	M8*45	4
64	butterfly arm cable	L:5375mm	1
65	hexagon bolt	M10*75	2
66	hexagon bolt	M10*85	1

Spare parts list

No.	Description	Note	Qty.
67	powder metallurgy sleeve	Φ10	2
68	left support plate		1
69	right support plate		1
70	low pull cable	L=3365mm	1
71	short bar		1
72	spring washer	Φ8	12
73	hexagon bolt	M8x40	4
74	back cushion adjustment frame		1
75	back cushion		1
76	seat cushion		1
77	hexagon socket button head bolt	M8x25	6
78	sponge inner cap		6
79	sponge outer cap		6
80	sponge	Φ10x75	6
81	sponge rod	Φ25x480	1
82	sponge rod	Φ25x450	1
83	shield		2
84	long bar		1
85	handle belt		2
150	hexagon bolt	M8x25	1
162	hexagon bolt	M10x40	2

Spare parts drawing

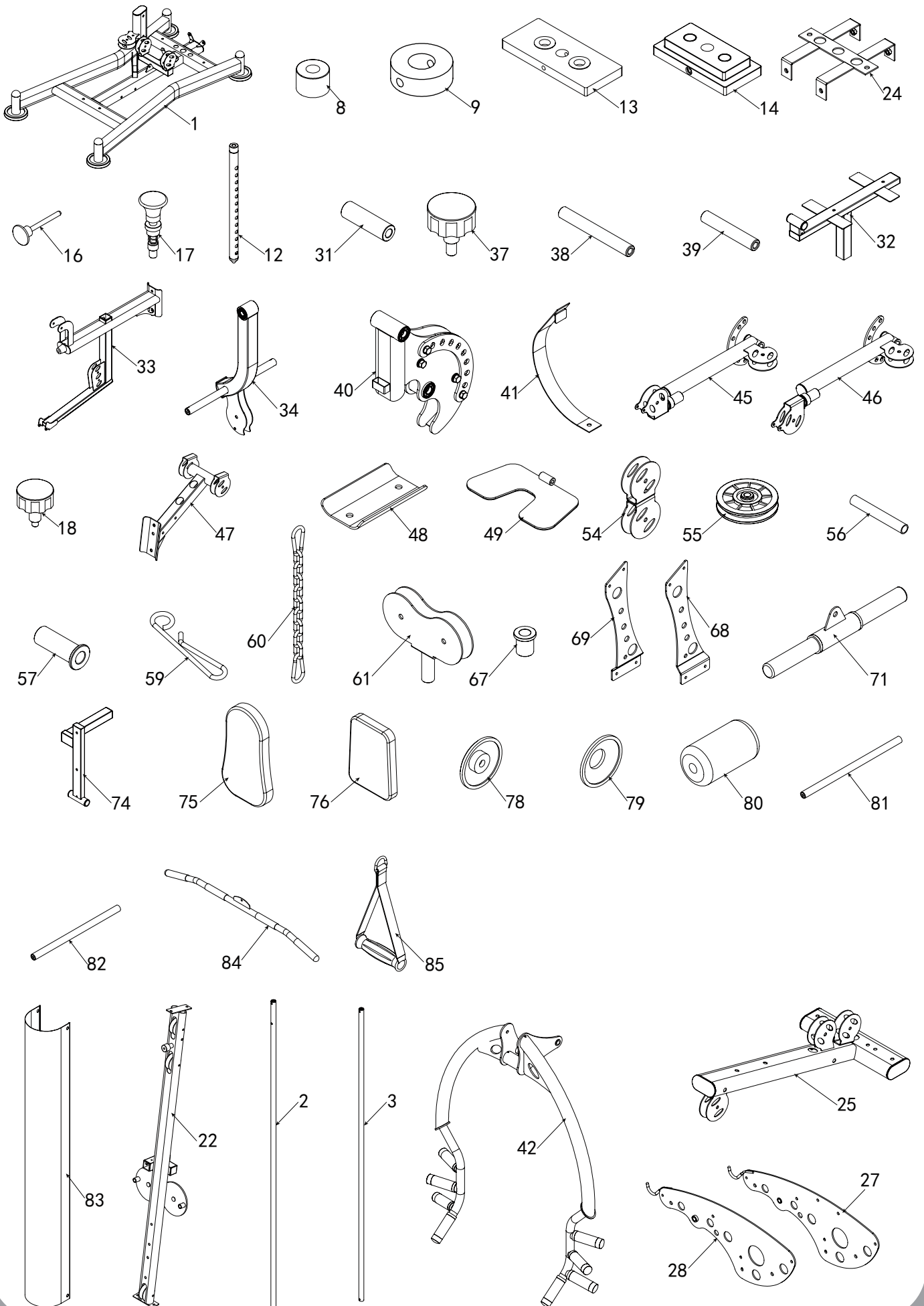

Cable drawing

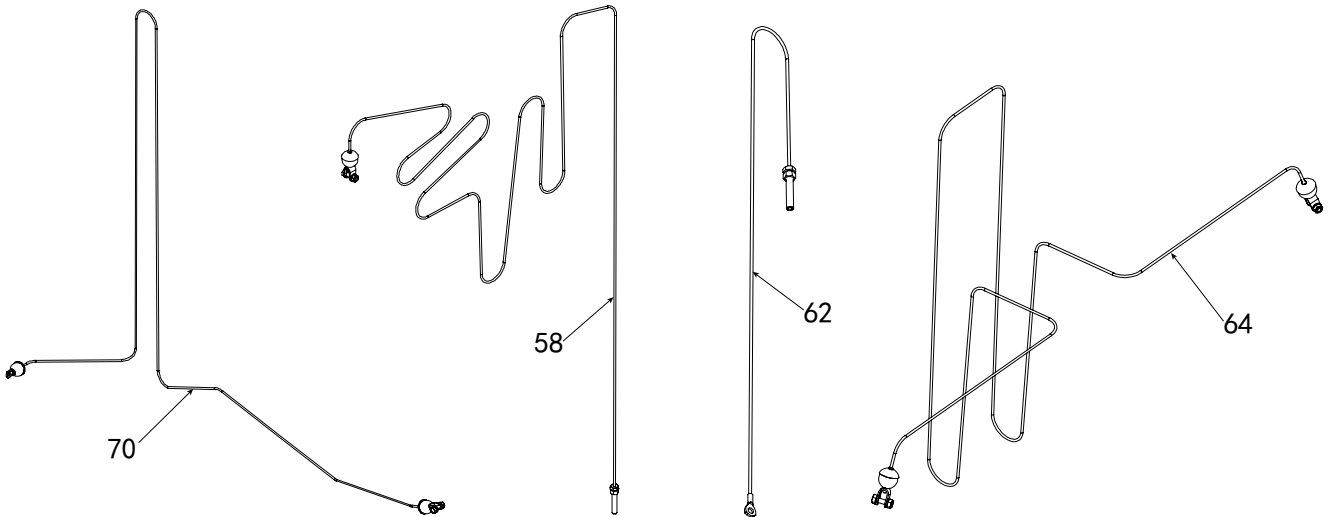

Fasteners drawing

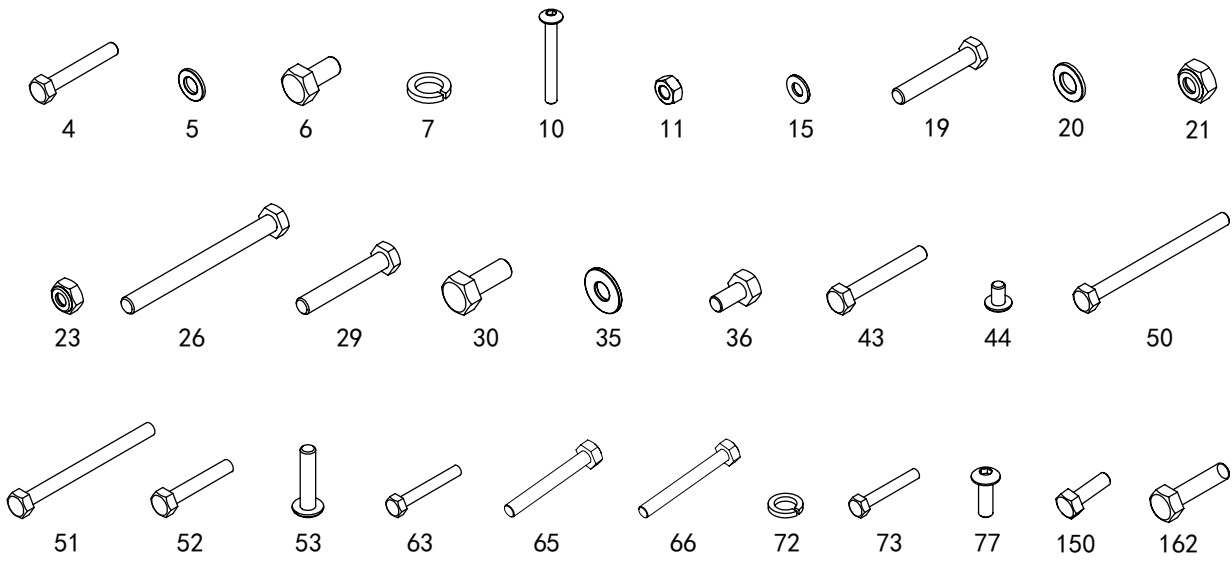

Bolt length measurement ruler



Assembly step (1) explosion drawing

No.	Description	Note	Qty.
1	ground frame		1
2	guide rod	$\Phi 25*1853$	2
3	back support rod	$\Phi 259*1757.5$	2
4	hexagon bolt	$M10*65$	2
5	washer	$\Phi 10$	4
6	hexagon bolt	$M10*20$	2
7	spring washer	$\Phi 10$	4
8	rubber cushion	$\Phi 60*\Phi 26*42$	2

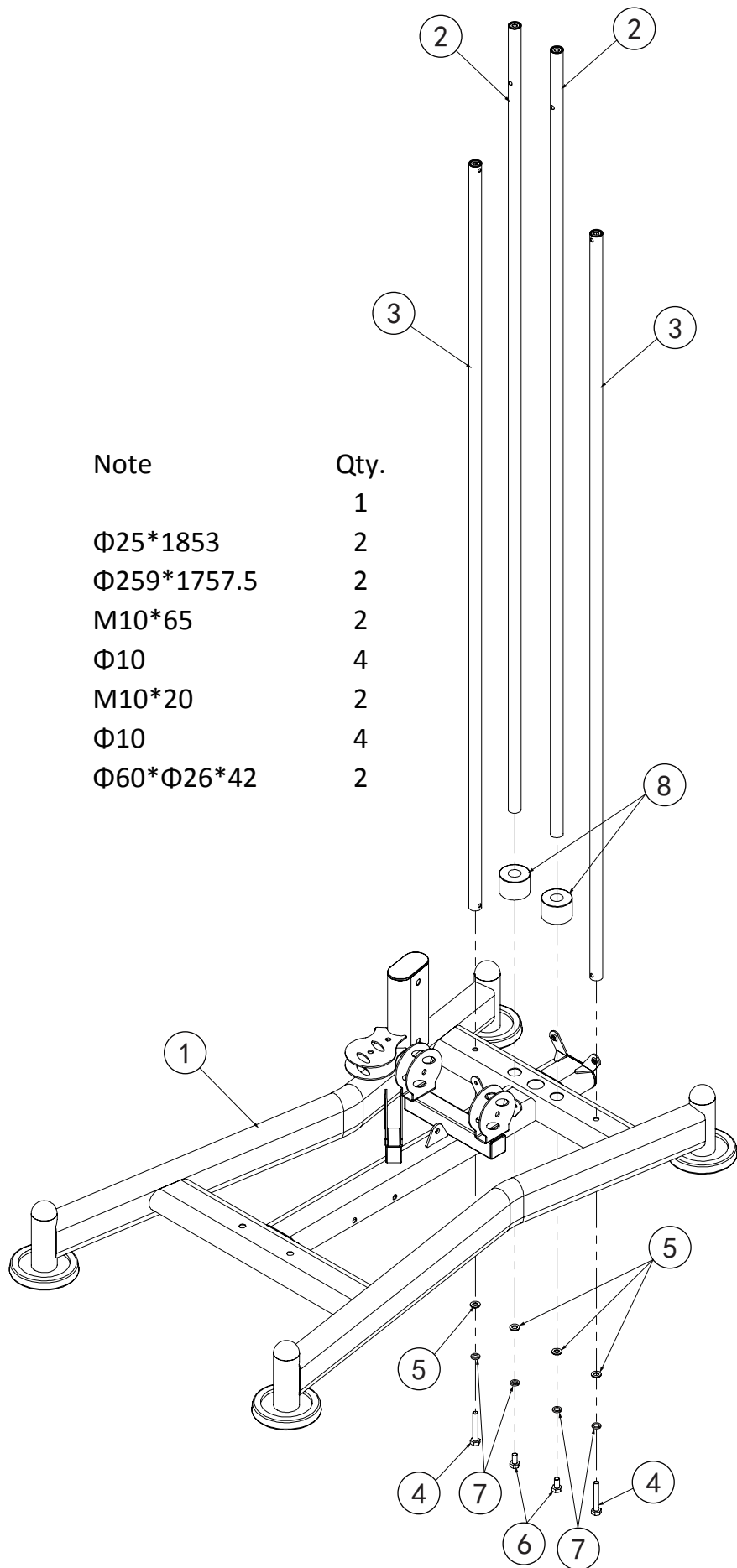

Assembly step (1) drawing

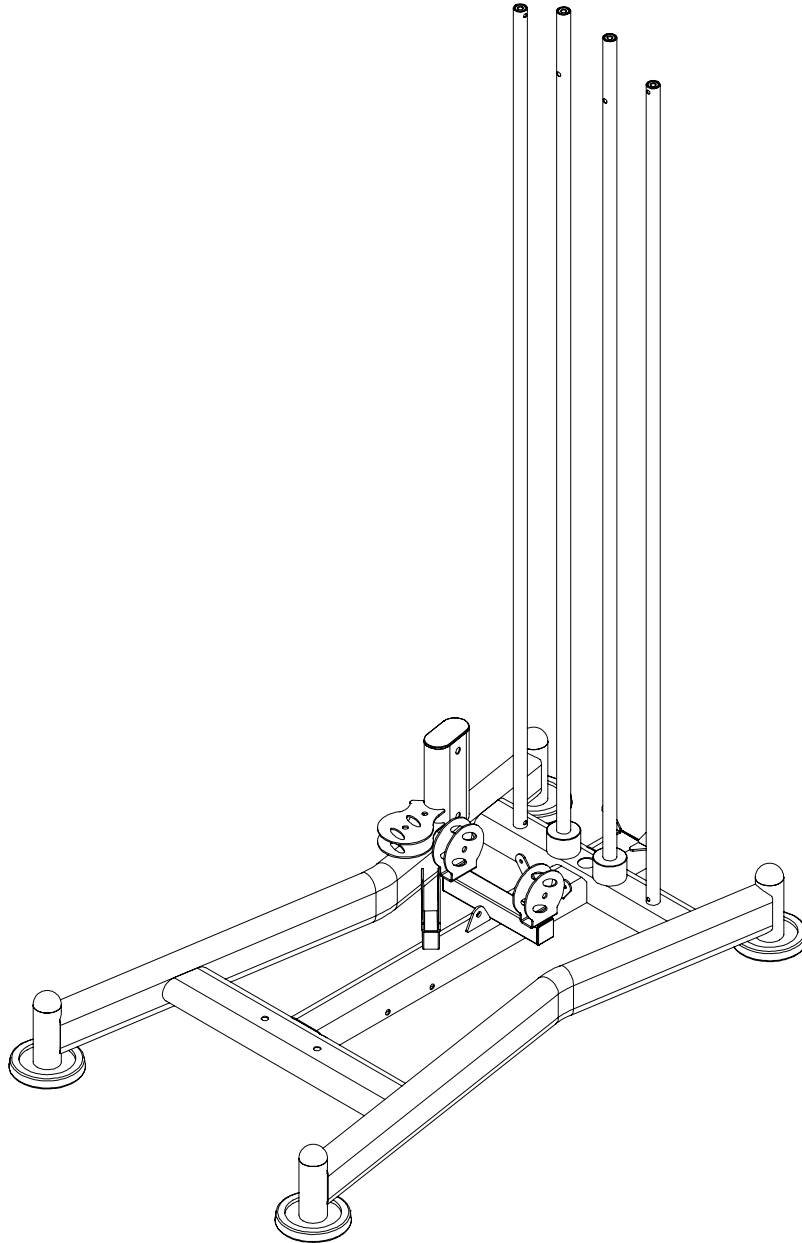

Assembly step (1) assembly instruction

1. Fix back support rod(3) on ground frame(1) using:
M10*65 hexagon bolt(4), $\Phi 10$ spring washer(7), $\Phi 10$ washer(5)
2. Fix guide rod(2) on ground frame(1) using:
M10*20 hexagon bolt(6), $\Phi 10$ spring washer(7), $\Phi 10$ washer(5)
3. Put rubber damper(8) on guide rod(2)

CAUTION: All bolts should be tightening.

Assembly step (2) explosion drawing

No.	Description	Note	Qty.
9	counter weight rubber cushion	$\Phi 60 * \Phi 26 * 20$	2
10	hexagon socket button head bolt	M8*70	2
11	lock nut	M8	2
12	selector rod	92 KG	1
13	counter weight	6 KG	14
14	topmost counter weight	8 KG	1
15	washer	$\Phi 8$	4
16	weight pin	$\Phi 10 * 100$	1

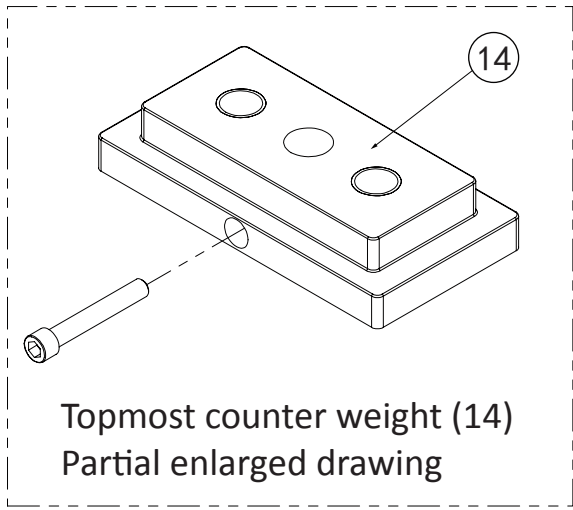
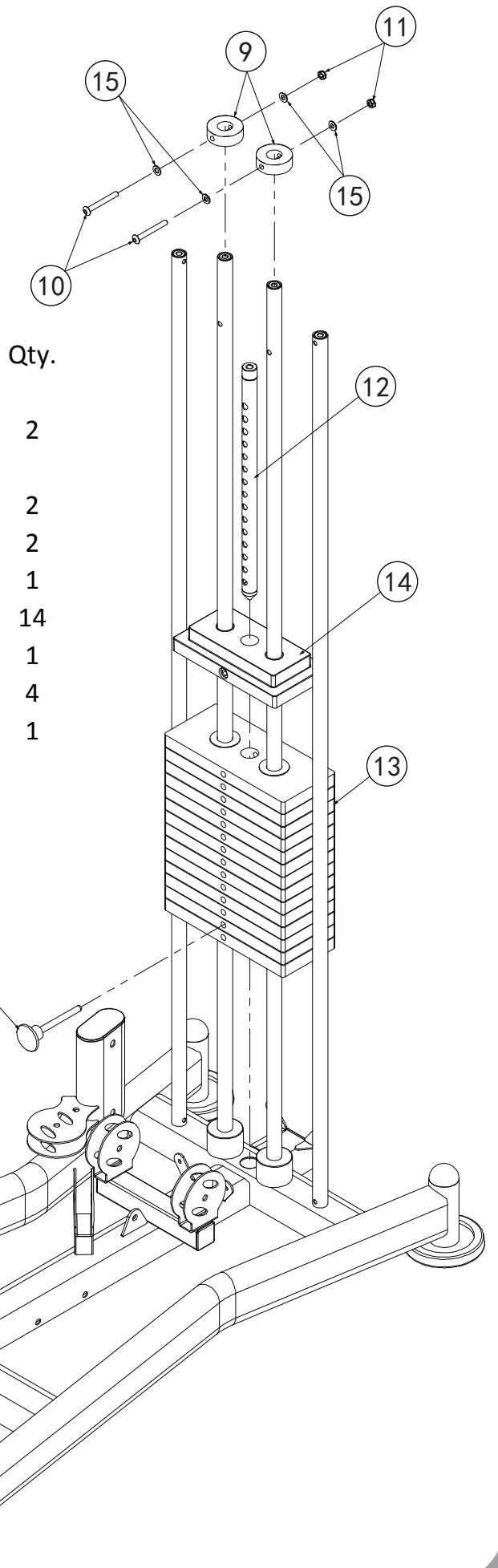

Assembly step (2) drawing

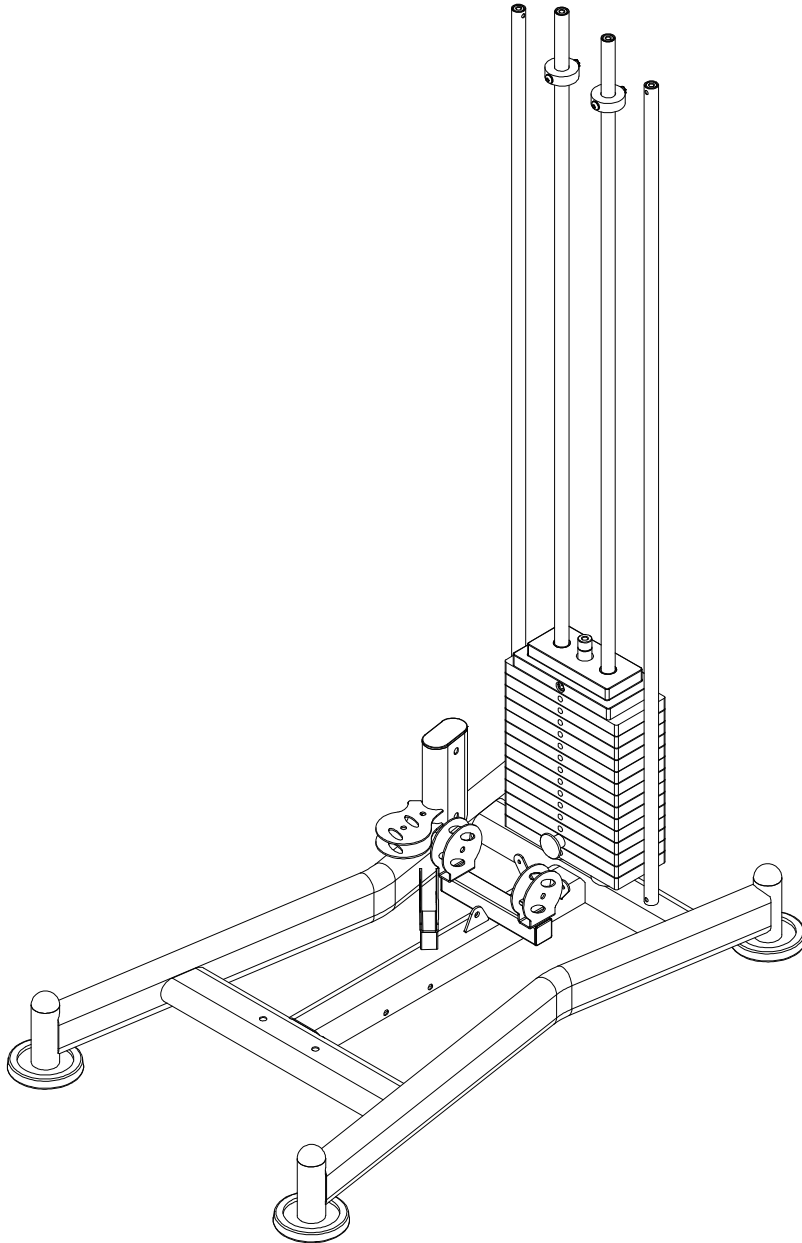

Assembly step (2) assembly instruction

1. From guide rod top in turn put 14pcs counter weight(13), topmost counter weight(14); among put topmost counter weight(14) on the top
2. Remove the bolt from the topmost counter weight(14),then lower the selector rod(12) into counter weights central, final install the bolt back to topmost counter weight(12)
3. Fix counter weight rubber cushion(9) in the topmost hole in guide rod using:
in each case-one M8*70 hexagon socket button head bolt(10),two $\Phi 8$ washer(15)
and one M8 lock nut(11)
4. Insert weight pin(16) into the front of the second-to-bottom counter weight

CAUTION: All bolts should be tightening.

Assembly step (3) explosion drawing

No.	Description	Note	Qty.
17	lock pin		2
18	pull pin	Φ10	1
19	hexagon bolt	M12*70	2
20	washer	Φ12	4
21	lock nut	M12	2
22	front frame		1

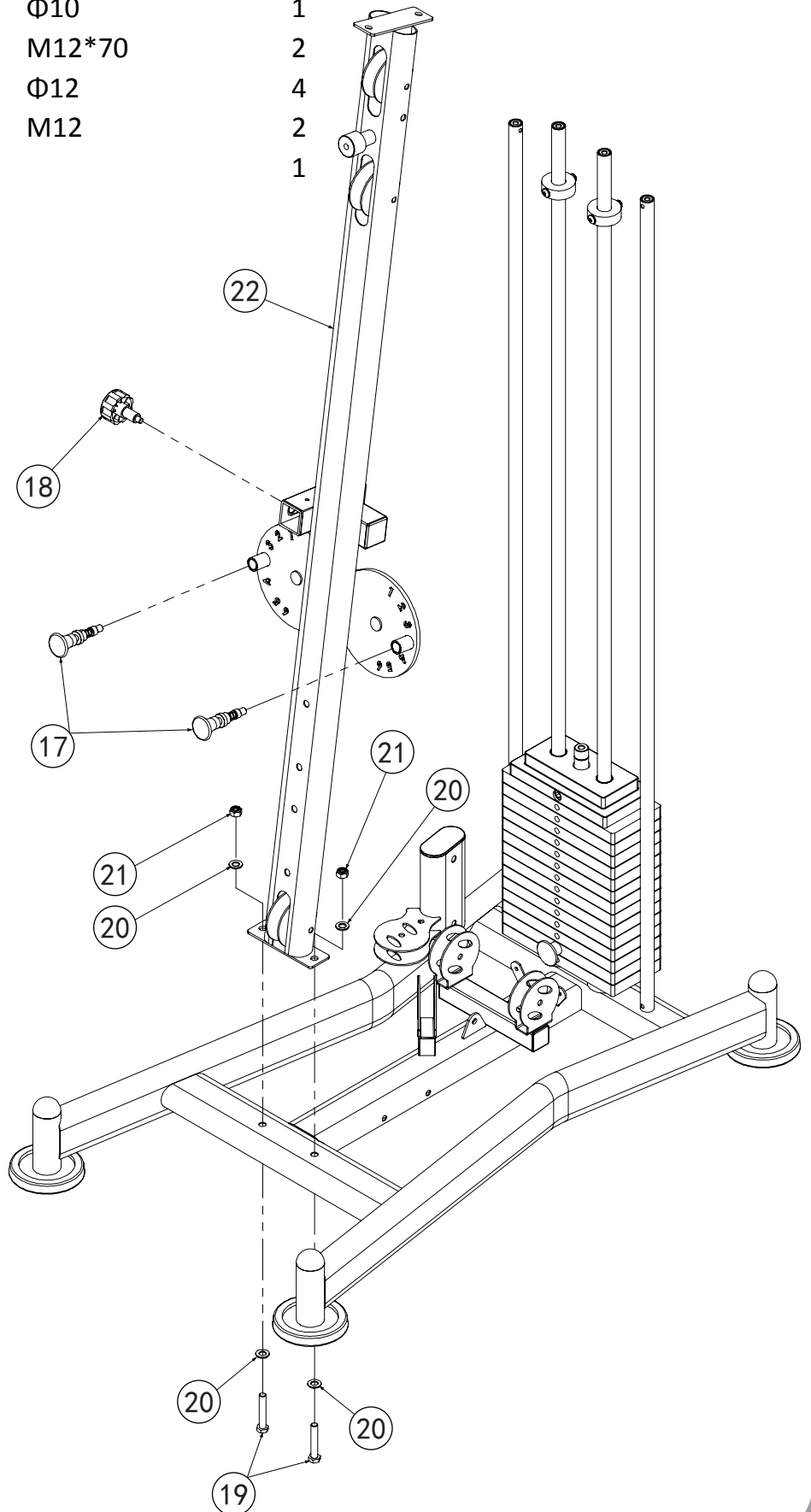

Assembly step (3) drawing

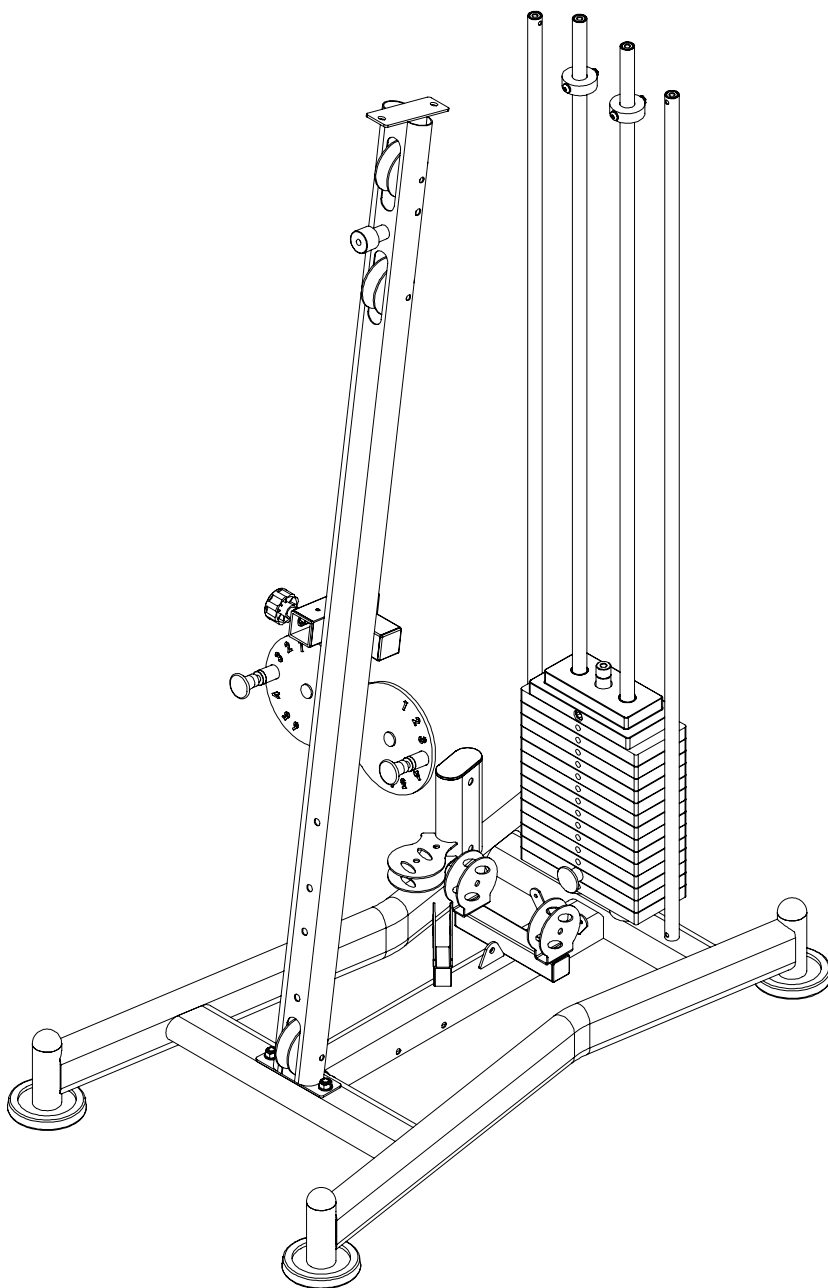

Assembly step (3) assembly instruction

1. Fix front frame(22) on ground frame(1) using:
M12*70 hexagon bolt(19), Φ 12washer(20), M12 lock nut(21)
2. Put lock pin(17) on front frame(22)
3. Put pull pin(18) on front frame(22)

CAUTION: All bolts should be tightening.

Assembly step (4) explosion drawing

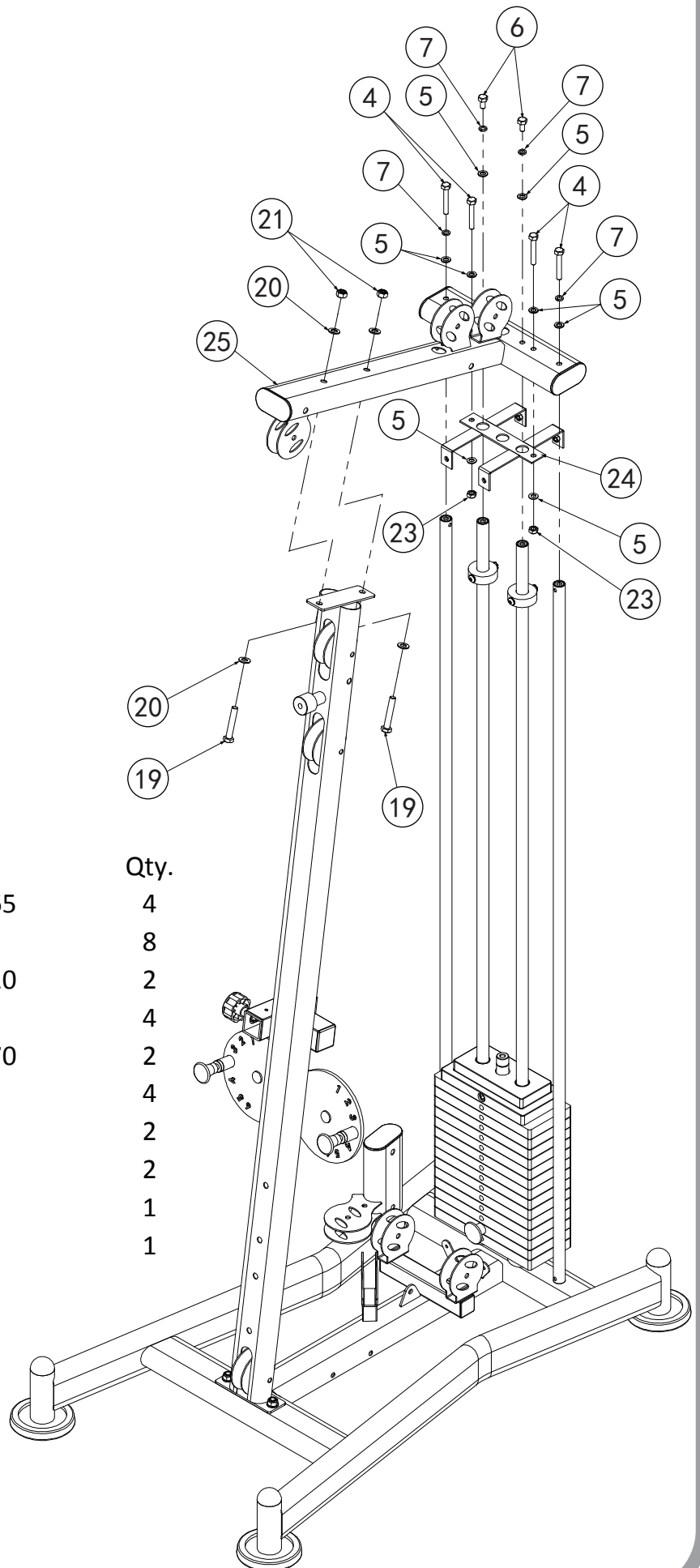

No.	Description	Note	Qty.
4	hexagon bolt	M10*65	4
5	washer	Φ10	8
6	hexagon bolt	M10*20	2
7	spring washer	Φ10	4
19	hexagon bolt	M12*70	2
20	washer	Φ12	4
21	lock nut	M12	2
23	lock nut	M10	2
24	shield support frame		1
25	upper frame		1

Assembly step (4) drawing

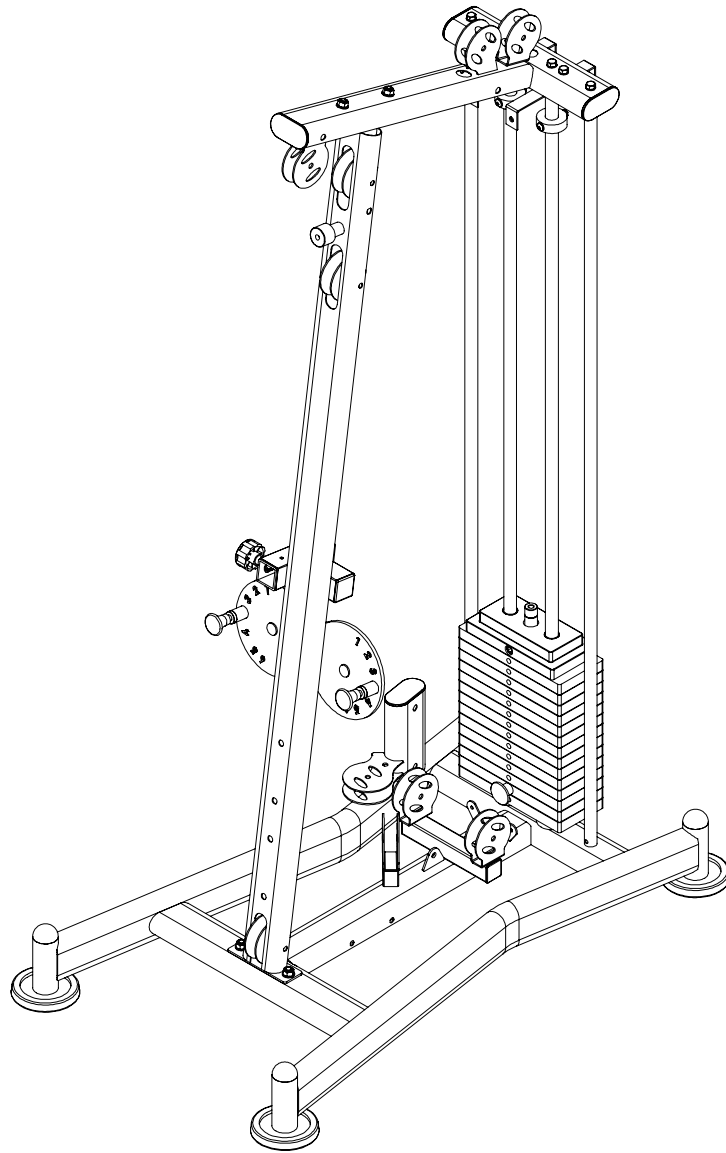

Assembly step (4) assembly instruction

1. Fix shield support frame(24) and guide rod
2. Fix upper frame (25) fastening with guide rod using:
M10*20 hexagon bolt(6), Φ 10 spring washer(7), Φ 10 washer(5)
3. Fix upper frame (25) fastening on front frame using:
M12*70 hexagon bolt(19), Φ 12 washer(20),M12 lock nut(21)
4. Fix upper frame (25) fastening on back support rod using:
M10*65 hexagon bolt(4), Φ 10 spring washer(7), Φ 10 washer(5)
5. Fix shield support frame(24) fastening on upper frame(15) using:
M10*65 hexagon bolt(4), Φ 10 washer(5),M10 lock nut(23)

CAUTION: All bolts should be tightening.

Assembly step (5) explosion drawing

No.	Description	Note	Qty.
20	washer	Φ12	6
21	lock nut	M12	3
26	hexagon bolt	M12*130	3
27	right cover		1
28	left cover		1

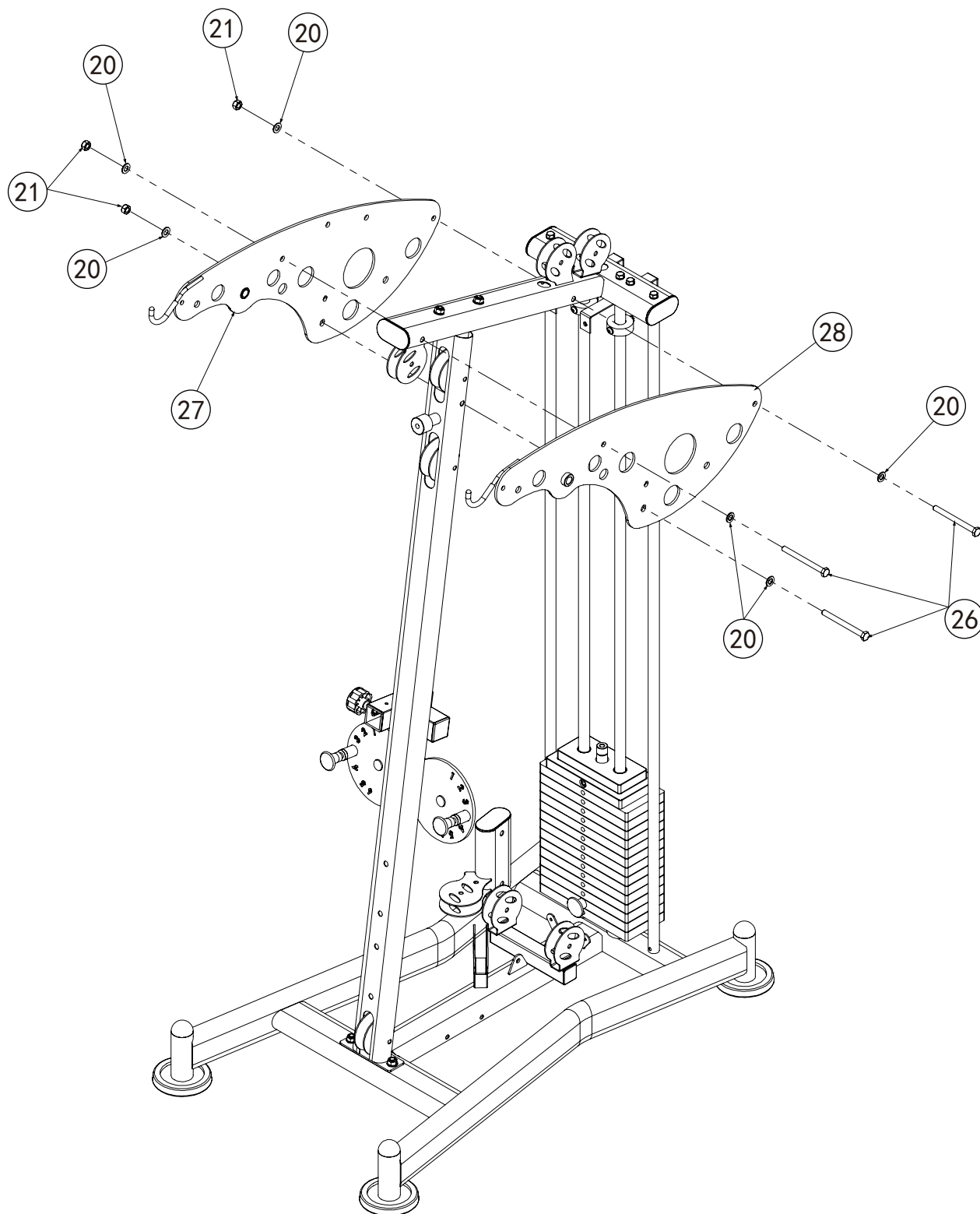

Assembly step (5) drawing

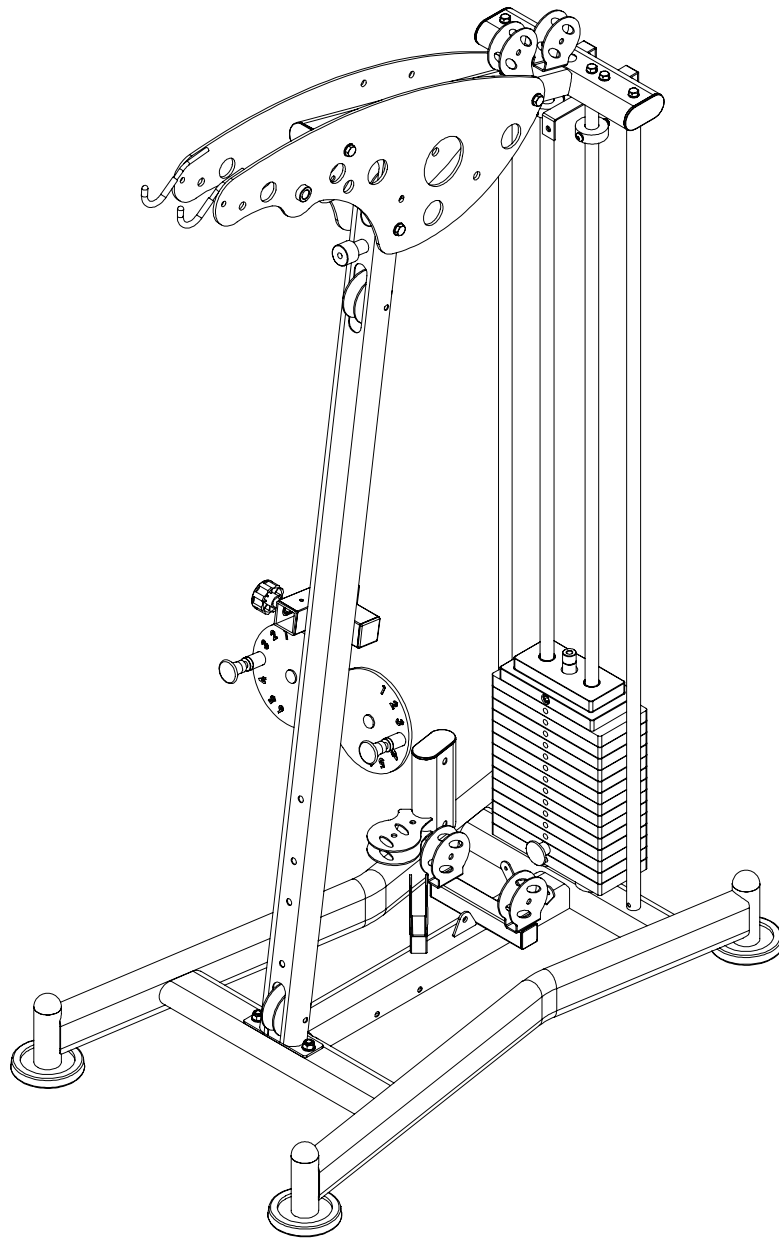

Assembly step (5) assembly instruction

Fix right cover(27) and left cover(28) on upper frame using:
M12*130 hexagon bolt(26)
Φ12 washer(20)
M12 lock nut(21)

CAUTION: All bolts should be tightening.

Assembly step (6) explosion drawing

No.	Description	Note	Qty.
5	washer	Φ10	2
7	spring washer	Φ10	2
18	pull pin	Φ10	1
20	washer	Φ12	4
21	lock nut	M12	2
29	hexagon bolt	M12*75	2
30	hexagon bolt	M10*25	2
31	axis of rotation	Φ17*57	1
32	seat cushion adjust frame		1
33	seat cushion tube		1
34	leg curl elbow tube		1

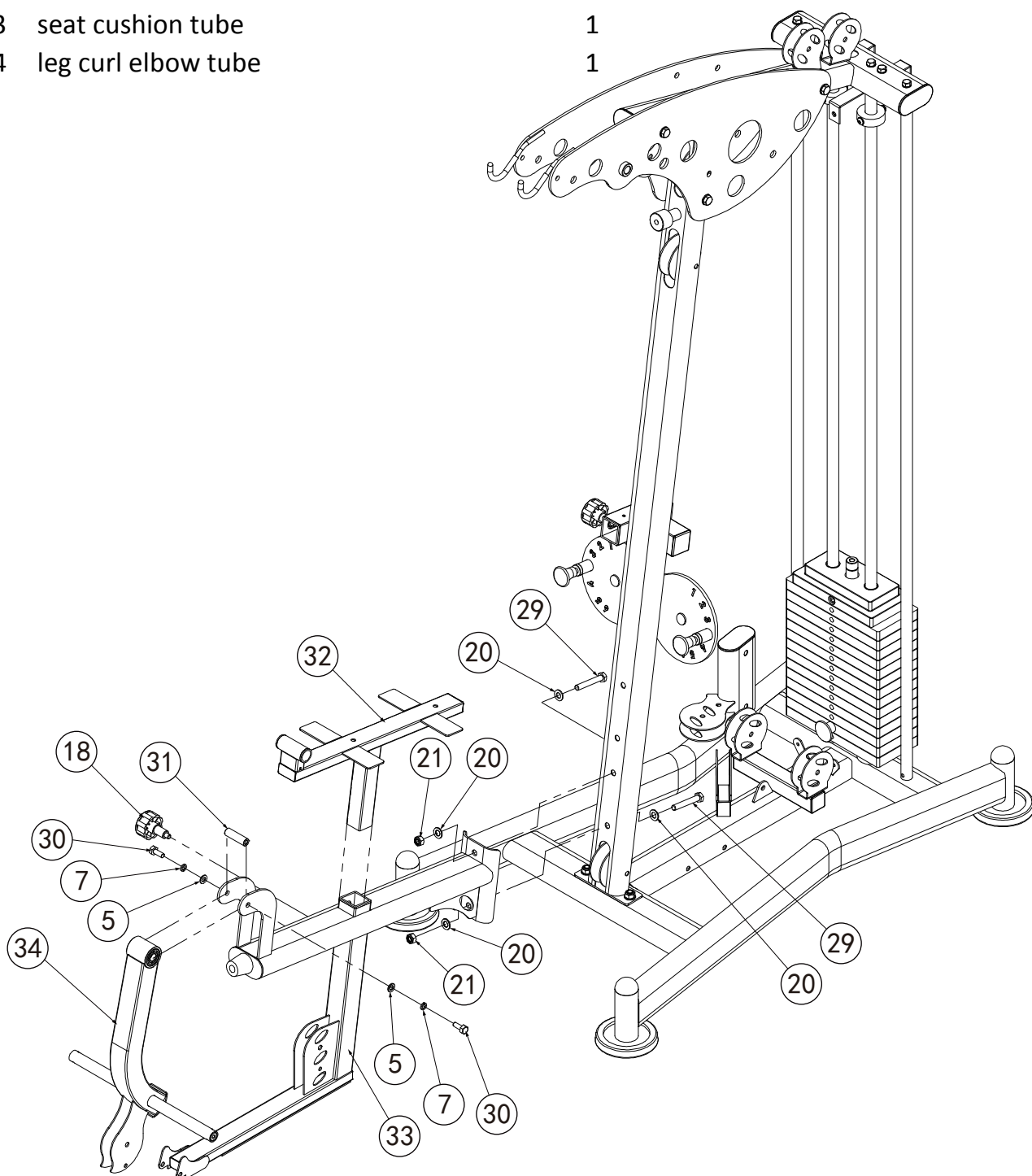

Assembly step (6) drawing

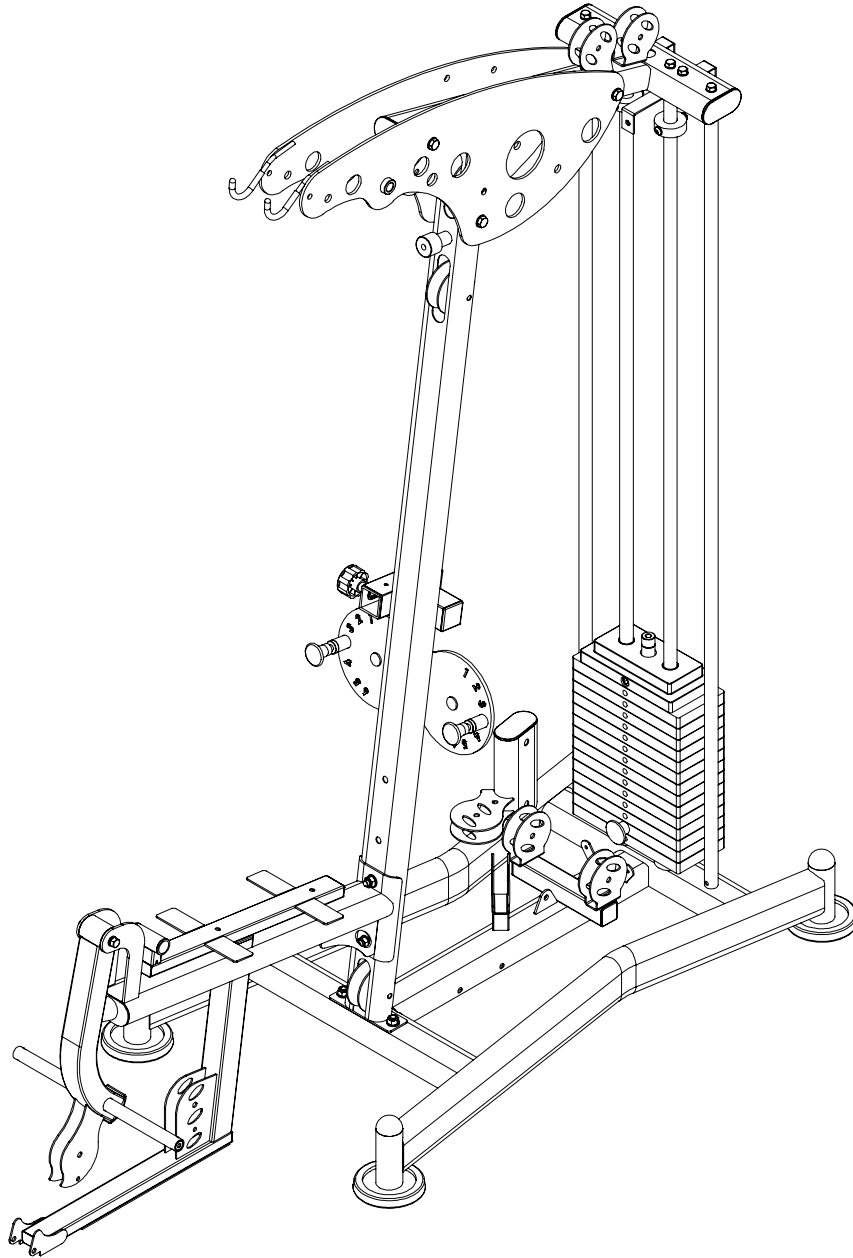

Assembly step (6) assembly instruction

1. Fix seat cushion tube(33) fastening on front frame using:
M12*75 hexagon bolt(29), Φ 12 washer(20),M12 lock nut(21)
2. Fix leg curl elbow tube(34) on seat cushion tube(33) using:
axis of rotation(31),M10*25 hexagon bolt(30), Φ 10 spring washer(7), Φ 10 washer(5)
3. Fix seat cushion adjust frame(32) fastening on seat cushion tube(33) using: pull pin(18)

CAUTION: All bolts should be tightening.

Assembly step (7) explosion drawing

No.	Description	Note	Qty.
6	hexagon bolt	M10*20	4
7	spring washer	Φ10	2
15	washer	Φ8	1
35	big washer	Φ25*10*2.0	4
36	hexagon bolt	M8*16	1
37	pull pin	Φ12	1
38	shaft	Φ17*134	1
39	shaft	Φ17*100	1
40	front push holder		1
41	guard plate		1
42	front push arm		1

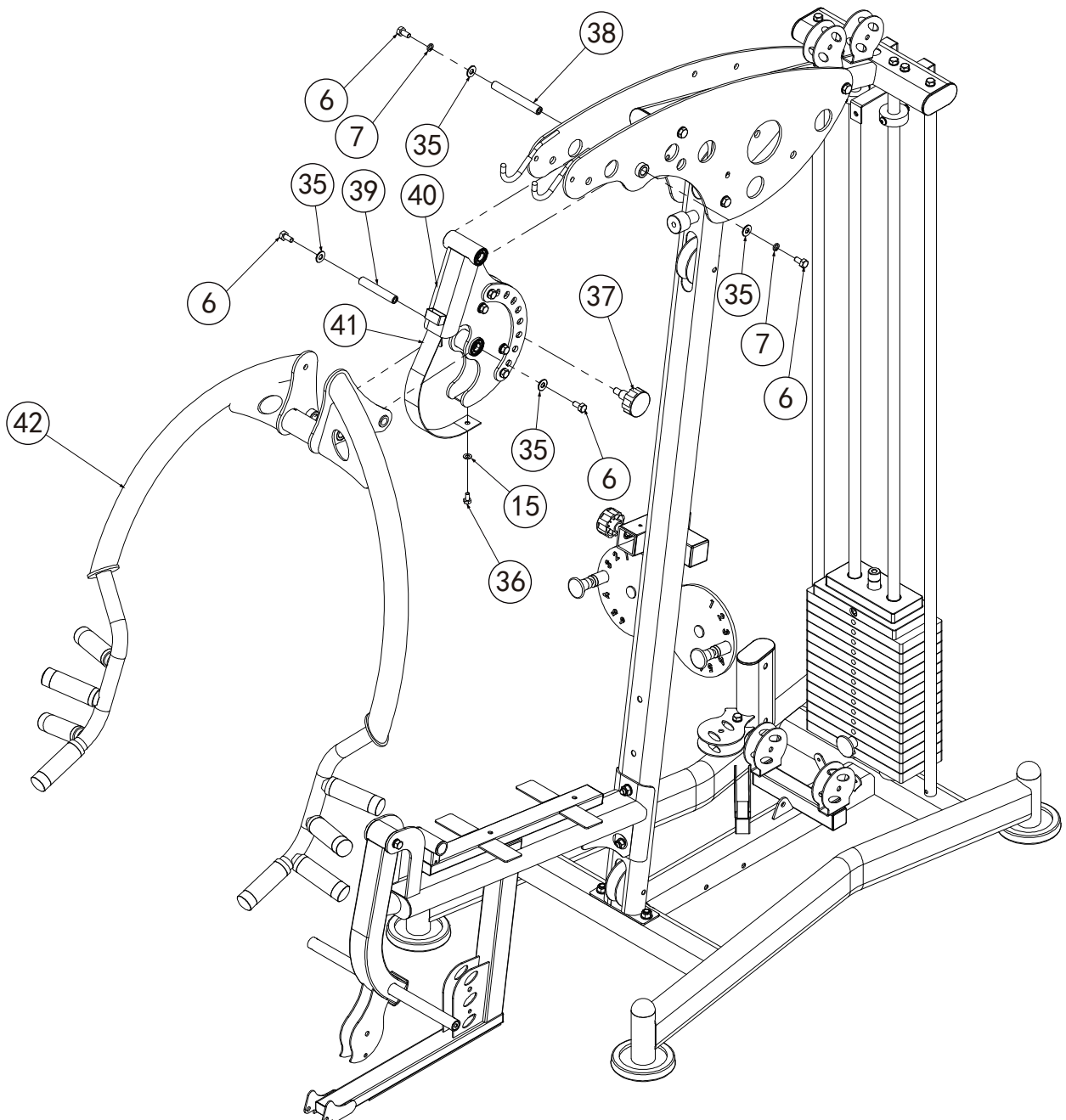

Assembly step (7) drawing

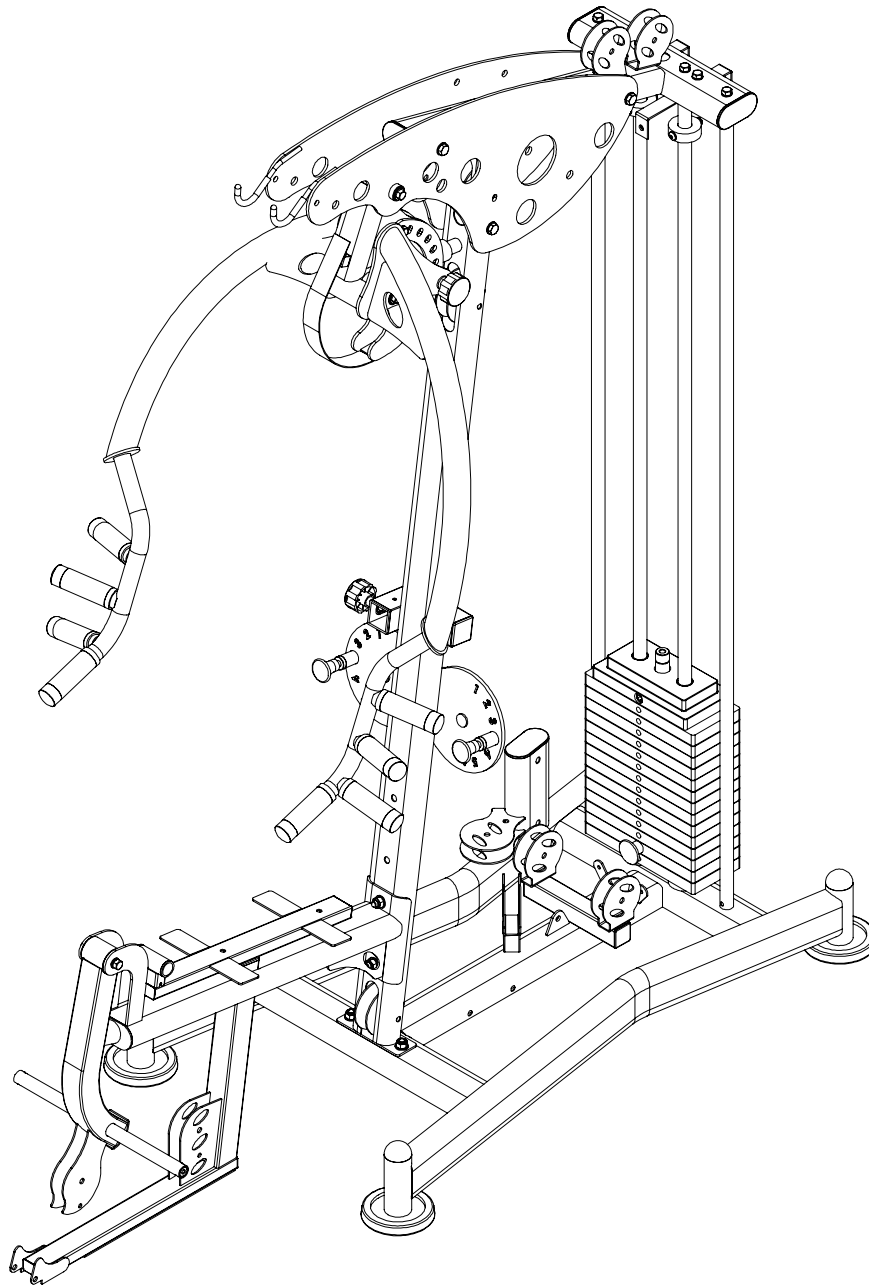

Assembly step (7) assembly instruction

1. Fix front push holder(40) on left cover & right cover using:
shaft(38),M10*20 hexagon bolt(6), Φ 10 spring washer(7), Φ 10 big washer(35)
2. Fix front push arm(42) and front push holder(40) using:
shaft(39),M10*20 hexagon bolt(6), Φ 10 big washer(35),pull pin(37)
3. Fix guard plate(41) on front push holder(40) using:
M8*16 hexagon bolt(36), Φ 8 washer(15)

CAUTION: All bolts and pins should be tightening.

Assembly step (8) explosion drawing

No.	Description	Note	Qty.
5	washer	Φ10	2
7	spring washer	Φ10	2
21	lock nut	M12	4
20	washer	Φ12	2
23	lock nut	M10	1
29	hexagon bolt	M12*75	2
35	big washer	Φ25*10*2.0	2
43	hexagon bolt	M10*70	1
44	hexagon socket button head bolt	M10*16	2
45	right butterfly arm		1
46	left butterfly arm		1
47	pulley support frame		1
48	reinforcing plate		1
49	footplate		1

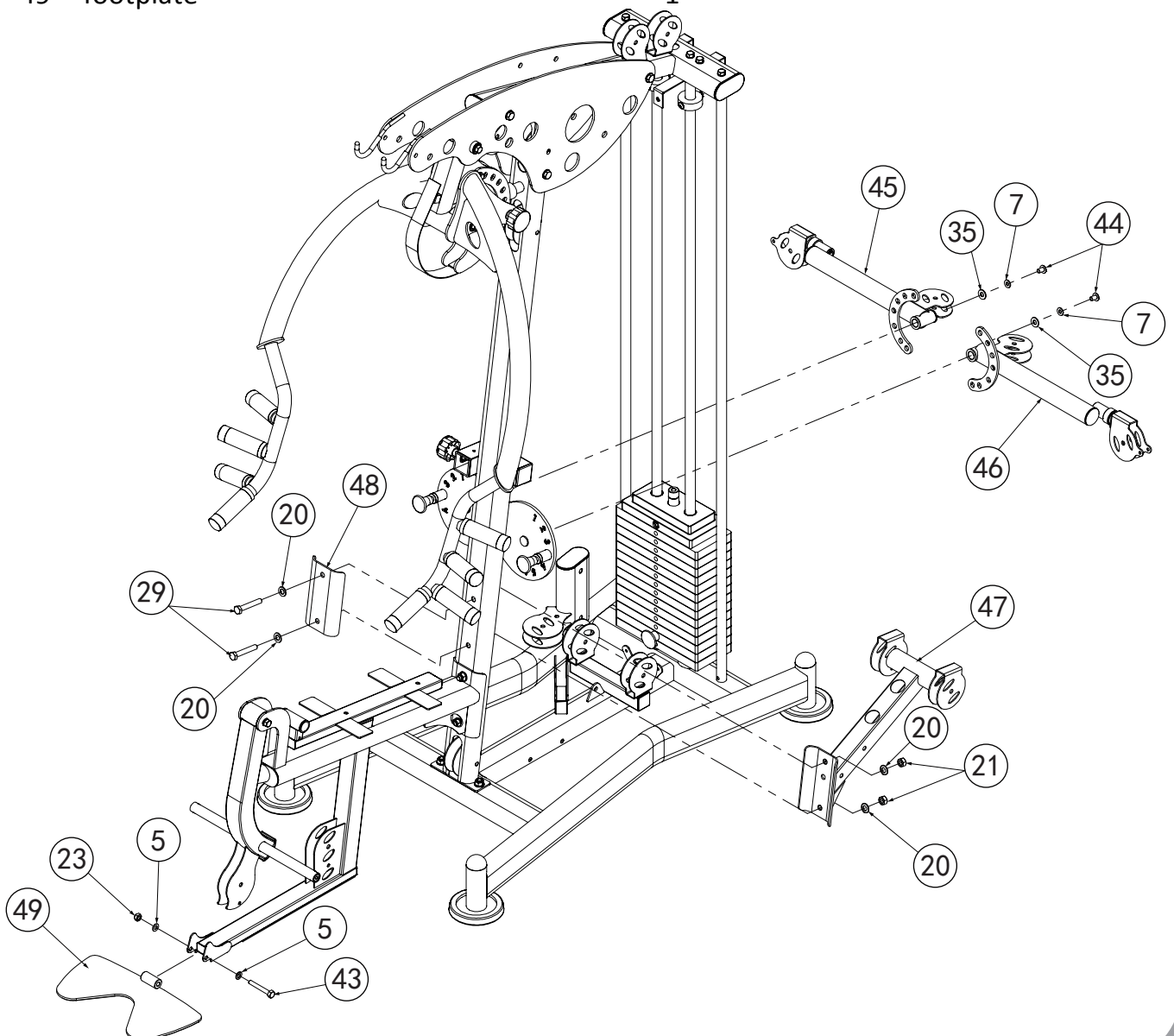

Assembly step (8) drawing

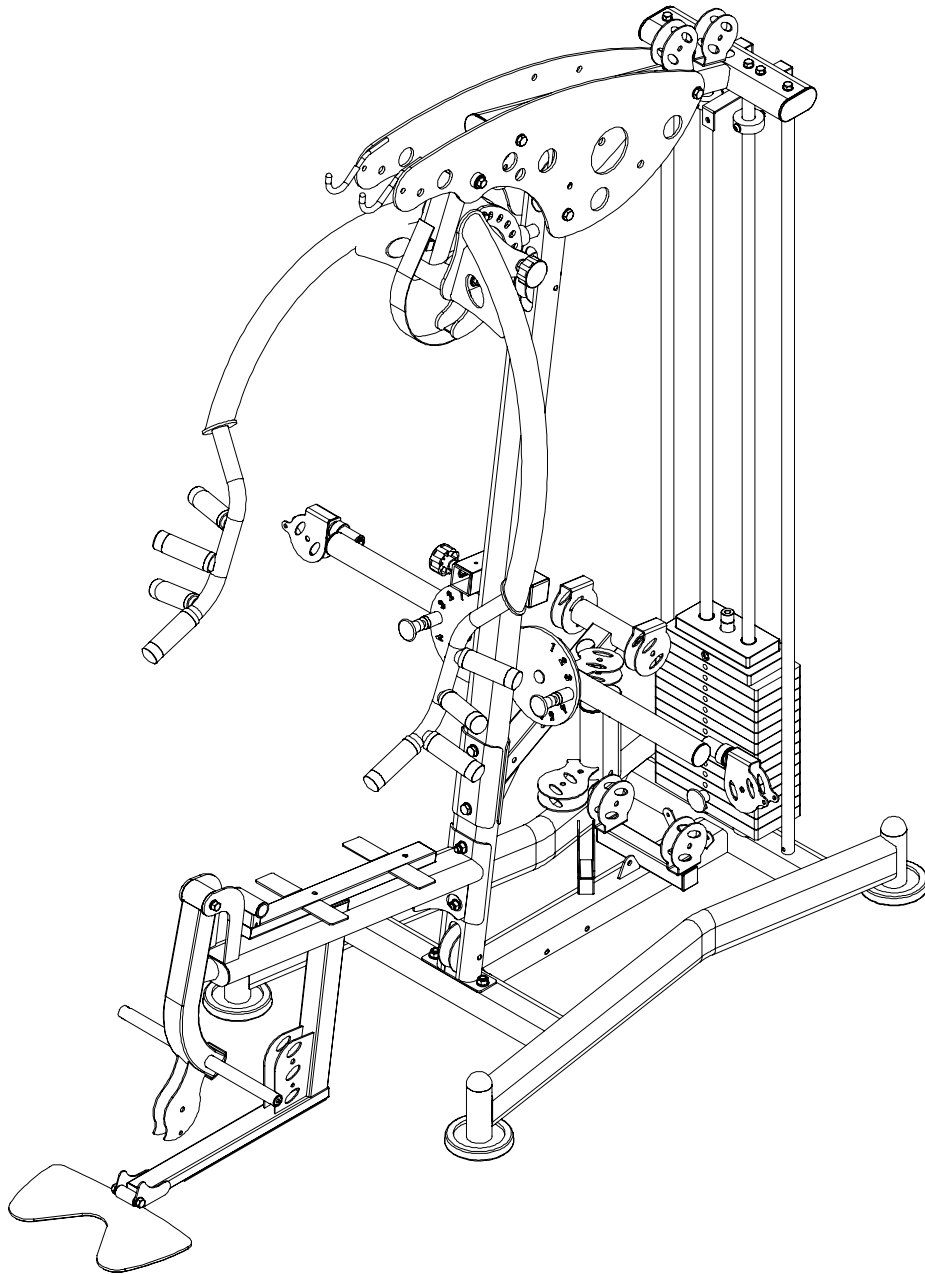

Assembly step (8) assembly instruction

1. Fix left butterfly arm(46) on front frame using:
M10*16 hexagon socket button head bolt(44), Φ 10 spring washer(7), Φ 10 big washer(35)
2. Fix right butterfly arm(45) on front frame using:
M10*16 hexagon socket button head bolt(44) Φ 10 spring washer(7), Φ 10 big washer(35)
3. Fix pulley support frame(47) on front frame using:
M12*75 hexagon bolt(29), Φ 12 washer(20), Φ 12 lock nut(21),reinforcing plate(48)
4. Fix footplate(49) on seat cushion tube using:
M10*70 hexagon bolt(43), Φ 10 washer(5),M10 lock nut(23)

CAUTION: All bolts and pins should be tightening.

Assembly step (9) explosion drawing

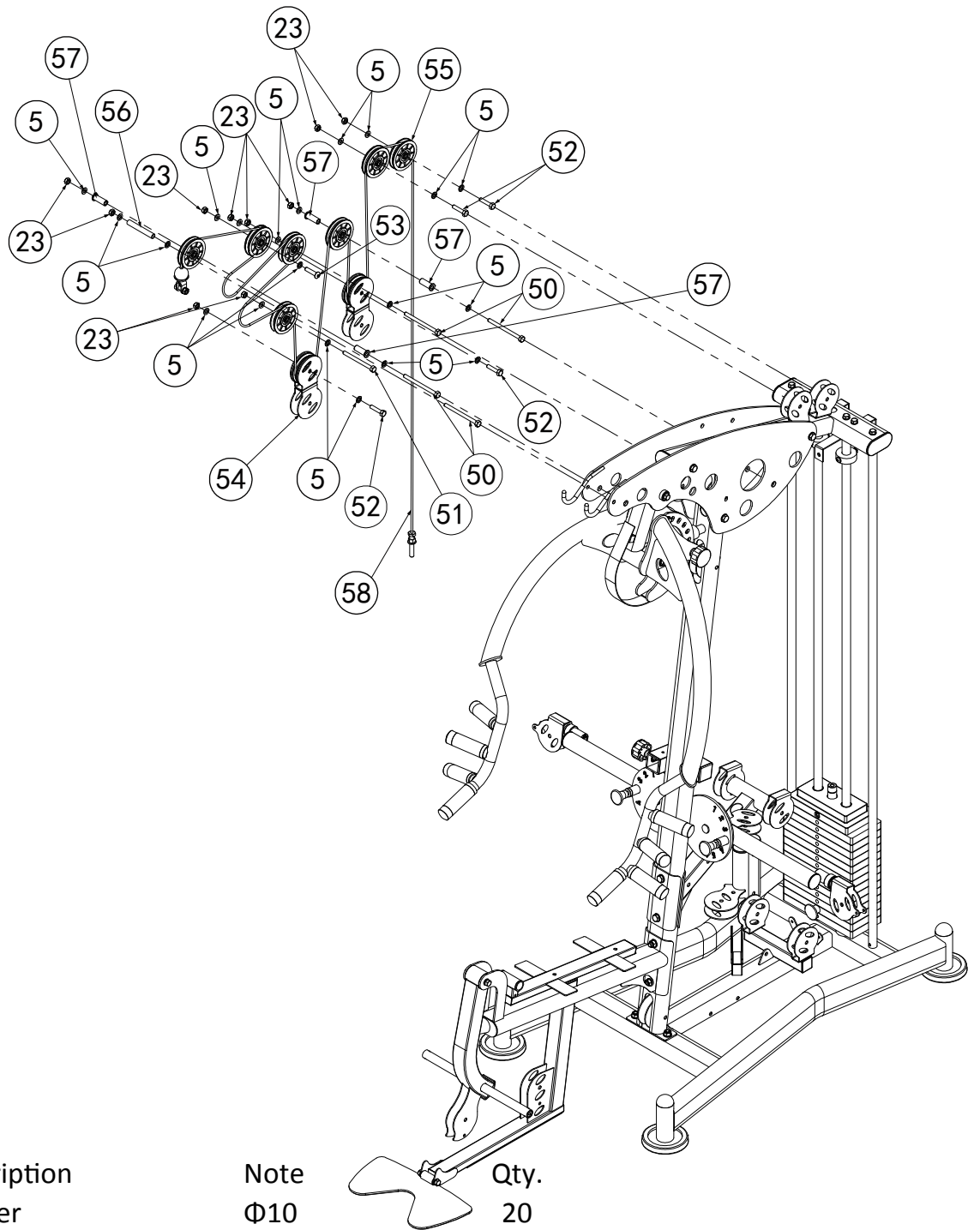

No.	Description	Note	Qty.
5	washer	Φ10	20
23	lock nut	M10	10
50	hexagon bolt	M10*130	4
51	hexagon bolt	M10*115	1
52	hexagon bolt	M10*45	4
53	hexagon socket button head bolt	M10*45	1
54	"- " shape pulley frame		2
55	pulley	Φ95*26	9
56	connecting sleeve	Φ14*100	1
57	pulley spacer	Φ22*Φ10.5*45.5	4
58	lat pull cable	L:4540mm	1

Assembly step (9) cable drawing

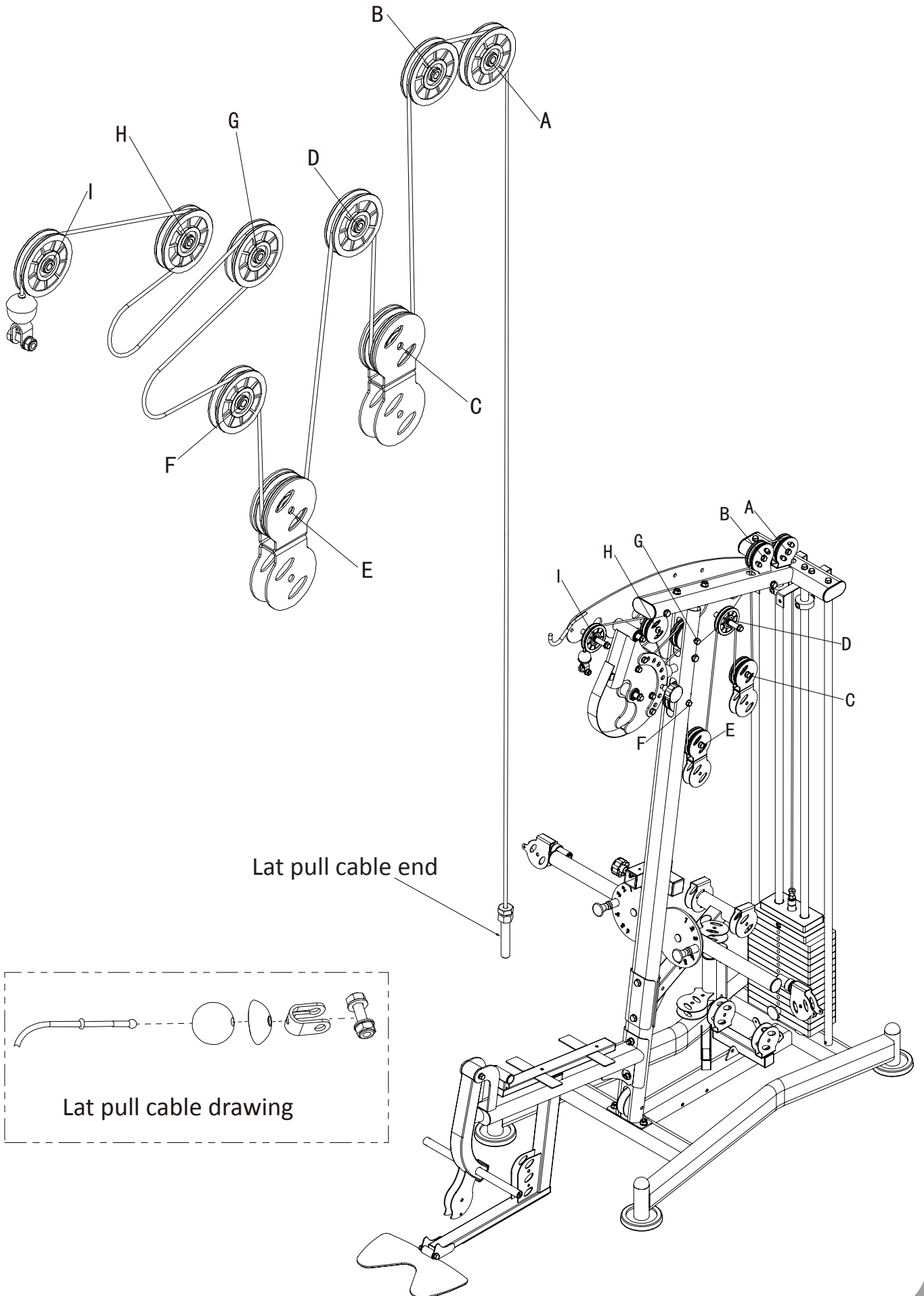

Assembly step (9) drawing

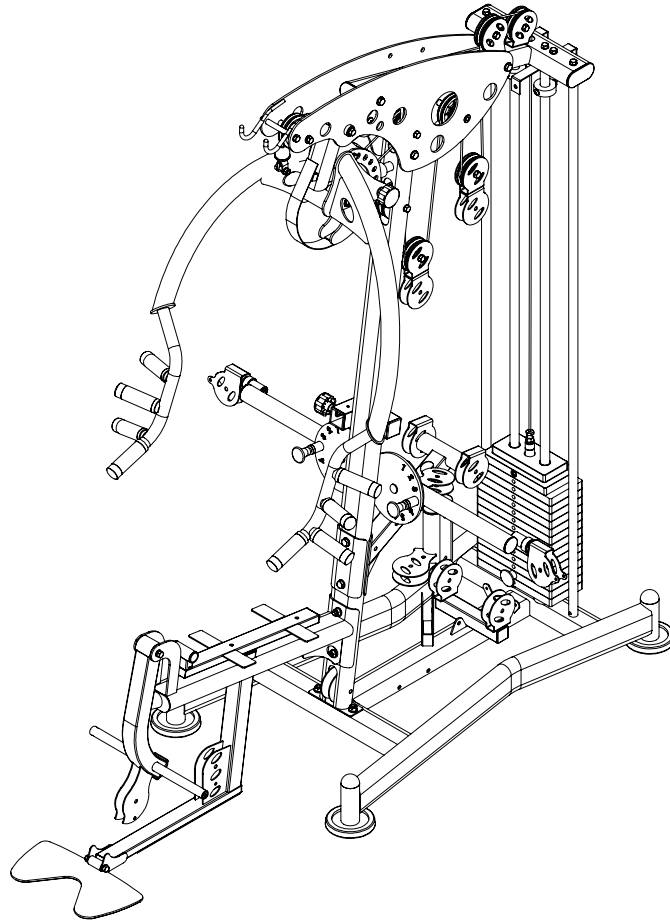

Assembly step (9) assembly instruction

1. Fix 4pcs pulley(55) fastening on pint: A ,B,C,E using:
M10*45 hexagon bolt(52), Φ 10 washer(5),M10 lock nut(23)
2. Fix 2pcs pulley(55) fastening on pint: I,D using:
M10*130 hexagon bolt(50),pulley spacer(57), Φ 10 washer(5),M10 lock nut(23)
3. Fix pulley(55) fastening on pint G using:
M10*130 hexagon bolt(50), Φ 10 washer(5),M10 lock nut(23)
4. Fix pulley(55) fastening on pint H using:
M10*45 hexagon socket button head bolt(63), Φ 10 washer(5),M10 lock nut(23)
5. Fix pulley(55) fastening on pint F using:
M10*115 hexagon bolt(51), Φ 10 washer(5),M10 lock nut(23)
6. Fix M10*130 hexagon bolt(50),connecting sleeve(56), Φ 10 washer(5),M10 lock nut(23)
fastening on left cover, right cover(near point I)
7. Remove lat pull cable(58) end which equipped ball head
8. Connect lat pull cable(58) terminal and selector rod,
head down end from point A in turn through point: B,C,D,E,F,G,H,I,
final installed ball head back to cable

Assembly step (10) explosion drawing

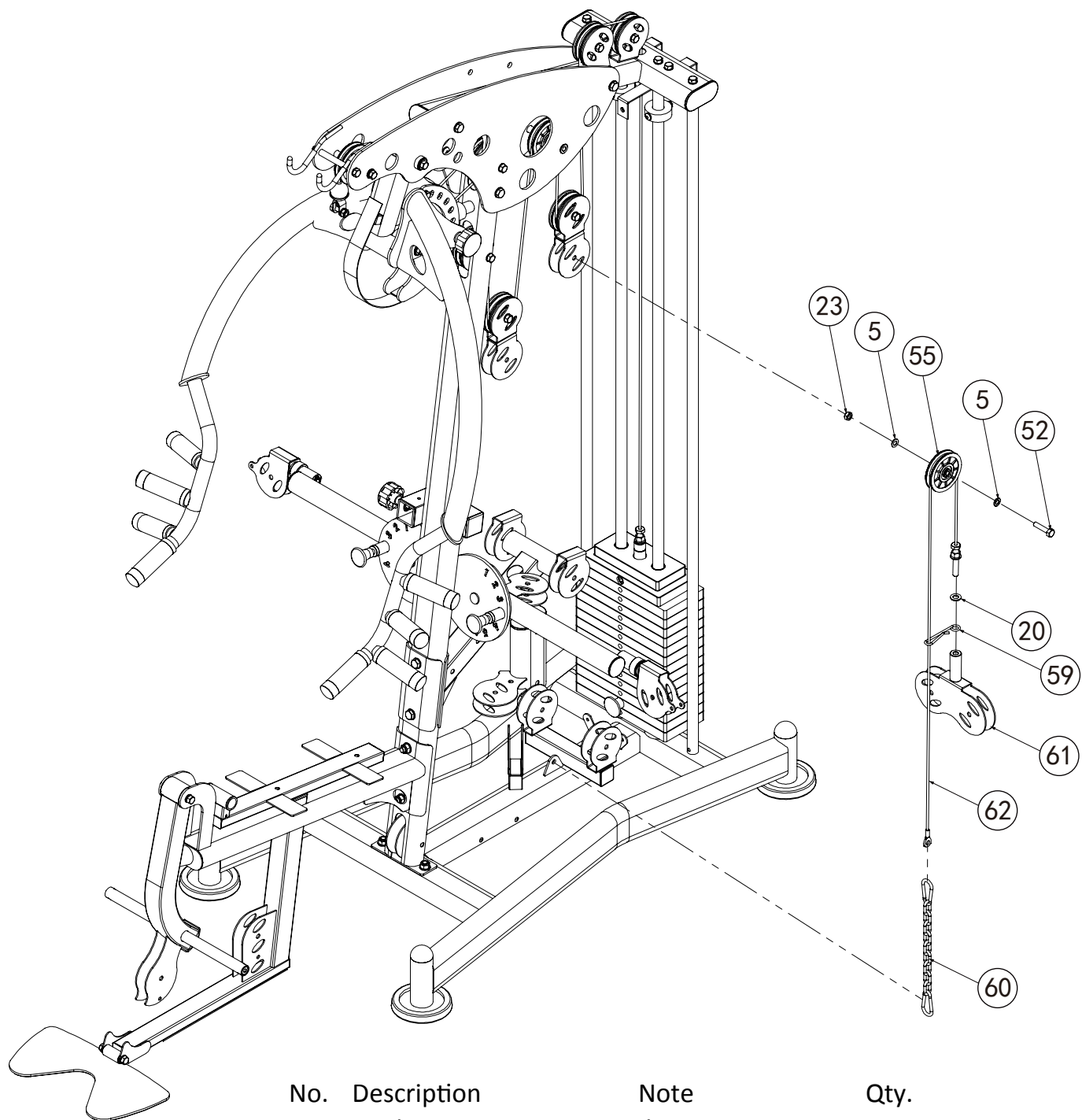

No.	Description	Note	Qty.
5	washer	Φ10	2
20	washer	Φ12	1
23	lock nut	M10	1
52	hexagon bolt	M10*45	1
55	pulley	Φ95*26	1
59	cable hook		1
60	9 link chain & snap hook		1
61	double pulley plate		1
62	middle cable	L:1500mm	1

Assembly step (10) drawing

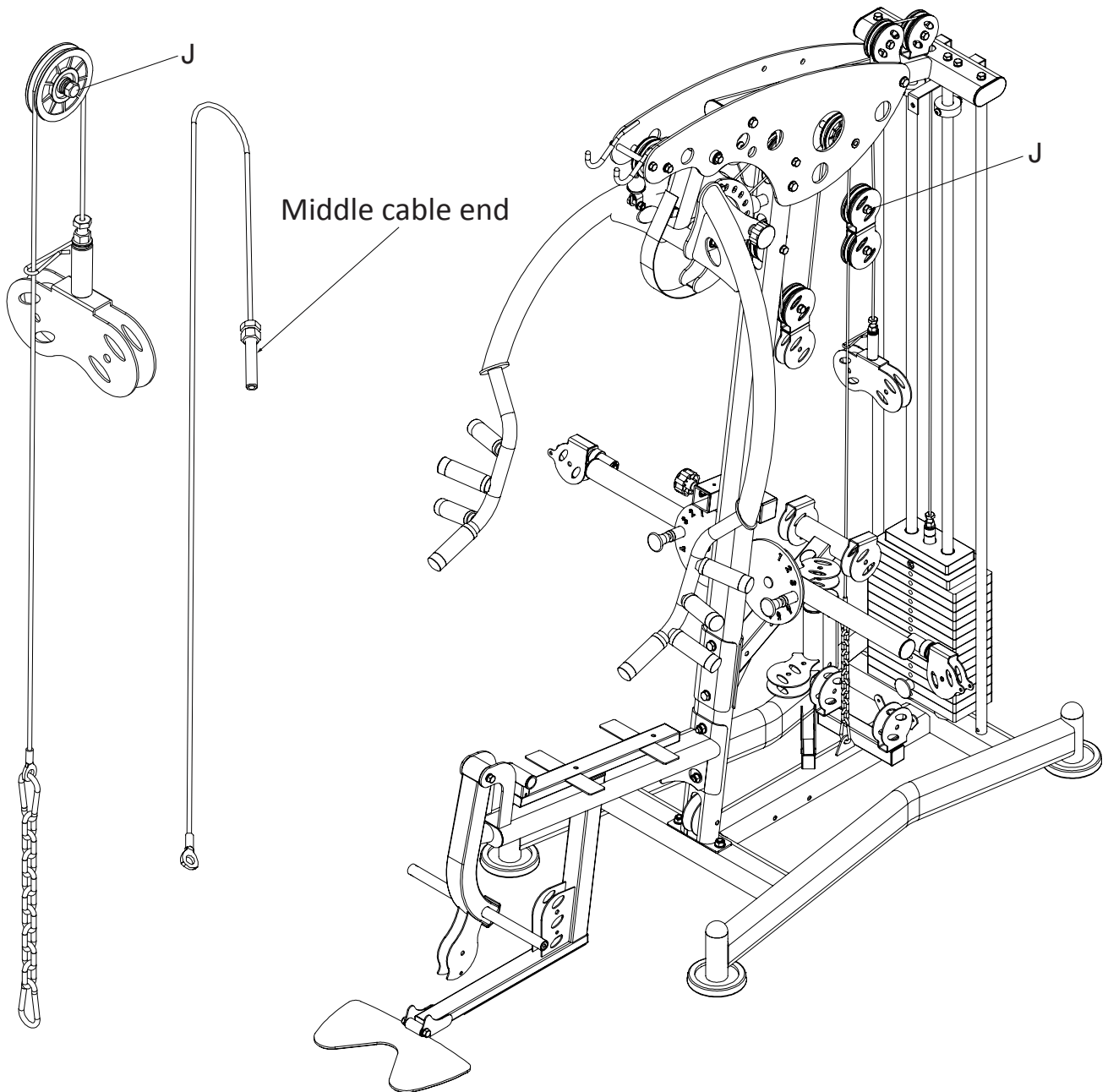

Assembly step (10) assembly instruction

1. Connect 9 link chain & snap hook(60) with middle cable(62)
9 link chain & snap hook(60) other end connect with ground frame
2. Middle cable(62) through $\Phi 12$ washer(20)
cable hook(59) connect with double pulley plate(61)
3. Fix pulley(55) fastening on pint J using:
M10*45 hexagon bolt(52), $\Phi 10$ washer(5), M10 lock nut(23)
Put middle cable(62) at pulley(55) top position point O
4. Hang cable hook(59) on middle cable(62)

Assembly step (11) explosion drawing

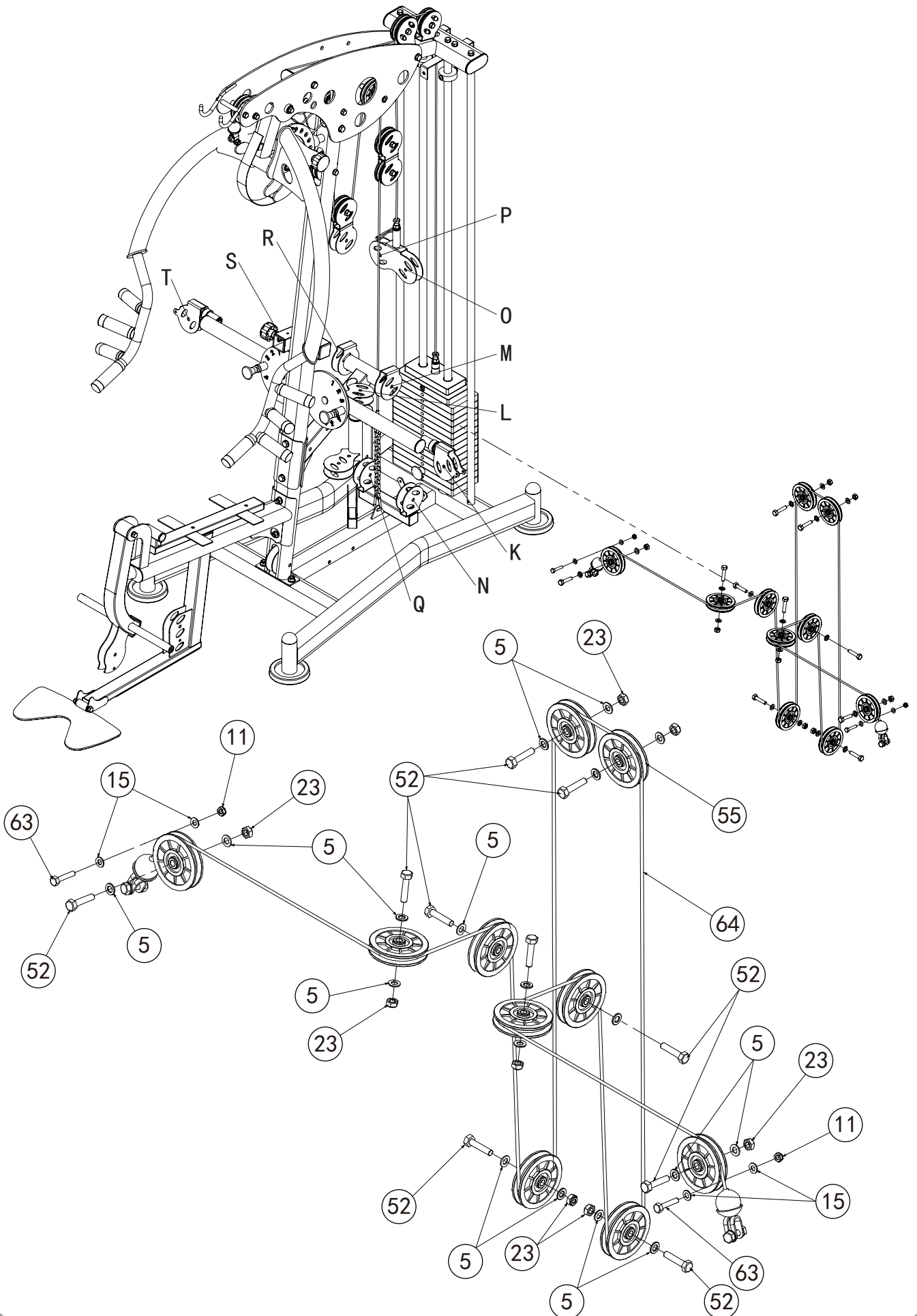

Assembly step (11) cable drawing

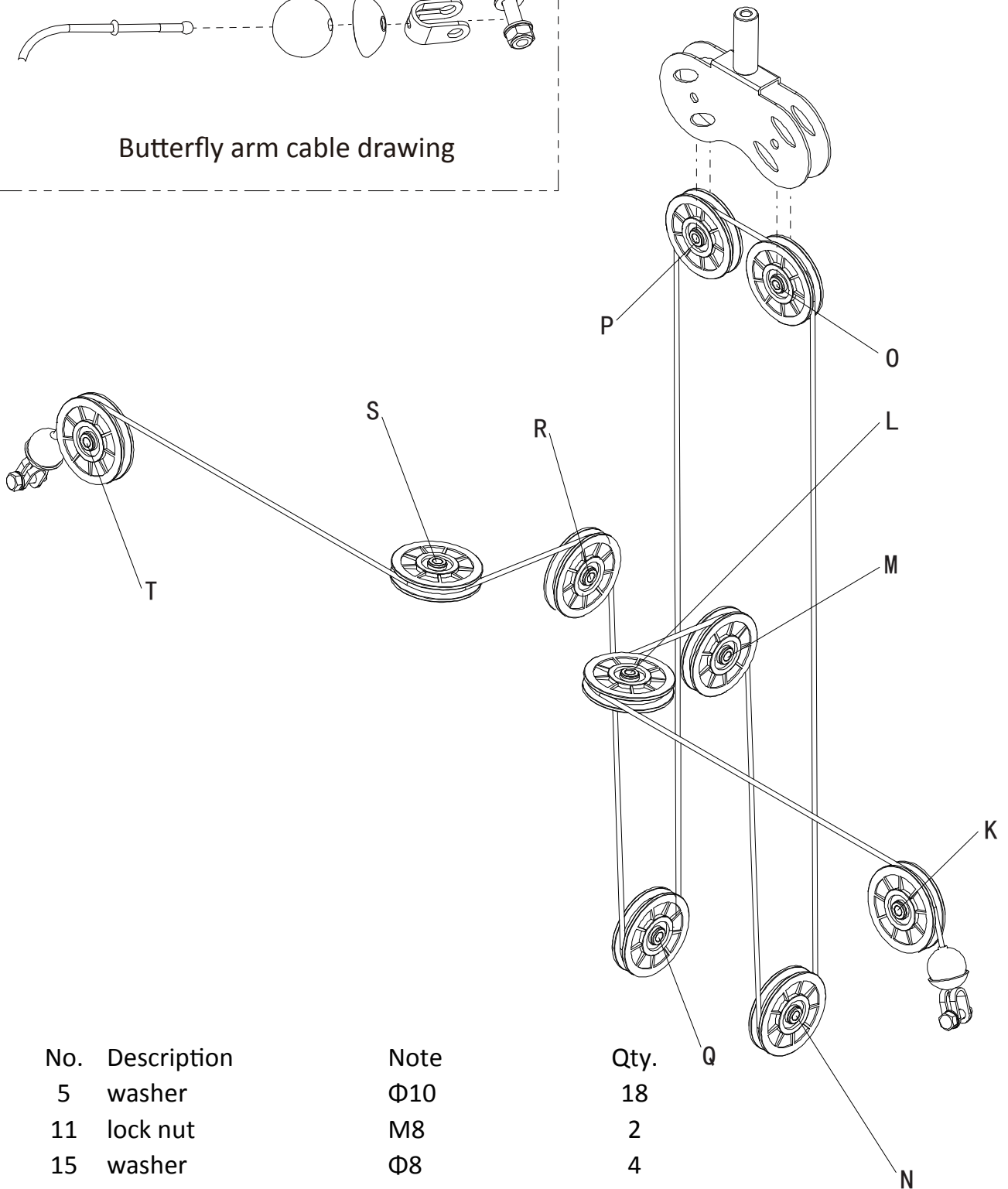
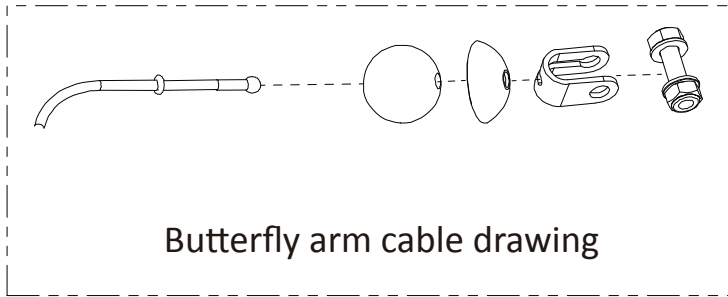

No.	Description	Note	Qty.
5	washer	Φ10	18
11	lock nut	M8	2
15	washer	Φ8	4
23	lock nut	M10	8
52	hexagon bolt	M10*45	10
55	pulley	Φ95*26	10
63	hexagon bolt	M8*45	2
64	butterfly arm cable	L:5375mm	1

Assembly step (11) drawing

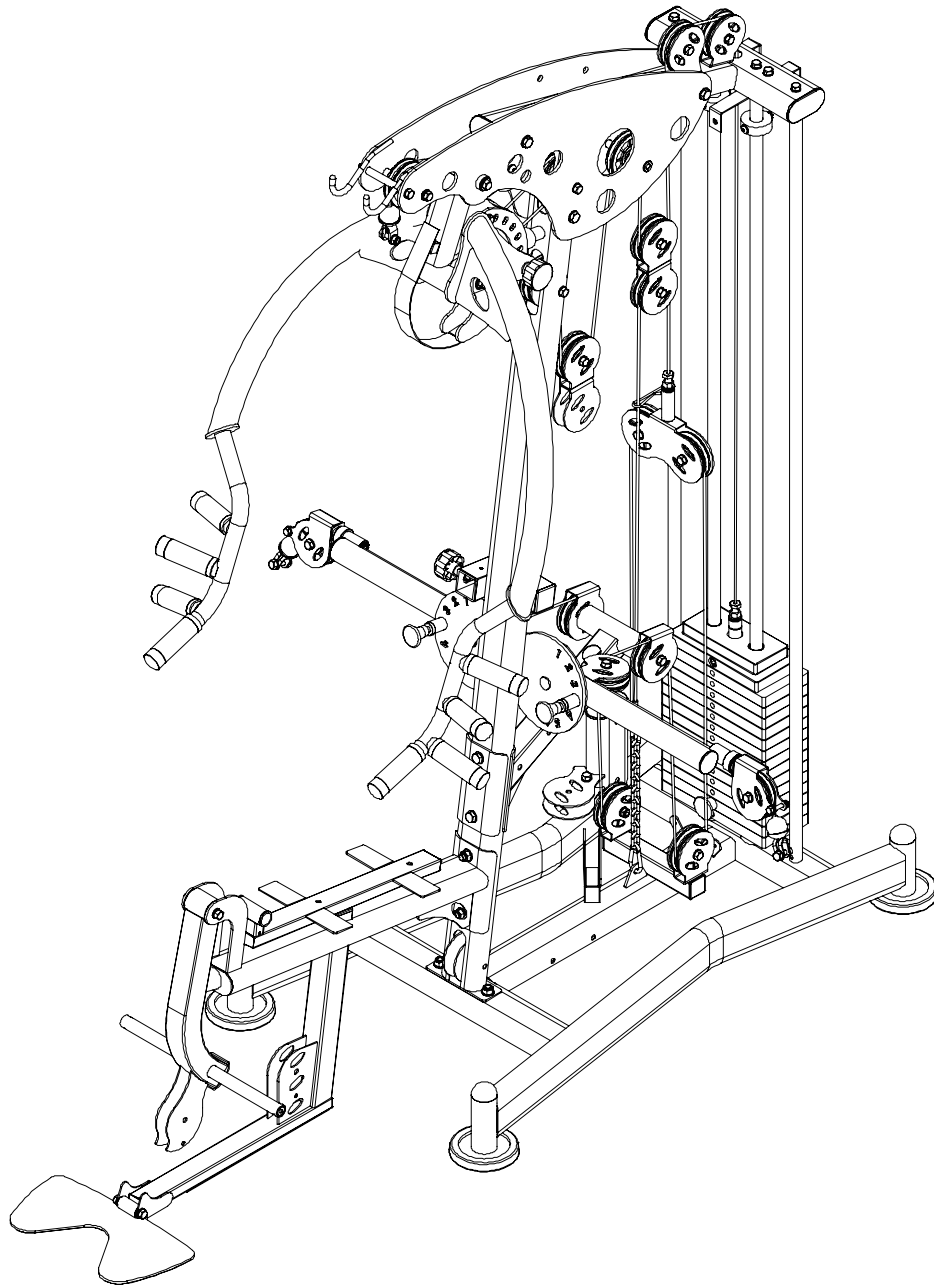

Assembly step (11) assembly instruction

1. Fix 8pcs pulley(55) fastening on pint: K,L,N,O,P,Q,R,S,T using: M10*45 hexagon bolt(52), Φ 10 washer(5),M10 lock nut(23)
2. Fix 2pcs pulley(55) fastening on pint: M,R using: M10*45 hexagon bolt(52), Φ 10 washer(5)
3. Take butterfly arm cable(64) end equipped ball head down
4. Butterfly arm cable(64)head down end from point P according through point: L,M,N,O,P,Q,R,S,T final installed ball head back to butterfly arm cable(64)
5. Installed M8*45 hexagon bolt(63), Φ 8 washer(15),M8 lock nut(11) near point: K,T

Assembly step (12) explosion drawing

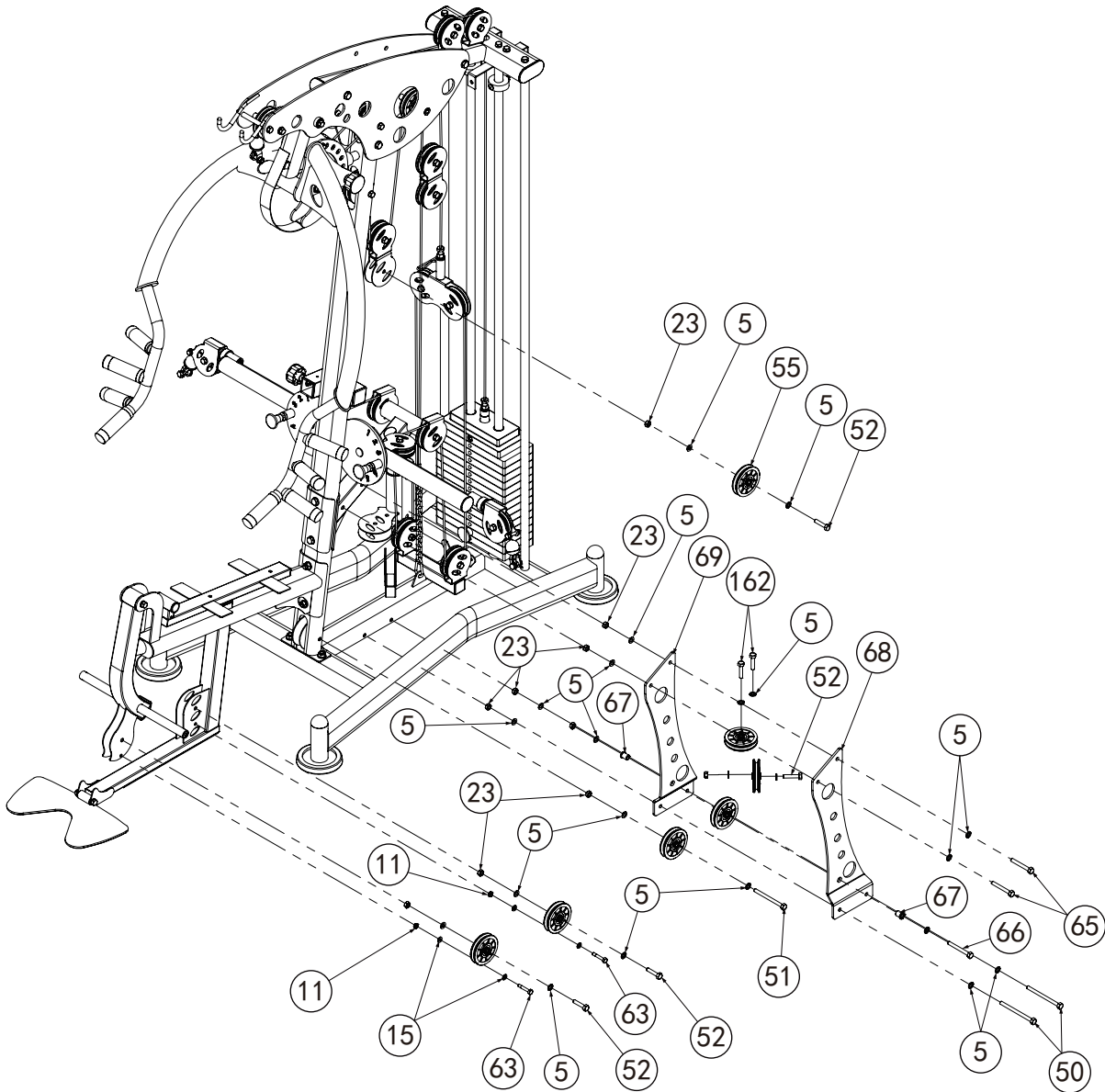

No.	Description	Note	Qty.
5	washer	Φ10	22
11	lock nut	M8	2
15	washer	Φ8	4
23	lock nut	M10	10
50	hexagon bolt	M10*130	2
51	hexagon bolt	M10*115	1
52	hexagon bolt	M10*45	4
55	pulley	Φ95*26	7
63	hexagon bolt	M8*45	2
65	hexagon bolt	M10*75	2
66	hexagon bolt	M10*85	1
67	powder metallurgy sleeve	Φ10	2
68	left support plate		1
69	right support plate		1
162	hexagon bolt	M10*40	2

Assembly step (12) drawing

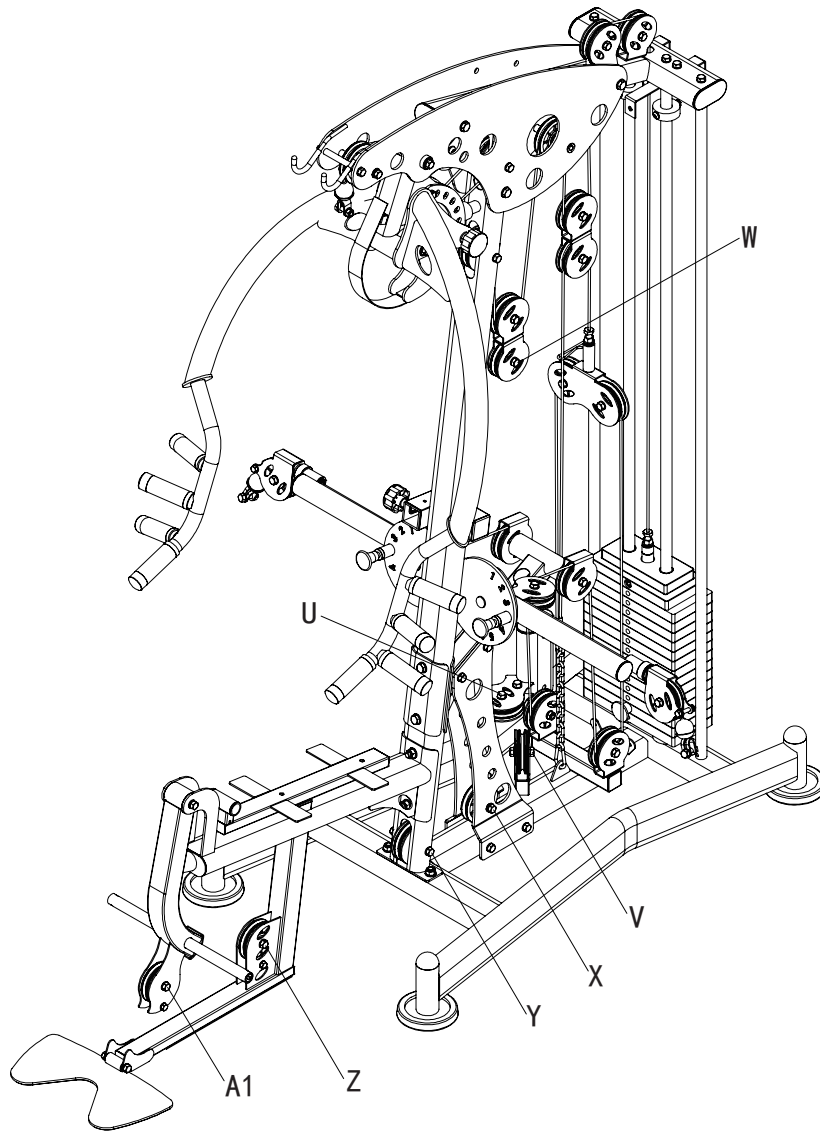

Assembly step (12) assembly instruction

1. Fix left support plate(68) & right support plate(69) fastening on ground frame and front frame using:
M10*130 hexagon bolt(50), M10*75 hexagon bolt(65), Φ 10 washer(5), M10 lock nut(23)
2. Fix 4pcs pulley(55) fastening on pint: V,W,Z,A1 using:
M10*45 hexagon bolt(52), Φ 10 washer(5), M10 lock nut(23)
3. Fix pulley(55) fastening on pint Y using:
M10*115 hexagon bolt(51), Φ 10 washer(5), M10 lock nut(23)
4. Fix pulley(55) fastening on pint X using:
M10*85 hexagon bolt(66), Φ 10 washer(5), powder metallurgy sleeve(67), M10 lock nut(23)
5. Fix pulley(55) fastening on pint U using:
M10*40 hexagon bolt(162), Φ 10 washer(5)
6. Installed M10*40 hexagon bolt(162), Φ 10 washer(5) near point: U
7. Installed M8*45 hexagon bolt(63), Φ 8 washer(15), M8 lock nut(11) near point: A1,Z

Assembly step (13) explosion drawing

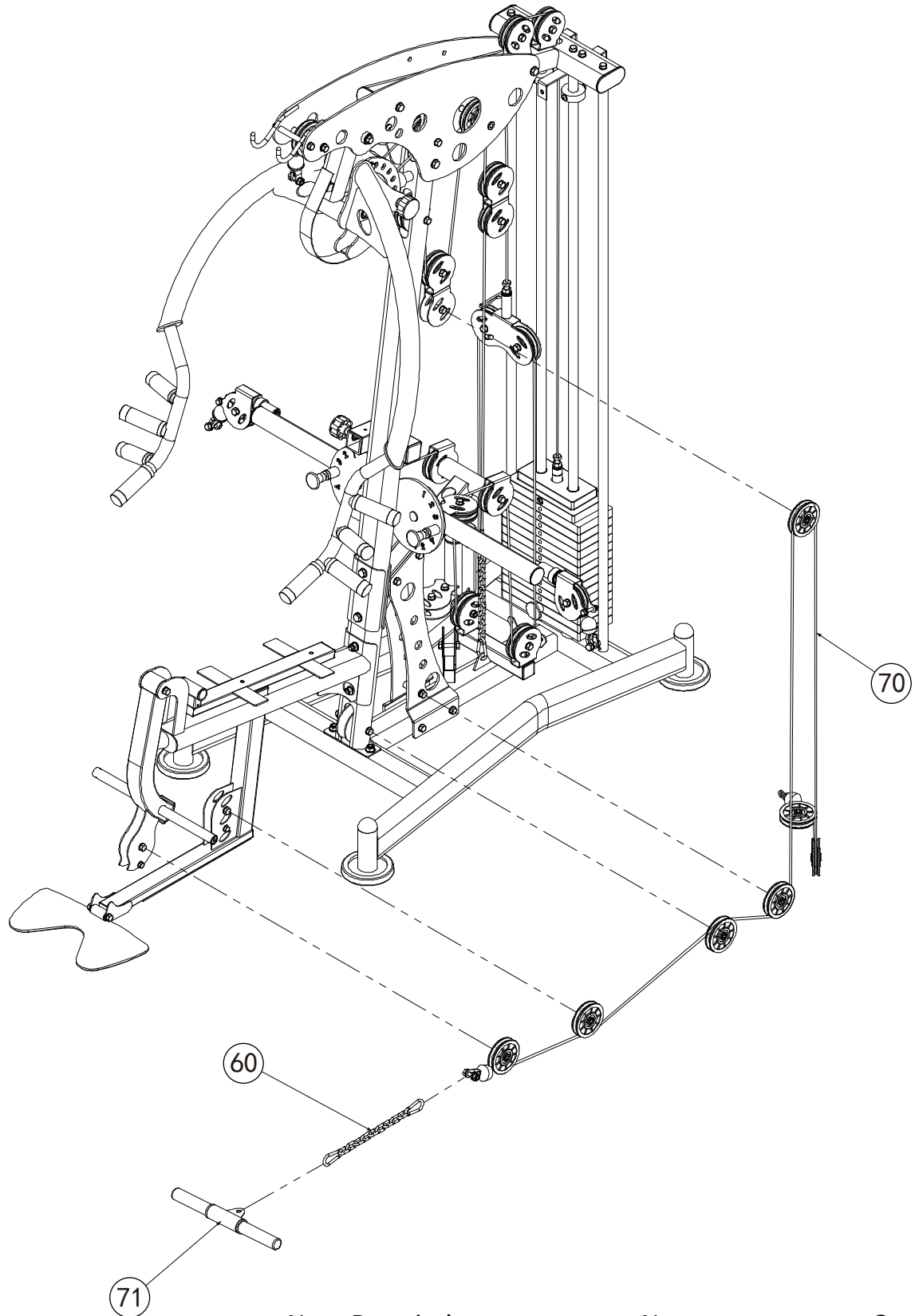

No.	Description	Note	Qty.
60	9 link chain & snap hook		1
70	low pull cable	L:4170mm	1
71	short bar		1

Assembly step (13) cable drawing

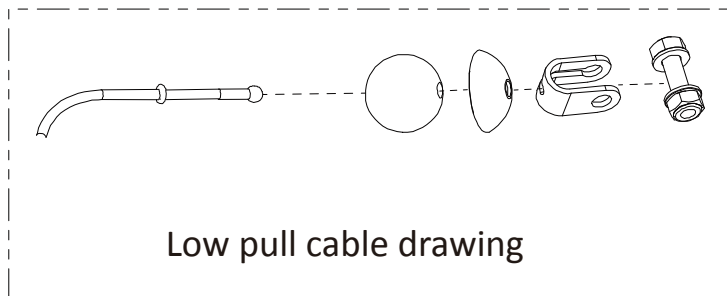
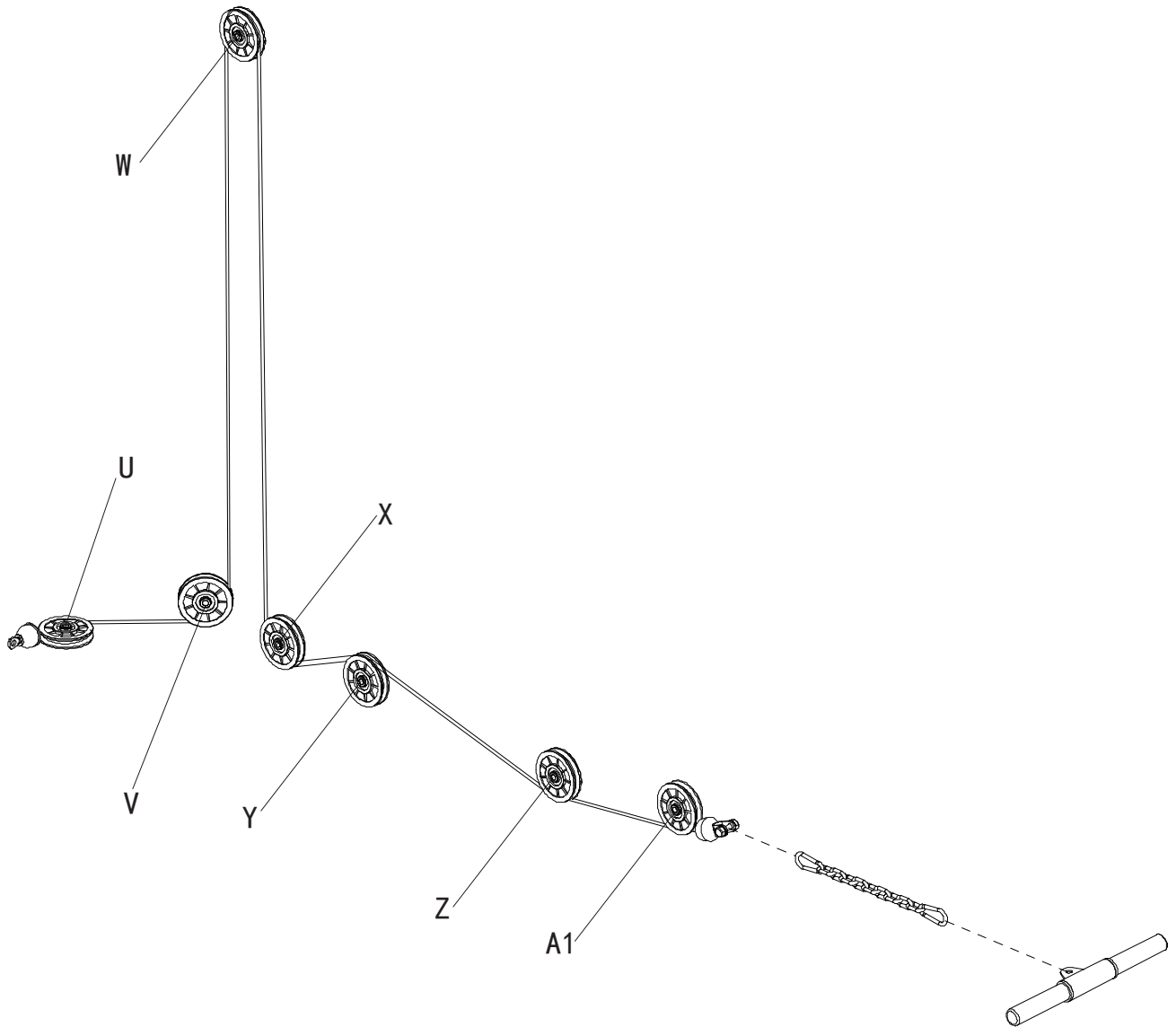

Assembly step (13) drawing

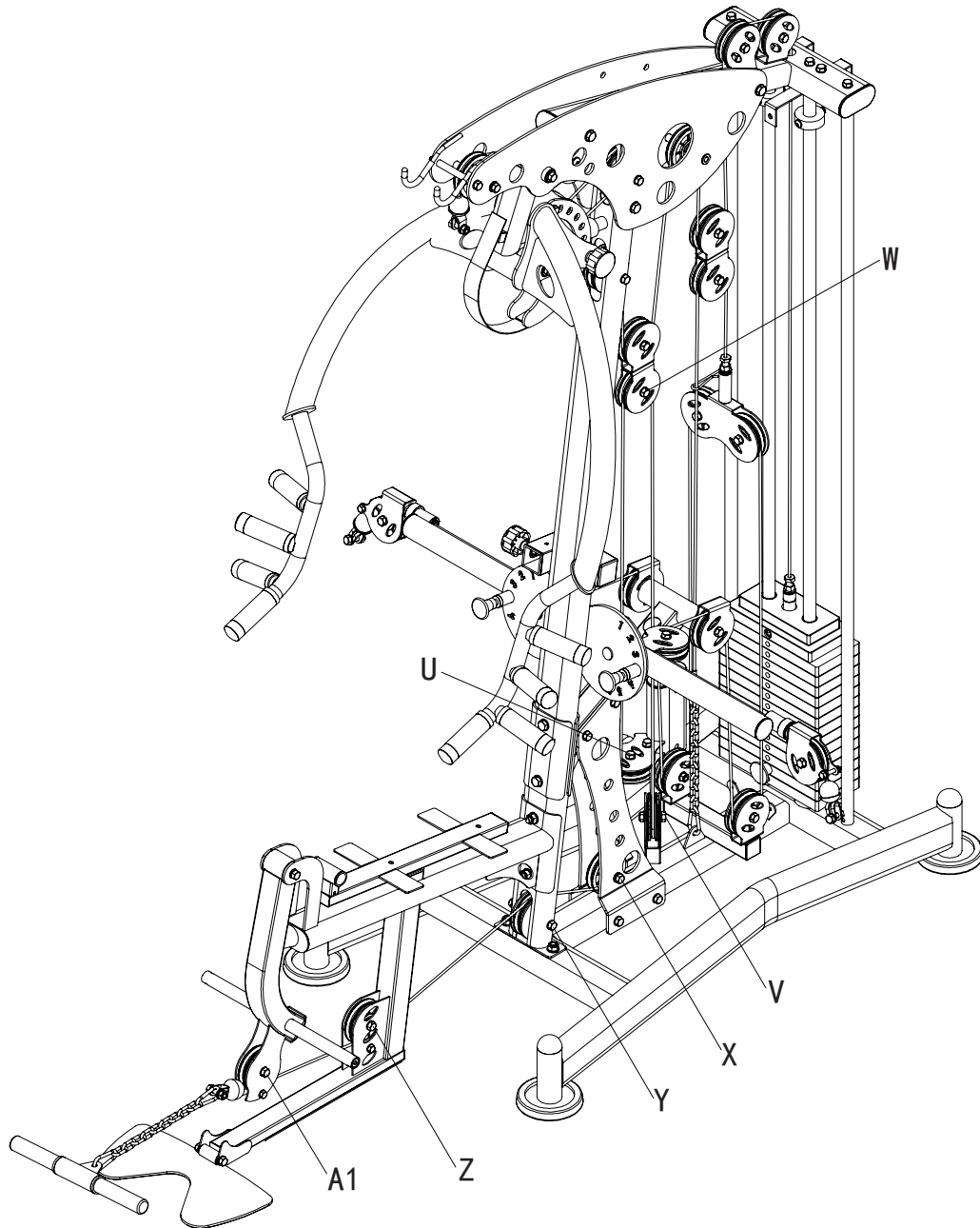

Assembly step (13) assembly instruction

1. Remove low pull cable(70) end equipped ball head down
2. Low pull cable(70)head down end from point U according through point: V,W,X,Y,Z,A1 final installed ball head back to cable
3. Connect 9 link chain & snap hook(60) with low pull cable(70), 9 link chain & snap hook(60) other end connect with short bar(71)

Assembly step (14) explosion drawing

No.	Description	Note	Qty.
15	washer	Φ8	5
72	spring washer	Φ8	4
73	hexagon bolt	M8*40	4
74	back cushion adjust frame		1
75	back cushion		1
76	seat cushion		1
150	hexagon bolt	M8*25	1

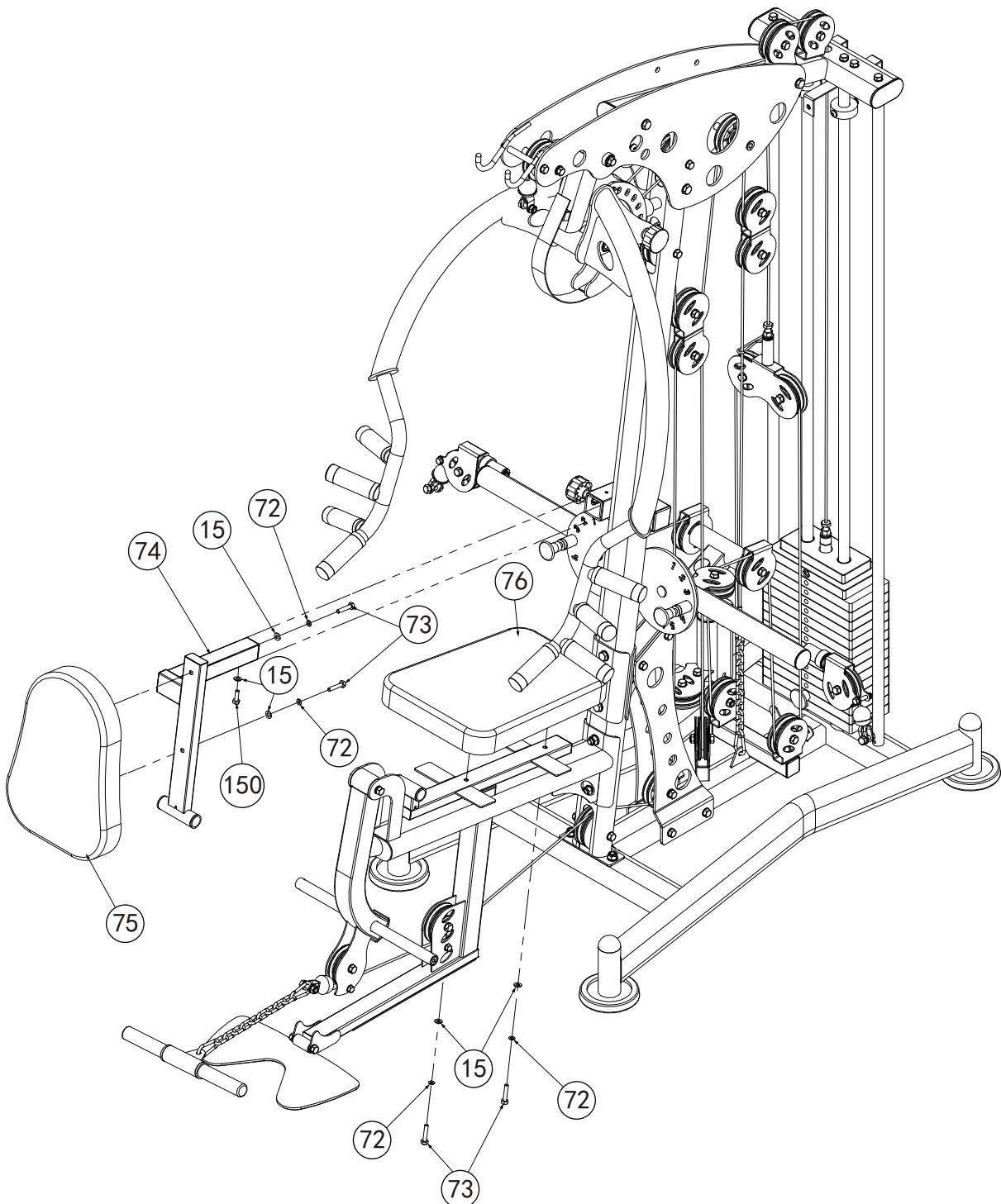

Assembly step (14) drawing

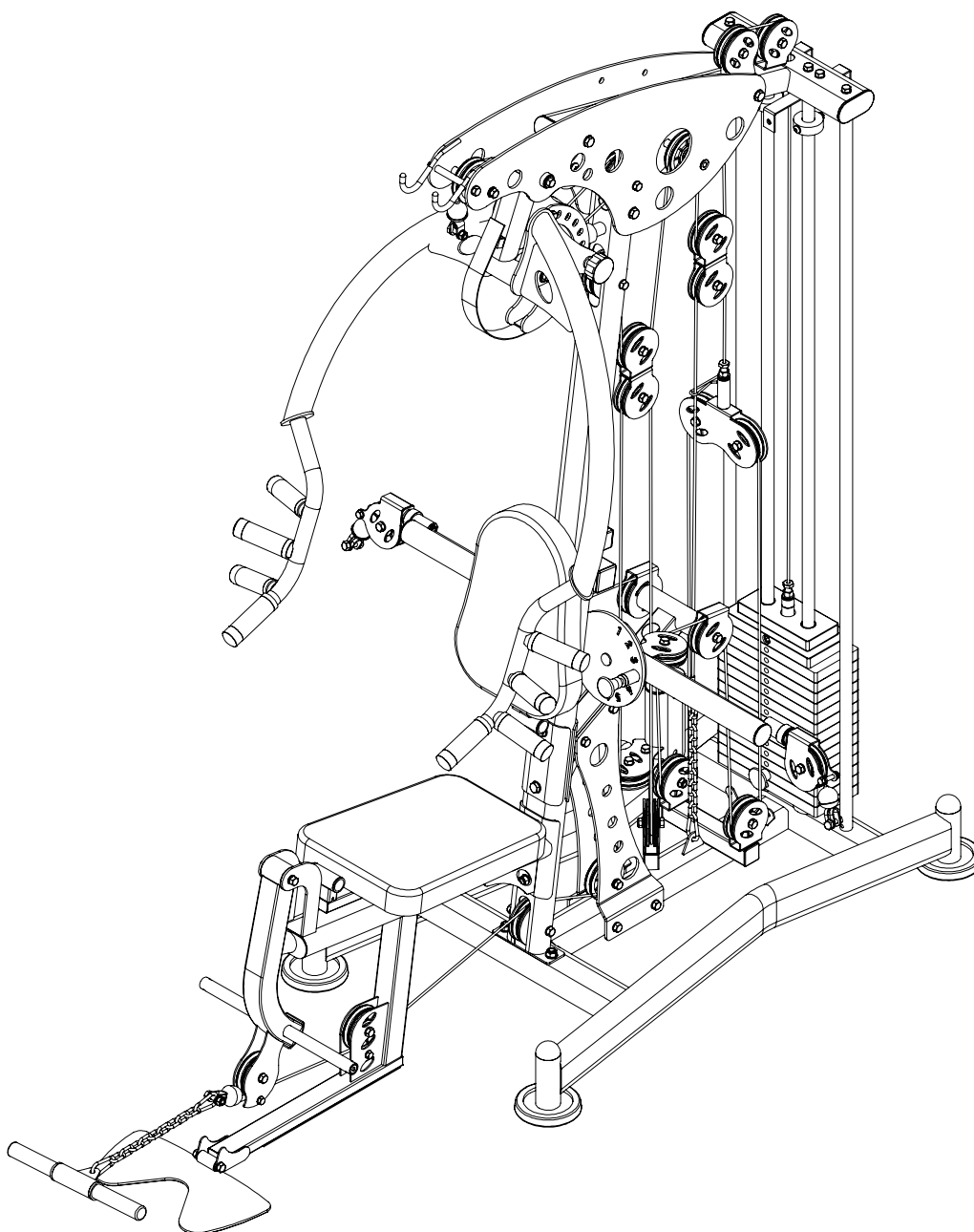

Assembly step (14) assembly instruction

1. Fix seat cushion(76) on seat cushion adjust frame using:
M8*40 hexagon bolt(73), Φ 8 spring washer(72), Φ 8 washer(15)
2. Fix back cushion(75) on back cushion adjust frame(74) using:
M8*40 hexagon bolt(73), Φ 8 spring washer(72), Φ 8 washer(15)
3. Push back cushion adjust frame(74) fastening into front frame using: pull pin
4. Fix back cushion adjust frame(74) on oblique support using:
M8*25 hexagon bolt(150), Φ 8 spring washer(15)

Assembly step (15) explosion drawing

No.	Description	Note	Qty.
77	hexagon socket button head bolt	M8*25	6
78	sponge inner cap		6
79	sponge outer cap		6
80	sponge	Φ100*175	6
81	sponge tube	Φ25*480	1
82	sponge tube	Φ25*450	1

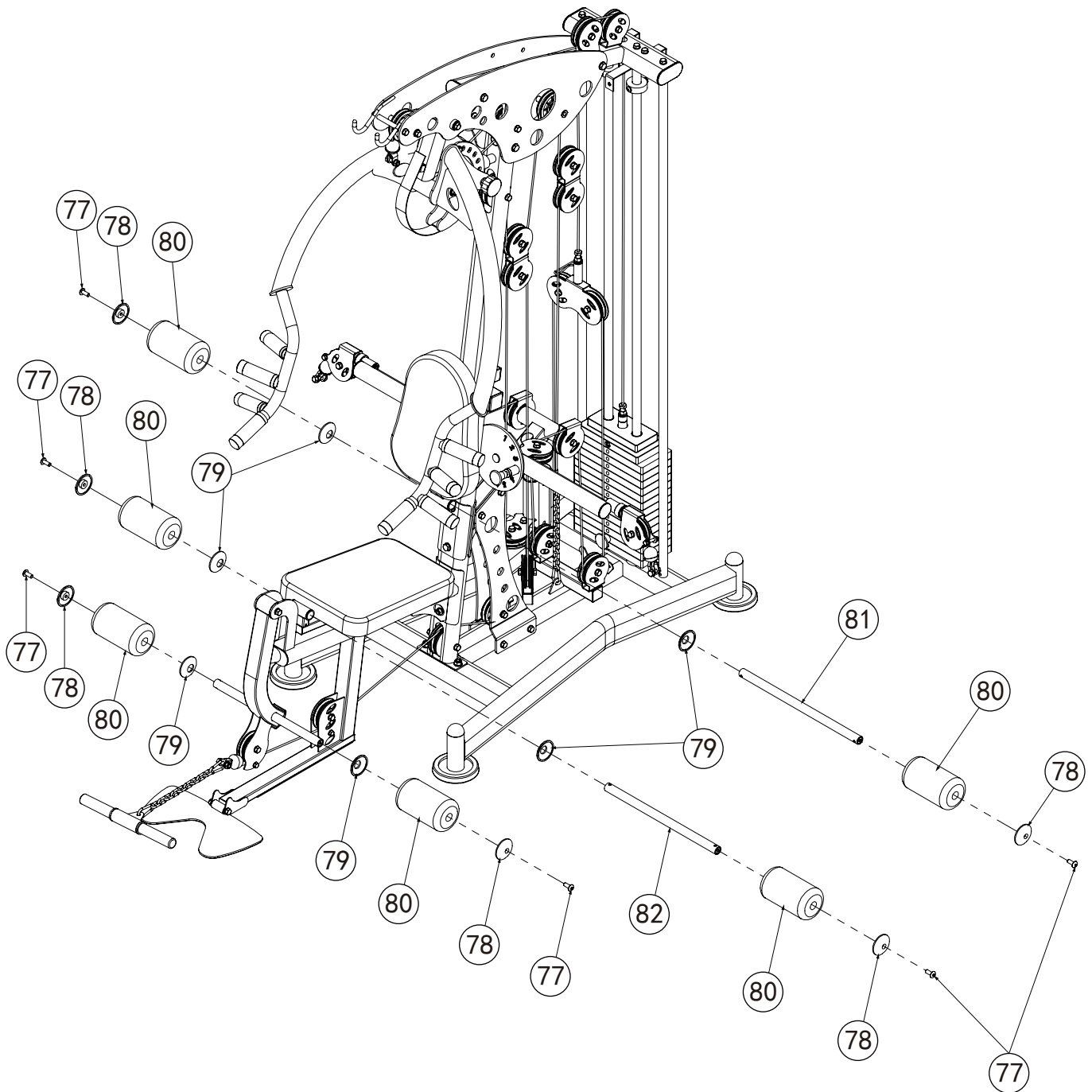

Assembly step (15) drawing

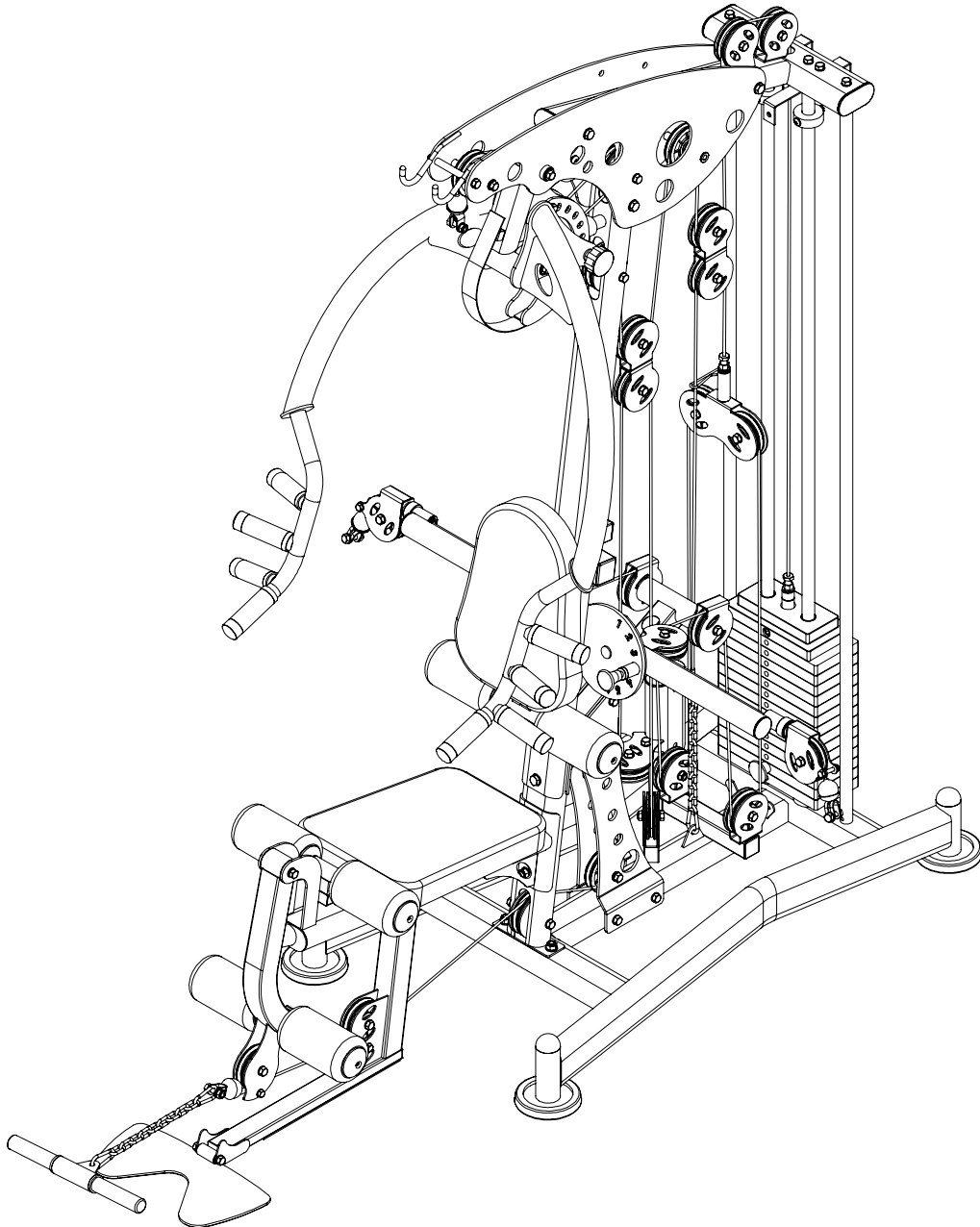

Assembly step (15) assembly instruction

1. Push sponge tube(81) into back cushion adjust frame, sponge tube(81) turn into:
sponge inner cap(79),sponge(80),sponge outer cap(78)
screw M8*25 hexagon socket button head bolt(77)
2. Push sponge tube(85) into seat cushion adjust frame, sponge pipe tube(85) turn into:
sponge inner cap(79),sponge(80),sponge outer cap(78)
screw M8*25 hexagon socket button head bolt(77)
3. Leg curl elbow tube turn into:
sponge inner cap(79),sponge(80),sponge outer cap(78)
screw M8*25 hexagon socket button head bolt(77)

Assembly step (16) explosion drawing

No.	Description	Note	Qty.
15	washer	Φ8	8
36	hexagon bolt	M8*16	8
72	spring washer	Φ8	8
83	shield		2

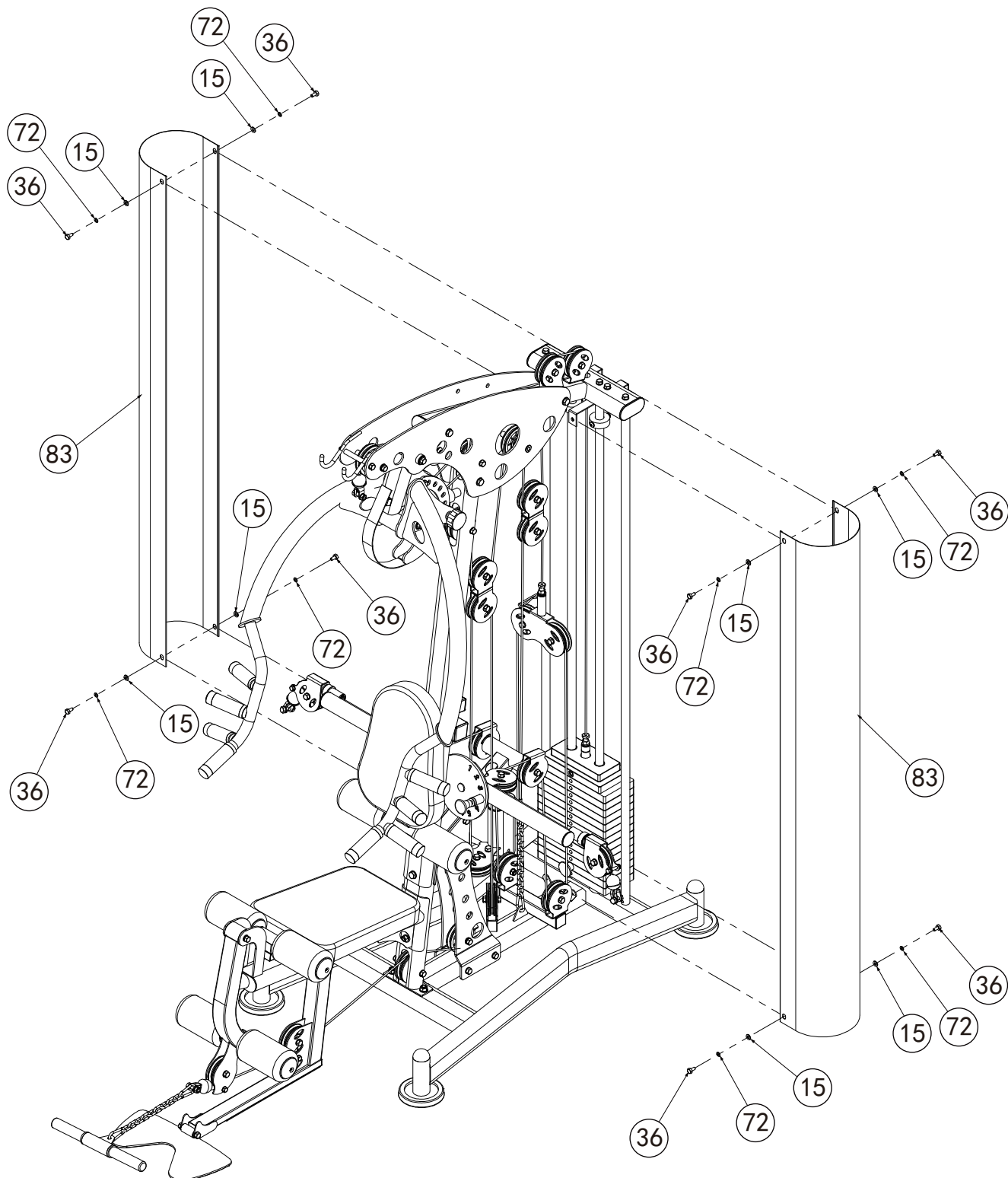

Assembly step (16) drawing

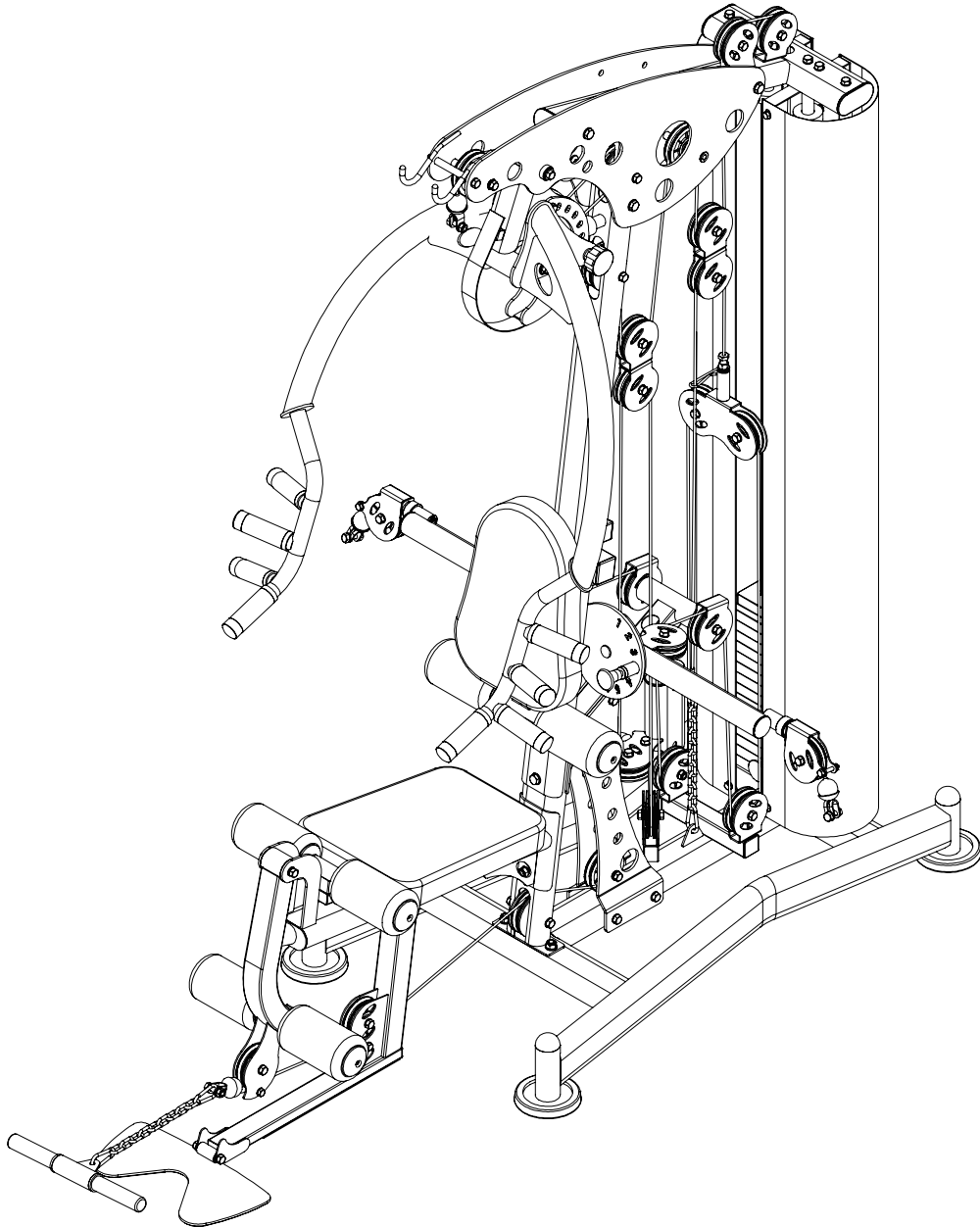

Assembly step (16) assembly instruction

1. Fix shield(83) on shield support frame and ground frame using:
M8*16 hexagon bolt(36)
Φ8 spring washer(72)
Φ8 washer(15)

Assembly step (17) explosion drawing

No.	Description	Note	Qty.
60	9 link chain & snap hook		3
84	long bar		1
85	handle belt		2

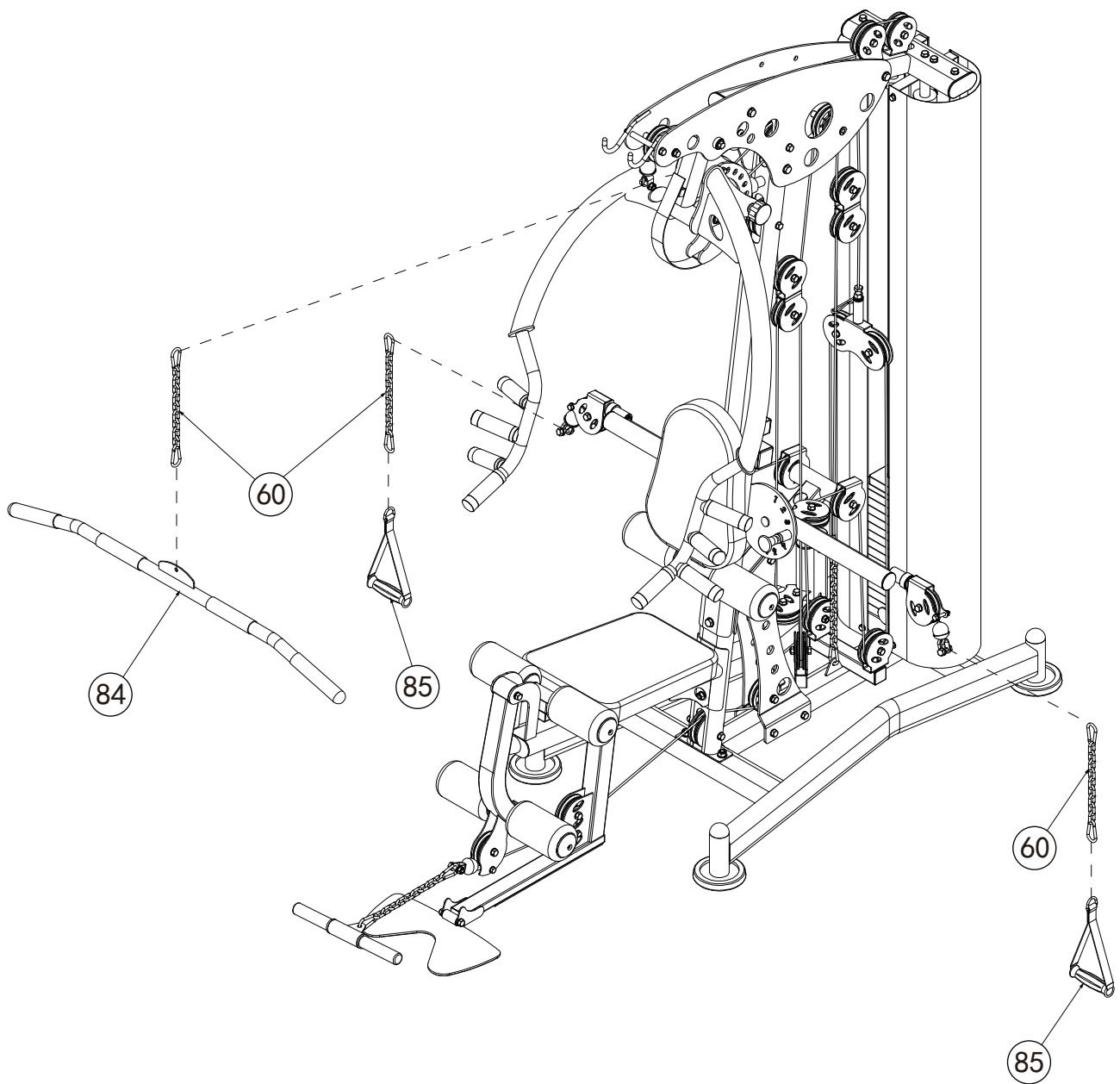

Assembly step (17) drawing

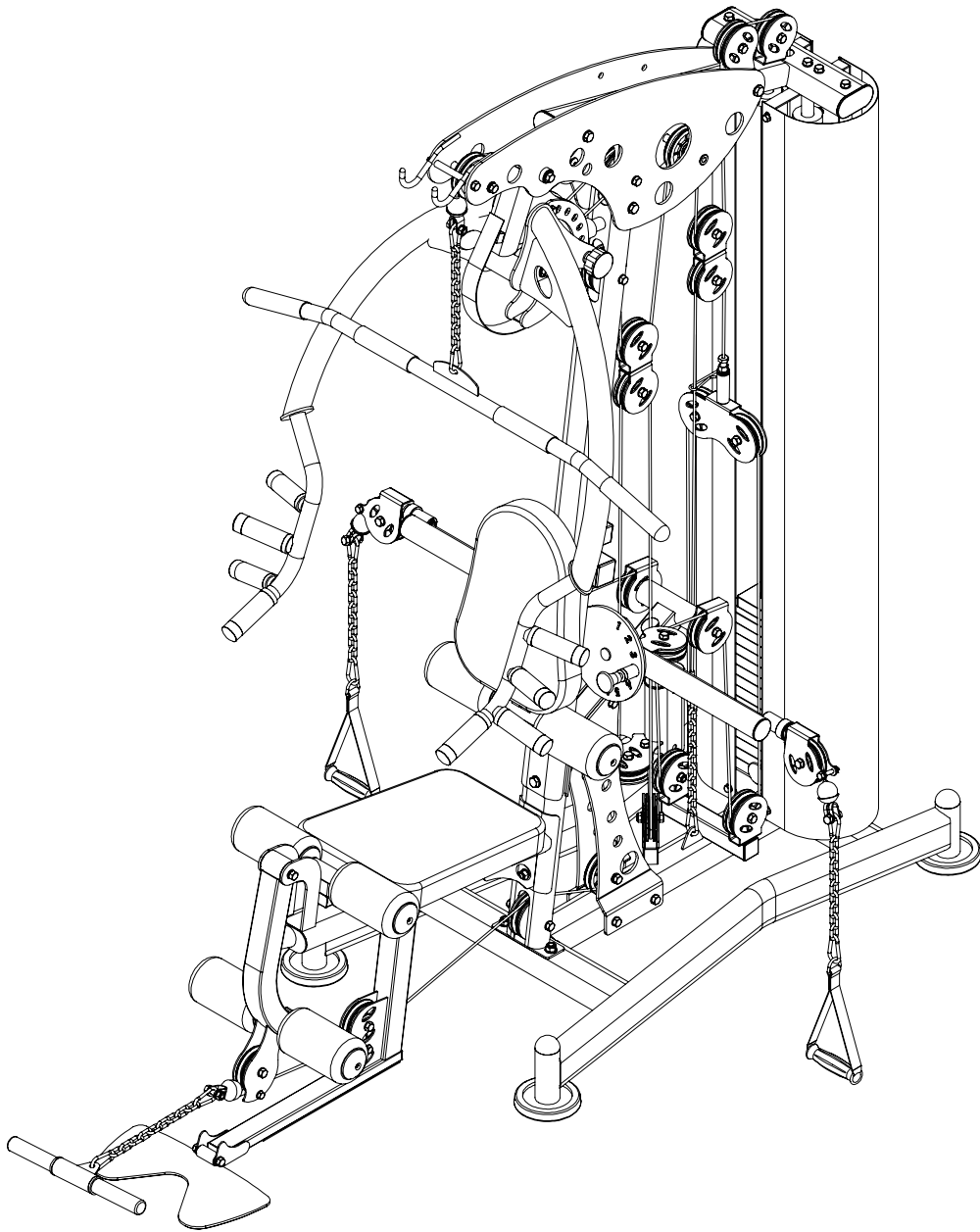

Assembly step (17) assembly instruction

1. Connect 9 link chain & snap hook(60)with handle belt(85),
9 link chain & snap hook(60)other end hang on butterfly arm cable ball head
2. Connect 9 link chain & snap hook(60) with long bar(85),
9 link chain & snap hook(60) other end hang on lat pull cable ball head

CAUTION: Please check machine all bolt, lock nut, pull pin whether tighten, tighten can use.



GARLANDO SPA
Via Regione Piemonte, 32 - Zona Industriale D1
15068 - Pozzolo Formigaro (AL) - Italy
contact@toorxprofessional.it
www.toorxprofessional.it