

DAFL50A

Scrubber dryer

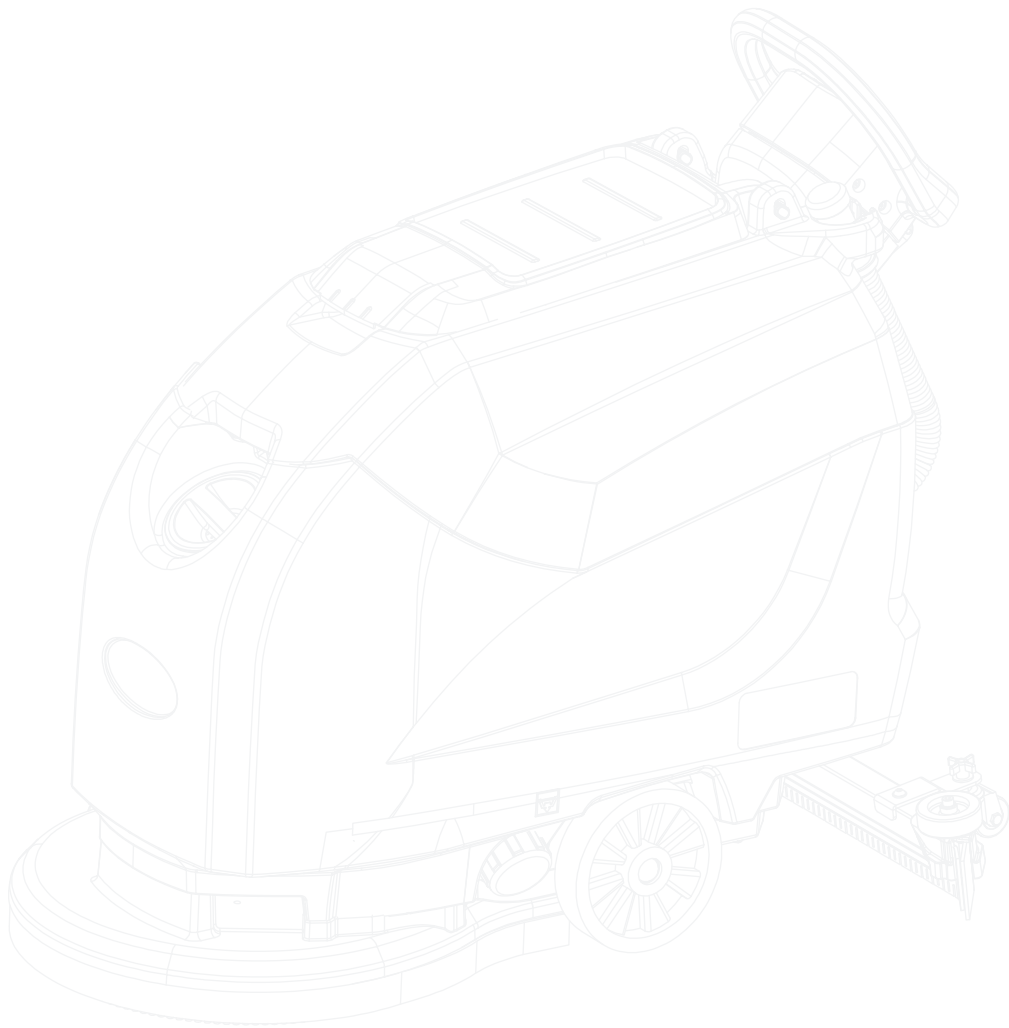

INDEX

1. SAFETY	3
2. SAFETY INSTRUCTIONS	5
3. FUNCTION	6
4. PROPER USE	6
5. OPERATING AND FUNCTIONAL ELEMENTS	7
6. OPERATOR CONSOLE	8
7. SYMBOLS ON THE MACHINE	8
8. BEFORE STARTUP	8
9. OPERATION	11
10. SHUTTING DOWN THE APPLIANCE	13
11. TRANSPORT	14
12. STORAGE	15
13. CARE AND MAINTENANCE	15
14. FROST PROTECTION	19
15. FAULTS	19
16. ACCESSORIES	20
17. TECHNICAL INFORMATION	21
18. EXPLODED VIEW AND SPARE PARTS LISTS	21
WARRANTY	29

The machine is intended for commercial use (e.g. in hotels, schools, hospitals, factories, shopping centers, offices, etc.).

Subject to the strict compliance with the instructions of use, these machines are used for the wet cleaning of hard flooring. These machines are exclusively designed for use in interior zones.

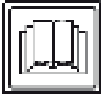

Always read the instructions of use and the safety instructions before using the machine for the first time.

The instructions of use must be kept in a safe and well accessible place so that you can refer to them at any time.



CAUTION:

This sign designates important information.

Failure to follow these instructions may result in danger to persons and/or extensive damage to property!



ATTENTION:

This sign designates important information. Failure to follow these instructions may result in faults and damage to property!



NOTICE:

This sign designates important information regarding the efficient use of the product. Failure to follow these instructions may result in faults!



ATTENTION:

The machine must not be used for polishing, oiling, the application of wax, carpet cleaning or dust removal. The wet cleaning of parquet and laminate flooring with this machine is at your own risk.



CAUTION:

Changes to the machine that have not been authorized by Diversey will lead to the expiry of safety marks and CE conformity. Using the machine for purposes other than the intended purpose can cause injuries to persons, and damage to the machine and the working environment. Such cases will usually result in the termination of any warranty and possible guarantee claims.



CAUTION:

The machine may only be used by persons who are adequately trained for the use of the machine or who have provided proof of their skills regarding the use of the machine and who are explicitly commissioned to use the machine.



CAUTION:

The machine must not be used by people with reduced physical, sensory or mental capacities, including children or people who lack experience or knowledge. Children must be supervised to ensure that they do not play with the machine.



CAUTION:

Do not use the machine in rooms where explosive or highly combustible substances (e.g. gas, solvents, heating fuel, dust, etc.) are stored or processed.
These substances electrical or mechanical components of the machine.



CAUTION:

Do not use the machine for the vacuum cleaning of poisonous, harmful, caustic or irritating substances (e.g. dangerous dust, etc.). The filter system does not adequately filter out these kinds of substances.
Possible impacts on the health of the user or third persons cannot be ruled out.



CAUTION:

Pay attention to the local situation as well as to third persons and children! In the vicinity of blind spots such as doors or curves in particular, it is important to reduce speed.



CAUTION:

Do not transport other persons and objects with this machine.



CAUTION:

In case of malfunction or defector after collisions or toppling over, the machine must be inspected by an authorized expert before restarting. The same applies if the machine was left outdoors, immersed in water or subjected to moisture.



CAUTION:

The machine must be stopped immediately in case of damage to safety relevant parts such as brush covers, main cords or covers that enable access to live parts.



CAUTION:

The machine must not be stopped, parked or stored on slopes.



CAUTION:

The machine must be switched off for any work carried out on the machine.



CAUTION:

Do not use the machine in rooms with high electromagnetic interference (electric smog).



CAUTION:

The machine must not be used on slopes >2%.
Sharp cornering on slopes can affect the stability of the machine and is therefore prohibited.
Danger of accident.



ATTENTION:

The machine must be protected against unauthorized use. Therefore, keep the machine in a locked room before leaving it.



ATTENTION:

Operate and keep the machine in a dry and low dust environmental temperatures between +10 and +35 degrees only.



ATTENTION:

Only authorized experts who are familiar with all safety instructions relevant for this machine are allowed to repair mechanical or electrical machine parts.



ATTENTION:

Only tools (brushes, pads or similar) that are specified in these instructions of use under accessories, may be used. Any other brushes might impair the safety and functions of the machine.



ATTENTION:

National regulations for personal protection and accident prevention as well as the manufacturer's instructions for the use of cleaning solutions must be consistently observed.



ATTENTION:

It is forbidden to plug in or unplug the main power supply cord with wet hands!



ATTENTION:

Make sure that the rated voltage stated on the machine label is the same as the voltage rating of the plug socket!



ATTENTION:

Take care not to damage the power supply cord by rotating tools (brushes, pads or similar), crimping, tearing or damaging the power supply cord through heat, oil, or sharp objects!



ATTENTION:

In case of foam or liquid leakage from the machine, the suction unit must be switched off immediately.

Further documents



ATTENTION:

DAEWOO machines and devices are designed such that health risks caused by noise emissions or vibrations can be ruled out according to the current state of science.

Before using the appliance for the first time, read and observe these operating instructions and the accompanying brochure: Safety information for brush cleaning units and spray-extraction units, No. 5.956-251.0.

The device may only be operated when the cover and all lids are closed. The appliance must only be operated on surfaces that do not exceed the max. permitted incline (see "Technical Specifications").

WARNING

Do not use the appliance on inclines.

Safety devices

Safety devices serve to protect the user and must not be rendered inoperational or their functions bypassed.

Safety switch

If the safety switch is released, the brush drive shuts off.

Danger or hazard levels

DANGER

For an immediate danger which can lead to severe injuries or death.

WARNING

For a possibly dangerous situation which could lead to severe injuries or death.

CAUTION

Pointer to a possibly dangerous situation, which can lead to minor injuries.

ATTENTION

Pointer to a possibly dangerous situation, which can lead to property damage.

The scrubbing vacuum cleaner is used for the wet cleaning of level floors.

– The device can be easily adjusted to the respective cleaning task by adjusting the water volume and the detergent volume.

The detergent dosing unit can be adjusted via the addition in the tank.

– The device is equipped with a fresh water and a waste water tank (50 litres each). These allow an effective cleaning with a long usage life.

– A working distance of 500 mm will improve the efficiency when you are using the appliance for a long period.

– Propulsion is accomplished by manually pushing the appliance and is supported by the rotation of the brushes. The brush drive is powered by two batteries.

– The extendible transport chassis ensures easy transport runs.

– Batteries can be selected depending on the configuration (refer to Chapter "recommended batteries")

NOTE:

The appliance can be equipped with various accessories depending on the cleaning task.

Please request our catalogue or visit us on the Internet.

Use this appliance only as directed in these operating instructions.

– The appliance may only be used for the cleaning of hard surfaces that are not sensitive to moisture and polishing operations.

– The appliance is not suited for the cleaning of frozen grounds (e.g. in cold stores).

– The appliance may only be equipped with original accessories and spare parts.

– The appliance is not suited for the use in potentially explosive environments.

– The machine should not be used to suck in inflammable gases, undiluted acids or solvents.

This includes petrol, thinning agents or hot oil that can form an explosive mixture when it comes in contact with sucked air. Do not use acetone, undiluted acids and solvents as they are aggressive towards the materials from which the appliance is made.

– The machine has been approved for use on surfaces with max. gradients as listed under "Technical specifications".

– This appliance is suited for the commercial use, e.g. in hotels, schools, hospitals, factories, shops, offices, and rental companies.



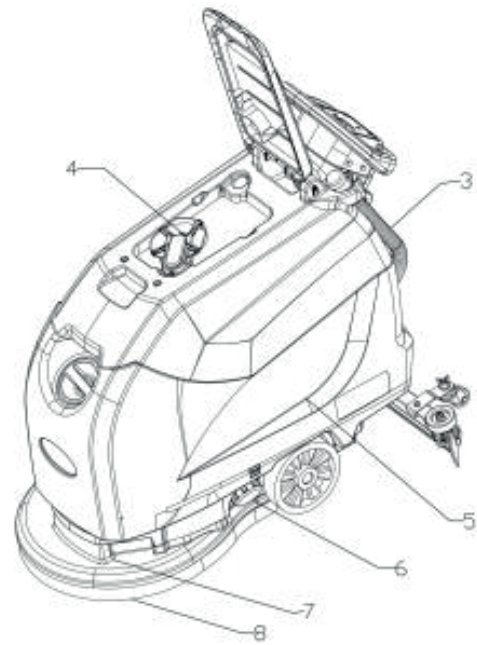
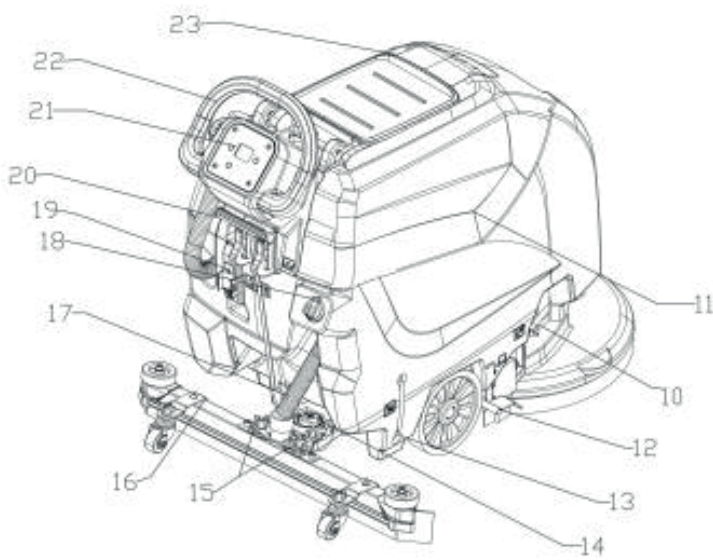
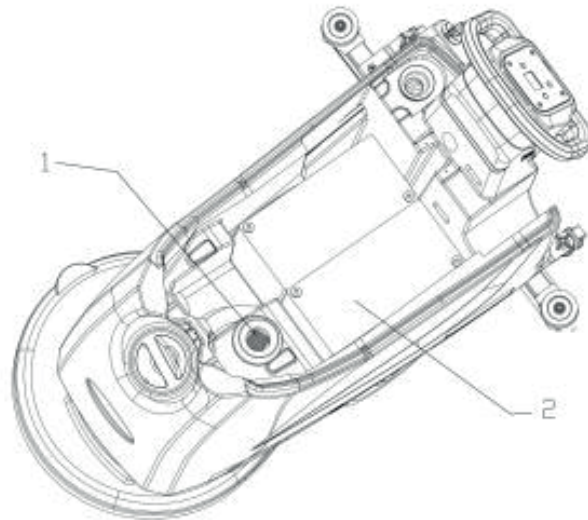







– The appliance was designed for the cleaning of floors inside or of covered surfaces.



- 1 Fluff filter
- 2 Battery
- 3 Drain hose for waste water
- 4 Holding rail for home base
- 5 Fresh water tank
- 6 Fresh water tank lock
- 7 Cleaning head
- 8 Disc brush
- 9 Fresh water reservoir filler neck
- 10 Bow brush change
- 11 waste water tank
- 12 Pedal transport chassis
- 13 Fresh water level display
- 14 Rotary handle to incline the vacuum bar
- 15 nuts for fastening the vacuum bar
- 16 Vacuum bar
- 17 Suction hose
- 18 Water quantity regulator
- 19 Battery socket
- 20 Vacuum bar lowering lever
- 21 Operator console
- 22 Push handle
- 23 Cover waste water tank



- 1 Display
- 2 Brush mode
- 3 Vacuum mode
- 4 Eco mode
- 5 Key

-   Battery socket
-  Lashing point
-  Mop holder **
-  Filling level fresh water tank 25%
-  Bow brush change
-  Vacuum bar lowering lever
-  Pedal transport chassis
-  Drain outlet fresh water tank
-  Dirt water discharge hose

** option

Unloading

- Unscrew the screws from the middle board of the pallet.
- Push down the device holding the push handle and pull out the middle board.
- Remove the chocks in front of and next to the wheels.
- Push down the device holding the push handle and push it forwards up to the edge of the pallet.
- Lift the device off the pallet and set it on the floor.

Install batteries

Install the batteries (see "Care and Maintenance/Install and connect batteries").

Using batteries made by other manufacturers

We recommend using our batteries as described in chapter "Care and Maintenance/ Recommended batteries".

Charging battery

NOTE:

The device is equipped with a safety mechanism to prevent total discharge, i.e. when the permissible minimum capacity is reached, the brush motor and the turbine are switched off.

- Drive the machine directly to the charging station; avoid any steep gradients in the process.

DANGER

Danger of injury due to electric shock. Observe the mains voltage and fuse protection on the type plate of the device.

Charging process

Average charging time is approx. 10 -15 hours.

The appliance must not be used during the charging process.

DANGER

Danger of explosion

Prior to charging low-maintenance batteries

Remove waste water tank (see Chapter "Maintenance and care/Maintenance tasks/Removing the waste water tank"). This prevents the accumulation of hazardous gases underneath the tank during the charging process.

ATTENTION

Risk of damage. Do not clean the device with water while the tank is removed.

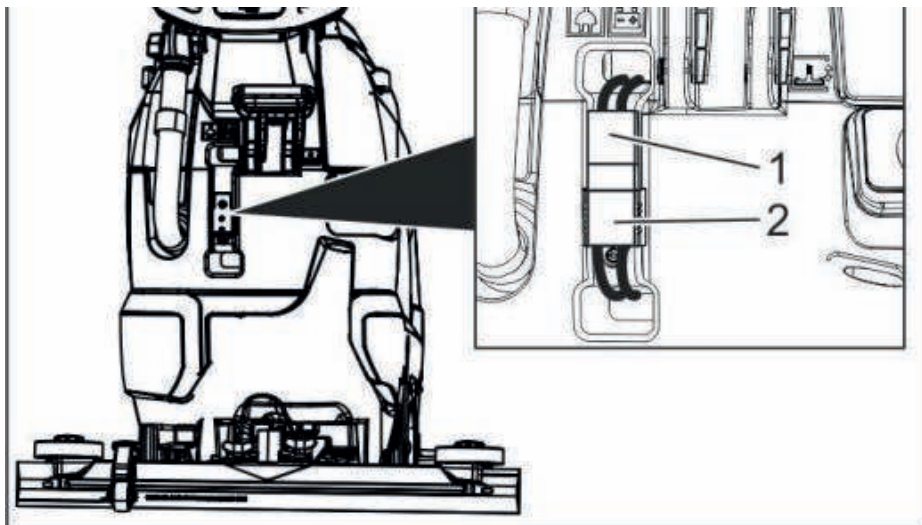

1 Battery plug, appliance side

2 Battery plug, battery side

- Detach the battery plug on the unit side.

ATTENTION

Risk of damage!

- Do not connect the charger with the battery plug on the unit side.
- Only use a charger that is suitable for the installed battery type:

NOTE: Please read the operating instructions of the charger manufacturer, especially the chapters on safety instructions!

- Connect the battery plug on the battery side with the charger.
- Plug the mains plug of the charger into a power outlet.
- Execute the charging process according to the information in the operating instructions of the charger.
- Connect the battery plug on the device side with the battery plug on the battery side.

Low maintenance batteries (wet batteries)

WARNING

Danger of causticization!

- Adding water to the battery in its discharged state can cause the acid to leak.
- Use safety glasses while handling battery acid and follow the safety instructions to avoid personal injury or damage to clothes.
- Should the acid spray on to the skin or clothes, rinse immediately with lots of water.

ATTENTION

Risk of damage!

- Use only distilled or desalinated water (EN 50272-T3) for filling the battery.
- Do not add any substances (so-called performance improving agents), else warranty claims will not be entertained.
- Replace batteries with the same battery type only.

Installing the Vacuum Bar

- Insert the vacuum bar into the vacuum bar suspension in such a manner that the profiled sheet is positioned above the suspension.
- Tighten the nuts.

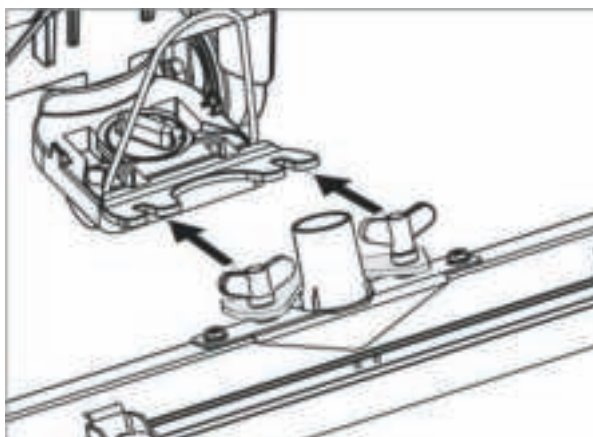

- Insert the suction hose.

DANGER

Risk of injury!

In dangerous situations, release the safety switch/drive lever.

Filling in detergents

- Fresh water

- Open the lock of the fresh water reservoir.
- Fill fresh water (maximum 60 °C) until the lower edge of the filling nozzle.
- Close the lock of the fresh water reservoir.

- Detergent

WARNING

Risk of damage. Only use the recommended detergents. With other detergents, the operator bears the increased risk regarding the operational safety and danger of accident.

Only use detergents that are free from solvents, hydrochloric acid and hydrofluoric acid.

Follow the safety instructions for using detergents.

NOTE: Do not use highly foaming detergents.

Recommended detergents:

Application	Detergent
Routine cleaning of all water resistant floors	RM 746 RM 780
Routine cleaning of glossy surfaces (e.g. granite)	RM 755 es
Routine cleaning and basic cleaning of industrial floors	RM 69 ASF
Routine cleaning and basic cleaning of fine stoneware tiles	RM 753
Routine cleaning of tiles in sanitary areas	RM 751
Cleaning and disinfection in sanitary areas	RM 732
Removal of coating from all alkali-resistant floors (e.g. PVC)	RM 752
Removal of coating from linoleum floors	RM 754

- Add the detergent to the fresh water reservoir.

NOTE:

If the fresh water tank is empty, the cleaning head continues working without liquid supply.

Setting the water quantity

- Adjust the water quantity using the regulating button according to the dirt on the floor covering.

NOTE: Carry out initial cleaning attempts with low water volume. Increase water volume step-by-step until the desired cleaning result is achieved.

Setting the Vacuum Bar

Oblique position

To improve the vacuuming result on tiled floors the vacuum bar can be turned to an oblique position of up to 5°.

- Loosen the nuts.
- Turn the vacuum bar.

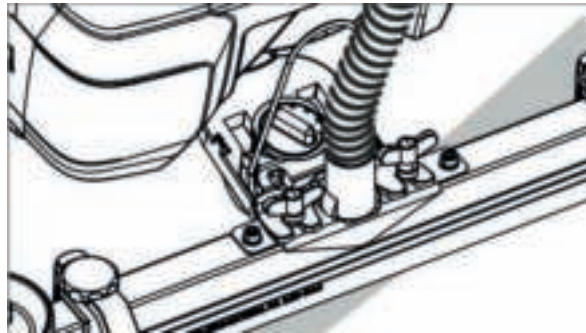

- Tighten the screws.

Inclination

If the vacuum result is unsatisfactory the inclination of the straight vacuum bar can be modified.

- Adjust the rotary handle to incline the suction bar.

Transport chassis

The transport chassis lifts the cleaning head off the floor.

Transport runs are performed with the cleaning head raised or dirt is vacuumed up.

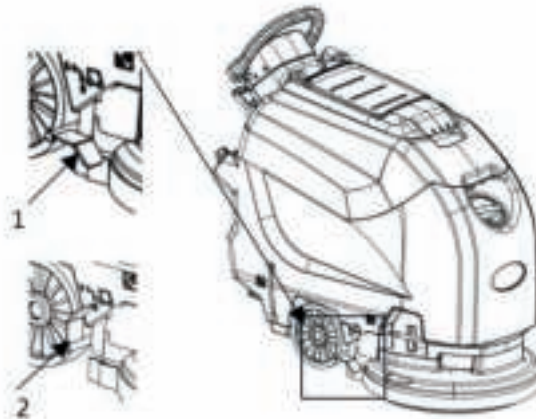

1 Transport chassis pedal in transport position

2 Transport chassis pedal in cleaning position

- Using your foot, move the transport chassis pedal to the required position.

Cleaning

ATTENTION

Risk of damage to the floor covering. Do not operate the appliance on the spot.

- Swivel the transport chassis to the cleaning position.
- Turn the program selection switch to the desired cleaning program.

Lower the vacuum bar

- Pull the lever out and press it down; the vacuum bar is lowered.

NOTE:

– For cleaning tiled floors, adjust the straight suction bar in such a way that cleaning is not done at an angle of 90 degrees to the joints.

– The inclined position and the inclination of the suction bar can be adjusted to achieve better suction results (see "Adjusting the suction bar").

– If the waste water tank is full, the float closes the suction opening and the suction turbine runs at an increased speed.

If this is the case, shut the vacuum off and drive to empty the waste water tank.

- Close the regulatory button for setting the water quantity.
- Release the safety switch.
- Set the program selection switch to suction or vacuuming.
- Briefly drive forward and suck of the remaining water.
- Raise the vacuum bar.
- Swivel the transport chassis to the transport position.
- Charge battery, if required.

Drain off dirt water

WARNING

Please observe the local provisions regarding the wastewater treatment.

- Take the water discharge hose from the support and lower above a suited collection device.

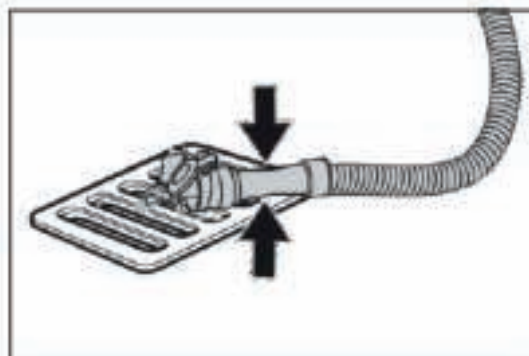

- Open the lid of the dosing equipment.
- Drain off the dirt water - regulate the water quantity by pressing or bending.
- Rinse the waste water tank with clear water.

Drain off cleanwater

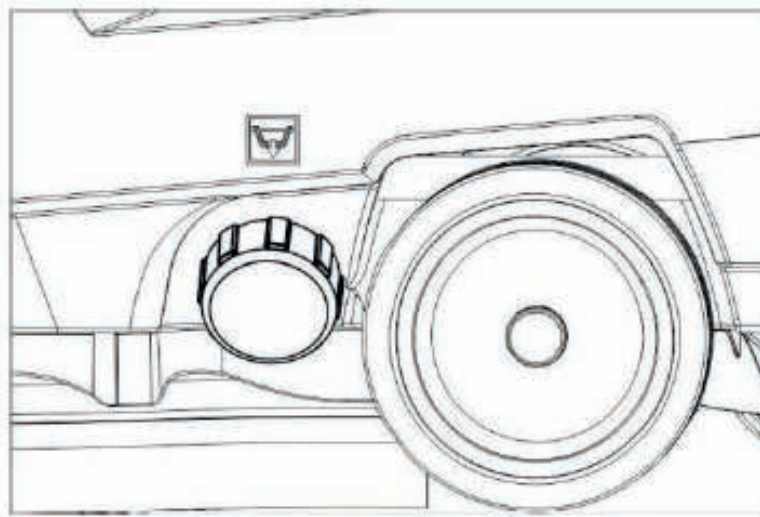

- Unscrew the lock of the fresh water reservoir.

DANGER

Risk of injury! When loading or unloading the machine, it may only be operated on gradients up to the maximum value (see "Technical Specifications"). Drive slowly.

CAUTION

Risk of personal injury or damage! Mind the weight of the appliance during transport.

- Press down and push the device using the push handle.

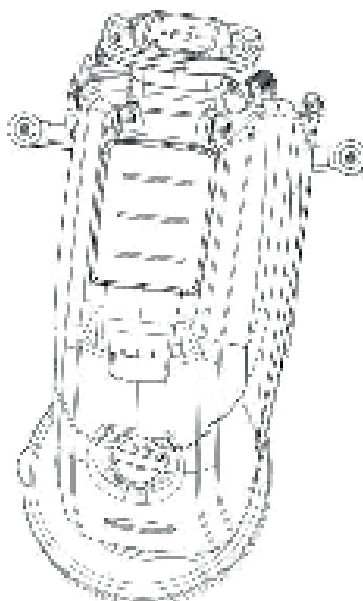

- When transporting in vehicles, secure the appliance according to the guidelines from slipping and tipping over.

CAUTION

Risk of personal injury or damage! Consider the weight of the appliance when storing it.

This appliance must only be stored in interior rooms.

DANGER

Risk of injury! Set the programme selector switch to "OFF" and pull the mains plug of the charger prior to performing any work on the appliance.

Remove the battery plug from machine.

- Drain and dispose of the dirt water and the residual fresh water.

Maintenance schedule

- After each operation

ATTENTION

Risk of damage. Do not sluice the appliance with water and do not use aggressive detergents.

- Drain off dirt water.
- Rinse the waste water tank with clear water.
- Clean the outside of the appliance with a damp cloth which has been soaked in mild detergent.
- Check the fluff filter, clean if required.
- Clean the vacuum lips and the wiping lips, check for wear and replace if required.
- Check the brush for wear and replace if required (see "Maintenance tasks").

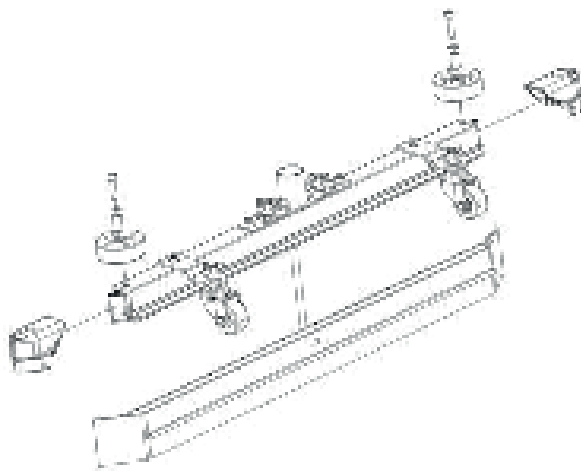

- Monthly

- Check battery poles for oxidation, brush off if necessary. Ensure that the connection cable sits firmly.
- Clean the seals between waste water tank and cover and check for tightness, replace if required.
- Check the acid density of the cells if the batteries are not maintenance-free batteries.

-Yearly

- Have the prescribed inspection carried out by the customer service.

Maintenance works

- Replace or turn vacuum lips

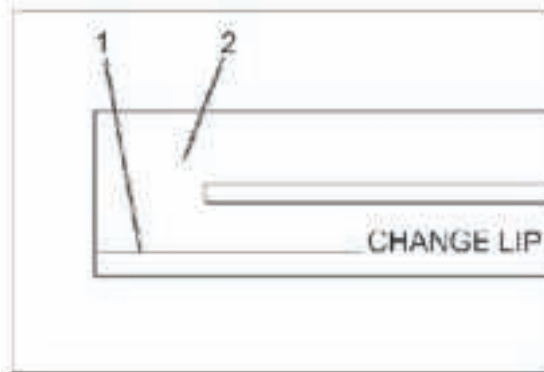

1 Wear indicator

2 Vacuum lip

The vacuum lips must be replaced or reversed if they are worn down to the wear indicator.

- Remove the vacuum bar.
- Unscrew the bolt..
- Remove the plasticparts.
- Remove the vacuumlips.
- Insert new or reversed vacuum lips.
- Insert the plastic parts.
- Screw in and tighten the bolt..

- Replacing the diskbrushes

- Push down the device holding the push handle so that the cleaning head is raised.
- Press the pedal for changing the brushes downward beyond its resistance.
- Pull the device towards the back so that the disc brush becomes accessible.
- Place a new disc brush on the floor in front of the device.
- Drive the device with the raised cleaning head over the new disc brush and lower the cleaning head.
- The brush locks into the drive.

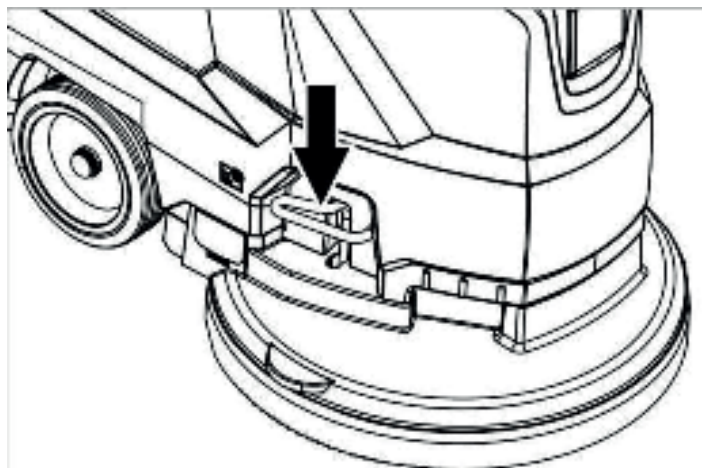

- Removing the waste water tank
- Drain off dirt water.

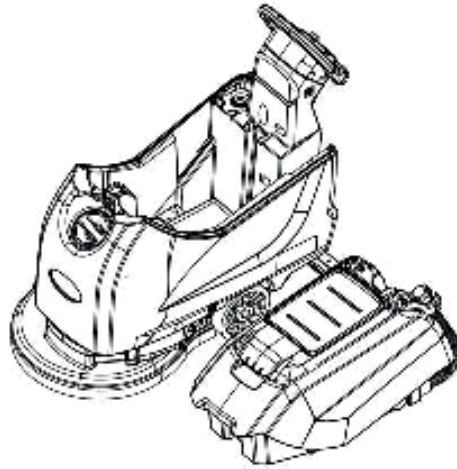

- Lift up the waste water tank and put it aside.

- Batteries

Please observe the following warning notes when handling batteries:



Observe the directions on the battery, in the instructions for use and in the vehicle operating instructions.



Wear eye protection.



Keep children away from acid and batteries.



Danger of explosion.



Fire, sparks, naked flames and smoking must be strictly avoided.



Danger of chemical burns.



First aid.



Warning note.



Disposal.



Do not throw the regular waste.

DANGER

Risk of explosion. Do not place tools or the like on the battery, i.e. on the terminal poles and cell connectors.

Risk of injury. Ensure that wounds never come into contact with lead. Always clean your hands after having worked with batteries.

Recommended batteries

The device requires 2 batteries

1) Complete set (24 V/100 Ah) incl. connecting cable.

Insert batteries and connect

- Drain off dirt water.
- Lift up the waste water tank and put it aside.
- Pull out the battery plug.

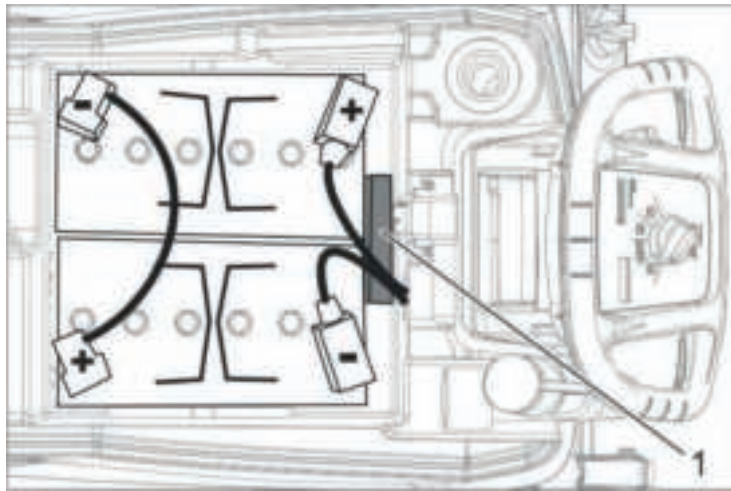

1 Spacer

- Insert the battery into the device as shown above.
- Insert the spacer between the battery and the device on the side indicated in the illustration.

CAUTION

When the batteries are installed and removed, the stability of the appliance can be compromised; ensure a safe stance.

- Connect pole using the enclosed connecting cable.
- Connect the connection cable to the free battery poles (+) and (-).

ATTENTION

If the polarity is reversed (positive and negative terminals), the control electronics are destroyed. Pay attention to correct poles.

- Place the waste water tank on the appliance.

NOTE: Charge the batteries before commissioning the appliance.
See also "Charging the batteries".

Removing the batteries

- Set the programme selector switch to "OFF".
- Pull out the battery plug.
- Lift up the waste water tank and put it aside.
- Clamp off the minus pole of the battery.
- Clamp off the remaining cables from the battery.

- Remove the support blocks or the foam pieces.

CAUTION

When the batteries are installed and removed, the stability of the appliance can be compromised; ensure a safe stance.

- Remove the batteries.
- Dispose of the used batteries according to the local provisions.

Maintenance contract

To ensure a reliable operation of the appliance maintenance contracts can be concluded with the competent sales office.

In case of danger of frost:

- Empty the fresh and waste water tank.
- Store the appliance in a frost-protected room.

DANGER

Risk of injury! Set the programme selector switch to "OFF" and pull the mains plug of the charger prior to performing any work on the appliance.

Remove the battery plug from machine.

- Drain and dispose of the dirt water and the residual fresh water.

Faults without display on the console

Failure	Correction
Appliance cannot be started	Turn the program selection switch to the desired programme. Operate the safety switch. Insert battery plug. Check battery; charge it if required. Make sure that all battery terminals are connected.
Insufficient water quantity	Check fresh water level, refill tank if necessary. Increase the water volume on the regulating knob for water volume.
Insufficient vacuum performance	Clean the seals between waste water tank and cover and check for tightness, replace if required. Waste water reservoir is full; shut off the appliance and empty the wastewater reservoir Clean the fluff filter. Clean the vacuum lips on the vacuum bar, replace if required Check if the cover on the dirt water discharge hose is closed Check the setting of the vacuum bar. Check suction hose for blockages; clean if required. Check the suction hose for tightness; replace if required.

Insufficient cleaning result	Check the brushes for wear, replace if required. Suction turbine is running rough
Suction turbine is running rough	Clean the swimmer.
Brush does not turn	Check if foreign objects block the brush; remove foreign object if required. If over-current switch in the electronics system has been triggered, turn programme selection switch to "OFF". Afterwards, set it back to the desired programme.
Vibrations during cleaning	You might need to use a softer brush.
In case of faults that cannot be remedied using the table below please contact the customer service.	

Cleaning the floater

- Open the cover of the waste water tank.

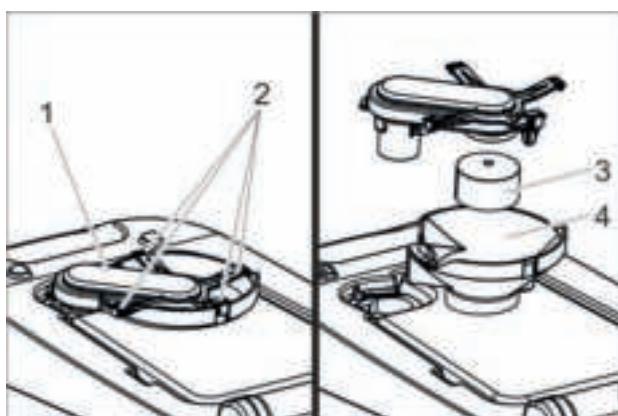

- 1 Swimmer casing
- 2 Lock hook
- 3 Float
- 4 Lower part

- Pull out the float casing towards the top.
- Detach locking hooks.
- Clean float and bottom part.
- Assemble the float casing and insert it into the device.

Disk brush, red (medium, standard)	For the use with all common cleaning tasks.
Disk brush, natural (white)	Made of natural fibres for spot cleaning and polishing.
Disk brush, black (hard)	For heavy soiling and for deep cleaning. For robust floorings only.
Driver plate pad	For cleaning with pads. With quick change coupling and center lock.
Pad, red (medium soft)	For cleaning and cleaning of all floors.
Pad, green (medium hard)	For cleaning heavily soiled floors and for deep cleaning.
Pad, black (hard)	With stubborn soiling and for deep cleaning.
Pad, beige (light grain)	For polishing and refreshing of hard and flexible floorings.
Pad, beige (natural hair proportion)	
Suction bar, 850 mm, straight	

Power

Battery: 24V/ 100 Ah

Average power consumption: 1000 W

Power suction turbine: 500 W

Power brush drive: 500 W

Max running time: 5 h

Vacuuming

Vacuum power, air volume (max.): 24 L/s

Vacuuming power, negative pressure (max.): 120 kPA (mbar)

Cleaning brushes

Brush speed: 175 rpm

Brush diameter: 510 mm

Dimensions and weights

Theoretical surface cleaning performance: 2000 m²/h

Suction width: 850 mm

Cleaning width: 510 mm

Max. working range incline: 2%

Fresh/ waste water tank volume: 50/ 50 L

Max. water temperature 60°C

Ambient temperature 5 - 40°C

Net weight 160 kg

Dimensions of battery compartment: 350 x 350 mm

Values determined as per EN60335-2-72

Total oscillation value: < 2.5 m/s²

Uncertainty K: 0.2 m/s²

Sound pressure level L_{pa}: 66 dB(A)

Uncertainty K_{pa}: 2 dB(A)

Sound power level L_{wa} ±: 81 dB(A)

Vehicle structure diagram

S/N	Parts	QTY	S/N	Parts	QTY	S/N	Parts	QTY
1	Sewage tank	1	8	control unit base plate	1	15	display panel	1
2	Clear water tank	1	9	control unit	1	16	M3X10 copper column	4
3	brush	1	10	M4X12 cross recessed countersunk head screws	4	17	M3X6 cross countersunk head bolt	8
4	After absorbing steak	1	11	M4 nut	4	18	Large cross pan head screw M5X10	4
5	Battery	1	12	Tapping bolt	2	19	Hexagon socket screw with round head M3X24	4
6	Battery tray	1	13	Display plate bottom plate	1			
7	Pushing handlebar	1	14	Display board stickers	1			

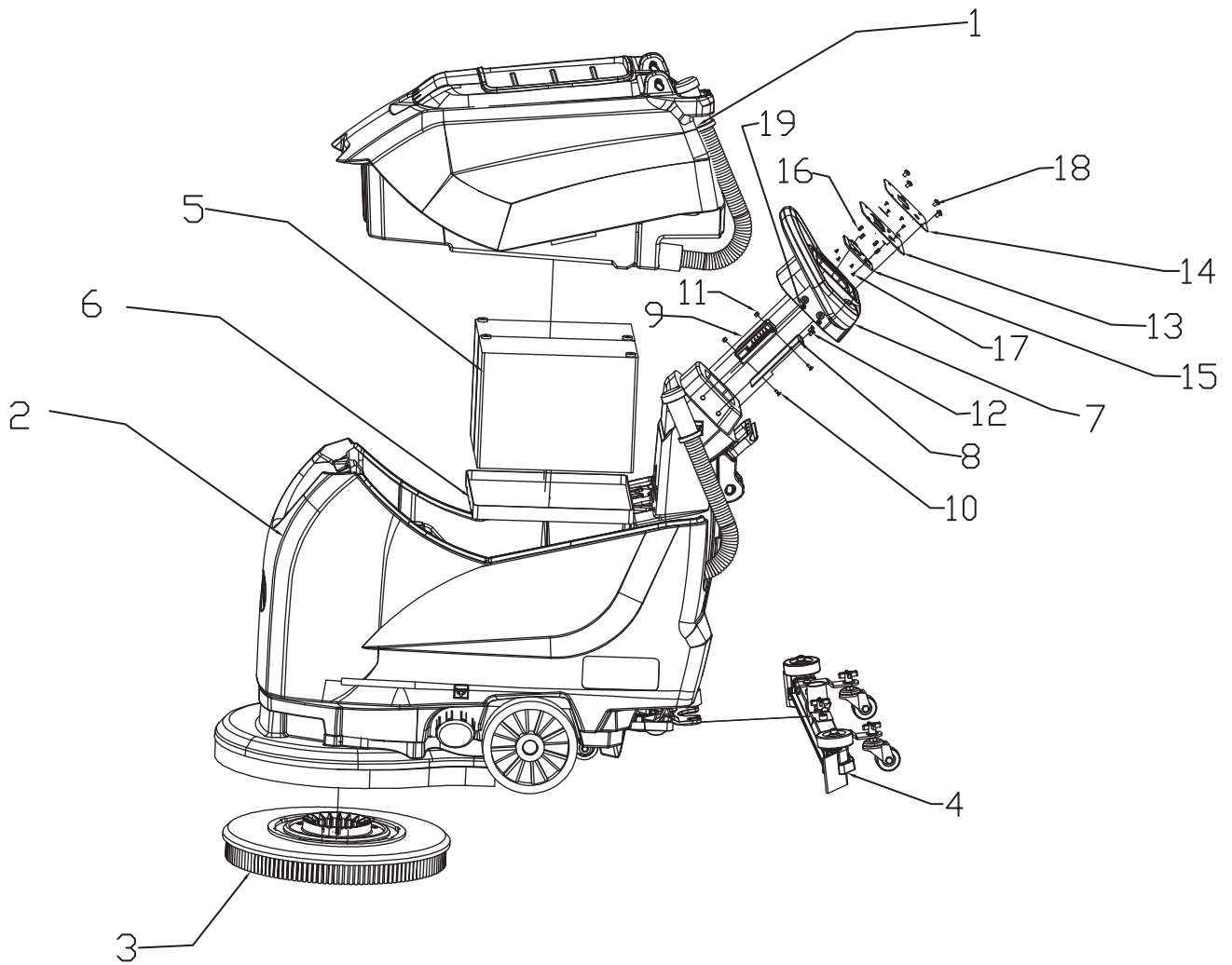

Transport angle wheel structure diagram

S/N	Parts	QTY
1	Bottom plate of transport Angle wheel	1
2	Transport Angle wheel foot shaft	1
3	Thickened gasket M15	1
4	15 circlip	1
5	Mounting plate for transportation Angle wheel	1
6	Transport Angle wheel spring	1
7	Transport Angle wheel axle	1
8	12 circlip	2
9	Thickened gasket M12	2
10	Transport Angle wheel spacer 1	1
11	Transport Angle wheel spacer 2	1
12	Transportation Angle of wheel	1

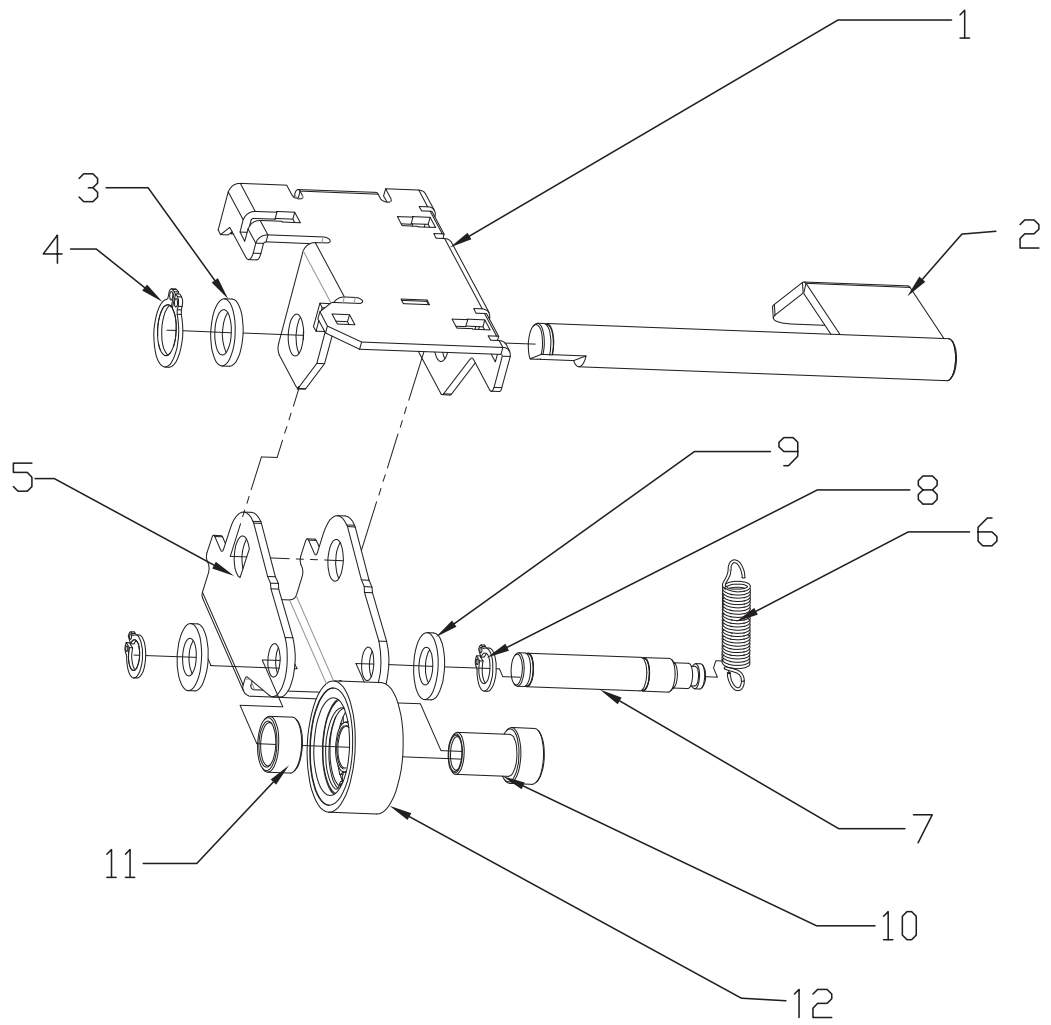

Sewage tank structure diagram

S/N	Parts	QTY
1	Sewage tank	1
2	blow-off pipe	1
3	Float bucket base	1
4	floating ball	1
5	Center seat of float bucket	1
6	Float barrel seal ring	1
7	Float barrel cover plate	1
8	Sewage tank cover seal ring	1
9	Sewage tank cover	1
10	Double tap plum screw PWB5X16X10	1

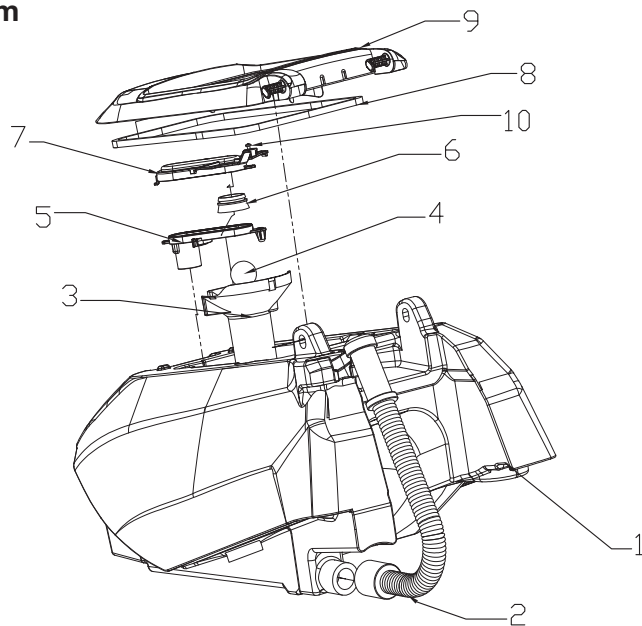

Drawing of suction rack structure

S/N	Parts	QTY
1	Aluminum absorption adjustment rack	1
2	Aluminum suction rack holder	1
3	Gripper adjustment knob	1
4	Gripper adjusting knob fixing plate	1
5	The M5 flat gasket	2
6	Hexagon socket bolt M5	2

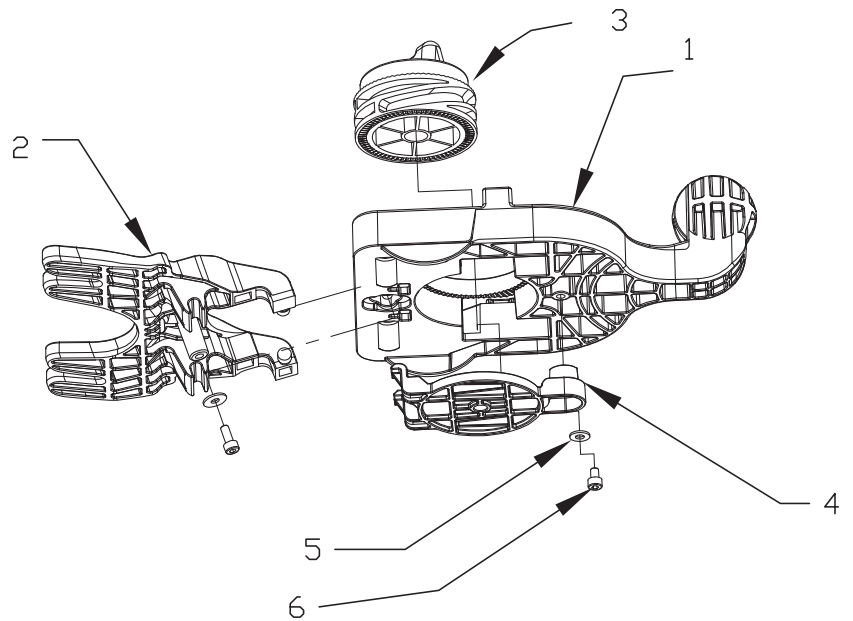

Structure diagram of clean water tank

S/N	Parts	QTY	S/N	Parts	QTY
1	clean water tank	1	8	water volume adjustment link	1
2	filler cap	1	9	suction pull handle	1
3	water tank sealing ring1	1	10	suction pull rope	1
4	water tank sealing ring2	1	11	fixed plate for transport angle wheel	1
5	power plug base	1	12	M6 flat washer	4
6	double bottom self tapping plum screw PWB5X20X16	2	13	locknut M6	4
7	water volume adjustment knob	1	14	suction and pull impeachment bracket	1

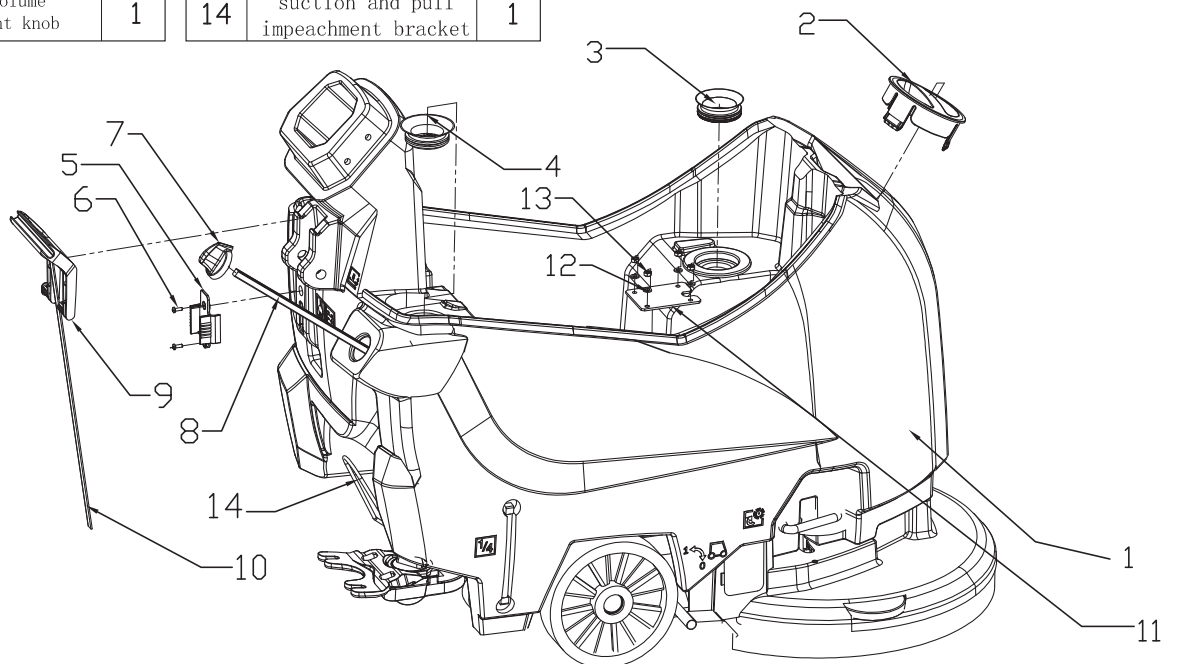

S/N	Parts	QTY
1	clean water tank	1
2	drain cover	1
3	rear suction bracket	1
4	water regulating valve bracket	1
5	water regulating valve	1
6	water control valve seal	1
7	double bottom self tapping plus screw PWB5X20X16	2
8	suction bracket fixing plate	1
9	double bottom self tapping plus screw PWB5X16X10	1
10	suction motor seal ring	1
11	vacuum motor	1
12	vacuum motor mounting plate	1
13	M6 flat washer	3
14	Hexgon socket bolt M6X20	3
15	M4 flat washer	4
16	Cross self-tapping screws 4X10	4
17	transportation angle of wheel	1
18	Round hend square diameter bolt M6	4
19	support wheel	1
20	driving wheel	2
21	6204 bearing	4
22	M6 flat gasket	2
23	M6 spring shim	2
24	M6X25 hexagon socket screw	2
25	M6 hexagon socket screw	1
26	Axle fixing plate	2
27	Axle fixed base plate	2
28	set bolt	2
29	Brush plate component	1
30	Cross tapping screw TB6X15.5	17
31	Water valve baffle cover	1
32	Clear water water cover seal ring	1
33	axle	1
34	20 circlip	2
35	wheel drain cover	2
35	suction bracket fixing plate stiffener	1

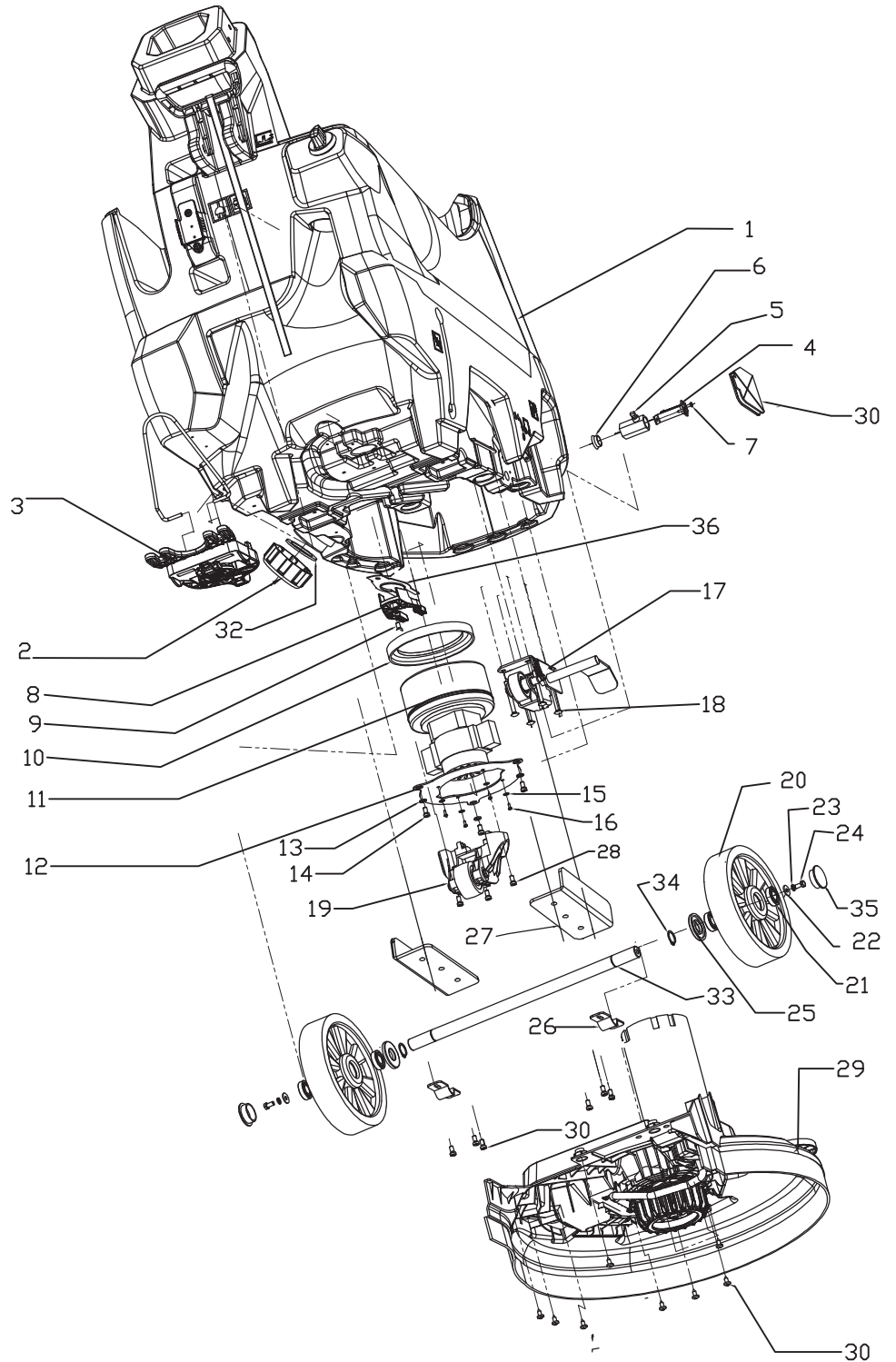

Brush structure diagram

S/N	Parts	QTY
1	Brush motor	1
2	Brush plate cover	1
3	Brush plate motor fixed bottom plate	1
4	Hexagon socket bolt M6X10	10
5	Aluminum card	1
6	M8 big gasket	1
7	M8 play mat	1
8	Hexagon socket bolt M8X20	1
9	Discharge brush plywood	1
10	Remove brush splint fixing card	2
11	weather bar	1
12	Double tap plum screw PWB5X16X10	9
13	Brush disc housing collision wheel Fixed plate	1
14	Brush disc housing collision wheel	1
15	Brush disc housing support wheel	1
16	M5 big gasket	2
17	Remove brush splint spring	1

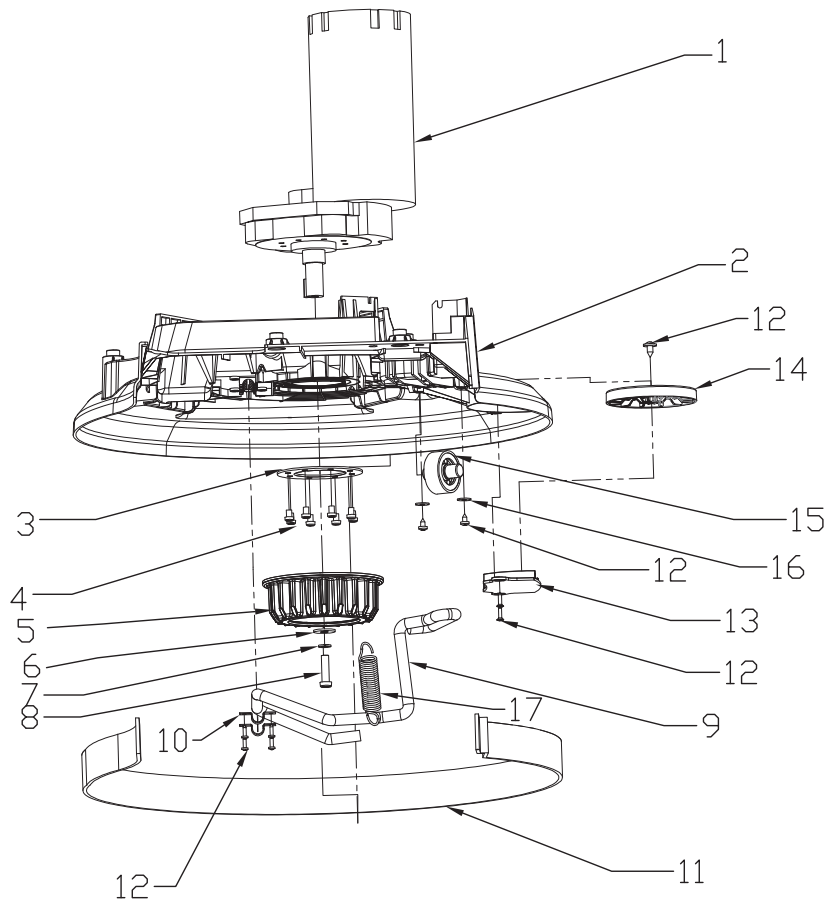

Suction structure diagram

S/N	Parts	QTY
1	Aluminum alloy absorption rack	1
2	Before and after the strip	1
3	Suction strip block (symmetric)	2
4	Suction side cover (symmetric)	2
5	fender wheel	2
6	Anti-collision wheel spacer	2
7	M8 flat gasket	4
8	Hexagon socket bolt M8X35	2
9	Pollution mouth	1
10	Suction lip press	1
11	Suction mounting platen	1

S/N	Parts	QTY
12	Round head hexagon socket bolt M8X25	2
13	M8 big gasket	4
14	Cross handwheel bolt	2
15	Universal wheel bottom plate	2
16	M8x25 Hexagonal round head bolt	2
17	Cross hand wheel nut	2
18	universal wheel	2

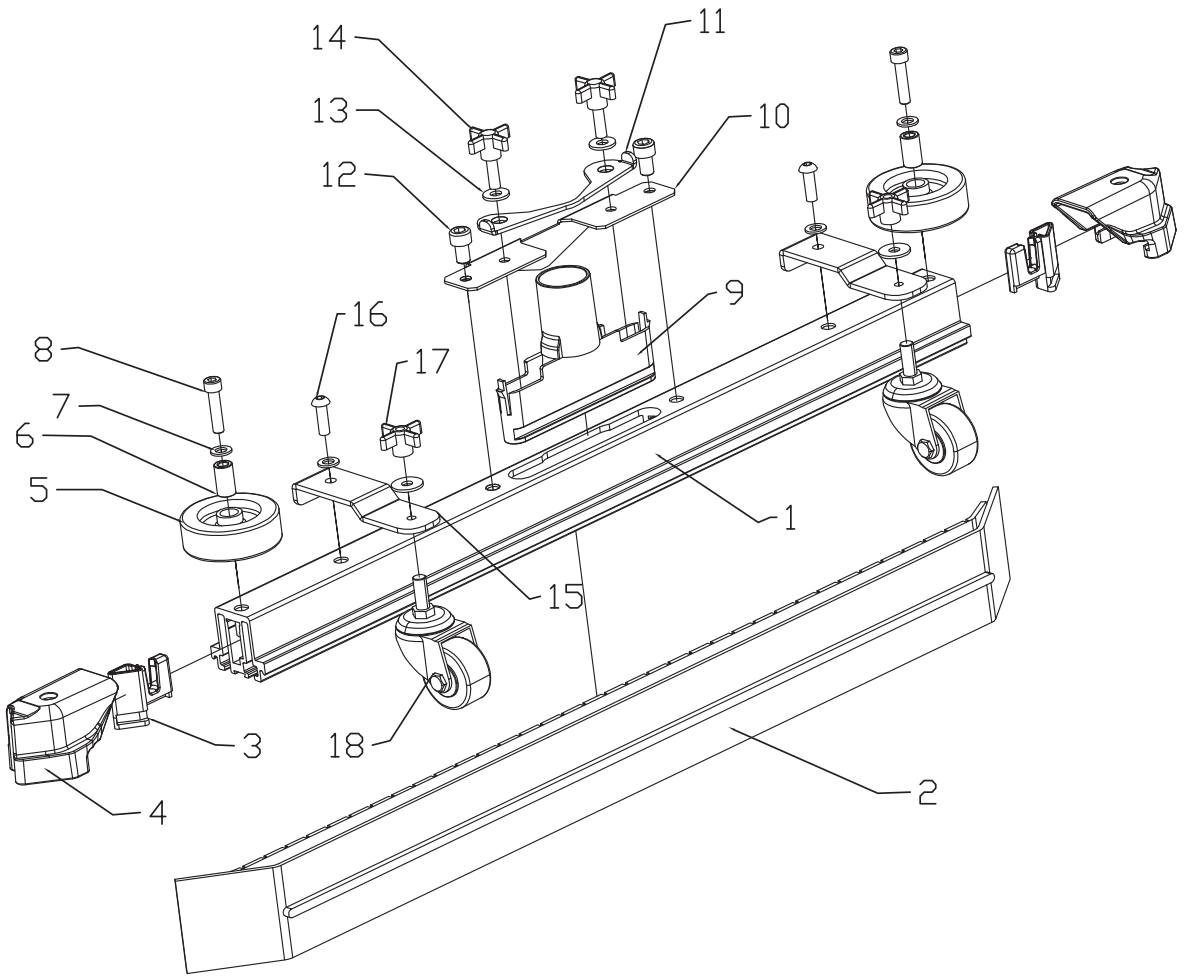

Scrubber dryer

Model: DAFL50A

Brand: **DAEWOO**

We GBR Corp. LTD, Room 1002, 10/F., David House, 8-20 Nanking Street, Jordan, Kowloon, Hong Kong, China, declare under our sole responsibility that this product is in conformity and accordance with the following standards and regulations.

The undersigned is responsible for the compilation of technical documentation.

Satisfies the requirement of the Council Directives:

Machinery Directive 2014/30/EU

Electromagnetic Compatibility Directive EMC 2014/35/EU

Noise Directive 2006/42/EC (Measured sound power level: Unlimited dB (A),

Guaranteed sound power level: 86dB (A)

and conforms to the norms:

EN ISO 60204-1: 2006+A1:2009

EN ISO 12100: 2010

Signature and Stamp on undersigned responsible.

Date: 15-01-2022

A handwritten signature in black ink is written over a circular blue stamp. The stamp contains the text 'GBR' at the top and 'DAEWOO' at the bottom, with a central dot.

WARRANTY CARD

Product model	Date of sale
Serial number	Company
Username	Client's signature

The product is in good conditions and fully complete. Read and agree the terms of the warranty.

GUARANTEE

The warranty period starts from the date of sale of the products and covers 2 years for all power products.

During the warranty period, free failures caused due to the use of poor-quality materials in the production and manufacturer workmanship admitted fault are removed. The guarantee comes into force only when warranty card and cutting coupons are properly filled. The product is accepted for repair in its pure form and full completeness.

WARRANTY DOES NOT COVER

- Mechanical damage (cracks, chips, etc.) and damage caused by exposure to aggressive media, foreign objects inside the unit and air vents, as well as for damage occurred as a result of improper storage (corrosion of metal parts);
- Failures caused by overloading or product misuse, use of the product for other purposes. A sure sign of overload products is melting or discoloration of parts due to the high temperature, simultaneous failure of two or more nodes, teaser on the surfaces of the cylinder and the piston or destruction of piston rings. Also, the warranty does not cover failure of the automatic voltage regulator due to incorrect operation;
- Failure caused by clogging of the fuel and cooling systems;
- Wearing parts (carbon brushes, belts, rubber seals, oil seals, shock absorbers, springs, clutches, spark plugs, mufflers, nozzles, pulleys, guide rollers, cables, recoil starter, chucks, collets, removable batteries, filters and safety elements, grease, removable devices, equipment, knives, drills, etc.);
- Electrical cables with mechanical and thermal damage;
- Product opened or repaired by a non-authorized service center.
- Prevention, care products (cleaning, washing, lubrication, etc.), installation and configuration of the product;
- Natural wear products (production share);
- Failures caused by using the product for the needs related to business activities;
- If the warranty card is empty or missing seal (stamp) of the Seller;
- The absence of the holder's signature on the warranty card.

----- ✂ -----

Product _____	Product _____	Product _____
Model _____	Model _____	Model _____
Company _____	Company _____	Company _____
Date of sale _____	Date of sale _____	Date of sale _____

