

# Instruction manual

Thank you for purchasing this product.  
Before using this product please read the instructions carefully.  
After reading the instruction manual, please keep it for reference.

## Table of Contents

How to Connect	2
Included	2
Platform	2
Layout	3
How to Mount	4
Control Toggle Switch	4
Button Hold function	4
Assign Mode	5
Quick Handling Mode	6
Adjustable Sensitivity	6
Adjustable Dead Zone	7
Reset back to default settings	8
Caution	8
Main Specifications	8

## How to Connect

- Make sure that direction of modular plug is correct before connecting.
- This product can be used without the foot pedals.

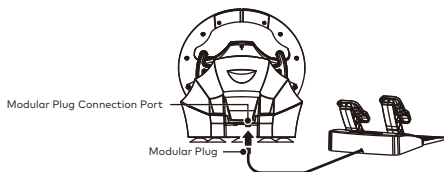

\* This product is not a wireless controller.

Turn the steering wheel to its maximum rotation position once in both directions.  
Press down fully into each of the L pedal and R pedal once.

- Please repeat the process when you re-connect the controller or restart the Nintendo Switch™ or PC system.

## Included



Steering Unit



Foot Pedals



Suction Cups



Clamp



Screw



Instruction Manual

## Platform

### Nintendo Switch™ / PC(Xinput)

\* Functions as PC controller through Xinput.  
This product does not support DirectInput.

Supported OS	Windows®10 / 8~8.1 / 7
System requirements	USB Port, Internet Connection

#### Important

Make sure that your Nintendo Switch™ is updated with the latest system software.

May not function for titles that require motion control.

Steering Unit (Front View)

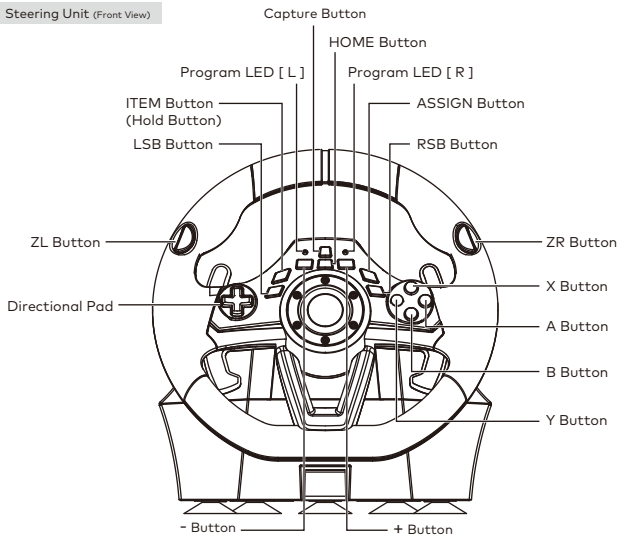

Steering Unit (Back View)

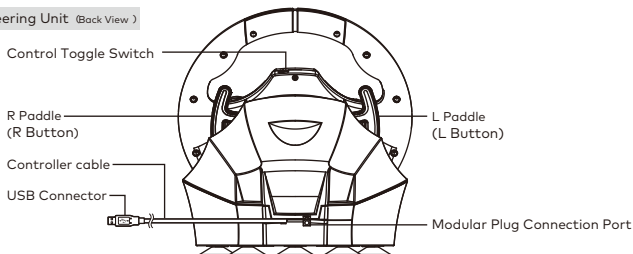

Foot Pedals

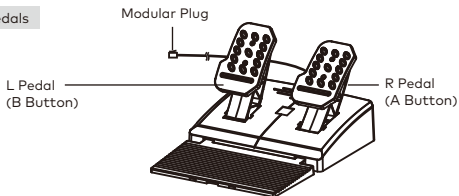

## How to Mount

### Steering Unit

#### Option 1: Suction Cup

- 1 Remove all dust and dirt from your tabletop before securing the controller using the five suction cups.
- 2 Attach suction cups to steering unit when setting up.



#### Option 2: Clamp

- 1 Tighten the clamp screw into the steering wheel base.
- 2 Use the clamp to secure the steering unit to a flat, hard surface (i.e. table).



- Do not combine both securing methods as it may damage the suction cups.
- Do not affix to furniture made from glass or other fragile materials.
- Detach from furniture carefully to prevent damage to furniture or product.

### Foot Pedals

Place foot pedals onto a flat surface.



## Control Toggle Switch

Directional pad controls can be toggled to directional pad, left stick or right stick controls.

This product's directional pad toggle function is not guaranteed to work with all software.

- Please refer to software's instruction book. This product does not work with Analog mode.



Directional pad



Left stick



Right stick

## Button Hold function

Push and hold the Hold button to maintain the pushed state after releasing your finger.

### How to Enable

Press for 1 second



Red LED turns on.

### How to Disable

Press Once



Red LED turns off.

ZL button / ITEM button / L Paddle

Button Hold function works only when ITEM button has ITEM function.

## CAUTION When playing Mario Kart

While the Button Hold function is enabled: If you want to use the item you pick up, press any of the ZL button / ITEM button / L Paddle once to disable the Button Hold function. Then press the button again to use the item.

## ■ Assign Mode

You can remap the function of buttons using this feature.

### Programmable Buttons

ZL / ZR / LSB / RSB / ITEM / L Paddle / R Paddle / L Pedal / R Pedal

### Assignable Functions

A / B / X / Y / L / R / ZL / ZR / LSB / RSB / ITEM / L Paddle / R Paddle  
Directional Pad (Right / Down / Left / Up) / Left stick (Right / Down / Left / Up) / Right stick (Right / Down / Left / Up)

### How to Adjust

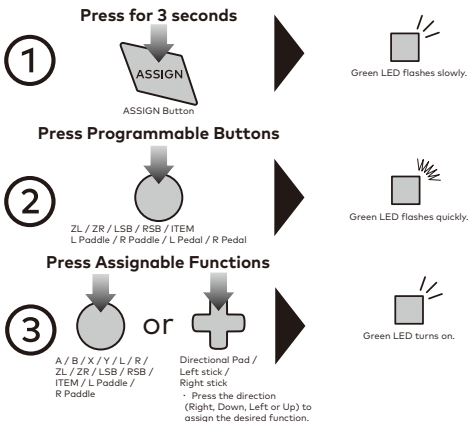

- After 4 seconds of inactivity between steps, Program LED (Right) will turn off and program mode will stop.
- During steps 2, button input from the controller to the Nintendo Switch™ will be disabled.
- When the Program LED (Left) turns on, it indicates that a button is remapped and will not turn off until button function is reset to default.
- If you want to disable button function, press and hold for 3 seconds the same button you pressed in step 2 at the time of step 3.
- If you pressed multiple buttons during step 3, the last button you pressed will be assigned.
- Controller settings are stored even if the USB is disconnected.

### How to reset individual buttons

Use the Step 3 above to individually reset buttons to default.

### How to reset all buttons / functions to default

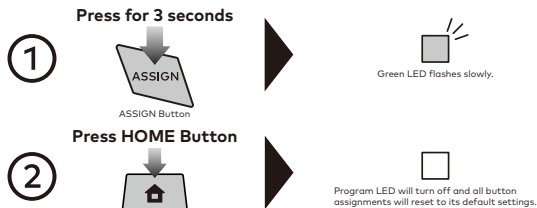

## Quick Handling Mode

Experience quicker handling by switching the max steering output from 270 degrees to 180 degrees.

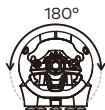

180°

Press together

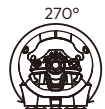
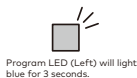

270°

Press together

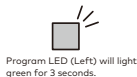

## Adjustable Sensitivity

Steering wheel sensitivity is adjustable to seven levels. The Program LED (Left) colour will change to indicate the sensitivity value.

### Steering Unit

Press for 3 seconds

1

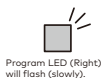

2

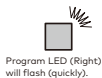

3

Set Control Toggle Switch to LS



4



Sensitivity value increases by pressing up on the Directional Pad.

Responsive

5



Sensitivity value decreases by pressing down on the Directional Pad.

Gradual

6

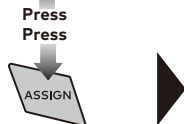

(The Program LED (Right) will light green when assigning buttons.)

- If you do not perform step ② after ①, the Program LED (Right) will turn off after four seconds and button assignment mode will automatically end.
- During steps 2~6, only the steering unit and foot pedal input are enabled.  
Button input from the controller to the Nintendo Switch™ will be disabled.
- Controller settings are stored even if the USB is disconnected.

	Gradual (Steady steering)			Default	Responsive (Easy to turn)		
	1	2	3	4	5	6	7
LED colour	Green	Yellow	Red	Purple	Blue	Light Blue	White

## ■ Adjustable Dead Zone

The Dead Zone is adjustable to seven levels.  
Program LED (Left) colour will change to indicate the dead zone value.

### Press for 3 seconds

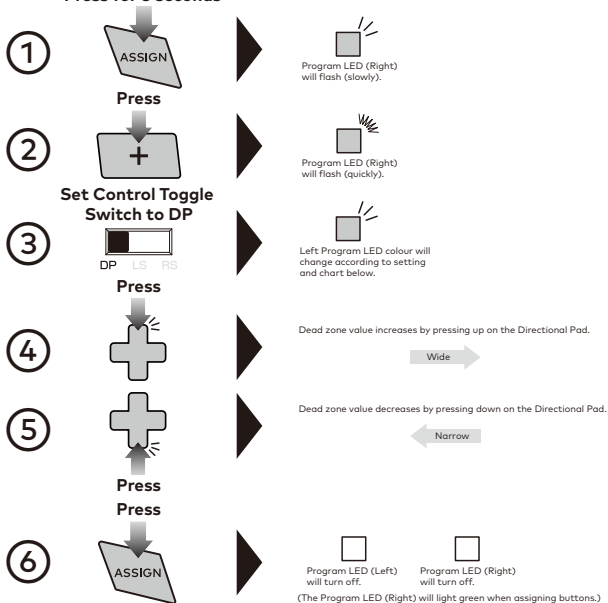





- If you do not perform step ⑥ after ⑤, the Program LED (Right) will turn off after four seconds and button assignment mode will automatically end.
- During steps 2~6, only the steering unit and foot pedal input are enabled.  
Button input from the controller to the Nintendo Switch™ will be disabled.
- Controller settings are stored even if the USB is disconnected.

	Narrow			Default	Wide		
	1	2	3	4	5	6	7
LED	Green	Yellow	Red	Purple	Blue	Light Blue	White

## ■ Reset back to default settings

To simultaneously reset all of the following: Quick Handling Mode · Dead Zone Adjustment · Sensitivity Adjustment.

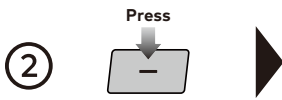
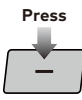
### Press for 3 seconds

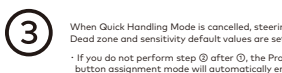
-  ①  →   
Program LED (Right) will flash (slowly).
-  ②  →    
Program LED (Left) will turn off. Program LED (Right) will turn off.  
(The Program LED (Right) will light green when assigning buttons.)
-  ③ When Quick Handling Mode is cancelled, steering wheel input value will default to 270°. Dead zone and sensitivity default values are set to "4".
  - If you do not perform step ② after ①, the Program LED (Right) will turn off after four seconds and button assignment mode will automatically end.

## ■ Caution

- Never disassemble, repair, or modify this product.
- Keep the controller away from dusty or humid areas.
- Do not apply strong impact or weight on the product.
- Do not pull roughly or bend the cable of the controller.
- If product needs cleaning, use only a soft dry cloth. Do not use any chemical agents like benzine or thinner.
- Keep this product out of the reach of children under 3.

## ■ Main Specifications

### Steering Unit

External Dimensions : 280 × 275 × 286mm

Steering Diameter : 280mm

Weight : 1400g

Angle of Rotation : 270°

Cable Length : 3m

### Foot Pedals

External Dimensions : 234 × 305 × 180mm

Weight : 700g

Cable Length : 1.5m



#### THE FCC WANTS YOU TO KNOW

This device complies with part 15 of the FCC Rules. Operation is subject to the following two conditions:

(1) This device may not cause harmful interference, and (2) this device must accept any interference received, including interference that may cause undesired operation.

#### THE FCC WANTS YOU TO KNOW

This equipment has been tested and found to comply with the limits for a Class B digital device, pursuant to Part 15 of the FCC Rules. These limits are designed to provide reasonable protection against harmful interference in a residential installation.

This equipment generates, uses and can radiate radio frequency energy and, if not installed and used in accordance with the instructions, may cause harmful interference to radio communications.

However, there is no guarantee that interference will not occur in a particular installation.

If this equipment does cause harmful interference to radio or television reception, which can be determined by turning the equipment off and on, the user is encouraged to try to correct the interference by one or more of the following measures:

- Reorient or relocate the receiving antenna.
- Increase the separation between the equipment and receiver.

#### PRODUCT DISPOSAL INFORMATION

Where you see this symbol on any of our electrical products or packaging, it indicates that the relevant electrical product or battery should not be disposed of as general household waste in Europe. To ensure the correct waste treatment of the product and battery, please dispose of them in accordance with any applicable local laws or requirements for disposal of electrical equipment or batteries. In so doing, you will help to conserve natural resources and improve standards of environmental protection in treatment and disposal of electrical waste.

Applicable to EU countries and Turkey only.



EU and Turkey only

#### US

##### Warranty

HORI warrants to the original purchaser that the product purchased new in its original packaging shall be free of any defects in material and workmanship for a period of 90 days from the original date of purchase. If the warranty claim cannot be processed through the original retailer please contact HORI customer support directly at [infocus@hori.jp](mailto:infocus@hori.jp).

Please visit <http://stores.horiusa.com/policies/> for warranty details.

#### EU

##### Warranty

For all warranty claims made within the first 30 days after purchase, please check with the retailer where the original purchase was made for details. If the warranty claim cannot be processed through the original retailer or for any other inquiries pertaining to our products, please contact HORI customer support directly at [infocus@hori.jp](mailto:infocus@hori.jp).

Warning, Not suitable for children under 36 months, Long cord, Strangulation hazard.

The image on the package may differ from the actual product.

The manufacturer reserves the right to change the product design or specifications without notice.

The wires are not to be inserted into socket-outlets.

The packaging must be retained since it contains important information.

HORI & HORI logo are registered trademarks of HORI.



MADE IN CHINA

# Mode d'emploi

Merci d'avoir acheté ce produit.

Veillez lire attentivement les instructions avant d'en commencer toute utilisation.  
Après avoir lu le feuillet d'instructions, veuillez le conserver à portée de main pour future référence.

## Sommaire

Comment se connecter	11
Inclus	11
Plateforme	11
Description	12
Installation	13
Interrupteur à bascule du Pad Directionnel	13
Fonction de maintien du bouton	13
Mode ASSIGN	14
Mode Pilotage	15
Réglage de la sensibilité	15
Réglage de la zone morte	16
Réinitialiser les paramètres par défaut	17
Attention	17
Caractéristiques principales	17

## ■ Comment se connecter

- Connectez la prise modulaire des Pédales au port de connexion modulaire du Volant.
- Ce produit peut être utilisé sans les Pédales.

Port de connexion de la prise modulaire.

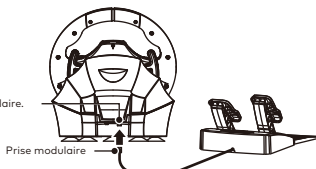

\* Ce produit n'est pas une manette sans fil.

- Appuyez fermement une fois sur les deux pédales L et R.(·) Vous êtes maintenant prêt à jouer.
- Répétez le processus lorsque vous rebranchez le volant ou redémarrez la console Nintendo Switch™ ou PC.

## ■ Inclus



Volant



Pédales



Ventouses



Attache



Vis



Mode d'emploi

## ■ Plateforme

### Nintendo Switch™ / PC(Xinput)

\* Fonctionne comme manette PC via Xinput.  
Ce produit ne prend pas en charge DirectInput.

OS supporté	Windows®10 / 8~8.1 / 7
Exigence Système	Port USB, Connexion Internet

#### Important

Assurez-vous que votre Nintendo Switch™ est mise à jour avec le logiciel le plus récent.

Peut ne pas fonctionner avec les jeux nécessitant la détection de mouvement.

## Description

### Base du volant (Vue de face)

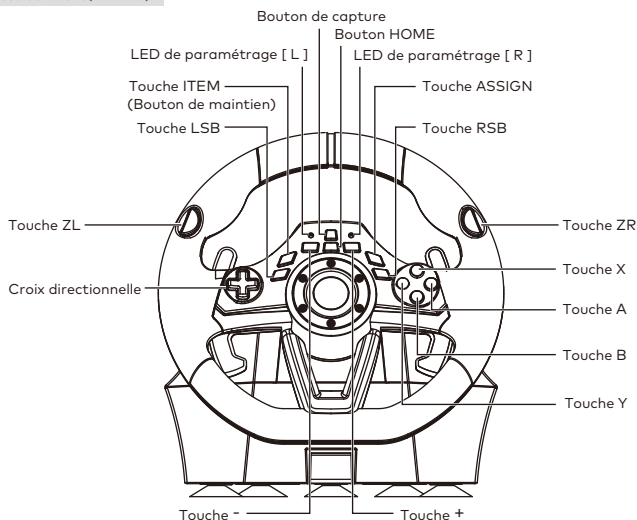

### Base du volant (Vue arrière)

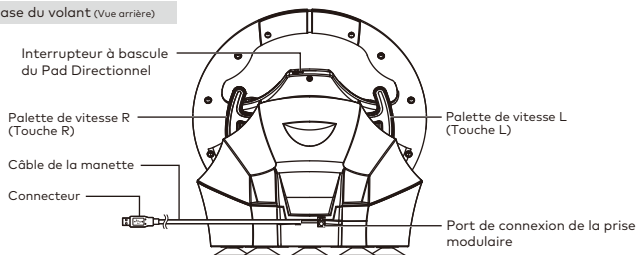

### Pédales

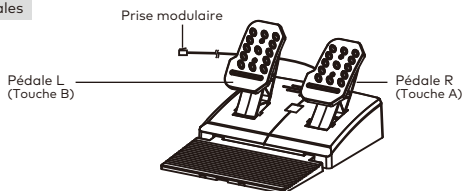

## ■ Installation

### Base du volant

Option 1: Ventouse

- 1 Placez les ventouses à la base du volant.
- 2 Veuillez enlever toute poussière ou saleté de la table avant de fixer la manette grâce aux cinq ventouses.

Option 2 : Attache

- 1 Serrez la vis de l'attache dans la base du volant.
- 2 Utilisez l'attache pour mettre en place la base du volant sur une surface plane et rigide (ex : table)



- Veuillez ne pas combiner les deux méthodes de mise en place car cela peut endommager les ventouses.
- Ne pas fixer sur une surface en verre ou faite de matériaux fragiles.
- Retirer le produit du meuble utilisé avec précaution afin de ne n'en abîmer aucun des deux.

### Pédales

Utilisez les pédales en les plaçant sur une surface plane au sol.



## ■ Interrupteur à bascule du Pad Directionnel

Le pavé directionnel peut être configuré pour fonctionner comme un stick gauche, un stick droit ou comme pavé directionnel. Le bon fonctionnement de l'interrupteur bouton directionnel de ce produit n'est pas garanti pour fonctionner avec tous les logiciels.

• Se référer au manuel d'instructions des logiciels. Ce produit ne fonctionne pas avec le mode analogique.



Croix directionnelle



Stick gauche



Stick droit

## ■ Fonction de maintien du bouton

Appuyez sur le bouton de maintien et maintenez-le enfoncé pour maintenir l'état enfoncé après avoir relâché votre doigt.

Activation

Appuyez pendant 1 seconde



Le voyant s'allume rouge.

Désactivation

Appuyez une fois



Touche ZL / Touche ITEM / Palette de vitesse L



La LED rouge s'éteint.

Si la fonction d'un autre bouton est attribuée à la touche ITEM, la fonction "Maintenir enfoncé" ne sera pas activée si vous appuyez dessus.

## ATTENTION Lorsque vous jouez à Mario Kart

Si la fonction "Maintenir" est activée, pour utiliser l'objet que vous avez collecté, appuyez d'abord sur l'un des boutons suivants pour le désactiver: ZL / ITEM / palette de gauche. Ensuite, appuyez à nouveau sur le bouton pour utiliser l'objet.

Vous pouvez reprogrammer les fonctions des boutons avec cette fonctionnalité.

Boutons Programmables

ZL / ZR / LSB / RSB / ITEM / Palette de vitesse L / Palette de vitesse R / Pédale L / Pédale R

Fonctions assignables

A / B / X / Y / L / R / ZL / ZR / LSB / RSB / ITEM / Palette de vitesse L / Palette de vitesse R / Croix directionnelle (Droite / Bas / Gauche / Haut) / Stick gauche (Droite / Bas / Gauche / Haut) / Stick droit (Droite / Bas / Gauche / Haut)

Comment ajuster

Appuyez pendant 3 secondes

1



Touche ASSIGN



Le voyant vert clignote lentement.

Appuyez Boutons Programmables

2



ZL / ZR / LSB / RSB / ITEM / Palette de vitesse L / Palette de vitesse R / Pédale L / Pédale R



Le voyant vert clignote rapidement.

Appuyez Fonctions assignables

3



A / B / X / Y / L / R / ZL / ZR / LSB / RSB / ITEM / Palette de vitesse L / Palette de vitesse R



Croix directionnelle / Stick gauche / Stick droit



Le voyant s'allume vert.

· Appuyer sur les touches directionnelles (Droite, Bas, Gauche, Haut) pour les assigner aux paramètres voulu



- Après 4 secondes d'inactivité entre les étapes, la LED de programmation (droite) s'éteint et le mode de programmation s'arrête.
- Au cours de l'étape 2, les boutons de la manette Nintendo Switch™ seront désactivés.
- Lorsque le voyant de programmation (gauche) s'allume, cela signifie qu'un bouton est modifié. Il ne s'éteindra pas jusqu'à ce que la fonction du bouton soit réinitialisée.
- Si vous souhaitez désactiver la fonction des boutons, maintenez enfoncé pendant 3 secondes le même bouton que celui utilisé à l'étape 2 au moment de l'étape 3.
- Si vous avez appuyé sur plusieurs boutons à l'étape 3, le dernier bouton sur lequel vous avez appuyé sera attribué.
- Les paramètres du contrôleur sont stockés même si le périphérique USB est déconnecté.

Comment réinitialiser les boutons individuels

Utilisez l'étape 3 ci-dessus pour réinitialiser individuellement les boutons par défaut

Comment réinitialiser tous les boutons / fonctions aux valeurs par défaut

Appuyez pendant 3 secondes

1



Touche ASSIGN



Le voyant vert clignote lentement.

Appuyez Bouton HOME

2



La LED de programmation s'éteint et toutes les affectations des boutons seront réinitialisées à leurs paramètres par défaut.

## Mode Pilotage

Profitez d'une expérience de conduite plus rapide en ajustant l'angle de rotation de 270° à 180°.

180°

### Appuyez simultanément

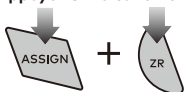

La LED de programmation (gauche) va clignoter bleu pendant 3 secondes.

270°

### Appuyez simultanément

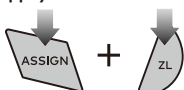

La LED de programmation (gauche) va clignoter vert pendant 3 secondes.

## Réglage de la sensibilité

La sensibilité du volant peut être réglée sur 7 niveaux.

La LED (Gauche) de programmation va changer de couleur pour indiquer le niveau de sensibilité.

Base du volant

### Appuyez pendant 3 secondes

①



La LED (Droit) de programmation va clignoter (lentement).

Appuyez

②



La LED (Droit) de programmation va clignoter (rapidement).

### Réglez le commutateur sur LS

③



La couleur de la LED (Gauche) va changer pour indiquer quel angle de rotation est sélectionné.

Appuyez

④



La valeur de la sensibilité augmente en pressant "haut" sur la croix directionnelle.

Sensible →

⑤



La valeur de la sensibilité baisse en pressant "bas" sur la croix directionnelle.

← Résistant

Appuyez  
Appuyez

⑥



La LED (Gauche) de programmation va s'éteindre.

La LED (Droit) de programmation va s'éteindre.

(La LED ASSIGN va s'allumer en vert lors de la configuration des boutons.)

- Si l'étape ③ n'est pas initiée après l'étape ②, la LED « ASSIGN » va s'éteindre après 4 secondes et le mode de configuration sera automatiquement arrêté.
- Entre les étapes 2~4, seulement la base du volant et les pédales peuvent être utilisés. Les autres boutons du volant vers la Nintendo Switch™ seront désactivés.
- Les réglages seront sauvegardés même si le câble USB est déconnecté.



	1	2	3	4	5	6	7
Couleur LED	Vert	Jaune	Rouge	Pourpre	Bleu	Bleu clair	Blanc

## ■ Réglage de la zone morte

La zone morte du centre du volant est paramétrable selon 7 niveaux.

La LED (Gauche) de programmation va changer de couleur pour indiquer la valeur de la zone morte.

### Appuyez pendant 3 secondes

①  **Appuyez**

La LED (Droit) de programmation va clignoter (lentement).

②  **Appuyez**

La LED (Droit) de programmation va clignoter (rapidement).

**Réglez le commutateur sur DP**

③  **Appuyez**

La couleur de la LED (Gauche) va changer pour indiquer quel angle de rotation est sélectionné.

④  **Appuyez**

La valeur de la sensibilité augmente en pressant "haut" sur la croix directionnelle. → Ample

⑤  **Appuyez**

La valeur de la sensibilité baisse en pressant "bas" sur la croix directionnelle. ← Réduit

⑥  **Appuyez**

La LED (Gauche) de programmation va s'éteindre.      La LED (Droit) de programmation va s'éteindre.  
(La LED ASSIGN va s'allumer en vert lors de la configuration des boutons.)

- Si l'étape ③ n'est pas initiée après l'étape ②, la LED « ASSIGN » va s'éteindre après 4 secondes et le mode de configuration sera automatiquement arrêté.
- Entre les étapes 2~4, seulement la base du volant et les pédales peuvent être utilisés. Les autres boutons du volant vers la Nintendo Switch™ seront désactivés.
- Les réglages seront sauvegardés même si le câble USB est déconnecté.

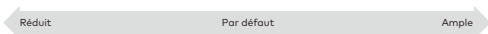

	1	2	3	4	5	6	7
Couleur LED	Vert	Jaune	Rouge	Pourpre	Bleu	Bleu clair	Blanc







## ■ Réinitialiser les paramètres par défaut

Pour restaurer les paramètres suivants en même temps : Mode Steering · Ajustement de la zone morte · Ajustement de la linéarité.

### Appuyez pendant 3 secondes

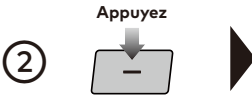
- 

1   La LED (Droit) de programmation va clignoter (lentement).
- 

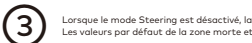
2 **Appuyez**   La LED (Gauche) de programmation va s'éteindre. La LED (Droit) de programmation va s'éteindre.  
(La LED ASSIGN va s'allumer en vert lors de la configuration des boutons.)
- 

3 Lorsque le mode Steering est désactivé, la valeur du volant sera rétablie par défaut à 270°. Les valeurs par défaut de la zone morte et de la linéarité sont de 4°.

· Si l'étape ③ n'est pas initiée après l'étape ②, la LED « ASSIGN » va s'éteindre après 4 secondes et le mode de configuration sera automatiquement arrêté.

## ■ Attention

- Ne jamais démonter, réparer ou modifier le produit.
- Gardez la manette à l'écart des zones poussiéreuses ou humides.
- Ne pas exercer de forte pression ou de choc sur le produit.
- Ne tirez pas et ne pliez pas le câble de la manette.
- Pour nettoyer le produit, merci d'utiliser un chiffon sec et doux.
- Ne jamais utiliser de produits chimiques tels que du benzène ou du diluant.
- Conserver ce produit hors de portée des enfants de moins de 3 ans.

## ■ Caractéristiques principales

### Base du volant

Dimensions externes : 280 × 275 × 286mm

Diamètre de direction : 280mm

Poids : 1400g

Angle de rotation : 270°

Longueur du câble : 3m

### Pédales

Dimensions externes : 234 × 305 × 180mm

Poids : 700g

Longueur du câble : 1.5m

**Remarque :**

Cet appareil obéit à la partie 15 du règlement de la FCC. Son fonctionnement est sujet à deux conditions:

(1) L'appareil ne doit pas causer d'interférences nuisibles, et (2) cet appareil doit tolérer les interférences reçues, ce qui inclut les interférences qui risquent de provoquer une utilisation indésirable.

**Remarque :**

cet équipement a été testé et déclaré conforme aux limites imposées aux appareils numériques de la classe B, en vertu de la partie 15 des règles de la FCC. Ces limites sont conçues pour assurer une protection suffisante contre les interférences nuisibles dans les installations résidentielles.

Cet équipement génère, utilise et peut dégager de l'énergie de radiofréquence et, s'il n'est pas installé et utilisé conformément aux instructions du fabricant, provoquer d'interférences préjudiciables aux communications radio.

Il n'existe toutefois aucune garantie qu'un équipement particulier ne souffrira pas d'interférences.

Si cet équipement entraîne des interférences préjudiciables à la réception des émissions radio ou de télévision, identifiables en mettant l'appareil hors tension, puis sous tension, il est recommandé que l'utilisateur tente de résoudre ce problème au moyen d'une ou plusieurs des mesures suivantes :

- en orientant l'antenne réceptrice différemment ou en la changeant de place

**INFORMATIONS SUR LA DESTRUCTION DU PRODUIT**

Le symbole ci-dessus signifie que, conformément aux lois et réglementations locales, vous devez mettre au rebut votre produit et/ou sa batterie séparément des ordures ménagères. Lorsque ce produit n'est plus utilisable, portez-le dans un centre de collecte des déchets agréé par les autorités locales. La collecte et le recyclage séparé de votre produit et/ou de sa batterie lors de l'élimination permettent de préserver les ressources naturelles et de protéger l'environnement et la santé des êtres humains.

Applicable seulement aux pays de l'UE.



EU et Turquie  
uniquement

**US**

**Garantie**

HORI garantie à l'acheteur original que le produit acheté neuf dans son emballage original est sans défaut matériel ni de production et cette garantie pour une période de 90 jours à partir de la date d'achat originale. Si votre demande de garantie ne peut être prise en charge par votre revendeur veuillez vous adresser directement à Hori: [infous@hori.jp](mailto:infous@hori.jp).

S'il vous plaît visitez <http://stores.horiusa.com/policies/> pour les détails de la garantie.

**EU**

**Garantie**

Pour toute demande de garantie dans les 30 jours après achat, veuillez en référer auprès de votre revendeur où le produit a été acheté originellement. Si votre demande de garantie ne peut pas être prise en charge par votre revendeur, ou pour toutes autres questions sur nos produits, veuillez vous adresser directement à Hori: [infoeu@hori.jp](mailto:infoeu@hori.jp).

L'image sur l'emballage peut différer du produit réel.

Le fabricant se réserve le droit de changer le design du produit ou ses caractéristiques techniques sans préavis.

Veuillez ne pas insérer les câbles dans les prises de courant.

L'emballage doit être conservé car il contient des informations importantes.

HORI et le logo de HORI sont des marques déposées de HORI.



Fabriqué en Chine

# Bedienungsanleitung

Vielen Dank, dass Sie sich für dieses Produkt entschieden haben.  
Bevor Sie dieses Produkt verwenden, lesen Sie bitte die Bedienungsanleitung sorgfältig durch.  
Heben Sie die Bedienungsanleitung zu Ihrer Information auf.

## Inhalt

Verbinden	20
Verpackungsinhalt	20
Systeminformationen	20
Bezeichnung der Teile	21
Anbringung	22
Steuerkreuzmodus-Schalter	22
Tastenthaltefunktion	22
Zuweisen Modus	23
Quick-Steuermodus	24
Justierung der Lenkradempfindlichkeit	24
Konfigurieren der "Dead Zone"	25
Zurücksetzen aller Konfigurationen	26
Warnhinweise	26
Hauptspezifikationen	26

## ■ Verbinden

- Verbinden Sie den Modularstecker des Fußpedal mit der Modularechnittstelle des Lenkrades.
- Dieses Produkt kann ohne das Fußpedal benutzt werden.

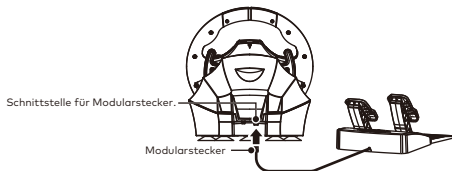

\* Dieses Produkt ist kein Drahtlos-Controller.

Drehen Sie das Steuerrad einmal in beide Richtungen bis zum maximalen Rotationswinkel.

• Bitte wiederholen Sie den Vorgang, wenn Sie den Controller erneut einstecken oder das Nintendo Switch™ oder PC System neustarten.

Drücken Sie beide Pedale einmal kräftig durch. • Sie können jetzt spielen!

• Bitte wiederholen Sie den Vorgang, wenn Sie den Controller erneut einstecken oder das Nintendo Switch™ oder PC System neustarten.

## ■ Verpackungsinhalt



Lenkrad



Fußpedale



Saugnäpfe



Klammer



Schraube



Bedienungsanleitung

## ■ Systeminformationen

### Nintendo Switch™ / PC(Xinput)

\* Fungiert als PC-Controller über Xinput. Dieses Produkt unterstützt kein DirectInput.

Unterstützte Betriebssysteme	Windows®10 / 8 ~ 8.1 / 7
Systemvoraussetzungen	USB-Anschluss, Internetverbindung

#### Wichtig

Stellen Sie sicher, dass Ihre Nintendo Switch™ mit der neuesten Firmware up to date ist.

## ■ Bezeichnung der Teile

### Lenkrad (Vorderansicht)

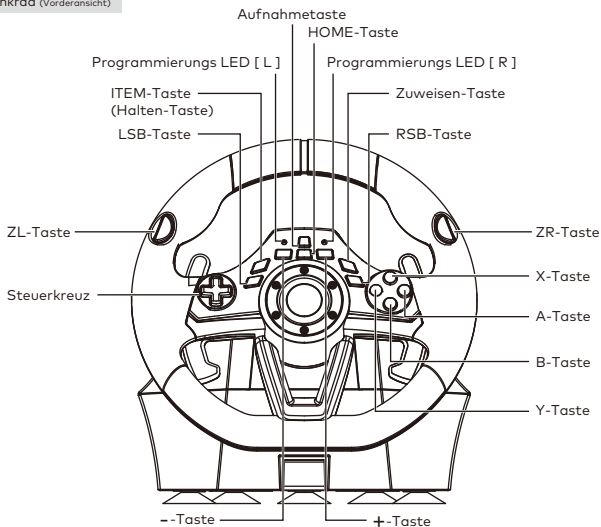

### Lenkrad (Rückseite)

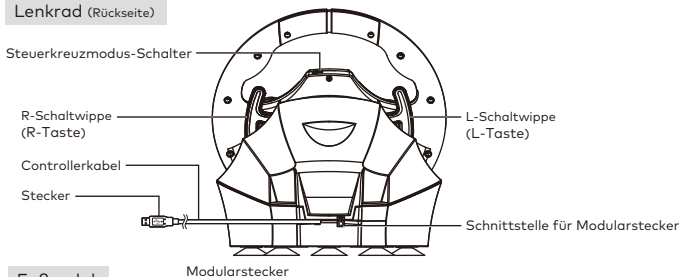

### Fußpedal

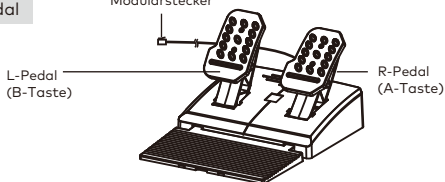

## ■ Anbringung

### Steuerrad

#### 1. Option: Saugnäpfe

- ① Bitte entfernen Sie Schmutz und Staub bevor Sie die fünf Saugnäpfe benutzen, um den Controller auf einem Tisch sicher zu befestigen.
- ② Bringen Sie die Saugnäpfe am Steuerrad an.

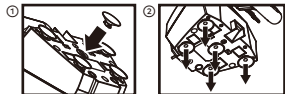

- Kombinieren Sie nicht beide Befestigungsmethoden, da die Saugnäpfe beschädigt werden könnten.
- Die Klammer nicht an Glas oder aus anderem zerbrechlichen Material gefertigte Möbel anbringen.
- Entfernen Sie das Produkt vorsichtig vom Möbel, um Schäden am Möbel oder Produkt zu vermeiden.

#### 2. Option: Klammer

- ① Drehen Sie die Schraube an der Klammer in die Basis des Steuerrades.
- ② Befestigen Sie das Steuerrad mit der Klammer an einer flachen und harten Oberfläche (Bspw. an einem Tisch).



### Fußpedale

Bitte stellen Sie die Fußpedale auf eine ebene Fläche.



## ■ Steuerkreuzmodus-Schalter

Die Funktion des Steuerkreuzes kann zwischen linkem Analogstick, rechtem Analogstick und Steuerkreuz umgeschaltet werden. Die Steuerkreuz Zuweisung ist nicht für jede Software gewährleistet.

- Bitte beachten Sie die Anleitung der Software. Das Produkt ist nicht Analog-Modus kompatibel.



## ■ Tastenhaltefunktion

Wenn Sie die Halten-Taste lang drücken, wird auch beim Loslassen der zugewiesenen Taste ein durchgehendes Halten der Taste simuliert.

### Aktivieren

1 Sekunde lang drücken



LED-Indikator beginnt rot zu leuchten.

### Deaktivieren

Einmal drücken



Rote LED erlischt.

ZL-Taste / ITEM-Taste / L-Schaltwippe

Tastenhaltefunktion ist deaktiviert solange andere Tasten der ITEM-Taste zugewiesen sind.

## WARNHINWEISE Beim Spielen von Mario Kart

Wenn die Tastenhaltefunktion aktiviert ist: Möchten Sie ein Item das Sie aufgenommen haben direkt nutzen, drücken Sie entweder die ZL-Taste/ITEM-Taste/L-Taste um die Tastenhaltefunktion zu deaktivieren.

Drücken Sie dann die Taste erneut um das Item zu benutzen.

Mit dieser Funktion können Sie Tasten neu belegen.

Programmierbare Tasten

ZL / ZR / LSB / RSB / ITEM / L-Schaltwippe / R-Schaltwippe / L-Pedal / R-Pedal

Zuweisbare Funktionen

A / B / X / Y / L / R / ZL / ZR / LSB / RSB / ITEM / L-Schaltwippe / R-Schaltwippe / Steuerkreuz (Rechts / Unten / Links / Oben) / Linker Joystick (Rechts / Unten / Links / Oben) / Rechter Joystick (Rechts / Unten / Links / Oben)

### 3 Sekunden lang drücken

Anpassung

①



Zuweisen-Taste



LED-Indikator blinkt langsam grün.

Drücken Sie die zu programmierende Taste

②



ZL / ZR / LSB / RSB / ITEM / L-Schaltwippe / R-Schaltwippe / L-Pedal / R-Pedal



LED-Indikator blinkt schnell grün.

Drücken Sie die die Funktion die Sie zuweisen wollen

③



oder



A / B / X / Y / L / R / ZL / ZR / LSB / RSB / ITEM / L-Schaltwippe / R-Schaltwippe /

Steuerkreuz / Linker Joystick / Rechter Joystick

- Drücken Sie die jeweilige Richtung (rechts, unten, links, oben) um die gewünschte Funktion zuzuweisen.



LED-Indikator beginnt grün zu leuchten.

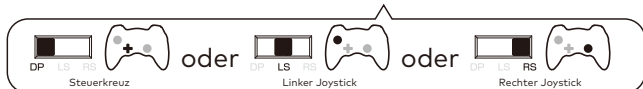

- Wenn Sie nach dem Ausführen von Schritt ① Schritt ② nicht ausführen, wird die Programm-LED nach vier Sekunden erlöschen und der Zuweisen-Modus wird automatisch beendet.
- Während Schritt 2 – 4 sind die Tasten des Controllers deaktiviert.
- Das Leuchten der Programm-LED (Links) zeigt an, dass eine Taste neu zugewiesen wurde. Die LED geht erst aus wenn alle Tasten auf Standardeinstellungen zurückgesetzt wurden.
- Wenn Sie eine Tastenfunktion deaktivieren wollen, halten Sie in Schritt 3 für 3 Sekunden die gleiche Taste gedrückt wie in Schritt 2.
- Falls Sie in Schritt 3 mehrere Tasten gedrückt haben wird die zuletzt gedrückte Taste zugewiesen.
- Die Einstellungen werden auch nach dem Trennen der USB-Verbindung weiter gespeichert.

### Zurücksetzen einzelner Tasten

Nutzen Sie die oben beschriebenen Schritte um Tasten individuell zurückzusetzen.

### Zurücksetzen aller Tasten / Funktion auf Standardeinstellungen

### 3 Sekunden lang drücken

①



Zuweisen-Taste



LED-Indikator blinkt langsam grün.

Drücken Sie den HOME-Knopf

②



Programm-LED erlischt und alle Tastenzuweisungen werden auf die Standardeinstellungen zurückgesetzt.

## Quick-Steuermodus

Für präziseres Steuern können Sie den maximalen Lenkradeinschlag von 270 Grad auf 180 Grad verringern.

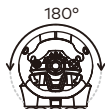

180°

### Gleichzeitig drücken

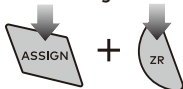

Programm LED (Links) leuchtet blau für 3 Sekunden.

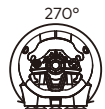

270°

### Gleichzeitig drücken

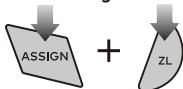

Programm LED (Links) leuchtet grün für 3 Sekunden.

## Justierung der Lenkradempfindlichkeit

Die Empfindlichkeit des Lenkrads kann in 7 Stufen angepasst werden. Die Programm-LED (Links) ändert die Farbe mit der Empfindlichkeit.

Lenkrad

### 3 Sekunden lang drücken



Drücken



### Stellen Sie die Stickmodus-Wechselschalter auf LS



Drücken



Drücken  
Drücken





- Wenn Sie nach dem Ausführen von Schritt ① Schritt ② nicht ausführen, wird die Programm-LED nach vier Sekunden erlöschen und der Zuweisen-Modus wird automatisch beendet.
- Während Schritt 2 – 4 sind die Tasten des Controllers deaktiviert. Nur Eingaben des Lenkrades und der Fusspedale werden registriert.
- Die Einstellungen bleiben erhalten, unabhängig von der USB-Verbindung.

← Abgestuft (Einfaches Steuern)                      Standard                      Empfindlich (Einfach zu drehen) →

	1	2	3	4	5	6	7
LED-Farbe	Grün	Gelb	Rot	Lila	Blau	Hellblau	Weiß

## ■ Konfigurierbare "Dead Zone"

Die Dead Zone des Lenkrades kann in 7 Stufen angepasst werden.  
Die Programm-LED (Links) wechselt die Farbe mit der Dead Zone Einstellung.

### 3 Sekunden lang drücken



### Stellen Sie die Stickmodus-Wechselschalter auf DP

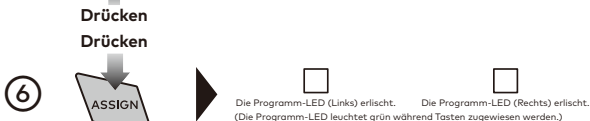
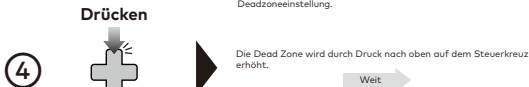

- Wenn Sie nach dem Ausführen von Schritt ① Schritt ② nicht ausführen, wird die Programm-LED nach vier Sekunden erlöschen und der Zuweisen-Modus wird automatisch beendet.
- Während Schritt 2 – 4 sind die Tasten des Controllers der Nintendo Switch™ deaktiviert. Nur Eingaben des Lenkrades und der Fusspedale werden registriert.
- Die Einstellungen bleiben erhalten, unabhängig von der USB-Verbindung.

← Schmal                      Standard                      Weit →

	1	2	3	4	5	6	7
LED-Farbe	Grün	Gelb	Rot	Lila	Blau	Hellblau	Weiss

## ■ Zurücksetzen aller Konfigurationen

Alle folgenden Einstellungen : Quick-Steuermodus · "Dead Zone" - Einstellung · Empfindlichkeitseinstellung zurücksetzen.

### 3 Sekunden lang drücken

1



Die Programm-LED (Rechts) blinkt (langsam).

2



Die Programm-LED (Links) erlischt.



Die Programm-LED (Rechts) erlischt.

(Die Programm-LED leuchtet grün während Tasten zugewiesen werden.)

3

Wenn der Quick-Steuermodus abgeschaltet wird, wird der Drehwinkel auf 270° zurückgesetzt. Deadzone und Empfindlichkeit werden auf die Grundeinstellung "4" zurückgesetzt.

· Falls Sie Schritt ② nicht nach ① ausführen, erlöscht das Zuweisen LED nach 4 Sekunden und der Tastenprogrammiermodus wird beendet.

## ■ Warnhinweise

- Bauen Sie dieses Produkt nicht auseinander, versuchen Sie nicht es zu reparieren oder zu modifizieren.
- Halten Sie den Controller von staubigen und feuchten Umgebungen fern.
- Setzen Sie das Produkt keiner starken Druck- oder Gewichtsbelastung aus.
- Reißen oder biegen Sie das Controllerkabel nicht.
- Falls das Produkt gereinigt werden muss, verwenden Sie lediglich ein weiches, trockenes Tuch.
- Verwenden Sie keine chemischen Reinigungsmittel wie Benzine oder Verdünnungsmittel.
- Bewahren Sie dieses Produkt außerhalb der Reichweite von Kindern unter 3 Jahren auf.

## ■ Hauptspezifikationen

### Lenkrad

Dimensionen : 280 × 275 × 286mm

Lenkraddurchmesser : 280mm

Gewicht : 1400g

Rotationswinkel : 270°

Kabellänge : 3m

### Fußpedale

Dimensionen : 234 × 305 × 180mm

Gewicht : 700g

Kabellänge : 1.5m

## INFORMATIONEN ZUR ENTSORGUNG

Falls Sie das nebenstehende Symbol auf einem unserer elektronischen Produkte oder deren Verpackung sehen, bedeutet das, dass dieses Produkt in Europa nicht mit dem Hausmüll entsorgt werden darf. Um das Produkt und Batterien korrekt zu entsorgen, informieren Sie sich bitte über die lokalen Gesetze und Regulierungen zur Entsorgung von elektronischen Geräten und Batterien. Dadurch helfen Sie mit natürliche Ressourcen zu schonen und den Umgang mit elektronischem Abfall zu verbessern. Gilt nur für EU-Länder.



Nur EU und Türkei

### US

#### Garantie

Für 90 Tage nach dem ursprünglichen Kaufdatum garantiert HORI dem ursprünglichen Käufer, dass das neu und in Originalverpackung gekaufte Produkt frei von jeglichen Mängeln in Material und Verarbeitung ist. Falls der Garantieanspruch nicht über den ursprünglichen Verkäufer abgewickelt werden kann, kontaktieren Sie HORI bitte direkt unter [infous@hori.jp](mailto:infous@hori.jp).

Bitte besuchen Sie <http://stores.horiusa.com/policies/> für Details zur Garantie.

### EU

#### Garantie

Für alle Gewährleistungsansprüche innerhalb der ersten 30 Tage nach dem Kauf, wenden Sie sich bitte an den Händler, bei dem der ursprüngliche Kauf stattgefunden hat. Wenn der Garantieanspruch nicht durch den Fachhändler geleistet wird oder Sie eine andere Frage haben, wenden Sie sich bitte direkt an HORI durch [infoeu@hori.jp](mailto:infoeu@hori.jp).

Bilder und Darstellungen auf der Verpackung können vom tatsächlichen Produkt abweichen. Der Hersteller behält sich das Recht vor, die Spezifikation des Produktes ohne Warnung zu ändern. Kabel nicht in eine Steckdose stecken.

Die Verpackung muss aufgehoben werden, da sie wichtige Informationen enthält.

HORI und das HORI-Logo sind eingetragene Warenzeichen von HORI.



Hergestellt in China

# Manuale di istruzioni

Grazie per aver scelto questo prodotto.

Prima di utilizzarlo, leggere attentamente le istruzioni.

Una volta lette le istruzioni, conservarle per riferimenti futuri.

## Indice

Come collegare il prodotto	29
Contenuto	29
Piattaforma	29
Nomi dei componenti	30
Opzioni di fissaggio	31
Interruttore di controllo del Pad Direzionale	31
Funzione Button Hold	31
Modalità Assegna	32
Modalità Guida veloce	33
Sensibilità regolabile	33
Dead Zone regolabile	34
Ripristinare tutte le funzioni	35
Attenzione	35
Specifiche tecniche	35

## ■ Come collegare il prodotto

- Connettere la spina modulare del pedale alla relativa porta di connessione dietro al Volante.
- Questo prodotto può essere utilizzato anche senza pedaliera.

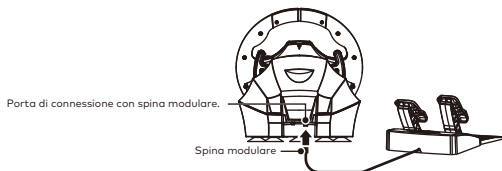

\* Questo prodotto non è un controller wireless.

Ruotare il volante nella posizione di massima rotazione una volta a destra e sinistra.

Premere entrambi i pedali (destra e sinistra) una volta. A questo punto tutto è pronto per giocare!

- Ripetere l'operazione se si deve reinserire il controller o se si deve riavviare la Nintendo Switch™ o PC.

## ■ Contenuto



Volante



Pedali



Ventose



Morsetto



Vite



Manuale di istruzioni

## ■ Piattaforma

### Nintendo Switch™ / PC(Xinput)

\* Funziona come controller PC tramite Xinput.  
Questo prodotto non supporta DirectInput.

Sistemi supportati	Windows®10 / 8~8.1 / 7
Requisiti di sistema	Porta USB, Connessione Internet

#### Importante

Assicurati che la tua Nintendo Switch™ sia aggiornata all'ultima versione del software di sistema.

## ■ Nomi dei componenti

### Volante (Vista frontale)

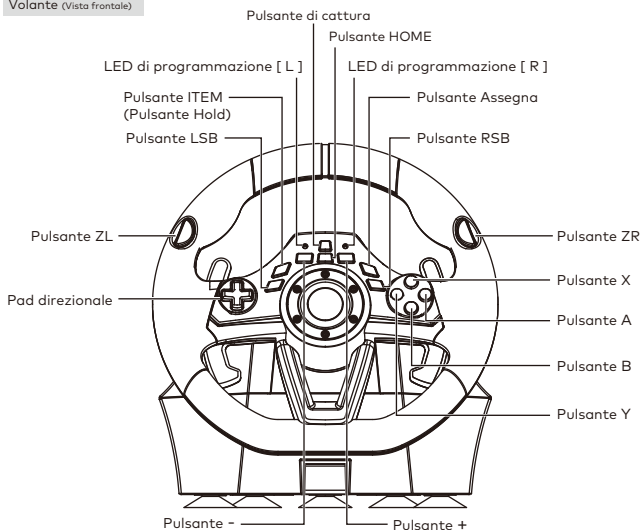

### Volante (Vista posteriore)

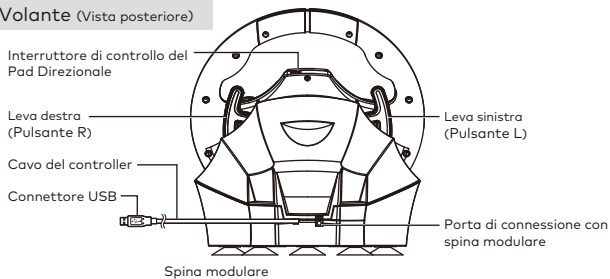

### Pedali

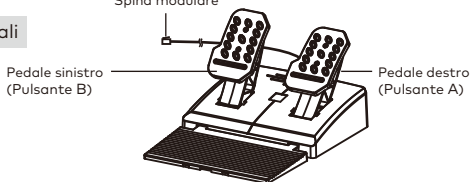

## Opzioni di fissaggio

### Volante

Opzione 1: ventose

- 1 Rimuovere polvere e sporco prima di utilizzare le 5 ventose per fissare il controller alla superficie di un tavolo.
- 2 Attaccare le ventose correttamente alla base del volante.



Opzione 2 : morsetto

- 1 Serrare la vite di fissaggio di base del volante.
- 2 Utilizzare il morsetto per fissare l'unità di sterzo ad una superficie dura piatta.



- Non utilizzare entrambi i metodi di fissaggio in quanto le ventose potrebbero danneggiarsi.
- Non utilizzare su mobili di vetro o altri materiali fragili.
- Al momento della rimozione del prodotto, staccare con attenzione per evitare danni ai mobili o al prodotto.

### Pedali

Utilizzare i pedali mettendoli su una superficie piana.



## Interruttore di controllo del Pad Direzionale

Il Pad direzionale può essere configurato come tale o come joystick analogico destro/sinistro.

Non è garantito il funzionamento di questa funzione con tutti i software.

- Si prega di fare riferimento al libretto di istruzioni del software. Questo prodotto non funziona con la modalità analogica.



Pad direzionale



Levetta analogica sinistra



Levetta analogica destra

## Funzione Button Hold

Tenendo premuto il pulsante Hold è possibile mantenere attiva e ripetere la funzione di un pulsante senza doverlo premere.

### Attivazione

Premere per 1 secondo



### Disattivazione

Premere una volta



Pulsante ZL / Pulsante ITEM / Leva sinistra

Nel caso in cui al pulsante ITEM sia stata assegnata un'altra funzione pulsante, la modalità Button Hold sarà disattivata.

## Attenzione Quando si gioca con Mario Kart

Se la modalità Button Hold è attiva, per utilizzare un oggetto raccolto premere uno qualsiasi tra i pulsanti ZL / ITEM / L e la modalità Turbo Hold verrà disattivata. Dunque premere il pulsante una seconda volta per utilizzare l'oggetto.

È possibile riconfigurare le funzioni dei pulsanti utilizzando questa funzionalità.

**Pulsanti programmabili**

ZL / ZR / LSB / RSB / ITEM / Leva sinistra / Leva destra / Pedale sinistro / Pedale destro

**Funzioni assegnabili**

A / B / X / Y / L / R / ZL / ZR / LSB / RSB / ITEM / Leva sinistra / Leva destra / Pad direzionale (Destra / Giù / Sinistra / Su) / Levetta analogica sinistra (Destra / Giù / Sinistra / Su) / Levetta analogica destra (Destra / Giù / Sinistra / Su)

**Come assegnare**

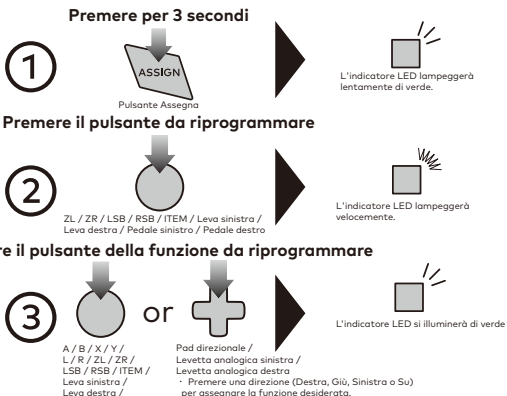

- Dopo 4 secondi di inattività tra i passaggi, il LED di programma (Destra) si spegne e la modalità di assegnazione funzione si arresta.
- Durante il passaggio 2, l'input pulsanti dal volante alla PlayStation 4 sarà disattivato.
- Quando il LED di programma (Sinistra) si accende, è indicazione che un pulsante è stato rimappato ed esso non si spegnerà fino a quando la funzione del pulsante non verrà riportata al suo valore predefinito.
- Se si desidera disabilitare la funzione di un pulsante, premere e tenere premuto per 3 secondi lo stesso pulsante premuto al passaggio 2 al momento del passaggio 3.
- Se vengono premuti più pulsanti durante il passaggio 3, verrà assegnato solamente l'ultimo pulsante premuto.
- Le funzioni impostate rimangono attive anche se il cavo USB del volante viene scollegato dalla console.

**Come ripristinare un singolo pulsante**

Seguire il passaggio 3 descritto sopra per riportare un singolo pulsante alla funzione predefinita.

**Come ripristinare tutti i pulsanti / tutte le funzioni**

**Premere per 3 secondi**



**Premere il pulsante HOME**





## ■ Modalità Guida veloce

Si può godere di una esperienza di guida più veloce portando l'angolo massimo di rotazione da 270° a 180°.

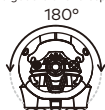

### Premere contemporaneamente

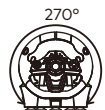
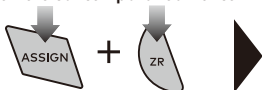

### Premere contemporaneamente

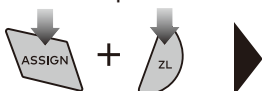

## ■ Sensibilità regolabile

La sensibilità del volante è regolabile su sette livelli.  
Il colore del LED sinistro cambierà per indicare il valore di sensibilità.

Volante

### Premere per 3 secondi



### Impostare l'interruttore di controllo del Pad Direzionale su "LS"



- Se lo step ③ non viene eseguito entro 4 secondi dallo step ②, il LED si spegne e la riconfigurazione delle funzioni termina automaticamente.
- Durante gli step 2~4, solo le unità di sterzo e di ingresso pedali sono abilitate. Le funzioni di input pulsanti dal controller alla Nintendo Switch™ saranno disattivate.
- Le funzioni impostate rimangono attive anche se il cavo USB del volante viene scollegato dalla console.



	1	2	3	4	5	6	7
Colore del LED	Verde	Giallo	Rosso	Viola	Blu	Azzurro	Bianco

## ■ Dead Zone regolabile

La Dead Zone del volante è regolabile su sette livelli. Il LED di configurazione (sinistro) cambierà colore in base al valore della dead zone selezionato.

### Premere per 3 secondi

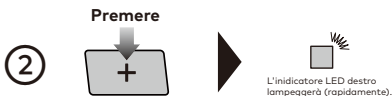

### Impostare l'interruttore di controllo del Pad Direzionale su "DP"



Premere



Premere

Premere



- Se lo step ⑥ non viene eseguito entro 4 secondi dallo step ⑤, il LED si spegne e la riconfigurazione delle funzioni termina automaticamente.
- Durante gli step 2~4, solo le unità di sterzo e di ingresso pedali sono abilitate. Le funzioni di input pulsanti dal controller alla Nintendo Switch™ saranno disattivate.
- Le funzioni impostate rimangono attive anche se il cavo USB del volante viene scollegato dalla console.







	1	2	3	4	5	6	7
Colore del LED	Verde	Giallo	Rosso	Viola	Blu	Azzurro	Bianco





## ■ Ripristinare tutte le funzioni

Per ripristinare tutto in una sola volta: Modalità di Guida Veloce · Regolazione della Dead Zone · Regolazione della Sensibilità.

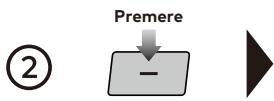
### Premere per 3 secondi

- 

1     
L'indicatore LED destro lampeggerà (lentamente).
- 

2 **Premere**  
     
L'indicatore LED sinistro si spegne. L'indicatore LED destro si spegne.  
(Il LED diventa verde quando si riconfigurano le funzioni dei pulsanti.)
- 

3 Abbandonando la Modalità di Guida Veloce, il volante riacquista il suo angolo di sterzata predefinito (270 gradi). Il valore predefinito della Dead Zone e della sensibilità è "4".

• Se lo step ③ non viene eseguito entro 4 secondi dallo step ②, il LED si spegne e la riconfigurazione delle funzioni termina automaticamente.

## ■ Attenzione

- Non smontare, riparare o modificare questo prodotto.
- Tenere il controller lontano da polvere e umidità.
- Non sottoporre il prodotto ad urti o pesi.
- Non tirare con forza o piegare il cavo del controller.
- In caso di pulizia, usare unicamente un panno asciutto. Non usare agenti chimici come benzene o diluenti.
- Tenere questo prodotto fuori dalla portata dei bambini al di sotto dei 3 anni.

## ■ Specifiche tecniche

### Volante

Dimensioni	: 280 × 275 × 286mm
Diametro	: 280mm
Peso	: 1400g
Angolo di rotazione	: 270°
Lunghezza del cavo	: 3m

### Pedale

Dimensioni	: 234 × 305 × 180mm
Peso	: 700g
Lunghezza del cavo	: 1.5m

## INFORMAZIONI PER LO SMALTIMENTO DEL PRODOTTO

Se trovate questo simbolo su uno dei nostri prodotti o imballaggi, significa che il prodotto o la batteria non devono essere trattati come rifiuti domestici in Europa. Per garantire un trattamento adeguato dei rifiuti per il prodotto o la batteria, smaltirlo in conformità alla normativa in vigore nel vostro luogo di residenza in relazione al trattamento di apparecchi elettrici e batterie. In questo modo si contribuisce a preservare le risorse naturali e migliorare gli standard di protezione ambientale riguardanti il trattamento e il riciclaggio dei rifiuti elettrici. Questo vale solo per i paesi dell'UE.



Solo per UE  
e Turchia

### US

#### Garanzia

HORI garantisce al compratore originale, durante un periodo di 90 giorni dal momento dell'acquisto, che questo prodotto, quando acquistato nuovo e nel suo imballaggio originale, è privo di qualsiasi difetto materiale o di fabbricazione.

Nel caso in cui la domanda di garanzia non potesse essere presa in carico dal negozio dove l'acquisto è avvenuto si prega di contattare direttamente HORI a [infous@hori.jp](mailto:infous@hori.jp).

Per maggiori informazioni sulla garanzia, visitare il nostro sito web:

<http://stores.horiusa.com/policies/>

### EU

#### GARANZIA

Per tutte le richieste di garanzia effettuate entro i primi 30 giorni dopo l'acquisto, si prega di rivolgersi al rivenditore presso il quale il primo acquisto è stato effettuato per i dettagli. Se la richiesta di garanzia non può essere elaborata dal rivenditore originale, così come per qualunque domanda circa il nostro catalogo, si prega di rivolgersi direttamente a HORI scrivendo a [infoeu@hori.jp](mailto:infoeu@hori.jp).

L'illustrazione mostrata può differire dal prodotto reale.

Il produttore riserva il diritto di modificare il design o le specifiche del prodotto senza preavviso.

Non tentare di collegare i cavi di questo prodotto a una presa elettrica.

Conserva l'imballo, in quanto contiene informazioni importanti.

HORI e il logo HORI sono marchi registrati di HORI.



Prodotto in Cina

# Manual de instrucciones

Gracias por haber elegido este producto.

Antes de usarlo, lee detenidamente el manual de instrucciones.

Una vez lo hayas hecho, recomendamos que lo guardes para futuras consultas.

## Índice

Modo de conexión	38
Contenido	38
Plataforma	38
Esquema	39
Modo de fijación	40
Interruptor de configuración de la cruceta	40
Función "Mantener pulsado"	40
Modo Assign	41
Modo Conducción rápida	42
Sensibilidad regulable	42
Zona muerta regulable	43
Cómo restaurar la configuración de fábrica	44
Atención	44
Características principales	44

## ■ Modo de conexión

- Conecta el enchufe modular de los pedales al puerto de conexión modular de la unidad del volante.
- Es posible utilizar este producto sin los pedales.

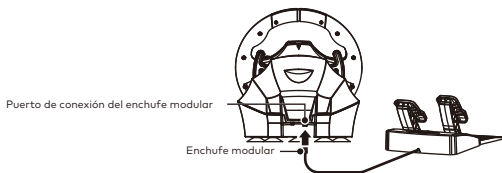

\* Este producto no es un controlador inalámbrico.

Gira el volante una vez al máximo en ambos sentidos. Pisa ambos pedales hasta el fondo. ¡Ya estás listo para jugar!

\* Repite el proceso cada vez que reconectes el controlador o reinicies el sistema Nintendo Switch™ o PC.

## ■ Contenido



Volante



Pedales



Ventosas



Abrazadera



Tornillo



Manual de instrucciones

## ■ Plataforma

### Nintendo Switch™/PC (Xinput)

\* Funciona como controlador de PC mediante XInput.  
Este producto no es compatible con DirectInput.

SO compatibles	Windows®10/8 - 8.1/7
Requisitos del sistema	Puerto USB, conexión a internet

#### Importante

Asegúrate de que la Nintendo Switch™ cuenta con la última versión del software del sistema.

Unidad del volante (vista frontal)

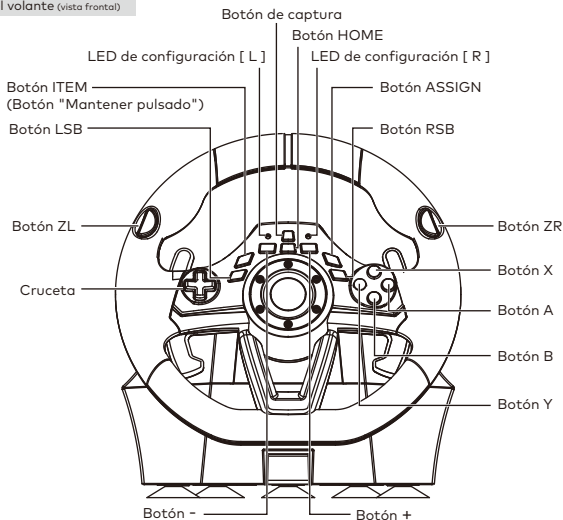

Unidad del volante (Vista trasera)

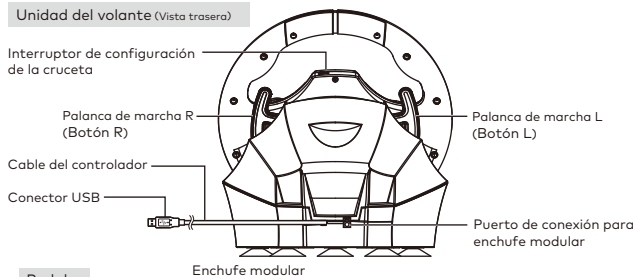

Pedales

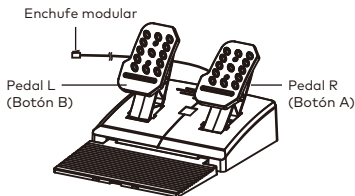

## ■ Modo de fijación

### Unidad del volante

#### Opción 1: Ventosas

- 1 Coloca las ventosas en la base de la unidad del volante.
- 2 Elimina cualquier resto de polvo o suciedad de la mesa antes de asegurar el controlador en ella mediante las cinco ventosas.



- No utilices ambos métodos de fijación a la vez, pues podrías dañar las ventosas.
- No utilices la abrazadera con muebles de cristal o materiales frágiles.
- Retira el producto del mueble utilizado teniendo cuidado de no dañar ninguno de los dos.

#### Opción 2: Abrazadera

- 1 Inserta del tornillo de la abrazadera en la base de la unidad del volante.
- 2 Utiliza la abrazadera para fijar la unidad del volante a una superficie lisa y resistente (por ejemplo, una mesa).



### Pedales

Coloca los pedales en una superficie lisa.



## ■ Interruptor de configuración de la cruzeta

La cruzeta se puede configurar para funcionar como stick izquierdo, stick derecho o como pad direccional. No se garantiza el correcto funcionamiento del interruptor de configuración de la cruzeta de este producto con cualquier juego.

- Consulta el manual de instrucciones de cada título. Este producto no funciona en modo analógico.



## ■ Función "Mantener pulsado"

Al apretar el botón "Mantener pulsado", se consigue el mismo resultado que si se mantuviese pulsado todo el rato el botón cuya función se le ha asignado.

### Activación

**Mantén pulsado durante 1 segundo**



### Desactivación

**Apretar una vez**



Botón ZL / Botón ITEM / Palanca de marcha L

En caso de que el botón ITEM tenga asignada la función de otro botón, la función "Mantener pulsado" no se activará al apretarlo.

## ATENCIÓN Al jugar a Mario Kart

Si la función "Mantener pulsado" está activada, para utilizar el objeto que hayas recogido, primero aprieta cualquiera de los siguientes botones para desactivarla: ZL / ITEM / leva izquierda. Luego pulsa de nuevo el botón para usar el objeto.



Esta característica permite configurar la función de los botones.

Botones programables

ZL / ZR / LSB / RSB / ITEM / Palanca de marcha L / Palanca de marcha R / Pedal L / Pedal R

Funciones asignables

A / B / X / Y / L / R / ZL / ZR / LSB / RSB / ITEM / Palanca de marcha L / Palanca de marcha R / Pad direccional (Derecha / Abajo / Izquierda / Arriba) / Stick izquierdo (Derecha / Abajo / Izquierda / Arriba) / Stick derecho (Derecha / Abajo / Izquierda / Arriba)

Modo de ajuste

Mantén pulsado durante 3 segundos

1



Botón ASSIGN



El indicador parpadeará lentamente en verde.

Pulsa Botones programables

2



ZL / ZR / LSB / RSB / ITEM / Palanca de marcha L / Palanca de marcha R / Pedal L / Pedal R



El indicador parpadeará rápidamente en verde.

Pulsa Funciones asignables

3



A / B / X / Y / L / R / ZL / ZR / LSB / RSB / ITEM / Palanca de marcha L / Palanca de marcha R



Pad direccional / Stick izquierdo / Stick derecho

- Pulsa la flecha de dirección (Derecha / Abajo / Izquierda / Arriba) para asignar la función deseada.



El indicador se encenderá en verde.



- Después de 4 segundos de inactividad entre un paso y el siguiente, el LED de configuración (derecho) se apagará y el proceso de configuración se cancelará automáticamente.
- Durante el paso 2, todos los botones del controlador dejarán de funcionar momentáneamente.
- El LED de configuración (izquierdo) se encenderá para indicar que un botón ha sido reconfigurado, y no se apagará hasta que no se asigne al botón su función original.
- Si pulsas más de un botón en el paso 3, la función asignada será la del último botón pulsado.
- Las nuevas funciones asignadas se conservarán incluso si se desconecta el controlador.

Cómo restaurar la configuración de fábrica de un botón

Sigue los pasos anteriores para devolver a un botón en concreto su función original.

Cómo restaurar la configuración de fábrica de todos los botones

Mantén pulsado durante 3 segundos

1



Botón ASSIGN



El indicador parpadeará lentamente en verde.

Pulsa Botón HOME

2



El LED de configuración (derecho) se apagará y todos los botones recuperarán sus funciones originales.

## ■ Modo Conducción rápida

Disfruta de una experiencia de conducción más rápida ajustando el ángulo de giro máximo de 270° a 180°.

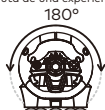

**Pulsa a la vez**

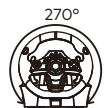

**Pulsa a la vez**

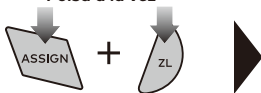

## ■ Sensibilidad regulable

Se puede regular la sensibilidad del volante a siete niveles distintos.

El LED de configuración (izquierdo) cambiará de color para indicar el valor seleccionado.

Unidad del volante

**Mantén pulsado durante 3 segundos**



- Si no inicias el paso ② una vez ejecutado el ①, el LED de ASSIGN se apagará al cabo de 4 segundos y el modo de configuración de botones se cancelará automáticamente.
- Durante los pasos 2-4, la Nintendo Switch™ solo se podrá controlar con el volante y los pedales. El mando de la consola quedará desactivado.
- Los ajustes se guardarán aunque el cable USB no esté conectado.

Baja (dirección estable)

Normal

Alta (maniobra rápida)

	1	2	3	4	5	6	7
Color del LED	Verde	Amarillo	Rojo	Morado	Azul	Azul claro	Blanco

## ■ Zona muerta regulable

La zona muerta en torno a la posición central del volante (la amplitud del movimiento que no provoca una respuesta) admite siete ajustes distintos. El LED de configuración (izquierdo) cambiará de color para indicar la amplitud de la zona muerta.

### Mantén pulsado durante 3 segundos

①



El LED de configuración (derecho) parpadeará (lentamente).

Pulsa

②



El LED de configuración (derecho) parpadeará (rápidamente).

### Coloca el interruptor de configuración de la cruzeta en posición «DP»

③



El LED de configuración (izquierdo) cambiará de color de acuerdo con la tabla inferior.

Pulsa

④



El valor de la zona muerta aumenta al pulsar la flecha superior de la cruzeta.

Amplia

⑤



El valor de la zona muerta disminuye al pulsar la flecha inferior de la cruzeta.

Estrecha

Pulsa

Pulsa

⑥



El LED de configuración (izquierdo) se apagará.



El LED de configuración (derecho) se apagará.

(El LED de ASSIGN se pondrá en verde al configurar botones).

- Si no inicias el paso ② una vez ejecutado el ③, el LED de ASSIGN se apagará al cabo de 4 segundos y el modo de configuración de botones se cancelará automáticamente.
- Durante los pasos 2-4, la Nintendo Switch™ solo se podrá controlar con el volante y los pedales. El mando de la consola quedará desactivado.
- Los ajustes se guardarán aunque el cable USB no esté conectado.

Estrecha

Normal

Amplia

	1	2	3	4	5	6	7
Color del LED	Verde	Amarillo	Rojo	Morado	Azul	Azul claro	Blanco

## ■ Cómo restaurar la configuración de fábrica

Para restaurar a la vez los siguientes parámetros: Modo Conducción rápida · Ajuste de la zona muerta · Ajuste de la linealidad.

### Mantén pulsado durante 3 segundos

1



 El LED de configuración (derecho) parpadeará (lentamente).

2

Pulsa



 El LED de configuración (izquierdo) se apagará.  
 El LED de configuración (derecho) se apagará.  
(El LED de ASSIGN se pondrá en verde al configurar botones).

3

Al salir del Modo Conducción rápida, el volante recuperará su ángulo de giro de fábrica (270°). El valor predeterminado de la zona muerta y la linealidad es "4".

· Si no inicias el paso ③ una vez ejecutado el ②, el LED de ASSIGN se apagará al cabo de 4 segundos y el modo de configuración de botones se cancelará automáticamente.

## ■ Atención

- No trates de desmontar, reparar o modificar este producto.
- Mantén el controlador alejado de zonas húmedas o con polvo.
- No ejerzas demasiada fuerza sobre el producto ni lo sometas a impactos.
- No tires bruscamente del cable del controlador ni lo retuerzas.
- Para limpiarlo, utiliza solo un paño suave y seco. No emplees agentes químicos como benceno o disolventes.
- Mantén este producto lejos del alcance de los niños menores de 3 años.

## ■ Características principales

### Unidad del volante

Dimensiones : 280 x 275 x 286 mm

Diámetro : 280 mm

Peso : 1400 g

Ángulo de rotación : 270°

Longitud del cable : 3 m

### Pedales

Dimensiones : 234 x 305 x 180 mm

Peso : 700 g

Longitud del cable : 1,5 m

#### CONFORMIDAD CON LA NORMATIVA DE LA FCC

Este dispositivo cumple con la Parte 15 del Reglamento de la FCC. Su funcionamiento está sujeto a las siguientes dos condiciones: (1) este dispositivo no puede causar interferencias perjudiciales, y (2) este dispositivo debe aceptar cualquier interferencia que reciba, incluyendo aquellas que puedan causar un funcionamiento no deseado.

#### CONFORMIDAD CON LA NORMATIVA DE LA FCC

Este equipo ha sido probado y cumple con los límites para un dispositivo digital de Clase B, de conformidad con la Parte 15 del Reglamento de la FCC. Estos límites están diseñados para proporcionar una protección razonable contra interferencias perjudiciales en una instalación residencial. Este equipo genera, utiliza y puede irradiar energía de radiofrecuencia y, si no se instala y utiliza de acuerdo con las instrucciones, puede causar interferencias perjudiciales a las comunicaciones de radio. Sin embargo, no hay garantía de que no se produzcan interferencias en una determinada instalación.

Si este equipo causa interferencias perjudiciales a radio o televisión, lo cual puede ser detectado apagando y encendiendo el equipo, se recomienda al usuario que intente solucionar la interferencia con una o más de las siguientes medidas:

- Reorientando o reubicando la antena receptora.
- Aumentando la separación entre el equipo y el receptor.

#### INFORMACIÓN PARA DESECHAR EL PRODUCTO

Si encuentras este símbolo en uno de nuestros productos o embalajes, significa que dicho producto o batería no debe tratarse como cualquier otro desecho doméstico en Europa. Para garantizar el tratamiento de residuos apropiado para dicho producto o batería, deséchalo respetando la legislación vigente en tu lugar de residencia en relación con el tratamiento de aparatos eléctricos y baterías. De este modo ayudarás a conservar los recursos naturales y mejorar los estándares de protección medioambiental relativos al tratamiento y reciclaje de residuos eléctricos. Esto se aplica solamente a países de la UE.



Solo en la UE  
y Turquía

#### US

##### Garantía

HORI garantiza al comprador original, durante un periodo de 90 días contados desde la fecha de compra, que este producto, cuando adquirido nuevo y en su embalaje original, estará libre de cualquier tipo de defecto de fabricación. En caso de no poder hacer valer la garantía a través del establecimiento de compra original, dirígete directamente a HORI: [infous@hori.jp](mailto:infous@hori.jp). Para más información, visita nuestro sitio web: <http://stores.horiusa.com/policies/>

#### EU

##### Garantía

Si surge cualquier incidencia relacionada con la garantía de este producto antes de transcurridos los primeros 30 días después de la compra, consulta con el comercio donde lo adquiriste. En caso de que dicho comercio no pueda aceptar la reclamación, así como para cualquier consulta sobre nuestro catálogo, dirígete directamente a [infoeu@hori.jp](mailto:infoeu@hori.jp).

El producto real puede variar con respecto a la ilustración.

El fabricante se reserva el derecho a modificar el diseño y características del producto sin previo aviso.

No intentes conectar los cables de este producto a una toma de corriente.

Conserva el embalaje, pues contiene información importante.

HORI y el logotipo de HORI son marcas comerciales registradas de HORI.



Fabricado en China

# Gebruikershandleiding

Bedankt voor het aanschaffen van dit product.  
Lees de instructies aandachtig voordat u dit product gebruikt.  
Bewaar de handleiding na het lezen ter referentie.

## Inhoudsopgave

Hoe verbinding te maken	47
Inbegrepen	47
Platform	47
Indeling	48
Hoe te monteren	49
Bedieningstuimelschakelaar	49
Knop Hold-functie	49
Modus toewijzen	50
Snelle verwerkingsmodus	51
Instelbare gevoeligheid	51
Instelbare Dode Zone	52
Reset terug naar standaardinstellingen	53
Let op	53
Hoofdspecificaties	53

## ■ Hoe verbinding te maken

- Zorg ervoor dat de richting van de modulaire stekker correct is voordat u deze aansluit.
- Dit product kan zonder de voetpedalen worden gebruikt.

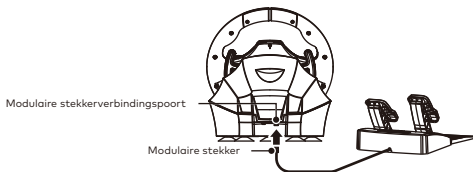

\* Dit product is geen draadloze controller.

Draai het stuurwiel eenmaal in de maximale rotatiepositie beide richtingen.

Druk eenmaal volledig in elk van het L-pedaal en R-pedaal.

Repeat Herhaal het proces wanneer u de controller opnieuw aansluit of start de Nintendo Switch™-systeem of PC.

## ■ Inbegrepen



Bestuureenheid



Voetpedalen



Zuignappen



Klem



Schroef



Handleiding

## ■ Platform

### Nintendo Switch™ / PC(Xinput)

\* Functies als pc-controller via Xinput.  
Dit product biedt geen ondersteuning voor DirectInput.

Ondersteund besturingssysteem	Windows®10 / 8~8.1 / 7
Systeem vereisten	USB-poort, internetverbinding

### Important

Zorg ervoor dat je Nintendo Switch™ is bijgewerkt met de nieuwste systeemsoftware.

Bestuurinrichting (vooraanzicht)

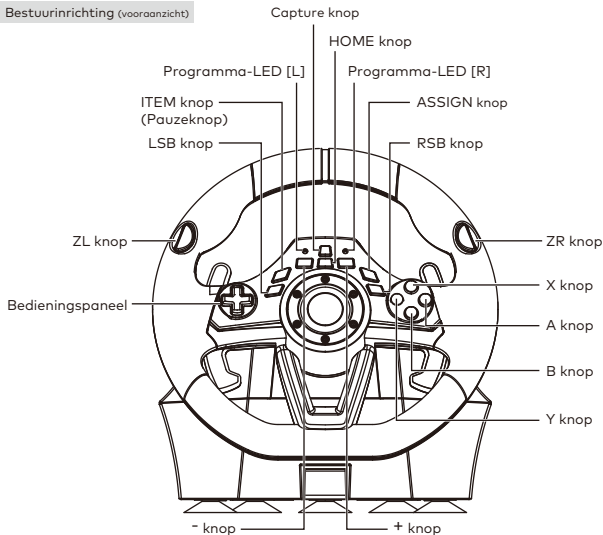

Stuureenheid (achteraanzicht)

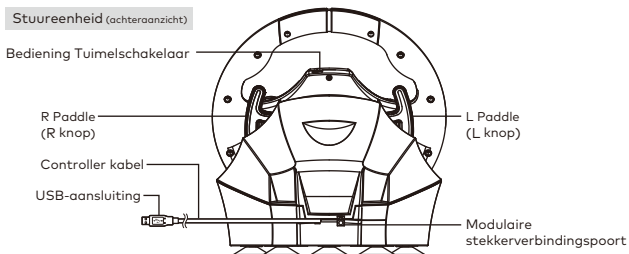

Voetpedalen

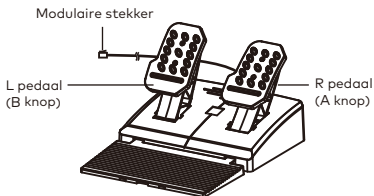



## Hoe te monteren

### Bestuurinrichting

#### Optie 1: Zuignap

- 1 Verwijder alle stof en vuil van uw tafelblad voordat u de controller vastzet met de vijf zuignappen.
- 2 Bevestig zuignappen aan stuurhuis tijdens het opstellen.



#### Optie 2: Klem

- 1 Draai de klemschroef in de stuurwielbasis.
- 2 Gebruik de klem om de stuurinrichting te bevestigen op een vlakke, harde ondergrond (bijv. tafel).



- Combineer beide bevestigingsmethoden niet, omdat dit de zuignappen kan beschadigen.
- Plak niet op meubels gemaakt van glas of andere breekbare materialen.
- Maak voorzichtig los van meubels om schade aan meubels of producten te voorkomen.

### Voetpedalen

Plaats voetpedalen op een vlakke ondergrond.



## Bedieningstuimelschakelaar

De bedieningselementen voor de richtingspad kunnen worden omgeschakeld naar de bedieningselementen voor de richtingspad, linker joystick of rechter joystick.

De directionele schakelknop van dit product werkt niet gegarandeerd met alle software.

- Raadpleeg de instructiehandleiding van de software. Dit product werkt niet met de analoge modus.



Directionele pad



Linker stok



Rechter stok

## Knop Hold-functie

Houd de Hold-knop ingedrukt om de ingedrukte status te behouden nadat u uw vinger hebt losgelaten.

### Hoe inschakelen

#### Houd 1 seconde ingedrukt

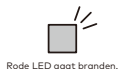

Rode LED gaat branden.

### Hoe uit te schakelen

#### Druk eenmaal



Rode LED gaat uit.

ZL knop / ITEM knop / L Paddle

Button Hold-functie werkt alleen wanneer de ITEM-knop de ITEM-functie heeft.

## LET OP Bij het spelen van Mario Kart

Terwijl de Button Hold-functie is ingeschakeld: als u het item wilt gebruiken dat u oppakt, druk eenmaal op een van de ZL-knop / ITEM-knop / L Paddle om de knopblokkering uit te schakelen. Druk vervolgens nogmaals op de knop om het item te gebruiken.

Met deze functie kunt u de functie van knoppen opnieuw toewijzen.

Programmeerbare knoppen	Toewijsbare functies
ZL / ZR / LSB / RSB / ITEM / L Paddle / R Paddle / L Pedaal / R Pedaal	A / B / X / Y / L / R / ZL / ZR / LSB / RSB / ITEM / L Paddle / R Paddle / Directionele pad (rechts/omlaag/links/omhoog) / Linker joystick (rechts/omlaag/links/omhoog) / Rechter stok (rechts/omlaag/links/omhoog)

Hoe aan te passen

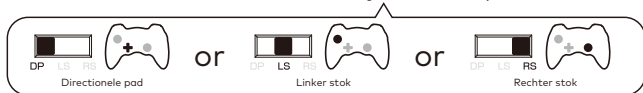
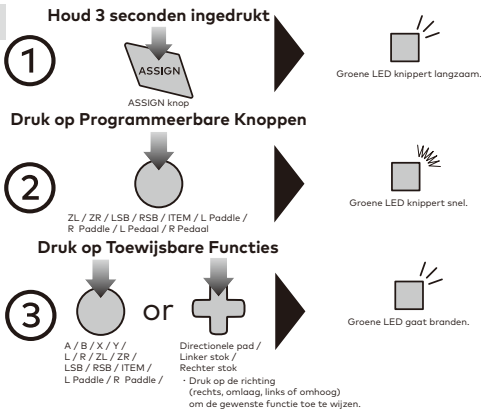

- Na 4 seconden inactiviteit tussen de stappen, gaat de programma-LED (rechts) uit en stopt de toewijzingsmodus.
- Tijdens stap 2 wordt de knopinvoer van de controller naar de Nintendo Switch™ uitgeschakeld.
- Wanneer de programmeer-LED (links) gaat branden, geeft dit aan dat een knop opnieuw is toegewezen en pas wordt uitgeschakeld nadat de knopfunctie is gereset naar de standaardinstelling.
- Als u de knopfunctie wilt uitschakelen, houdt u gedurende 3 seconden dezelfde knop ingedrukt die u in stap 2 ten tijde van stap 3 hebt ingedrukt.
- Als u tijdens stap 3 op meerdere knoppen hebt gedrukt, wordt de laatst ingedrukte knop toegewezen.
- Controllerinstellingen worden opgeslagen, zelfs als de USB wordt losgekoppeld.

### Hoe individuele knoppen te resetten

Gebruik stap 3 hierboven om de knoppen afzonderlijk terug te zetten naar de standaardwaarde.

### Hoe alle knoppen/functies op standaard te zetten

#### Houd 3 seconden ingedrukt

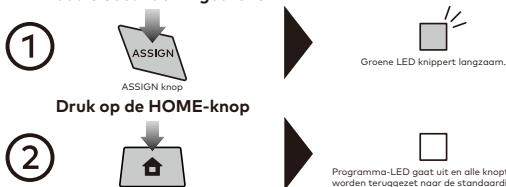

## ■ Snelle verwerkingsmodus

Ervaar een snellere bediening door de maximale stuuruitgang van 270 graden naar 180 graden te schakelen.

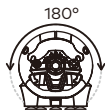

### Druk samen

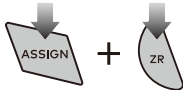

### Druk samen

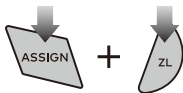

## ■ Instelbare gevoeligheid

De gevoeligheid van het stuur is instelbaar op zeven niveaus.  
De kleur van de programma-LED (links) verandert om de gevoeligheidswaarde aan te geven.

### Bestuurinrichting

#### Houd 3 seconden ingedrukt

1

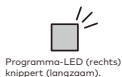

2

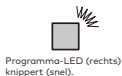

#### Zet de bedieningsschakelaar op LS

3



4



De gevoeligheidswaarde neemt toe door op de richtingsknop omhoog te drukken.

Minder responsief

5



De gevoeligheidswaarde neemt af door op de richtingsknop te drukken.

Geleidelijk

6



(De programma-LED (rechts) licht groen op bij het toewijzen van knoppen.)

- Als u stap 2 na 1 niet uitvoert, gaat de programma-LED (Rechts) na vier seconden uit en wordt de toewijzingsmodus automatisch beëindigd.
- Tijdens stap 2 ~ 6 zijn alleen de stuurunit en de voetpedaalingang ingeschakeld. Knopinvoer van de controller naar de Nintendo Switch™ wordt uitgeschakeld.
- Controllerinstellingen worden opgeslagen, zelfs als de USB wordt losgekoppeld.



	Geleidelijk (stabiel sturen)			Standaard	Responsive (eenvoudig te draaien)			
LED kleur	1 Groen	2 Geel	3 Rood	4 Purper	5 Blauw	6 Lichtblauw	7 Wit	

## ■ Instelbare Dode Zone



De Dode Zone is instelbaar in zeven niveaus.

De kleur van de programma-LED (links) verandert om de waarde voor de Dode Zone aan te geven.



### Houd 3 seconden ingedrukt

①   Programma-LED (rechts) knippert (langzaam).



Pless



②   Programma-LED (rechts) knippert (snel).

Zet de bedieningsschakelaar op DP



③  DP LS RS  De LED-kleur van het linkerprogramma verandert volgens de instelling en onderstaande tabel.

Pless

④   De gevoeligheidswaarde neemt toe door op de richtingsknop omhoog te drukken.

⑤   De gevoeligheidswaarde neemt af door op de richtingsknop te drukken.

Pless  
Pless

⑥   Programma-LED (links) gaat uit.  Programma-LED (rechts) gaat uit. (De programma-LED (rechts) licht groen op bij het toewijzen van knoppen.)







- Als u stap 2 na 1 niet uitvoert, gaat de programma-LED (Rechts) na vier seconden uit en wordt de toewijzingsmodus automatisch beëindigd.
- Tijdens stap 2 ~ 6 zijn alleen de stuurunit en de voetpedaalingang ingeschakeld. Knopinvoer van de controller naar de Nintendo Switch™ wordt uitgeschakeld.
- Controllerinstellingen worden opgeslagen, zelfs als de USB wordt losgekoppeld.

	smal			Standaard	Breed			
LED kleur	1 Groen	2 Geel	3 Rood	4 Purper	5 Blauw	6 Lichtblauw	7 Wit	

## ■ Reset terug naar standaardinstellingen

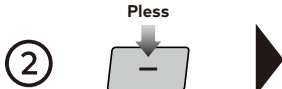
Om tegelijkertijd het volgende te resetten: Snelle bedieningsmodus • Dode Zone-aanpassing • Gevoeligheidsaanpassing.

### Houd 3 seconden ingedrukt

-  1  →  Programma-LED (rechts) knippert (langzaam).
-  2  →  Programma-LED (links) gaat uit.  Programma-LED (rechts) gaat uit.  
(De programma-LED (rechts) licht groen op bij het toewijzen van knoppen.)
-  3 Wanneer de Quick Handling Mode wordt geannuleerd, wordt de invoerwaarde van het stuur standaard ingesteld op 270 °. Standaardwaarden voor Dode Zone en gevoeligheid zijn ingesteld op "4".
  - Als u stap 2 na 1 niet uitvoert, gaat de programma-LED (Rechts) na vier seconden uit en wordt de toewijzingsmodus automatisch beëindigd.

## ■ Let op

- Demonteer, repareer of wijzig dit product nooit.
- Houd de controller uit de buurt van stoffige of vochtige gebieden.
- Pas geen sterke impact of gewicht op het product toe.
- Trek niet ruw en buig de kabel van de controller niet.
- Als het product moet worden schoongemaakt, gebruik dan alleen een zachte, droge doek. Gebruik geen chemische middelen zoals benzine of verdunner.
- Houd dit product buiten het bereik van kinderen jonger dan 3 jaar.

## ■ Hoofdspecificaties

### Bestuurinrichting

Externe afmetingen : 280 × 275 × 286mm

Diameter stuurwiel : 280mm

Gewicht : 1400g

Rotatiehoek : 270°

Kabellengte : 3m

### Voetpedalen

External Dimensions : 234 × 305 × 180mm

Gewicht : 700g

Kabellengte : 1.5m

## DE FCC WILT U WETEN

Dit apparaat voldoet aan deel 15 van de FCC-regels. Gebruik is onderworpen aan de volgende twee voorwaarden:

(1) Dit apparaat mag geen schadelijke interferentie veroorzaken, en (2) dit apparaat moet ontvangen interferentie accepteren, inclusief interferentie die een ongewenste werking kan veroorzaken.

## DE FCC WILT U WETEN

Deze apparatuur is getest en voldoet aan de limieten voor een Klasse B digitaal apparaat, conform Deel 15 van de FCC-regels.

Deze limieten zijn bedoeld om een redelijke bescherming te bieden tegen schadelijke interferentie in een residentiële installatie.

Deze apparatuur genereert, gebruikt en kan radiofrequentie-energie uitstralen en kan, indien niet geïnstalleerd en gebruikt in

overeenstemming met de instructies, schadelijke interferentie met radiocommunicatie veroorzaken.

Er is echter geen garantie dat er geen interferentie zal optreden in een bepaalde installatie.

Als deze apparatuur schadelijke interferentie veroorzaakt voor radio- of televisieontvangst, wat kan worden vastgesteld door de apparatuur uit en in te schakelen, wordt de gebruiker aangemoedigd om te proberen de interferentie te verhelpen door een of meer van de volgende maatregelen:

- Heroriënteer of verplaats de ontvangende antenne.
- Vergroot de afstand tussen het apparaat en de ontvanger.

## PRODUCT AFHANDELINGSINFORMATIE

Wanneer u dit symbool op een van onze elektrische producten of verpakkingen ziet, betekent dit dat het relevante

elektrische product of de batterij niet als algemeen huishoudelijk afval in Europa mag worden weggegooid.

Verwijder de juiste afvalverwerking van het product en de batterij volgens de geldende lokale wetgeving of

voorschriften voor het weggoien van elektrische apparatuur of batterijen. Door dit te doen, helpt u bij het

behoud van natuurlijke hulpbronnen en het verbeteren van de normen voor milieubescherming bij de behandeling

en verwijdering van elektrisch afval. Alleen van toepassing op EU-landen.



Alleen EU en Turkije

## US

### Garantie

HORI garandeert de oorspronkelijke koper dat het nieuw gekochte product in de originele verpakking vrij is van materiaal- en fabricagefouten gedurende een periode van 90 dagen vanaf de oorspronkelijke aankoopdatum. Als de garantieclaim niet kan worden verwerkt via de oorspronkelijke verkoper, kunt u rechtstreeks contact opnemen met HORI op [infous@hori.jp](mailto:infous@hori.jp).

Please visit <http://stores.horiusa.com/policies/> for Garantie details.

## EU

### Garantie

Neem voor alle garantieclaims binnen de eerste 30 dagen na aankoop contact op met de winkel waar de oorspronkelijke aankoop is gedaan voor meer informatie. Als de garantieclaim niet kan worden verwerkt via de oorspronkelijke verkoper of voor andere vragen met betrekking tot onze producten, neem dan rechtstreeks contact op met HORI op [infoeu@hori.jp](mailto:infoeu@hori.jp).

De afbeelding op de verpakking kan afwijken van het werkelijke product.

De fabrikant behoudt zich het recht voor om het productontwerp of de specificaties zonder voorafgaande kennisgeving te wijzigen.

De draden mogen niet in stopcontacten worden gestoken.

De verpakking moet worden bewaard omdat deze belangrijke informatie bevat.

HORI & HORI-logo zijn geregistreerde handelsmerken van HORI.



GEMAAKT IN CHINA