

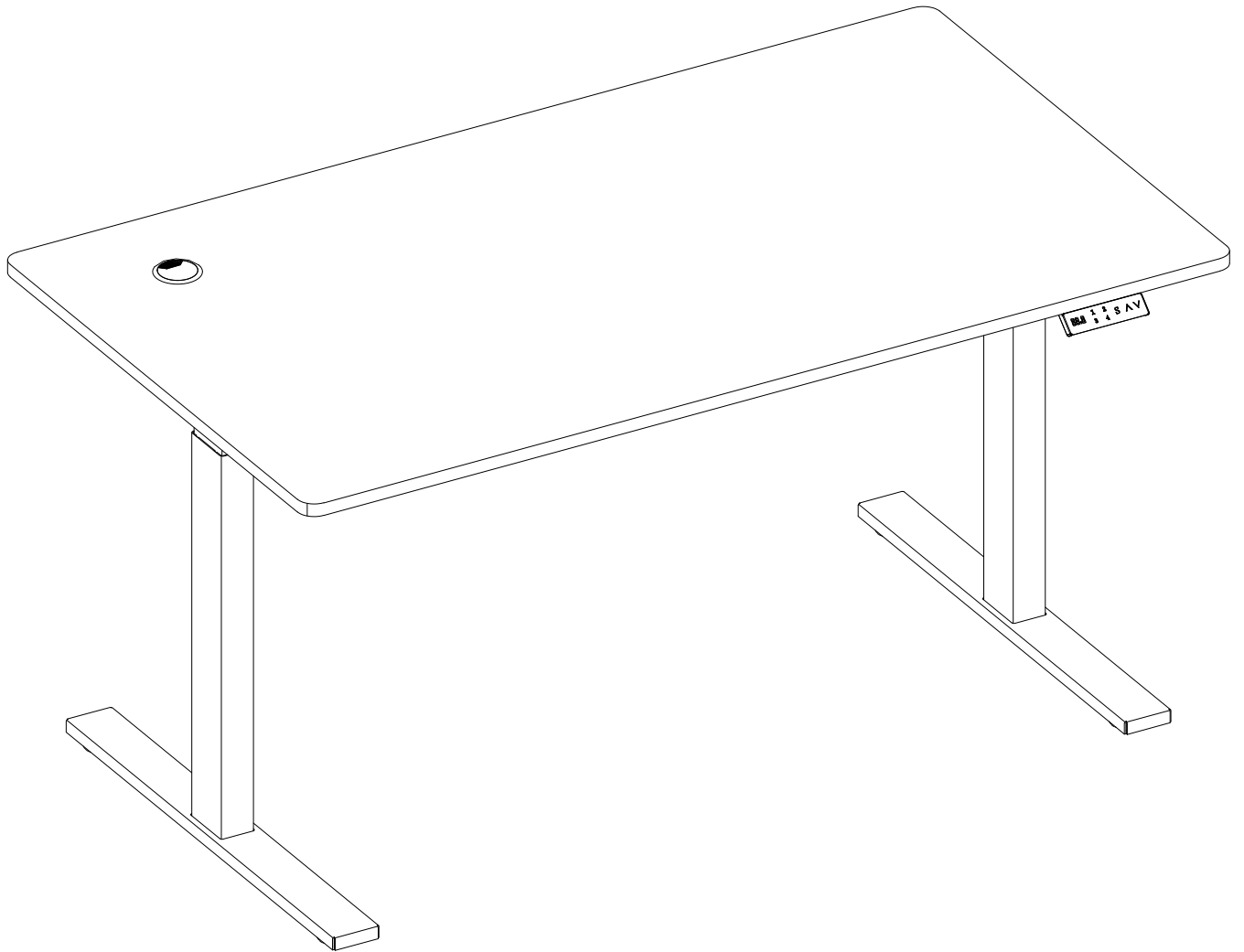

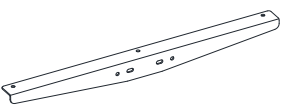



Montagehandleiding Installation instruction Installationsanleitung

Model: E-base 125

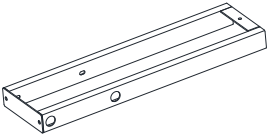
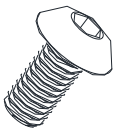
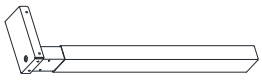
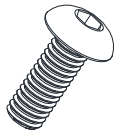
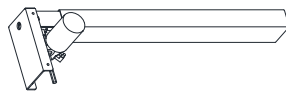
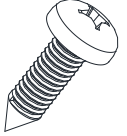

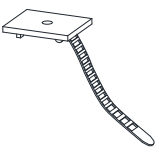
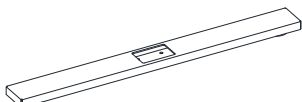
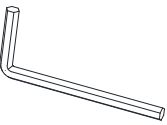
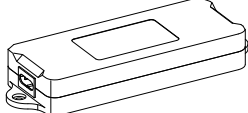
A	Side Bracket Zijbeugel Seitenhalterung		2pcs	L	Cabinet Wheel Stelschroef tafelvoet Einstellschraube Tischfuß		4pc
B	Frame		2pcs	M	M6X12 Hex Screw		32pcs
C	Column Tafelpoot Tischbein (no motor)		1pc	N	M6*16 Hex Screw		8pcs
D	Column Tafelpoot Tischbein (with motor)		1pc	O	Self-Tapping Screws ST4X16		5pcs
E	Connection Bar Verbindingsstang Pleuelstange		2pcs	P	Ribbon/wrap tie Kabelbinder		5pcs
F	Table Foot Tafelvoet Tischfuß		2pcs	Q	4mm Hex Wrench Inbus		1pc
G	Control Box		1pc	R	M4*12 Cross Screw		4pcs
H	Power Cord Stroomkabel Netzkabel		1pc	S	Wire through Kabelgoot Kabekrinne Plastic		1pcs
I	Tabletop Bureaublad Tischplatte (optional)		1pc	T	Standby / extra Screw Bag		1pc
J	Transmission bar Transmissiestang Übertragungsstange		1pc				
K	Hand controller		1pcs				

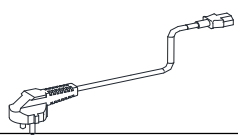
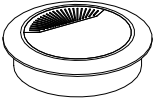
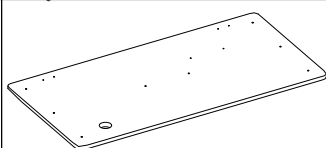
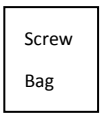
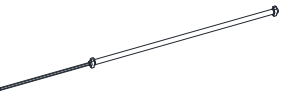
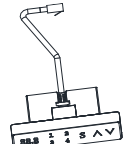
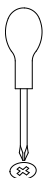

*Crosshead screwdriver required for installation.
Kruiskop schroevendraaier nodig voor installatie.
Für die Installation ist ein Kreuzschlitz schraubendreher erforderlich.*

2

N X8

Q X1

L X4

F X2

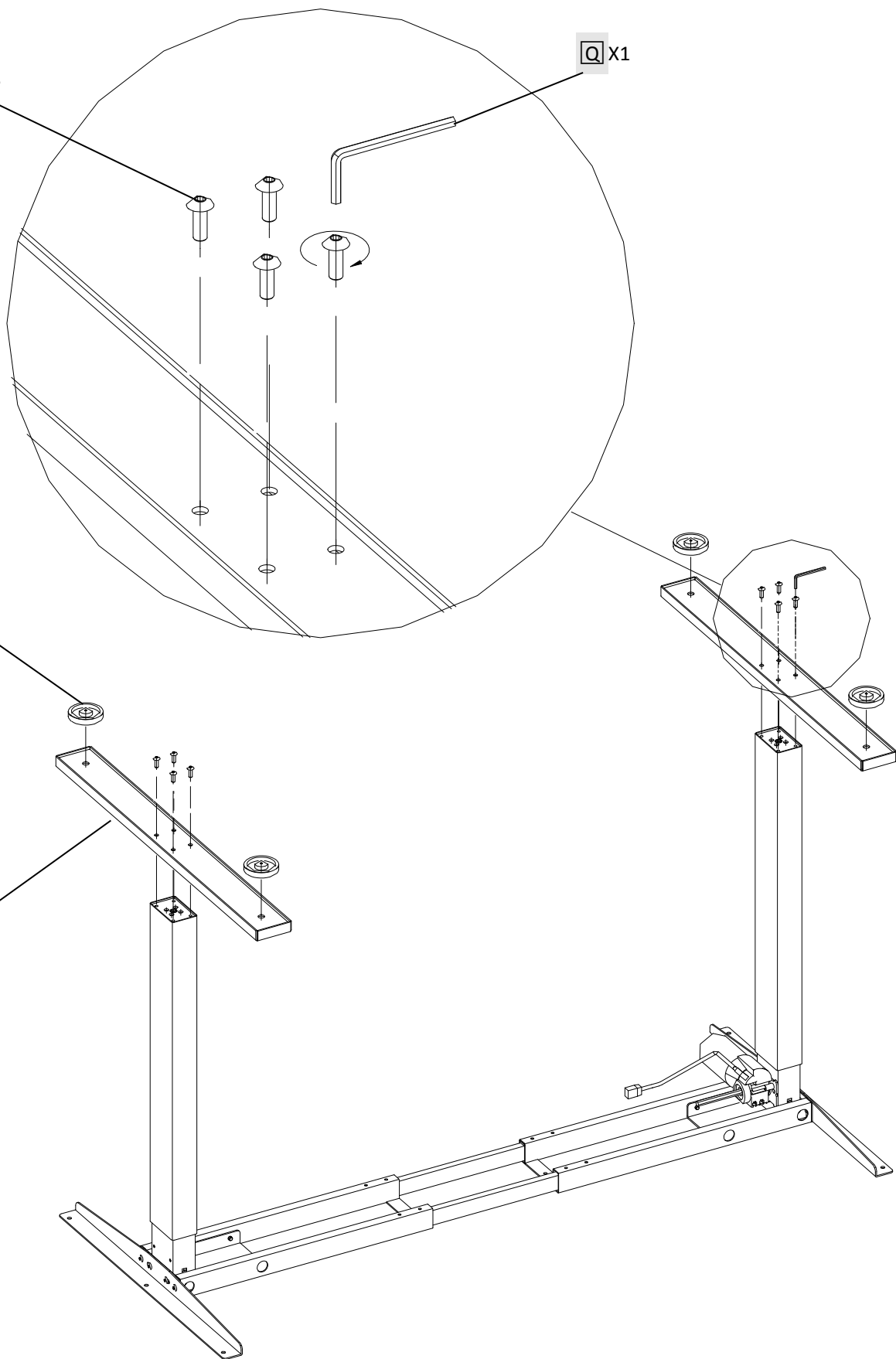

③

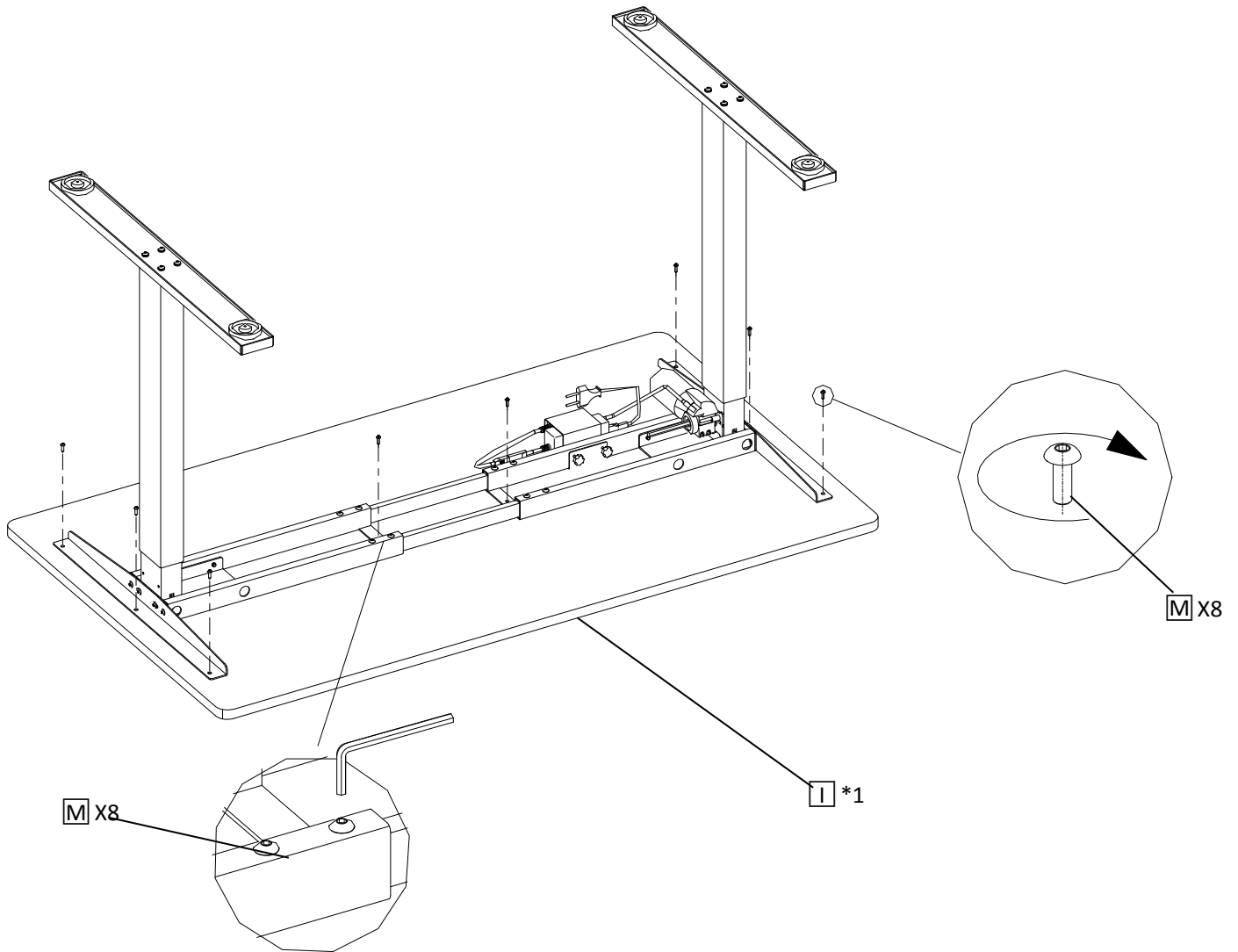

EN: After adjusted the frame width,tighten the M6X12 screw (M) with a hexagon wrench (Q) to fix the connecting rod (E).

DE: Ziehen Sie nach dem Einstellen der Rahmenbreite die Schraube M6x12 (M) mit einem Inbusschlüssel (Q) fest, um die Pleuelstange (E) zu sichern.

NL: Nadat de framebreedte is aangepast, draait u de M6x12-schroef (M) vast met een inbussleutel (Q) om de verbindingsstang (E) vast te zetten.

4

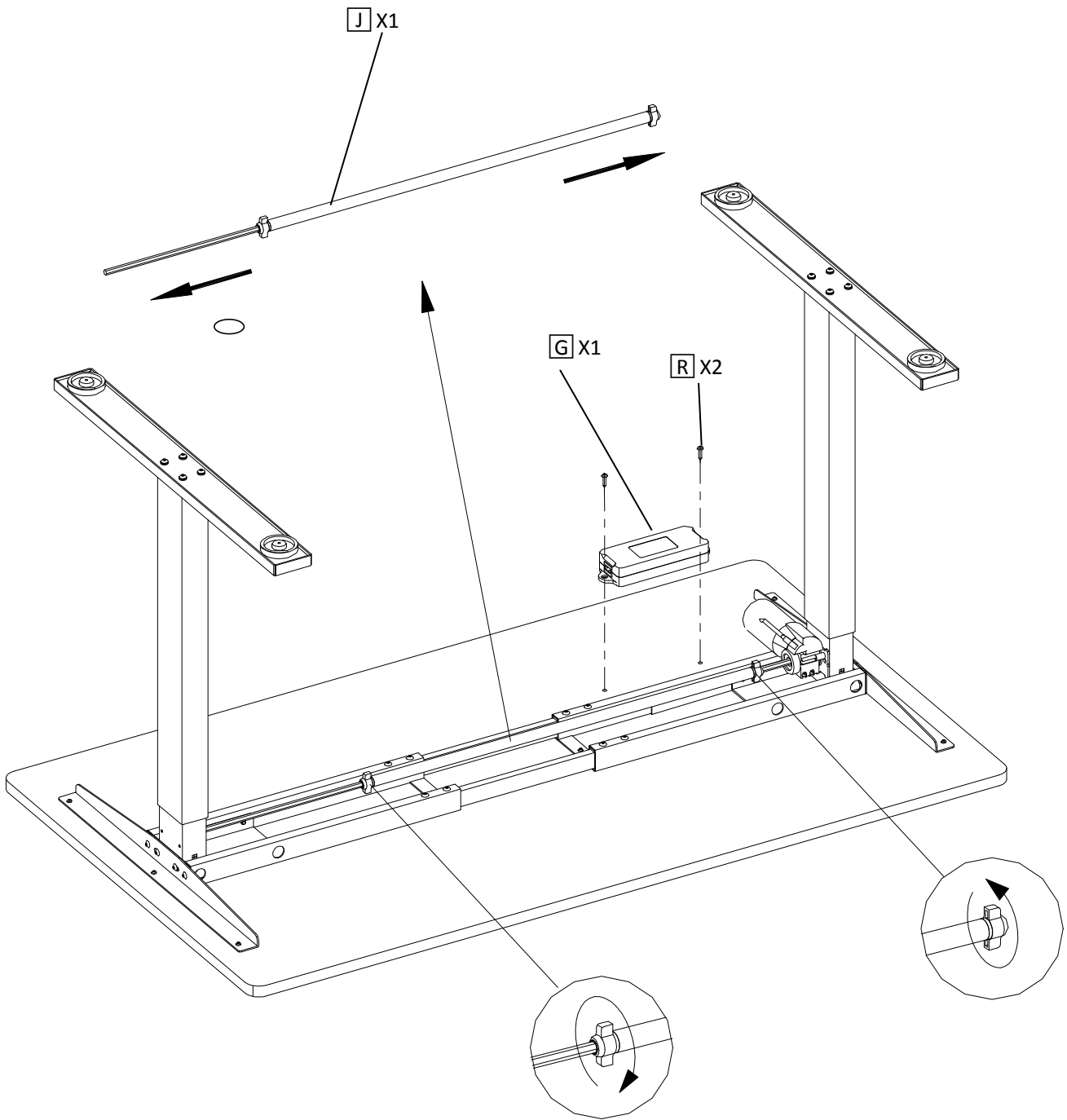

EN: While mounting the transmission bar (E), insert the transmission bar to the end of the column (without motor), then transmit the transmission bar with hand to align the other column (with motor). Tighten the plastic cap after installation.

DE: Platzieren Sie beim Zusammenbau der Übertragungsstange (J) die Übertragungsstange am Ende des Tischbeins (ohne Motor) und stellen Sie die Übertragungsstange von Hand ein, um das andere Tischbein (mit Motor) auszurichten.

NL: Tijdens het monteren van de transmissie stang (J), plaats de transmissiestang aan het einde van de tafelpoot (zonder motor), en stel vervolgens de transmissiestang met de hand om de andere tafelpoot (met motor) uit te lijnen. Draai de plastic dop aan beide kanten vast na installatie.

5



EN: The socket of the Control box need to point towards the column with motor so the motor wire can be connected with the control box in the shortest distance .

DE: Der Verbindungspunkt des Control box muss mit dem Motor zum Tischbein zeigen, damit der Stecker in kürzester Entfernung an den Control box angeschlossen werden kann.

NL: Het aansluitpunt van de control box moet gericht zijn naar de tafelpoot met motor zodat de stekker via de kortste afstand met de control box kan worden verbonden.

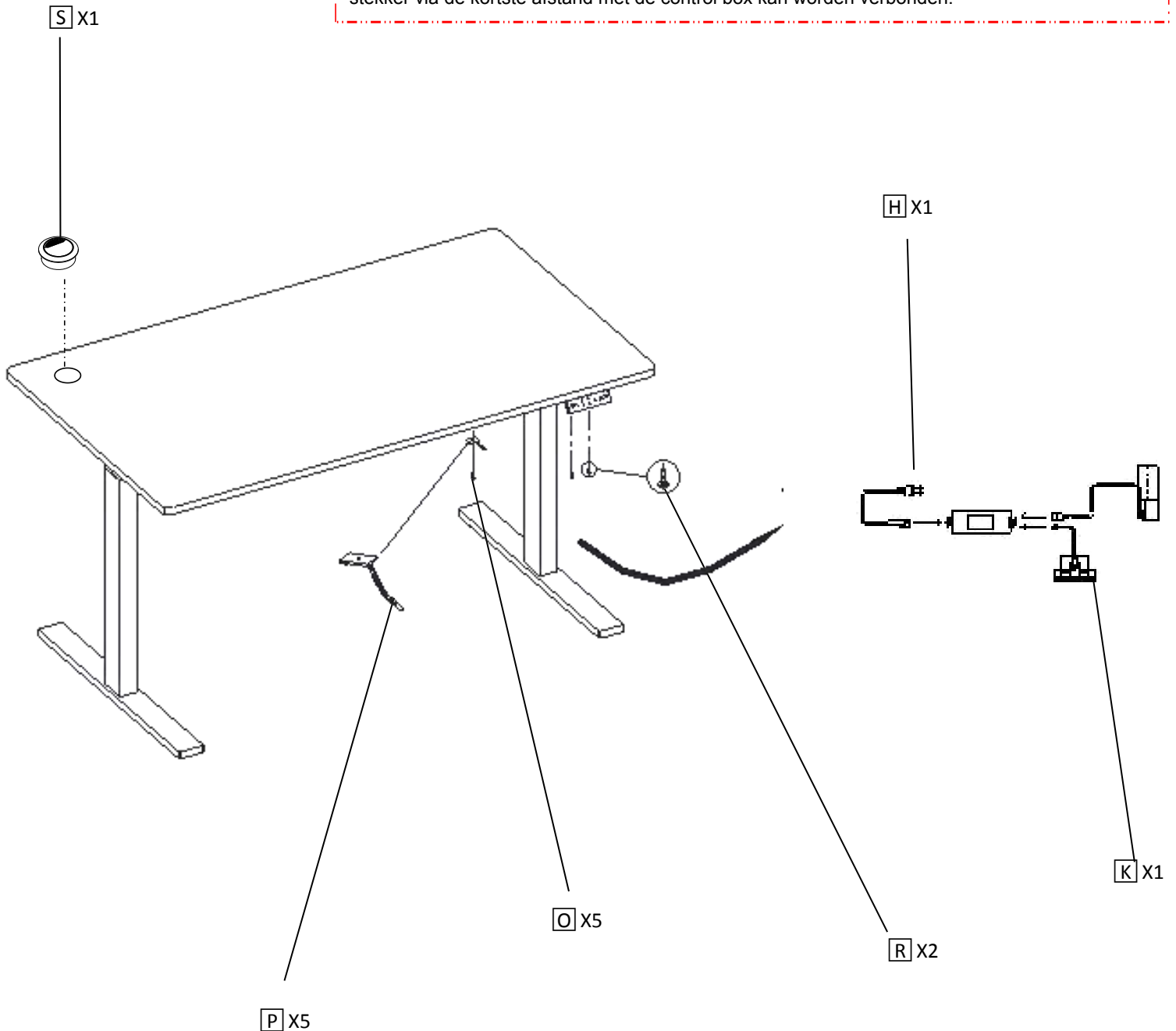

EN: When fixing the wires with tie, be careful to avoid the transmission bar

DE: Vermeiden Sie die Übertragungsstange, wenn Sie die Drähte mit dem Kabelbinder sichern.

NL: Pas op dat u de transmissiestang vermijdt wanneer u de draden met de kabelbinder vastzet.

User Manual:

1.Touch button instruction

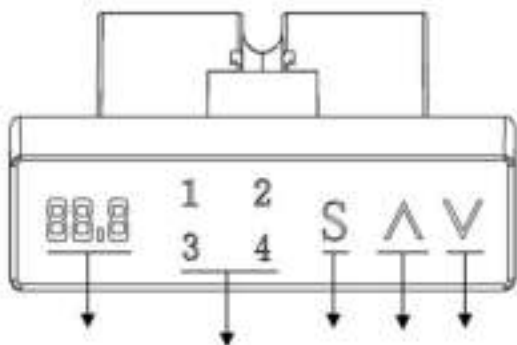

Led display Memory Save UP Down

2.Reset

EN: Hold touch down button“∨”, System enter initialization mode, until led display show lowest height.

DE: Halten Sie die Taste “∨” gedrückt, und das System wechselt in den Initialisierungsmodus, bis die LED-Anzeige die Höhe anzeigt.

NL: Houd de toets “∨” ingedrukt, het systeem gaat naar de initialisatiemodus, totdat het led-display de hoogte aangeeft.

3.Position reserve and memory run / Speicherposition einstellen / Geheugenpositie instellen

EN: Touch “S” button , indicator show “S-” , meanwhile “- -” flicker , at the same time touch“1-4”button , reserve this position to relative “1-4”,four memory positions can reserve

DE: Berühren Sie die Taste "S", die Anzeige zeigt "S -" an, während "- -" blinkt, berühren Sie gleichzeitig die Taste 1, 2, 3 oder 4", um diese Höhe zu speichern.

NL: Raak de "S" -knop aan, de indicator toont "S -", ondertussen "- -" flinkt, raak tegelijkertijd de knop 1,2,3 of 4" aan waarop je deze hoogte wilt bewaren.

4. Lock and unlock / Vergrendelen en ontgrendelen / Sperren und Entsperren

EN: Lock : hold touch“S”+“^” for 5s , indicator show“LOC”, this means system has been locked, can not do any operation.

Unlock : hold touch“S”+“∨” for 5s , when indicator shows “LOC”change to normal figure, this means system is unlocked.

DE: Sperren: Halten Sie "S" + " ^ " 5 Sekunden lang gedrückt. Die Anzeige zeigt "LOC" an. Dies bedeutet, dass das System gesperrt ist und keine Operation ausführen kann.

Entsperren: Halten Sie die Taste "S" + "Berühren" 5 Sekunden lang gedrückt. Wenn die Anzeige "LOC" anzeigt, ändern Sie die Höhe. Dies bedeutet, dass das System entsperrt ist.

NL: Vergrendelen: houd "S" + " ^ " 5 seconden ingedrukt, de indicator toont "LOC", dit betekent dat het systeem is vergrendeld en geen enkele handeling kan uitvoeren.

Ontgrendelen: houd de toets "S" + "touch" 5 seconden ingedrukt, wanneer de indicator "LOC" aangeeft, wijzig de hoogte, dit betekent dat het systeem is ontgrendeld.

5. Remark / Anmerkung / Opmerking

EN: If indicator show "hot overheat or continuously work over 2 mins. It'll be unlocked automatically after 18 mins rest.

DE: Wenn die Anzeige "hot" anzeigt, bedeutet dies, dass das System überhitzt ist oder 2 Minuten lang ununterbrochen gearbeitet hat. Nach 2 Minuten vollem Betrieb muss das System mindestens 18 Minuten abkühlen.

NL: Als de indicator "hot" aangeeft, betekent dit dat het systeem oververhit is of continu gewerkt heeft gedurende 2 minuten. Na 2 minuten voluit gewerkt te hebben moet het systeem minimaal 18 min afkoelen.

6. Error codes

Error code	Instruction / Anweisung / Instructie	Process method / Lösung / Oplossing
E05	Anti collision / Antikollisions / Anti botsing	Indicator light off / Kontrollleuchte aus / Indicatorlampje uit
E08	Desk tilt or control box shake Kippen Sie den Schreibtisch oder schütteln Sie die Steuerbox Bureau kantelen of schudden van de schakelkast	Fix control box Bringen Sie den Schaltkasten an Bevestig de schakelkast

7. Specifications

Input	100V/230V AC	Frame size	W(1100~1600)*D575mm
Load Capacity:	80kg	Frame height	750-1250mm
Noice:	<52dB	Operation	0~40°C
Max.Speed:	25mm/s	Duty Cycle:	Max. 2 min. on / 18 min off