

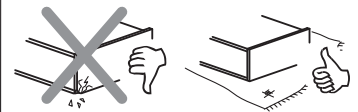

<b>A</b>		M6x30mm VB1080	<b>D</b>		M6x25mm VB1139	<b>G</b>		99-KD0-0025-01SW
<b>B</b>		76 mm BGBE0571	<b>E</b>		UX8R VB1243	<b>H</b>		VB1178
<b>C</b>		Ø18mm ZU1046	<b>F</b>		6x80mm 91-B50-6.0080-4ZB			

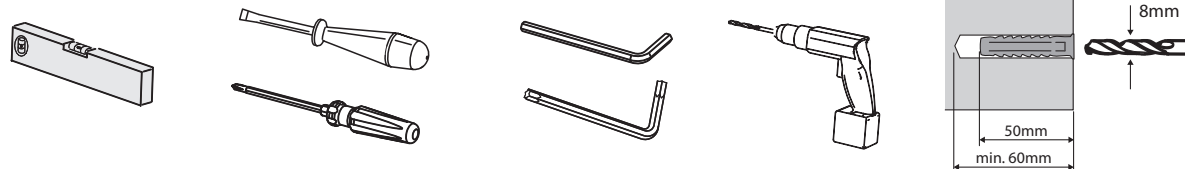

Elemente mit Schublade/  
Elements with drawer:

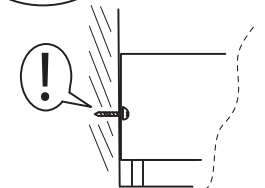

TV-Gerät möglichst weit  
hinten platzieren /  
Place TV as far back as  
possible

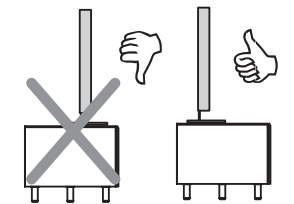

**Gesamtblastung / Total load:**  
Max. 60 kg pro Element /  
Max. 60 kg per element

**Deckplatte / Top plate:**  
Max. 45 kg

**Glaseinlegeböden / Glass shelves:**  
Max. 15 kg

**Schubladen / Drawers:**  
Max. 20 kg pro Schubladenfach /  
Max. 20 kg per drawer compartment



**(D)**

Mäßiges Anziehen von Hand genügt, keine Gewalt anwenden!  
Nicht mit scheuernden Mitteln reinigen!  
Wir übernehmen keine Gewähr/Haftung für den Aufbau bzw. die Montage.  
Konstruktionsänderungen vorbehalten.  
Bitte beachten Sie beim Betrieb von Geräten in Elementen mit geschlossener, luftundurchlässiger Front die Herstellerhinweise Ihrer Audio- und Videokomponenten bezüglich Belüftung.  
Eventuell muss bei Geräten mit starker Hitzeentwicklung die Front während des Betriebs geöffnet sein, um einen Hitzestau zu vermeiden.

**(F)**

Vissage uniquement manuel. Un serrage excessif peut endommager la surface et les éléments.  
Ne pas utiliser de matière abrasive ou chimique qui pourrait détériorer la surface.  
Nous ne pouvons être tenu responsable pour des défauts ou des dégâts causés par un assemblage ou un montage non conforme.  
Nous nous réservons le droit d'apporter des modifications techniques.  
Lors de l'utilisation d'appareils dans des éléments dont la façade est fermée et ne laisse pas passer l'air, observer les instructions du fabricant des composants audio et vidéo en matière de ventilation.  
Il peut être éventuellement nécessaire d'ouvrir la façade pendant le fonctionnement des appareils qui dégagent beaucoup de chaleur afin d'éviter toute surchauffe.

**(GB)**

Tighten only by hand. Over tightening may cause damage to both glass and fittings.  
Please do not use abrasive materials or chemicals, which may cause damage to the surface.  
Please note that we cannot accept responsibility for faults or damage caused by wrong assembly and/or mounting.  
Subject to design change.  
Please note the manufacturer's instructions on ventilation for your audio and video equipment when operating devices in elements with a closed, airtight front.  
It may be necessary to leave the front open during operation to prevent internal heat accumulation for devices that generate excessive heat.

**(I)**

Serrare solo a mano. Un serraggio eccessivo può causare rottura dei cristalli e di altre componenti.  
Attenzione non usare materiali abrasivi o chimici poiché potrebbero danneggiare la superficie.  
Attenzione! Nessuna responsabilità potrà esserci attribuita per problemi causati da una scorretta installazione o assemblaggio.  
Con riserva di modifiche.  
Durante il funzionamento dei dispositivi in elementi con parete anteriore chiusa e che impedisce il passaggio d'aria bisogna rispettare le indicazioni del produttore dei componenti audio e video in relazione alla ventilazione.  
Eventualmente, con i dispositivi con forte sviluppo di calore bisogna aprire la parete anteriore per evitare un accumulo di calore.

**(E)**

Ajustar solo con las manos. Un ajuste excesivo puede causar daños tanto al cristal como a las fijaciones.  
Por favor no usar materiales abrasivos químicos, que puedan causar daños a la superficie.  
Por favor, se consciente que nosotros no podemos aceptar responsabilidad por faltas causadas por un mal montaje o ensamblado.  
Salvo modificación.  
Tenga en cuenta las recomendaciones del fabricante en cuanto a la ventilación para aparatos de audio y componentes de video con un panel frontal cerrado o hermético.  
Puede que en algunos aparatos con calor excesivo sea necesario abrir el panel frontal durante el funcionamiento para evitar un sobrecalentamiento.

**(NL)**

Alleen handmatig strak aandraaien. Te strak aandraaien kan schade aanbrengen aan zowel het glas als de hechtingsplaats.  
Gebruik s.v.p. geen materiaal dat kan schuren of chemische producten aangezien dit schade kan aanbrengen.  
De fabrikant kan geen verantwoordelijkheid nemen voor schade ontstaan door verkeerde montage of ophanging.  
Onderhevig aan verandering.  
Bij het gebruik van apparaten in elementen met gesloten, luchtdichte front volgt u de instructies van de fabrikant van uw audio- en videocomponenten op wat betreft de ventilatie.  
Eventueel moet bij apparaten met een sterke warmteontwikkeling het front tijdens het gebruik geopend zijn om een warmteophoping te vermijden.

**(P)**

Aperte manualmente os parafusos. Um aperto excessivo poderá danificar tanto o vidro como as junções.  
Não utilizar produtos abrasivos ou químicos, pois estes poderão danificar as superfícies.  
Não poderemos aceitar quaisquer responsabilidades de acidentes inerentes a erros de montagem ou instalação deficiente.  
Sujeito a alterações.  
Durante a operação de aparelho em elementos com a frente fechada, impermeável ao ar, tenha em atenção as indicações do fabricante dos seus componentes áudio e vídeo relativamente à ventilação.  
Eventualmente em aparelhos com um intenso desenvolvimento de calor, a frente deverá estar aberta durante o funcionamento para evitar uma acumulação de calor.

**(TR)**

Sadece elle sıkıştırınız. Aşırı sıkıştırma hem cama hem de düzeneğe zara verebilir.  
Lütfen yüzeye zarar verebilecek olan aşındırıcı maddeler veya kimyasal maddeleri kullanmayınız.  
Lütfen yanlış bir araya getirme ve/veya montaj yüzünden meydana gelen hatalar veya hasarlar için sorumluluk kabul etmeyeceğimize dikkat ediniz.  
Cihazları kapalı, hava geçirmez ön cepheye sahip elemanlarda çalıştırırken, ses ve video bileşenleri üreticilerinizin havalandırma ile ilgili uyarılarını lütfen dikkate alın.  
Gerektiğinde, yoğun ısı oluşumlu cihazlarda ısı birikiminin önlenmesi için ön çalıştırma esnasında cephe açık tutulmalıdır.

**(RUS)**

Затягивайте вручную. Излишние усилия при затяжке могут привести к повреждению стекла и фурнитуры.  
Не используйте абразивные материалы или химикаты, это может привести к повреждению поверхности.  
Обращаем Ваше внимание что мы не несем ответственности за разрушения и повреждения, вызванные неправильной сборкой и монтажом.  
Возможны изменения.  
При эксплуатации устройств с закрытой панелью необходимо соблюдать указания производителя аудио- и видеоборудования относительно вентиляции.  
Чтобы предотвратить накопление тепла, для устройств с большим тепловыделением может потребоваться оставить открытой переднюю панель во время работы.

1 Elemente mit Schublade /  
Elements with drawer



2

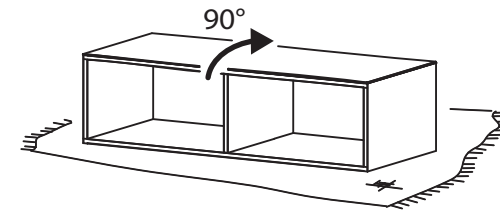

3

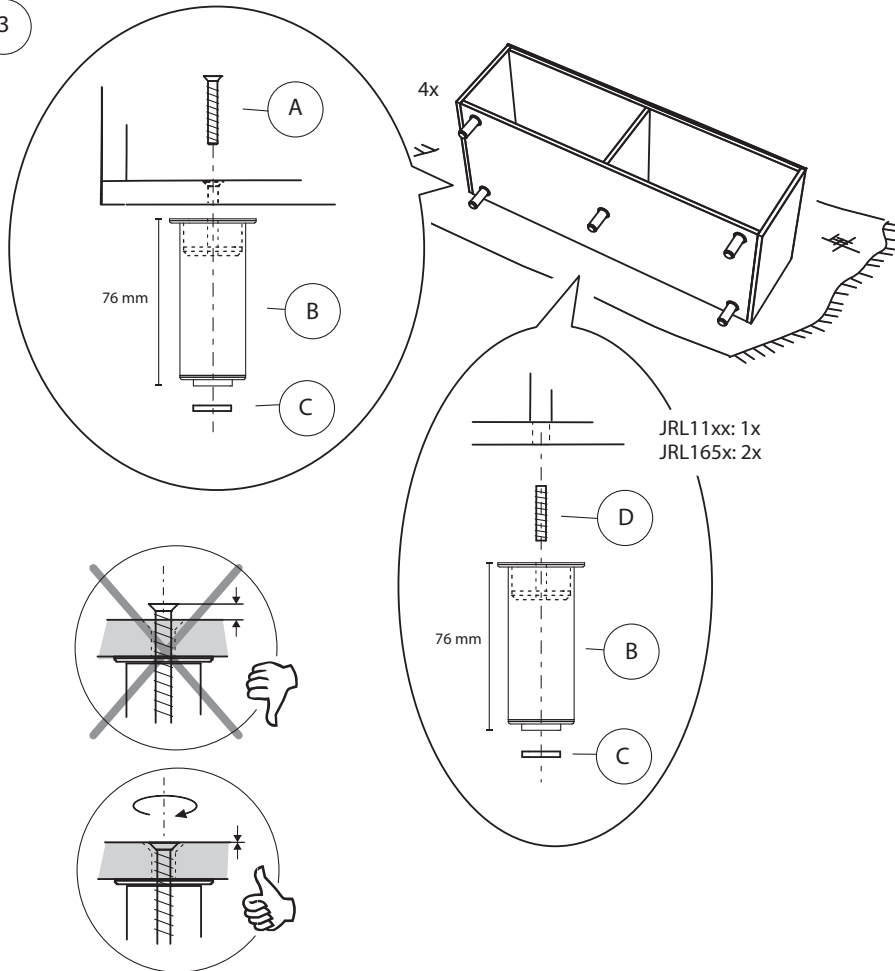

4

Elemente mit TV-Halterung /  
Elements with TV mount

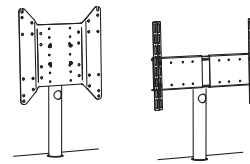

Siehe Anleitung TV-Halterung /  
See manual of the TV mount



5

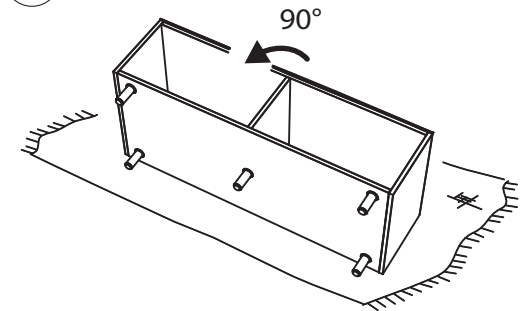

6

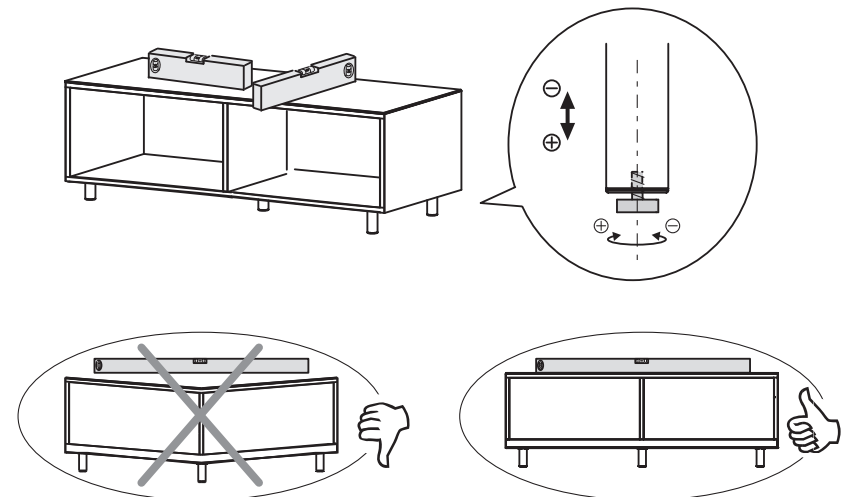

7 Elemente mit Schublade/  
Elements with drawer

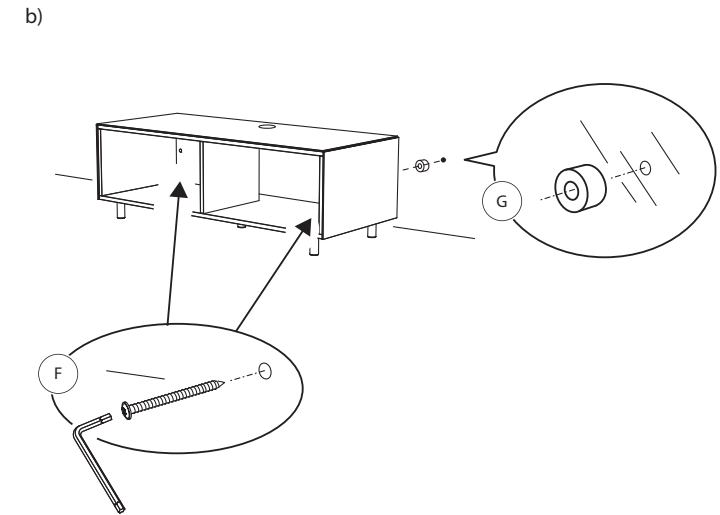
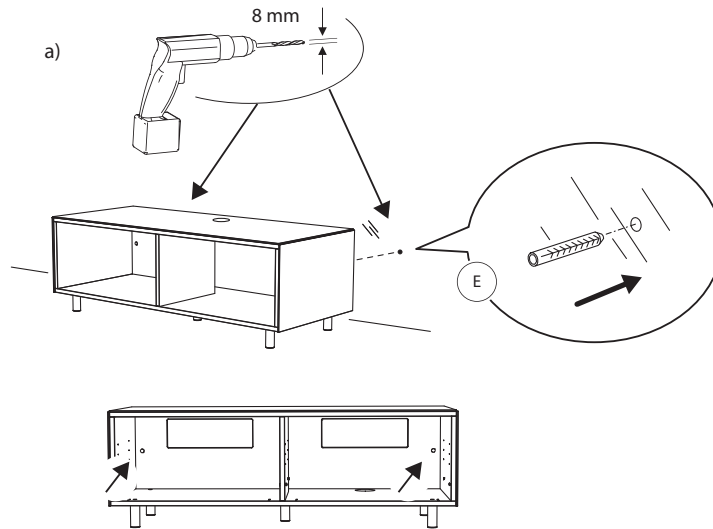
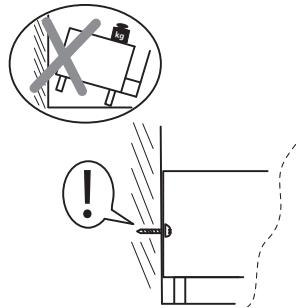

8 Elemente mit Glaseinlegeböden /  
Elements with glass shelves

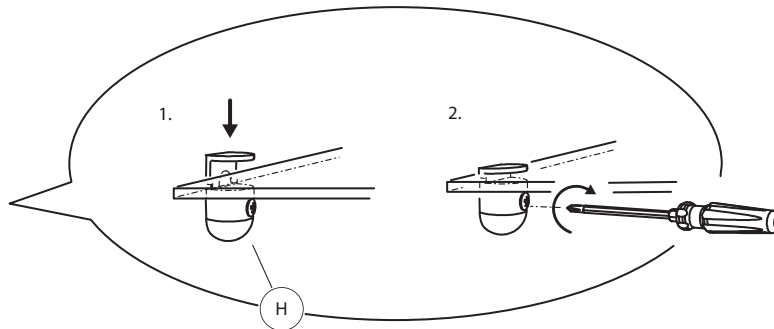
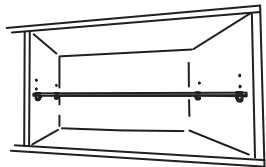

10 Elemente mit Schublade/  
Elements with drawer

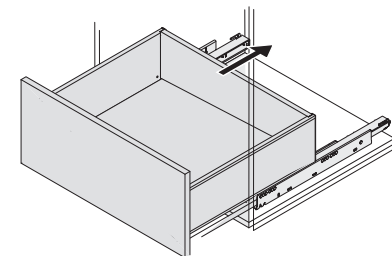
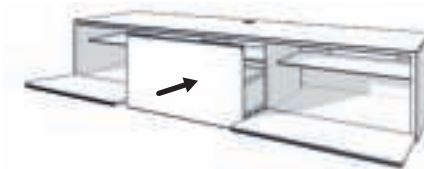

9 Elemente mit Universal Soundbar Ablageblech /  
Elements with universal soundbar tray

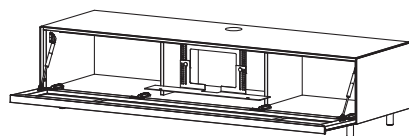

Siehe Anleitung  
Universal Soundbar Ablageblech /  
See manual of the  
universal soundbar tray

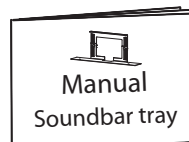

11 Elemente mit Schublade/  
Elements with drawer

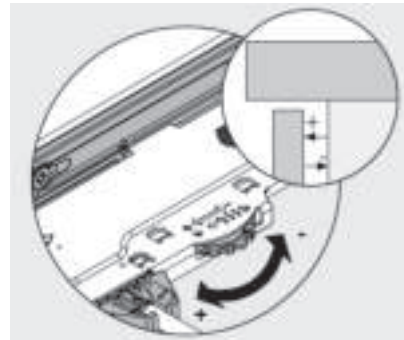
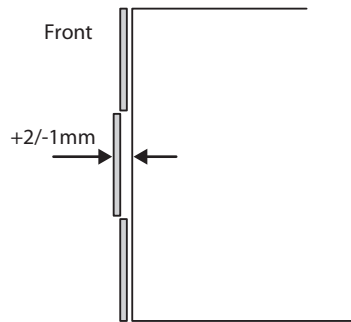
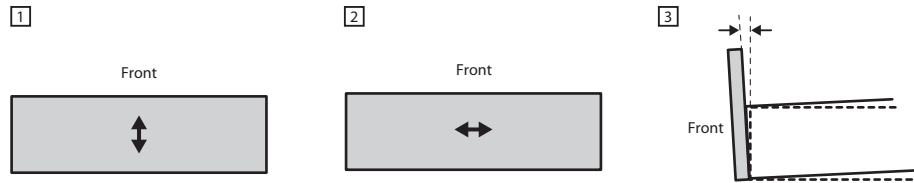
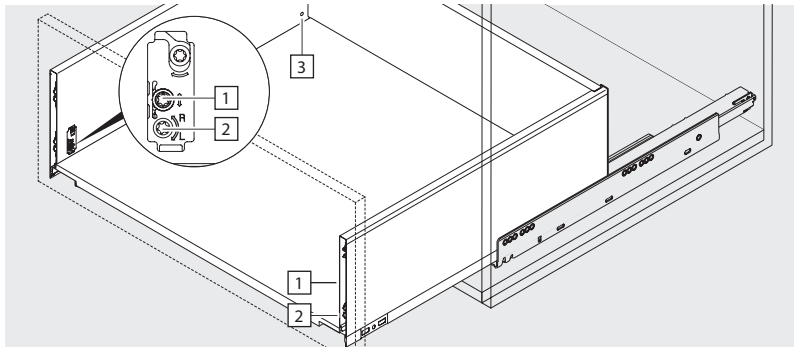
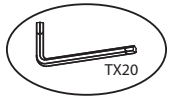

12 Elemente mit Klappe /  
Elements with flap

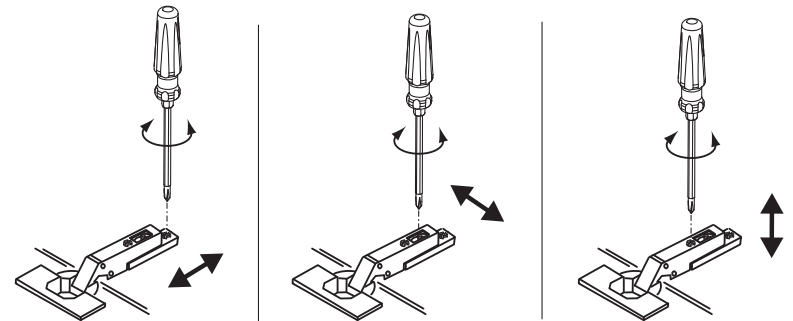
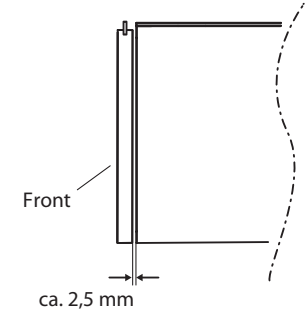
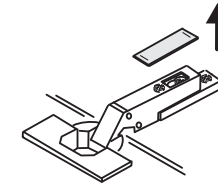

13 Elemente mit Schutzfolie /  
Elements with protective film

