

ASSEMBLY STEPS

*Wash all pieces of the FLASK prior to use

- 1 Insert metal screen filter** onto the base with silicon tabs facing up.
- 2 Optional:** Insert paper filter on top of metal screen filter.
- 3 Connect the base** to the bottom of the brewing chamber.
- 4 Twist the base** to lock in place.
- 5 Insert the brewing chamber** into the FLASK body.

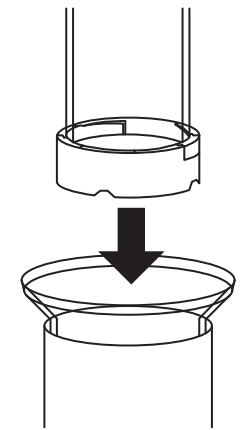
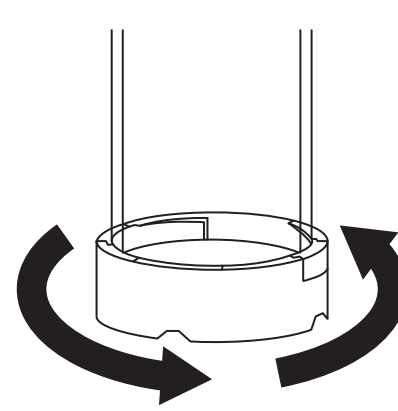
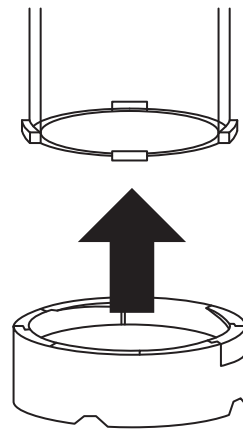
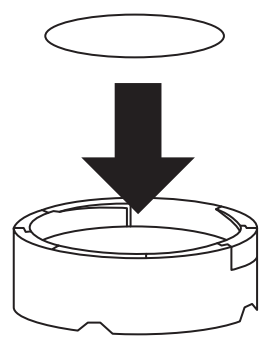
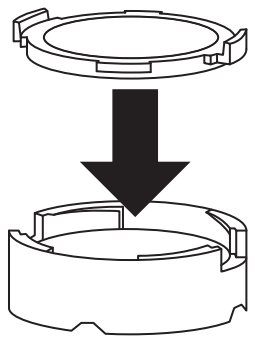

BREWING STEPS

- 1 Add coffee** (medium-fine grounds). Amount depends on how strong you like your brew. The included scoop holds approximately 2 tbsp, so using 2 scoops provides ~4 tbsp of coffee. Add more if you would like to allow for dilution later.
- 2 Add enough hot water to just cover grounds.** Wait 30 seconds to allow grounds to bloom and float to the top.
- 3 Add remaining hot water** to the brewing chamber. Fill to dotted line, or to the bottom of the FLASK outer band. This is approximately 17 fl oz of water.

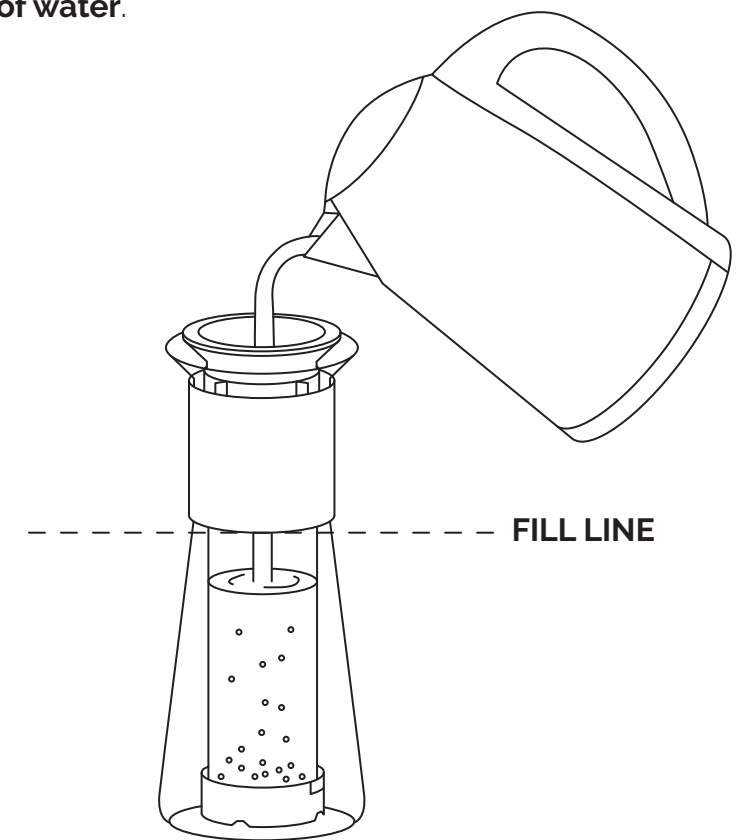
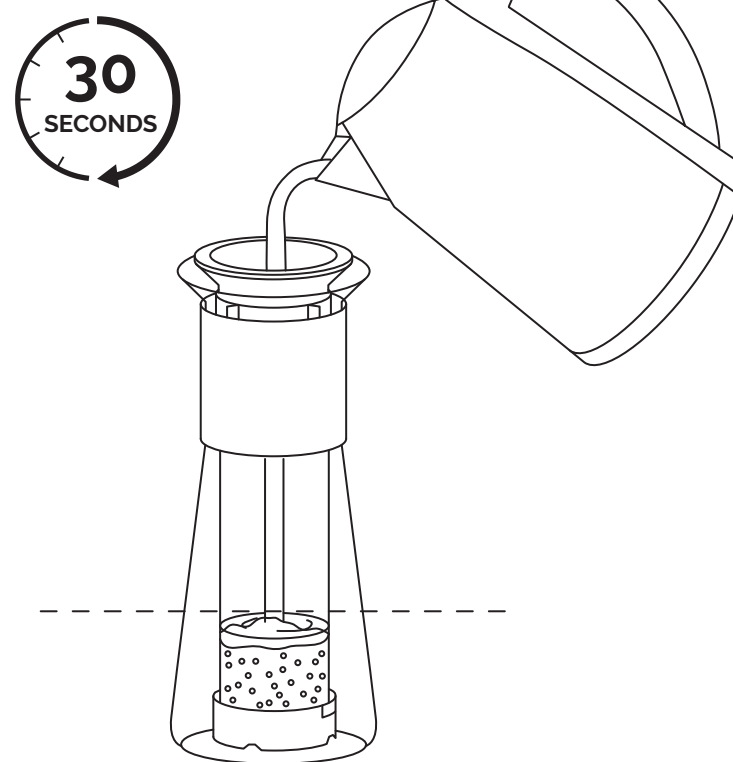
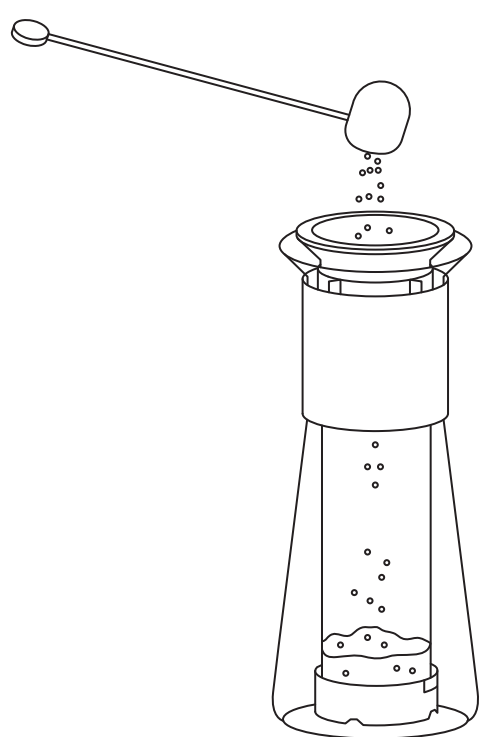

- 4 Stir contents** (water & coffee) using the handle end of the coffee scoop.
- 5 Wait at least 3 minutes** for coffee to brew, or longer depending on strength preference. **Press plunger to bottom** of FLASK until all liquid content is pressed out of the inner chamber.
- 6 Pour & enjoy!** The FLASK design allows you to pour from any direction.

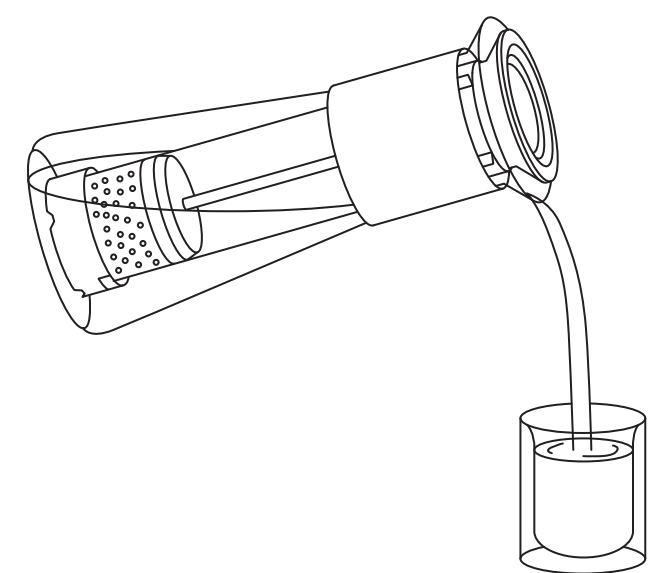
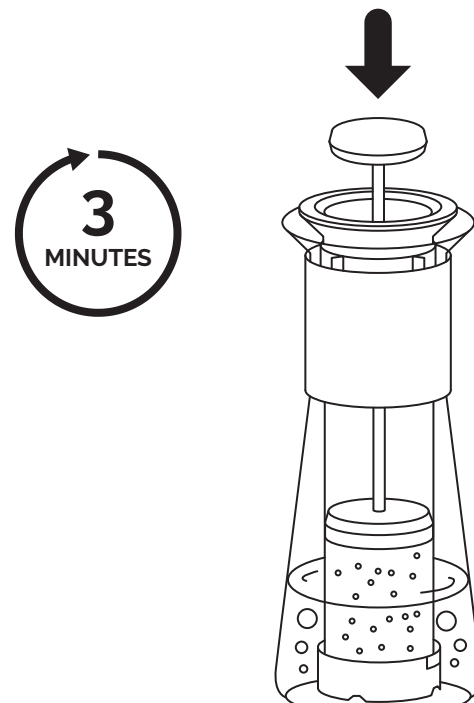
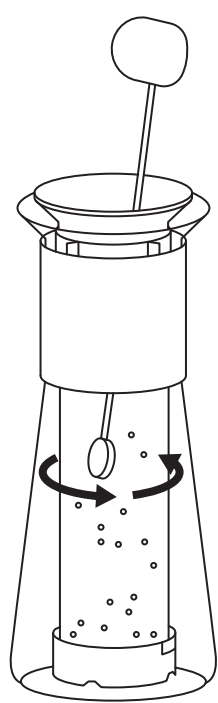

CLEAN UP

IMPORTANT: Allow FLASK to cool off before disassembling

- 1** Once cool, **remove inner brewing chamber.**
- 2** **Take apart the brewing chamber** by unscrewing the base.
- 3** Quickly **press the plunger down** to expel the coffee puck into your compost or trash.
- 4** **Remove leather collar** from FLASK body. **Do NOT wash this part.**
- 5** **Wash FLASK components** with warm water & soap. The FLASK body, brewing chamber, chamber base, metal screen, plunger and stir/scoop are all dishwasher safe.

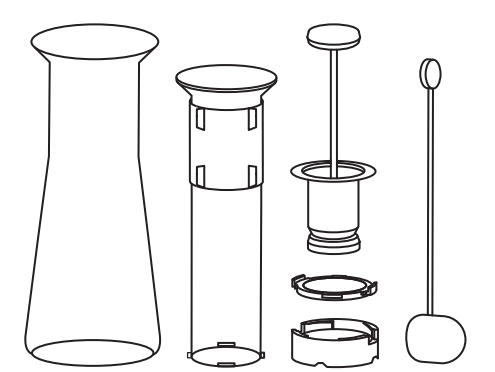
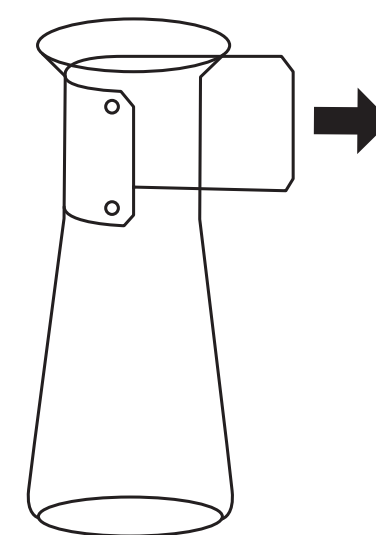
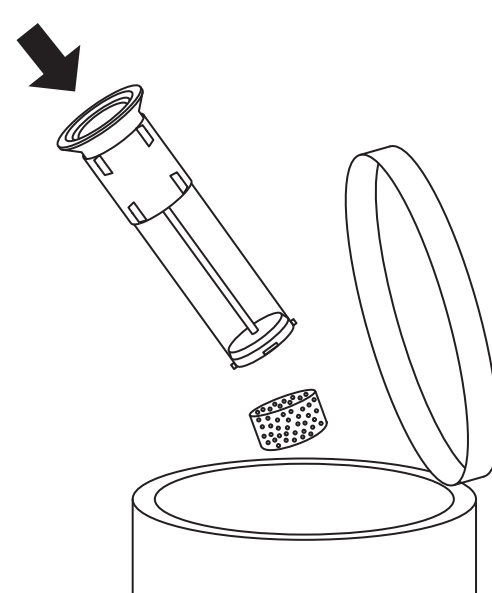
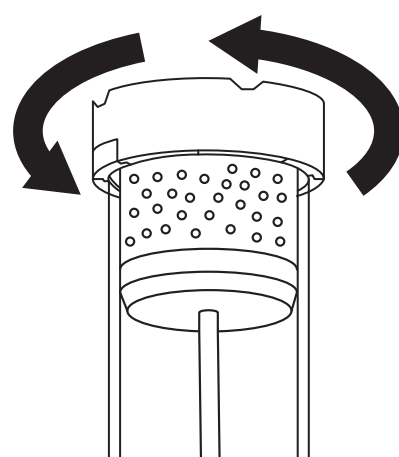
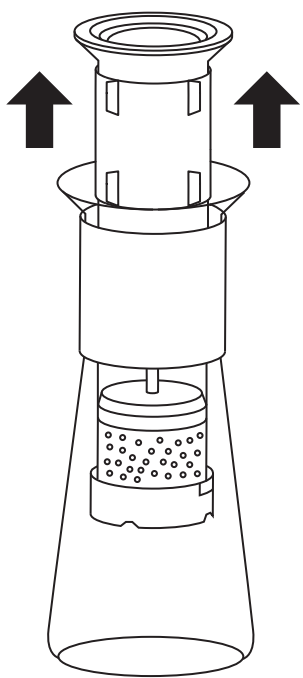

FREQUENTLY ASKED QUESTIONS

HOW COARSE SHOULD THE COFFEE GROUNDS BE?

Grind size will vary based on your preference. Recommended grind is any size from medium to fine. Smaller (espresso) grinds will create more resistance when plunging. (If your grinder has a scale of 1-10, try using a 6-7 grind setting)

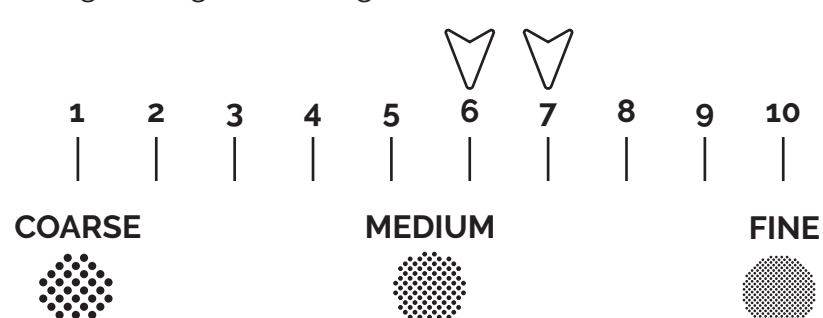

WHAT ARE BENEFITS OF USING THE PAPER FILTER?

This is up to you. The paper filter will filter through more of the oils that are extracted during the process giving a cleaner or lighter flavor. Using only the metal screen filter will give you a darker pour.

Interested in our paper filters? Please visit us at ethoz.us to buy your 365 FLASK Paper Filters box.

IS THIS FLASK BODY TEMPERED GLASS?

Yes, the FLASK is made of completely tempered glass in order to maintain a strong structure and composition.