

*Console
Owner's Manual*

DT3

*Desk Bike
Owner's Manual*

C3-DT

Congratulations on choosing the LifeSpan Workplace™ line of products. These products give you the opportunity to remain productive while taking care of yourself as you integrate movement with normally sedentary tasks.

The average American now spends eleven hours, five days a week, sitting, and burns one-hundred fewer calories each day than they did a few decades ago. Sitting for long periods slows your metabolism, reduces calories burned, and increases your risk for heart disease and diabetes.

Whether you plan on placing this product in a TV room, replace your desk at home or are adding another workspace in the office, LifeSpan Workplace™ products are a great way to add movement to an otherwise sedentary activity.

Before you assemble or operate your product, please read this manual thoroughly. Important information, including safety precautions, ongoing product maintenance, assembly instructions, and information on proper operation are included.

If you need to contact LifeSpan customer service, visit our website at www.LifeSpanFitness.com and select customer service. Complete the information requested and we will respond to your inquiry within one business day. In the United States and Canada you can also call (877) 654-3837 and choose option 4.

Neither LifeSpan Fitness nor its representatives can accept responsibility for any damages or injury incurred as a result of information presented in this manual except under the terms of the product warranty.

Table of Contents

Welcome

Getting Started 6

Warranty

Specifications

Safety

Assembling Your C3-DT Desk Bike 11

Exploded View & Hardware

Assembly Instructions

General Maintenance

Moving

Troubleshooting

Assembly Instructions 22

*Connecting your C3 Desk Bike
to the DT3 console*

Desk Bike Operations 23

Console Overview

Starting the Desk Bike

Innovative Features

Troubleshooting

Personal Settings

Display Details

Warranty

Warranty

Your LifeSpan treadmill/bike desk comes with the following limited warranty valid in North America. If you are outside of this area contact your local authorized LifeSpan dealer.

C3-DT Desk Bike	6 Hr/Day	DT3	
Frame	Lifetime	Parts	2 Years
Parts	2 Years		
Labor	1 Year		

LifeSpan warrants that the equipment it manufactures is free from defects in materials and workmanship under normal use and services. The periods above are based on the date of purchase. During these periods, LifeSpan will repair or replace any defective part. Free labor is included on all parts that are not normally assembled or replaced by the customer within the labor period.

If within the time frames specified above, any part fails to operate properly, login to our website at www.LifeSpanFitness.com, click on "Customer Service" and complete the form to request assistance or call 877.654.3837 option 4 for a Customer Service Agent (please note that certain kinds of service should only be performed by a qualified service technician).

LifeSpan reserves the right to make changes and improvements to our products without incurring any obligations to similarly alter any product purchased. In order to insure our product warranty and to ensure the safe and efficient operation of your LifeSpan product, only authorized parts can be used. The warranty is void if any parts other than those provided by LifeSpan are used.

Exclusions and Limitations:

- This warranty does not apply to any defects caused by negligence, misuse, improper assembly, or maintenance, accident, or "act of God."
- This warranty does not apply to discoloration of paints or plastics.
- LifeSpan shall not be responsible for incidental or consequential damages.
- This warranty is non-transferable from the original owner.

C3-DT Desk Bike

Mechanical and Performance

Seat	Molded, contoured seat
Seat Adjustment	Height - 19 positions
Resistance System	Magnetic - Eddy Current
Pedals	Self balancing
Flywheel Weight	18 lbs (8.1 kg)
Max. User Weight	400 lbs (181.4 kg)
Dimensions	22" W x 28" L (55cm W x 71cm L)
Transport Wheels	Rear Mounted

DT3 Console

Mechanical and Performance

Resistance	16 Levels
Dimensions	12.5" W x 3" D x 2" H 32cm W x 7.6cm D x 5.1cm H

Safety First

When using active workstations, basic precautions should always be followed, including:

- Never drop or insert any object into any opening. If an object falls into an opening, turn the power off and unplug the power cord from the outlet. Remove the object or call customer service at 877.654.3837 option 4.
- Never operate this desk bike if it has been damaged or partially submerged in water.
- To reduce the risk of electric shock, unplug the desk bike from the wall outlet when not in use, before performing any maintenance, or before moving the desk bike.
- Do not use outdoors or in areas of high humidity or extreme temperature changes.
- Do not operate where aerosol spray products are being used or where oxygen is being administered.
- Never place the power cord under carpeting or place any object on top of the cord, this may pinch or damage the cord causing fire damage or personal injury.
- Use this product for its intended use as described in this Owner's Manual. Do not use attachments that are not recommended by LifeSpan.

Children and Pets

- Keep children from playing on your desk bike at all times.
- When in use children and pets should be kept at least 10 feet (3m) away.
- This desk bike can be used by children ages 12 years and above and persons with reduced physical, sensory or lack of experience and knowledge if they have been given supervision or instruction concerning use of the appliance in a safe way and understand the hazards involved.
- Cleaning and user maintenance shall not be made by children without supervision.

Bike Assembly

Assembling Your C3-DT Desk Bike

Exploded View

Prior to starting the assembly process take all of the parts out of the box. Remove plastic bags and lay them out on the floor to become familiar with the components.

Since your desk bike is a heavy piece of equipment it is recommended you use two people during assembly and follow these assembly instructions to reduce any problems that could occur.

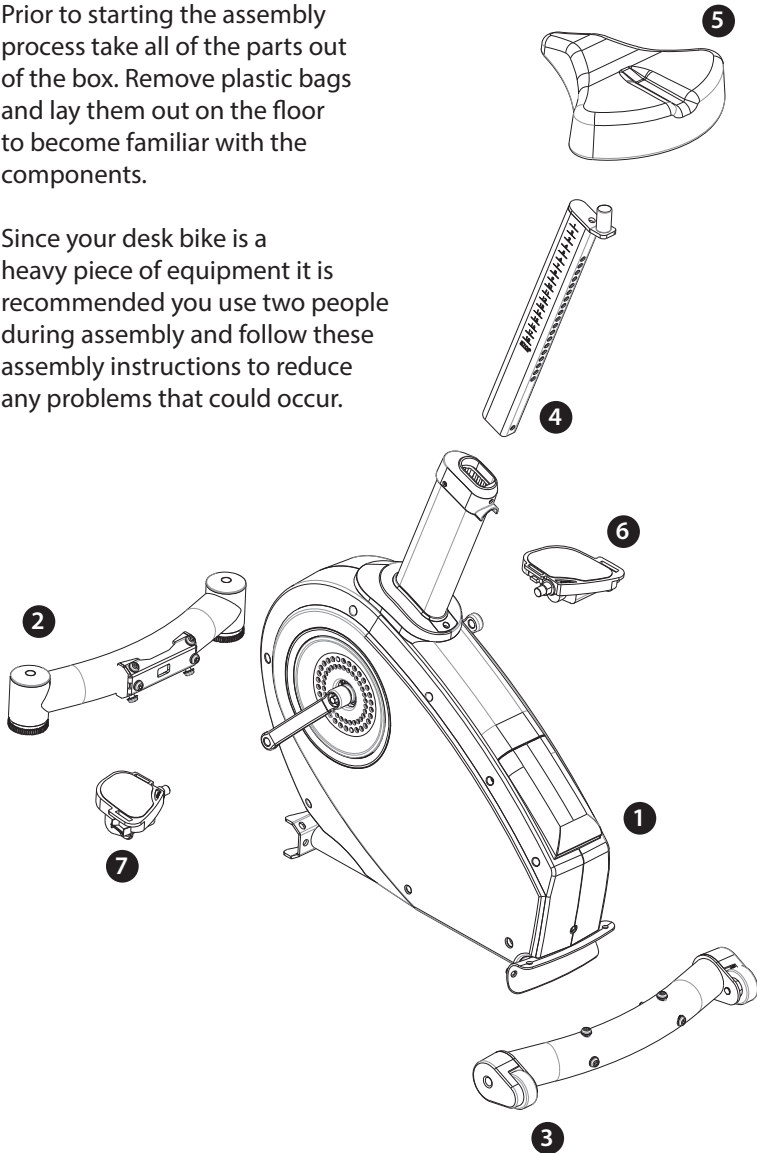

Assembling Your C3-DT Desk Bike

Hardware Included

Item#	Part Description
1	Main Frame
2	Front Support
3	Rear Support
4	Seat Post
5	Seat
6	Right Pedal
7	Left Pedal

Hardware Bag Contents

Item#	Qty.	Part Description
8	2	M8 x 70L Bolt
9	2	M8 Curved Washer
13	1	Multi-Wrench - 10, 13, 14, 15, 17, 22 mm
14	1	Allen Wrench - 5mm

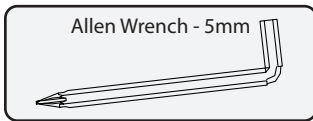
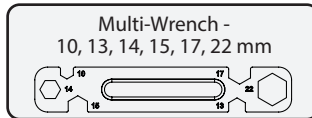
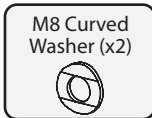
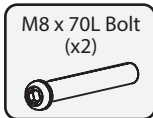

Pre-installed Hardware

Hardware will need to be removed and re-installed during the installation process.

Item#	Qty.	Part Description
10	8	M8 x 16L Bolt
11	6	M8 Washer
9	2	M8 Curved Washer

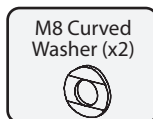
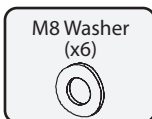
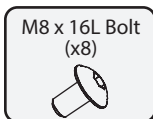

Assembling Your C3-DT Desk Bike

Step 1: Remove Components from Box

- A. Remove plastic bags and lay all parts out on the floor.
- B. Locate the hardware bag.

Step 2: Rear Support Assembly

- A. Place the *Main Frame Assembly (1)* on a solid level surface. It may be necessary to prop the back of the frame up slightly to give clearance for step B.
- B. Align the *Rear Support Assembly (3)* with the *Main Frame Rear Bracket (A)*.
- C. Install two long *M8x70L Bolts (8)* and *Curve Washers (9)*, found in the hardware bag, through the *Rear Support Assembly (3)* and into the *Main Frame Rear Bracket (A)*. **Do not tighten bolts yet.**
- D. Insert two short *M8 Boltsx16L (10)* and *Curved Washers (9)* through the top of the *Main Frame Rear Bracket (A)* and into the *Rear Support Assembly (3)*. **Do not tighten bolts yet.**
- E. Securely tighten the two long *M8x70L Bolts (8)* first, then tighten the two short *M8x16L Bolts (10)*.

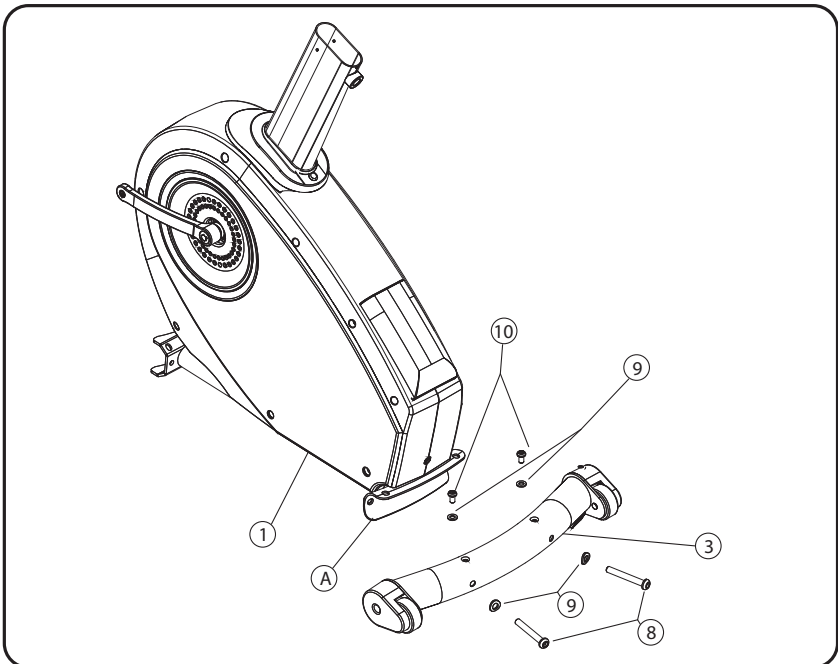

Assembling Your C3-DT Desk Bike

Step 3: Seat Assembly

- A. Pull on the *Seat Post Adjustment Knob (M)* to release the locking pin and slide the *Seat Post (4)* down into the *Seat Post Tube (L)*.
- B. When the desired height is reached, release the *Seat Post Adjustment Knob (M)* to allow the locking pin to engage.

NOTE: In order to complete Step 5 and 6, the seat post needs to be set to the highest level. Pull the *Seat Post* up until the lock pin clicks in the last hole in the *Seat Post*.

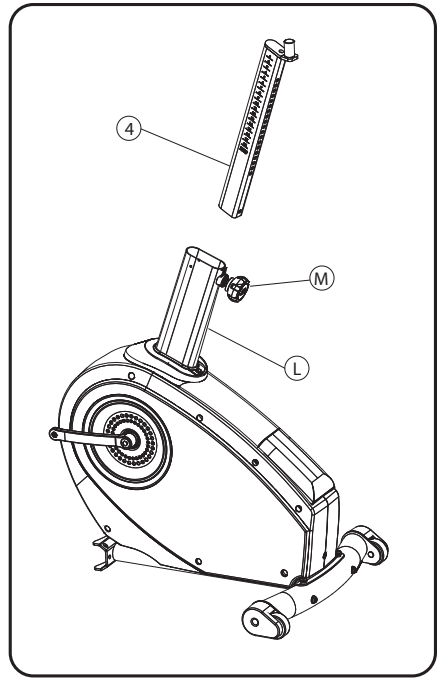

Step 4: Seat Assembly

- A. Place the *Seat (5)* over the *Seat Mount Post (N)*.
- B. Align the *Seat (5)* so the front of the seat is centered and parallel to the floor.
- C. Securely tighten the pre-installed *Nut (12)* on each side of the *Seat Mounting Bracket (O)* under the *Seat (5)*.

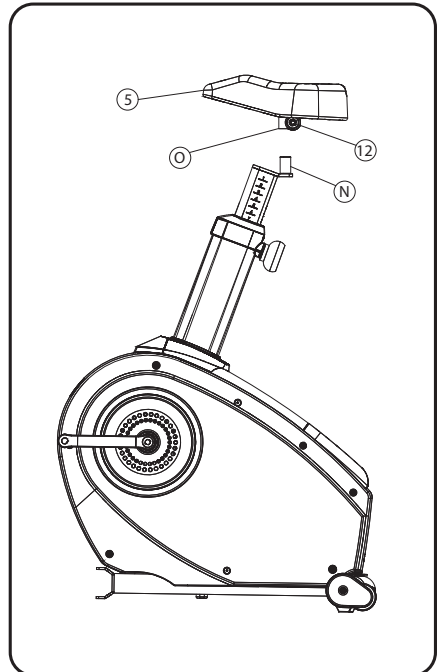

Assembling Your C3-DT Desk Bike

Step 5: Front Support Assembly

- A. Adjust the *Seat Post* so it is at the highest setting.
- B. Tilt the bike back until it is resting on the *Seat* and the *Rear Support Assembly* (as shown below.)
- C. Align the *Front Support Assembly (2)* with the *Front Main Frame Bracket (B)*.
- D. Install two short *M8x16L Bolts (10)* and *Washers (11)* through the top holes of the *Front Main Frame Bracket (B)* and into the *Front Support Assembly (2)*. **Do not tighten bolts yet.**
- E. Install two short *M8x16L Bolts (10)* and *Washers (11)* through the middle holes of the *Front Main Frame Bracket (B)* and into the *Front Support Assembly (2)*. **Do not tighten bolts yet.**
- F. Install two short *M8x16L bolts (10)* and *Washers (11)* through the bottom holes of the *Front Main Frame Bracket (B)* and into the *Front Support Assembly (2)*. **Do not tighten bolts yet.**
- G. Securely tighten the two *M8 Middle Bolts (10)* first, then securely tighten the two *M8 Top Bolts* and two *M8 Bottom Bolts*.

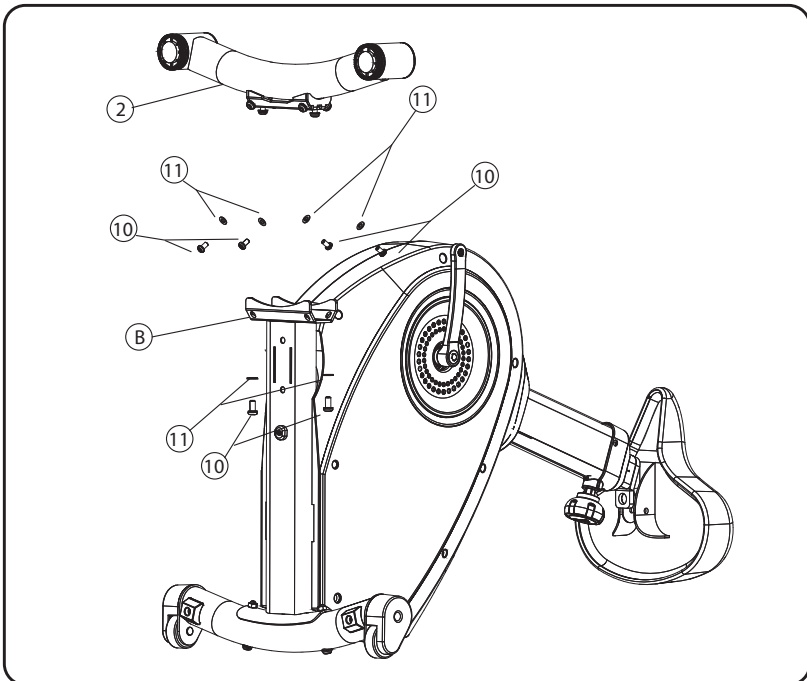

Assembling Your C3-DT Desk Bike

Step 6: Right and Left Pedal Assembly

- A. Identify which pedal goes on the right side and which goes on the left side by locating the "R" on the top of the *Right Pedal* (6) and the "L" on the top of the *Left Pedal* (7).
- B. Hand tighten the *Right Pedal* into the *Right Crank Arm* (R) by turning **clockwise**.
- C. Hand tighten the left pedal into the left crank arm (Q) by turning **counter clockwise**. Be careful not to cross thread the threads.
- D. Tighten both pedals with the provided 15mm Wrench (13).

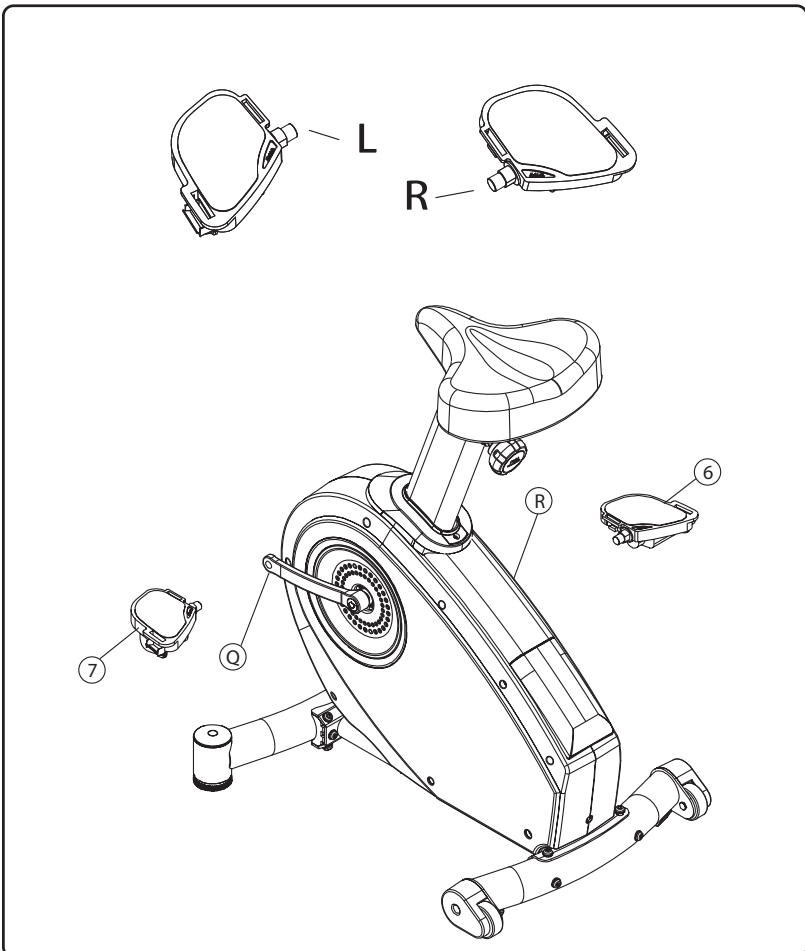

Assembling Your C3-DT Desk Bike

Leveling

Your C3-DT bike comes with two *Leveling Feet (P)* in the front and two *Stationary Feet (Q)* in the rear. Gently rock the bike back and forth to see if any of the feet are not sitting on the floor. Adjust the *Front Feet (P)* until all 4 feet are sitting on the floor.

HINT

If the *Left Rear Foot* is not solid on the floor, turn the *Right Front Foot* **counter-clockwise** to tilt the *Left Rear Foot* down to the floor.

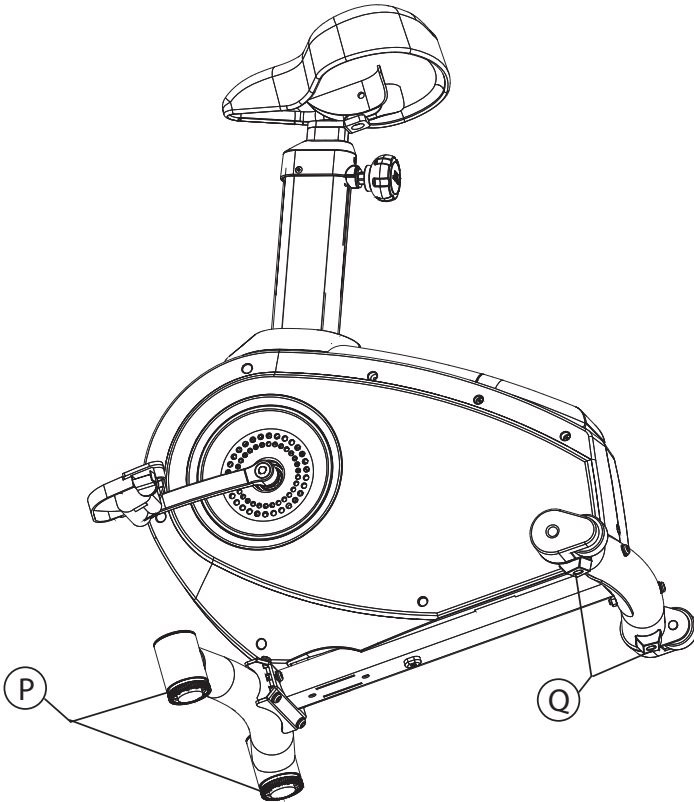

Assembling Your C3-DT Desk Bike

Seat Height Adjustments

Your C3-DT bike allows for 19 positions of height adjustment. To adjust the seat, pull the *Seat Post Adjustment Knob (M)* out and adjust the seat height to the desired position. Once the desired position is reached, release the *Seat Post Adjustment Knob*.

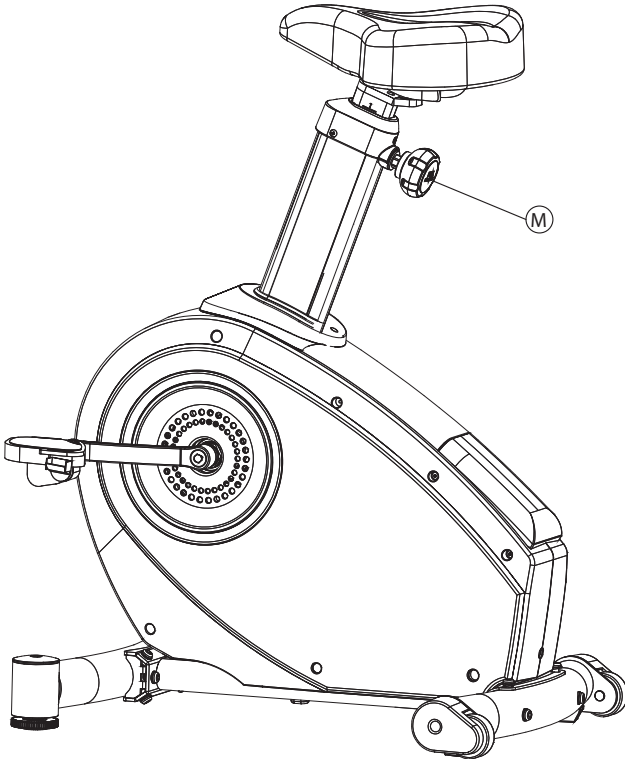

Maintenance and Tips

General Maintenance

1. Keep the desk bike clean and dry. It is a good idea to wipe the desk bike down after each workout.
2. If the unit is not going to be used for any extended period of time it is a good idea to unplug the unit and store in a clean environment.
3. Clean only with mild soap and a slightly damp cloth. Never use solvents when cleaning.

Moving the C3-DT Desk Bike

Your C3-DT desk bike is equipped with two *Transport Wheels (R)* located on the rear support. Move the wire that is coming from the bottom of the frame to the console so it will not get pinched when moving the bike. Carefully tilt the front of the bike up until the Transport Wheels in the back make contact with the floor and roll the bike to the desired location. It may be difficult to roll the bike in plush carpeting.



CAUTION: When lifting, use proper safety precautions and lifting techniques. Bend your knees and elbows, keep your back straight and pull up evenly with both arms.

Troubleshooting

Problem: Unit is unstable or rocks while in use.

Solution: Make sure unit is on a solid, level surface. Adjust the front adjustment feet until all 4 feet are sitting solid on the floor.

Problem: No power at console.

Solution: Try using another outlet or testing something else at the outlet being used to make sure there is power at the outlet. Also check the console wire harness to make sure it has not come loose. If still a problem, contact LifeSpan Customer Service.

Problem: Rough feeling in pedals when in use.

Solution: If everything is tight, contact LifeSpan Customer Service for replacement pedals.

General Maintenance

1. Keep the unit clean and dry. It is a good idea to wipe the unit down after each workout to keep it clean.
2. If the unit is not going to be used for any extended period of time it is a good idea to unplug the unit and store in a clean environment.

Assembly Instructions

After assembling the bike, roll it to the desired location. Plug the console connector into the connector coming from the bottom of the bike. Be sure to screw the two connectors together with the attached thumb screws.

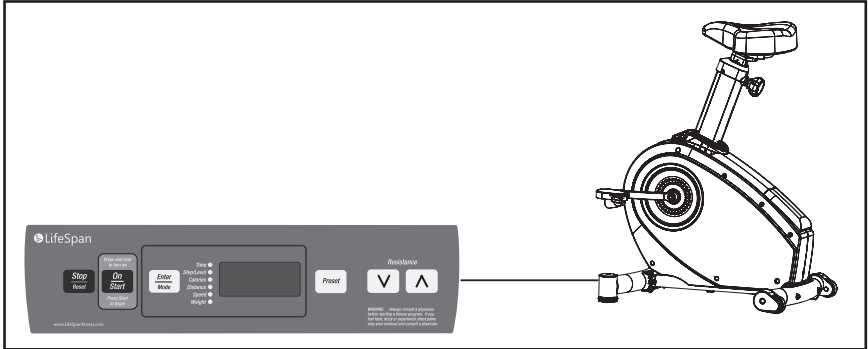

NOTE:

Do not plug the power cord into the equipment until the console is connected.

NOTE:

All desk and DT-3 connectors plug into the bike D-connector the same way.

Safety Key

When using the DT-3 with a bike please use Safety Key (E).

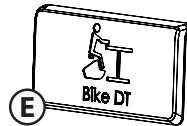

Desk Bike Operations

Desk Bike Console Overview

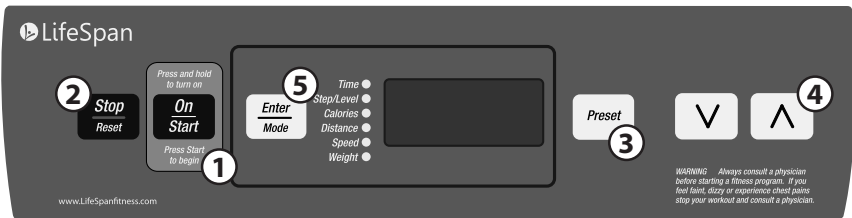

Console Power Buttons

1. **On/Start:** If the console is in sleep mode, press and hold this button for three seconds to turn the console on. Once the console is turned on, press to start the console function.
2. **Stop:** Stops the bike, pausing your use. If pressed for one second, resets the console (all data readouts are reset to zero).
3. **Preset:** When the bike is operating, changes the resistance to Level 1, or to a custom resistance that is set in Settings. See separate section on Preset, as well as the section on Settings.
4. **^ V :** Increases or decreases resistance.
5. **Enter/Mode:** Changes the data readout between Time (the default), Pedal Revolutions, Calories, Distance and Speed. Press and hold for one second to automatically cycle through readouts every five seconds; press again to stop this automatic change.

Starting the Desk Bike

1. Press the On/Start key to turn on the console.
2. The current user weight will be flashing on the display panel. Adjust your weight to obtain accurate calorie calculations.
3. Press Start, and start pedaling. The console will start counting up from 0:00.
4. Press the Up/Down buttons to adjust resistance, or use the Preset key to go directly to your preferred level. See the separate section on Preset, as well as the section on Settings, for more details.

NOTE:

The revolutions are counted normally from 1 to 9,999 revolutions. After 9,999 revolutions, the display format changes to accommodate more than four digits. Take the number shown in the display and add a zero to the right for the correct number of revolutions.

Below are examples of what the display will read and what those numbers mean:

1001 = 10,010 revs

1005 = 10,050 revs

1100 = 11,000 revs

Desk Bike Innovative Features

Personal Settings – there are several features that can be set using our Personal Settings feature to tailor LifeSpan desk bike to your specific preferences. These include:

- **Resume Level:** after pressing pause and returning to the desk bike the default resistance will be 0, which is the normal starting speed. The resume resistance level can be modified to default to return to the previous resistance level.

In addition, the following features are applicable to desk bike users.

- **Audible Safety Beep:** On / Off setting. Each time the control buttons on the console are depressed an audible beep is used as an alert that a change was made. This is designed to prevent accidental speed adjustments being made without users being aware that they may be accidentally depressing a button.
- **Metric versus Standard Readouts:** Change the display readouts for speed and distance between Metric (SI) and English (EN).
- **Charging Port:** This port can be used to charge your wireless mobile devices.

NOTE: You will not be able to save your workout data to a USB via this port; it is used for charging purposes only.

Desk Bike Troubleshooting

This desk bike has been designed and manufactured to be reliable and easy to use. However, if you have a problem, these troubleshooting steps may help you find the cause.

Problem: The console is erratic or not lighting up.

Solution: Check to make sure the bike is properly plugged in. Make sure the console connector is properly plugged into the connector coming the front of the bike.

Problem: "UART" appears in the display.

Solution: Unplug and re-plug the power supply to the bike. Disconnect and reconnect the console connector to the bike. Make sure the thumb screws are properly tightened. Unplug the bike and plug it back in and check to see if it functions properly.

Problem: "dc-6" appears in the display.

Solution: Unplug and re-plug the power supply to the bike. Disconnect and reconnect the console connector to the bike. Make sure the thumb screws are properly tightened. Unplug the bike and plug it back in and check to see if it functions properly. Also make sure the bike is plugged into the wall socket and not into an extension cord or power strip.

Desk Bike Personal Settings

Press and hold "**STOP**" and "**Λ**" for three seconds to enter Settings mode.
F001 should show up on the display.

Press the **Λ** or **∇** arrows to move through the various settings.
Press **Enter** to choose a setting to change.

Press the **Λ** or **∇** arrows to move through the various choices for that setting.

Press **Enter** to select a choice. This takes you back to settings mode, where you can move through the other settings.

Remove and reinstall the safety key.

Personal Setting Options

Units of measure — Choose English for miles (EN) or Metric for kilometers (SI).

Beep — Turns off the normal beep that happens at every keypress.

Level Reset — Controls whether, after a Pause, the bike resumes the most recent resistance level, or resets to 0. If ON, the resistance level resets to 0.

Total Distance — Displays the total distance you have pedaled

Total Hours — Displays the total hours you have pedaled

Display Details

Setting	Setting Displayed	Choice 1 (Default)	Choice 2
Enter Settings mode:	F001	n/a	n/a
UNITS OF MEASURE	F009	EN	SI
BEEP	F010	ON	OFF
LEVEL RESET	F013	0 Resumes at 1	1 Resume to last set level
TOTAL DISTANCE	F011	Press Enter and the total distance you have pedaled will show in display	
TOTAL HOURS	F012	Press Enter and the total hours you have pedaled will show in display	

C3-DT3

Desk Console /Bike

LifeSpan Fitness

P.O. Box 981316

Park City, Utah 84098-1316

Phone: 877.654.3837

www.LifeSpanFitness.com

Version 3.1NB